

63

Letting September 20, 2019

Notice to Bidders, Specifications and Proposal



**Contract No. 61F25
LAKE County
Section 18-00158-13-WR
Route FAU 2665 (Weiland Road)
Project XHE4-442 ()
District 1 Construction Funds**

Prepared by

Checked by

F

(Printed by authority of the State of Illinois)



- 1. TIME AND PLACE OF OPENING BIDS.** Electronic bids are to be submitted to the electronic bidding system (iCX-Integrated Contractors Exchange). All bids must be submitted to the iCX system prior to 10:00 a.m. September 20, 2019 at which time the bids will be publicly opened from the iCX SecureVault.
- 2. DESCRIPTION OF WORK.** The proposed improvement is identified and advertised for bids in the Invitation for Bids as:

**Contract No. 61F25
LAKE County
Section 18-00158-13-WR
Project XHE4-442 ()
Route FAU 2665 (Weiland Road)
District 1 Construction Funds**

Pavement reconstruction and the construction of a HMA pedestrian path next to Weiland Road from Aptakisic Road to Deerfield Parkway, and on Aptakistic Road from Joseph Court to Industrial Drive in the villages of Buffalo Grove and Lincolnshire.

- 3. INSTRUCTIONS TO BIDDERS.** (a) This Notice, the invitation for bids, proposal and letter of award shall, together with all other documents in accordance with Article 101.09 of the Standard Specifications for Road and Bridge Construction, become part of the contract. Bidders are cautioned to read and examine carefully all documents, to make all required inspections, and to inquire or seek explanation of the same prior to submission of a bid.

(b) State law, and, if the work is to be paid wholly or in part with Federal-aid funds, Federal law requires the bidder to make various certifications as a part of the proposal and contract. By execution and submission of the proposal, the bidder makes the certification contained therein. A false or fraudulent certification shall, in addition to all other remedies provided by law, be a breach of contract and may result in termination of the contract.
- 4. AWARD CRITERIA AND REJECTION OF BIDS.** This contract will be awarded to the lowest responsive and responsible bidder considering conformity with the terms and conditions established by the Department in the rules, Invitation for Bids and contract documents. The issuance of plans and proposal forms for bidding based upon a prequalification rating shall not be the sole determinant of responsibility. The Department reserves the right to determine responsibility at the time of award, to reject any or all proposals, to readvertise the proposed improvement, and to waive technicalities.

By Order of the
Illinois Department of Transportation

Omer Osman,
Acting Secretary

INDEX
FOR
SUPPLEMENTAL SPECIFICATIONS
AND RECURRING SPECIAL PROVISIONS

Adopted January 1, 2019

This index contains a listing of SUPPLEMENTAL SPECIFICATIONS, frequently used RECURRING SPECIAL PROVISIONS, and LOCAL ROADS AND STREETS RECURRING SPECIAL PROVISIONS.

ERRATA Standard Specifications for Road and Bridge Construction (Adopted 4-1-16) (Revised 1-1-19)

SUPPLEMENTAL SPECIFICATIONS

<u>Std. Spec. Sec.</u>	<u>Page No.</u>
106 Control of Materials	1
107 Legal Regulations and Responsibility to Public	2
403 Bituminous Surface Treatment (Class A-1, A-2, A-3)	3
404 Micro-Surfacing and Slurry Sealing	4
405 Cape Seal	15
406 Hot-Mix Asphalt Binder and Surface Course	25
420 Portland Cement Concrete Pavement	26
424 Portland Cement Concrete Sidewalk	28
442 Pavement Patching	29
502 Excavation for Structures	30
503 Concrete Structures	32
504 Precast Concrete Structures	35
542 Pipe Culverts	36
586 Sand Backfill for Vaulted Abutments	37
602 Catch Basin, Manhole, Inlet, Drainage Structure, and Valve Vault Construction, Adjustment, and Reconstruction	39
630 Steel Plate Beam Guardrail	40
631 Traffic Barrier Terminals	43
670 Engineer's Field Office and Laboratory	44
701 Work Zone Traffic Control and Protection	45
704 Temporary Concrete Barrier	46
780 Pavement Striping	48
781 Raised Reflective Pavement Markers	49
888 Pedestrian Push-Button.....	50
1001 Cement	51
1003 Fine Aggregates	52
1004 Coarse Aggregates	53
1006 Metals	56
1020 Portland Cement Concrete	58
1043 Adjusting Rings	60
1050 Poured Joint Sealers	62
1069 Pole and Tower	64
1077 Post and Foundation	65
1096 Pavement Markers	66
1101 General Equipment	67
1102 Hot-Mix Asphalt Equipment	68
1103 Portland Cement Concrete Equipment	70
1105 Pavement Marking Equipment	72
1106 Work Zone Traffic Control Devices	74

RECURRING SPECIAL PROVISIONS

The following RECURRING SPECIAL PROVISIONS indicated by an "X" are applicable to this contract and are included by reference:

<u>CHECK SHEET #</u>			<u>PAGE NO.</u>
1	X	Additional State Requirements for Federal-Aid Construction Contracts	75
2	X	Subletting of Contracts (Federal-Aid Contracts)	78
3	X	EEO	79
4		Specific EEO Responsibilities Non Federal-Aid Contracts	89
5		Required Provisions - State Contracts	94
6		Asbestos Bearing Pad Removal	100
7		Asbestos Waterproofing Membrane and Asbestos HMA Surface Removal	101
8		Temporary Stream Crossings and In-Stream Work Pads	102
9		Construction Layout Stakes Except for Bridges	103
10	X	Construction Layout Stakes	106
11		Use of Geotextile Fabric for Railroad Crossing	109
12		Subsealing of Concrete Pavements	111
13		Hot-Mix Asphalt Surface Correction	115
14		Pavement and Shoulder Resurfacing	117
15		Patching with Hot-Mix Asphalt Overlay Removal	118
16		Polymer Concrete	120
17		PVC Pipeliner	122
18		Bicycle Racks	123
19		Temporary Portable Bridge Traffic Signals	125
20		Work Zone Public Information Signs	127
21	X	Nighttime Inspection of Roadway Lighting	128
22		English Substitution of Metric Bolts	129
23		Calcium Chloride Accelerator for Portland Cement Concrete	130
24		Quality Control of Concrete Mixtures at the Plant	131
25	X	Quality Control/Quality Assurance of Concrete Mixtures	139
26		Digital Terrain Modeling for Earthwork Calculations	155
27		Reserved	157
28		Preventive Maintenance – Bituminous Surface Treatment (A-1)	158
29		Reserved	164
30		Reserved	165
31		Reserved	166
32		Temporary Raised Pavement Markers	167
33		Restoring Bridge Approach Pavements Using High-Density Foam	168
34		Portland Cement Concrete Inlay or Overlay	171
35		Portland Cement Concrete Partial Depth Hot-Mix Asphalt Patching	175

LOCAL ROADS AND STREETS RECURRING SPECIAL PROVISIONS

The following LOCAL ROADS AND STREETS RECURRING SPECIAL PROVISIONS indicated by an "X" are applicable to this contract and are included by reference:

<u>CHECK SHEET #</u>		<u>PAGE NO.</u>
LRS1	Reserved	179
LRS2	Furnished Excavation	180
LRS3	X Work Zone Traffic Control Surveillance	181
LRS4	Flaggers in Work Zones	182
LRS5	Contract Claims	183
LRS6	Bidding Requirements and Conditions for Contract Proposals	184
LRS7	Bidding Requirements and Conditions for Material Proposals	190
LRS8	Reserved	196
LRS9	Bituminous Surface Treatments	197
LRS10	Reserved	198
LRS11	Employment Practices	199
LRS12	Wages of Employees on Public Works	201
LRS13	Selection of Labor	203
LRS14	Paving Brick and Concrete Paver Pavements and Sidewalks	204
LRS15	Partial Payments	207
LRS16	Protests on Local Lettings	208
LRS17	Substance Abuse Prevention Program	209
LRS18	Multigrade Cold Mix Asphalt	210

<u>TOPIC</u>	<u>INDEX</u>	<u>PAGE</u>
Special Provisions		
LOCATION OF IMPROVEMENT		1
DESCRIPTION OF IMPROVEMENT		1
AVAILABLE REPORTS		2
CLEARING AND REMOVALS		3
CONCRETE WASHOUT FACILITY		3
COOPERATION WITH ADJACENT CONTRACTS		4
DEWATERING		4
DRIVEWAYS AND ENTRANCES		5
ENVIRONMENTAL PERMITTING AGENCIES		6
LANDSCAPING MOBILIZATION		6
OPENING OF SECTION OF HIGHWAY TO TRAFFIC		7
POTABLE WATER		7
PUBLIC CONVENIENCE AND SAFETY		7
PROTECTION AND RESTORATION OF PROPERTY		9
SIGNING		9
STORMWATER TREATMENT: DEWATERING/TREATMENT DITCHES		10
SURVEY CONTROL POINTS		14
TEMPORARY TOILETS		15
Special Provisions for Pay Items		
ADJUSTING WATER MAIN		16
AGGREGATE BASE COURSE, TYPE B		17
AGGREGATE FOR TEMPORARY ACCESS		18
AGGREGATE SHOULDERS, TYPE B		18
ANTI-GRAFFITI PROTECTION SYSTEM		19
BASE FOR TELESCOPING SIGN SUPPORT, SPECIAL		21
BLOCKWALL RECONSTRUCT		22
CATCH BASIN, MANHOLE, INLET, DRAINAGE STRUCTURE, AND VALVE VAULT CONSTRUCTION, ADJUSTMENT, AND RECONSTRUCTION		22
CHAIN LINK FENCE, 4' (SPECIAL); CHAIN LINK GATES (SPECIAL)		23
COMBINATION CURB AND GUTTER		24
COMBINATION CURB AND GUTTER REMOVAL		24
CONCRETE STEPS		25
DETECTABLE WARNINGS		25
DOCUMENTATION CAMERAS		26
DRAINAGE STRUCTURES TO BE CLEANED; CLEANING DRAINAGE SYSTEM		29
DRY RUBBLE STONE OR BROKEN CONCRETE TREE WELLS		30
DUST CONTROL, SPECIAL		31
EARTH EXCAVATION		32
ENGINEER'S FIELD OFFICE, TYPE A (MODIFIED)		33

EXPLORATION TRENCH, SPECIAL	34
FENCE REMOVAL	34
FIRE HYDRANTS TO BE ADJUSTED	34
FIRE HYDRANTS TO BE MOVED (SPECIAL)	35
FIRE HYDRANTS TO BE RELOCATED	36
FIRE HYDRANT WITH AUXILIARY VALVE AND VALVE BOX	37
FLOCCULATION LOGS; FLOCCULATION POWDER	38
FORM LINER TEXTURED SURFACE	40
FRAMES AND GRATES, TYPE 11V	43
FURNISHED EXCAVATION	44
GRATING FOR CONCRETE FLARED END SECTION	44
INLET FILTERS	45
INLETS, SPECIAL	45
JOINT TIES FOR CONCRETE PIPE	46
MECHANICALLY STABILIZED EARTH RETAINING WALL	47
ORNAMENTAL FENCE	47
PAINT PAVEMENT MARKING – RAISED MEDIAN	50
PERENNIAL PLANTS, ORNAMENTAL TYPE, GALLON POT; PERENNIAL PLANTS, ORNAMENTAL TYPE, 3-GALLON POT; PERENNIAL PLANTS, BULB TYPE	51
PERIMETER EROSION BARRIER	51
PIPE DRAINS	55
PIPE UNDERDRAINS, TYPE 1, 4”	56
POROUS GRANULAR EMBANKMENT, SPECIAL	56
PRECONSTRUCTION VIDEO TAPING	57
PROTECTIVE COAT	57
RECESSED REFLECTIVE PAVEMENT MARKER	58
RECESSED REFLECTIVE PAVEMENT MARKER REMOVAL	59
REMOVAL AND DISPOSAL OF REGULATED SUBSTANCES	59
REMOVAL OF DRAINAGE STRUCTURES	71
REMOVAL OF EXISTING PAVEMENT AND APPURTENANCES	72
REMOVING EXISTING SEPTIC TANK	73
SANITARY MANHOLES TO BE ADJUSTED; SANITARY MANHOLES TO BE REMOVED	73
STAINING CONCRETE STRUCTURES	73
STORM SEWER	75
STORM SEWER REMOVAL AND INSTALLATION	76
STORM SEWERS, CLASS B, 8”	77
STORM SEWERS, WATER MAIN QUALITY PIPE	78
SURVEY MONUMENTS	79
TEMPORARY DITCH CHECKS	80
TEMPORARY DITCH CHECKS (SPECIAL)	81
TEMPORARY HEAVY DUTY EROSION CONTROL BLANKET	82
TEMPORARY PAVEMENT (VARIABLE DEPTH)	83
TEMPORARY SIDEWALK	83

TOPSOIL FURNISH AND PLACE.....	84
TREE PROTECTION AND PRESERVATION	85
TREE REMOVAL.....	87
TREE ROOT PRUNING.....	88

IDOT District One Specifications

AGGREGATE SUBGRADE IMPROVEMENT (D-1)	89
AGGREGATE SURFACE COURSE FOR TEMPORARY ACCESS (D-1).....	92
COARSE AGGREGATE FOR BACKFILL, TRENCH BACKFILL AND BEDDING (D-1).....	94
EMBANKMENT I (D-1).....	95
FRICTION AGGREGATE (D-1).....	97
GROUND TIRE RUBBER (GTR) MODIFIED ASPHALT BINDER (D-1).....	100
HMA MIXTURE DESIGN REQUIREMENTS (D-1).....	102
MAINTENANCE OF ROADWAYS (D-1)	109
RECLAIMED ASPHALT PAVEMENT AND RECLAIMED ASPHALT SHINGLES (D-1).....	110
STATUS OF UTILITIES (D-1).....	121
TEMPORARY INFORMATION SIGNING (D-1).....	145
TEMPORARY PAVEMENT (D-1)	147
WINTERIZED TEMPORARY ACCESS (D-1)	148

LCDOT Traffic Control Special Provisions

TRAFFIC CONTROL PLAN (L.C.-T- SECTION 700).....	150
TRAFFIC CONTROL AND PROTECTION (SPECIAL) (L.C.-T- SECTION 700)....	152

Traffic Signal Special Provisions

LAKE COUNTY DOT TRAFFIC SIGNAL GENERAL REQUIREMENTS	162
OPTIMIZE TRAFFIC SIGNAL SYSTEM.....	178
SERVICE INSTALLATION (TRAFFIC SIGNALS).....	182
GROUNDING OF TRAFFIC SIGNAL SYSTEMS	186
COILABLE NON-METALLIC CONDUIT.....	188
UNDERGROUND RACEWAYS	189
HANDHOLES	190
FIBER OPTIC TRACER CABLE.....	192
RAILROAD, FULL-ACTUATED CONTROLLER AND CABINET.....	193
UNINTERRUPTABLE POWER SUPPLY, SPECIAL.....	196
EMERGENCY VEHICLE PRIORITY SYSTEM LINE SENSOR CABLE, NO. 20 3/C	200
RAILROAD INTERCONNECT CABLE	201
TRAFFIC SIGNAL POST.....	202
LIGHT EMITTING DIODE (LED) SIGNAL HEAD AND OPTICALLY PROGRAMMED LED SIGNAL HEAD	203
FLASHING BEACON INSTALLATION, RELOCATION AND REMOVAL	207
LIGHT EMITTING DIODE (LED) PEDESTRIAN SIGNAL HEAD	209
TRAFFIC SIGNAL BACKPLATE.....	212

DETECTOR LOOP	213
RADAR VEHICLE DETECTION SYSTEM	215
EMERGENCY VEHICLE PRIORITY SYSTEM	217
PEDESTRIAN PUSH-BUTTON	218
TEMPORARY TRAFFIC SIGNAL INSTALLATION.....	220
TEMPORARY TRAFFIC SIGNAL TIMING	227
REBUILD EXISTING HANDHOLE.....	228
RELOCATE EXISTING PEDESTRIAN PUSH-BUTTON	229
LAYER II (DATALINK) SWITCH (LCDOT).....	230
REMOTE CONTROLLED VIDEO SYSTEM (LCDOT)	231
VIDEO DETECTION SYSTEM COMPLETE INTERSECTION (LCDOT).....	233
RELOCATE EXISTING REMOTE-CONTROLLED VIDEO SYSTEM (LCDOT)....	235
RELOCATE SWITCH (LCDOT)	236
LAYER III (NETWORK) SWITCH (LCDOT)	237
RELOCATE EXISTING ENCODER (LCDOT)	238
MAINTENANCE OF EXISTING TRAFFIC SIGNAL INSTALLATION (LCDOT) .	239
FULL-ACTUATED CONTROLLER AND TYPE IV CABINET, SPECIAL (LCDOT)	
.....	242
FIBER OPTIC CABLE (LCDOT).....	245
ELECTRIC CABLE (LCDOT)	248
OUTDOOR RATED NETWORK CABLE (LCDOT)	249
TRAFFIC SIGNAL POST (SPECIAL) (LCDOT).....	250
STEEL MAST ARM ASSEMBLY AND POLE (SPECIAL) (LCDOT)	252
STEEL COMBINATION MAST ARM ASSEMBLY AND POLE (SPECIAL) (LCDOT)	
.....	252
CONCRETE FOUNDATION (LCDOT).....	255
LED INTERNALLY ILLUMINATED STREET NAME SIGN (LCDOT)	257
REMOVE EXISTING TRAFFIC SIGNAL EQUIPMENT (LCDOT)	259
RELOCATE EXISTING ITS CONTROLLER CABINET	260
RELOCATE EXISTING ADAPTIVE CONTROL SYSTEM.....	261

Lighting Special Provisions

GENERAL ELECTRICAL REQUIREMENTS.....	263
ELECTRIC SERVICE INSTALLATION.....	278
ELECTRIC UTILITY SERVICE CONNECTION (COMED).....	279
UNDERGROUND RACEWAYS	280
UNIT DUCT	281
WIRE AND CABLE.....	283
MAINTENANCE OF LIGHTING SYSTEMS	285
LUMINAIRE INSTALLATION	289
LUMINAIRE (SPECIAL)	296
LIGHT POLE, WEATHERING STEEL, 35 FT. M.H., 6 FT MAST ARM.....	297
LIGHT POLE, SPECIAL	299
LIGHT POLE, SPECIAL, TYPE 2	300
BASE COVER, LIGHT POLE.....	302

BREAKAWAY DEVICE, COUPLING.....	303
LIGHT POLE FOUNDATION, OFFSET	304
REMOVAL OF LIGHTING UNIT, SALVAGE	305
TEMPORARY LIGHTING CONTROLLER	306
TEMPORARY WOOD POLE	307
TEMPORARY LUMINAIRE	308
TEMPORARY ELECTRIC SERVICE INSTALLATION	313
TEMPORARY MAST ARM, ALUMINUM, 15 FT.....	314
Local Roads Special Provisions.....	315
LR 107-4	
Environmental Survey Request Forms.....	316
Borrow/Waste/Use Areas (BDE 2289)	
Storm Water Pollution Prevention Plan.....	318
Storm Water Pollution Prevention Plan (BDE 2342)	
Soils Map	
Erosion Control Inspection Report (BC2259)	
IL 532 2104 Notice of Intent (NOI)	
Permits.....	335
LCSMC Watershed Development Permit	
USACE Permit	
WCL/CN Requirements for Work Near Railroad.....	344
Railroad Right of Entry (ROE)	
ROE Application	
Railroad Agreement Special Provision Relative to Flagging	
Soils.....	356
LPC-663 Uncontaminated Soil Certification	
CCDD Preapproval Letter	

BDE SPECIAL PROVISIONS

The following special provisions indicated by an "X" are applicable to this contract. An * indicates a new or revised special provision for the letting.

<u>File Name</u>	<u>Pg.</u>	<u>Special Provision Title</u>	<u>Effective</u>	<u>Revised</u>
80099		Accessible Pedestrian Signals (APS)	April 1, 2003	Jan. 1, 2014
80274		Aggregate Subgrade Improvement	April 1, 2012	April 1, 2016
80192		Automated Flagger Assistance Device	Jan. 1, 2008	
80173	372	X Bituminous Materials Cost Adjustments	Nov. 2, 2006	Aug. 1, 2017
80241		Bridge Demolition Debris	July 1, 2009	
50261	374	X Building Removal-Case I (Non-Friable and Friable Asbestos)	Sept. 1, 1990	April 1, 2010
50481		Building Removal-Case II (Non-Friable Asbestos)	Sept. 1, 1990	April 1, 2010
50491		Building Removal-Case III (Friable Asbestos)	Sept. 1, 1990	April 1, 2010
50531		Building Removal-Case IV (No Asbestos)	Sept. 1, 1990	April 1, 2010
80404		Coarse Aggregate Quality for Micro-Surfacing and Cape Seals	Jan. 1, 2019	
80384	394	X Compensable Delay Costs	June 2, 2017	April 1, 2019
80198		Completion Date (via calendar days)	April 1, 2008	
80199		Completion Date (via calendar days) Plus Working Days	April 1, 2008	
80293		Concrete Box Culverts with Skews > 30 Degrees and Design Fills ≤ 5 Feet	April 1, 2012	July 1, 2016
80311		Concrete End Sections for Pipe Culverts	Jan. 1, 2013	April 1, 2016
80277		Concrete Mix Design – Department Provided	Jan. 1, 2012	April 1, 2016
80261	398	X Construction Air Quality – Diesel Retrofit	June 1, 2010	Nov. 1, 2014
80387		Contrast Preformed Plastic Pavement Marking	Nov. 1, 2017	
80029	401	X Disadvantaged Business Enterprise Participation	Sept. 1, 2000	Mar. 2, 2019
80402	411	X Disposal Fees	Nov. 1, 2018	
80378		Dowel Bar Inserter	Jan. 1, 2017	Jan. 1, 2018
80405		Elastomeric Bearings	Jan. 1, 2019	
* 80415	413	X Emulsified Asphalts	Aug. 1, 2019	
80388	416	X Equipment Parking and Storage	Nov. 1, 2017	
80229	417	X Fuel Cost Adjustment	April 1, 2009	Aug. 1, 2017
80304	420	X Grooving for Recessed Pavement Markings	Nov. 1, 2012	Nov. 1, 2017
80246	423	X Hot-Mix Asphalt – Density Testing of Longitudinal Joints	Jan. 1, 2010	Aug. 1, 2018
80398	425	X Hot-Mix Asphalt – Longitudinal Joint Sealant	Aug. 1, 2018	Jan. 1, 2019
80406		Hot-Mix Asphalt – Mixture Design Verification and Production (Modified for I-FIT Projects)	Jan. 1, 2019	
80399	429	X Hot-Mix Asphalt – Oscillatory Roller	Aug. 1, 2018	Nov. 1, 2018
80347		Hot-Mix Asphalt – Pay for Performance Using Percent Within Limits – Jobsite Sampling	Nov. 1, 2014	Aug. 1, 2018
80383		Hot-Mix Asphalt – Quality Control for Performance	April 1, 2017	Jan. 1, 2019
80392	431	X Lights on Barricades	Jan. 1, 2018	
80336		Longitudinal Joint and Crack Patching	April 1, 2014	April 1, 2016
80411		Luminaires, LED	April 1, 2019	
80393	433	X Manholes, Valve Vaults, and Flat Slab Tops	Jan. 1, 2018	Mar. 1, 2019
80400	435	X Mast Arm Assembly and Pole	Aug. 1, 2018	
80045		Material Transfer Device	June 15, 1999	Aug. 1, 2014
80394		Metal Flared End Section for Pipe Culverts	Jan. 1, 2018	April 1, 2018
80165		Moisture Cured Urethane Paint System	Nov. 1, 2006	Jan. 1, 2010
* 80412		Obstruction Warning Luminaires, LED	Aug. 1, 2019	
80349	436	X Pavement Marking Blackout Tape	Nov. 1, 2014	April 1, 2016
80371	438	X Pavement Marking Removal	July 1, 2016	
80390	439	X Payments to Subcontractors	Nov. 2, 2017	
80389	440	X Portland Cement Concrete	Nov. 1, 2017	
80359		Portland Cement Concrete Bridge Deck Curing	April 1, 2015	Nov. 1, 2017

<u>File Name</u>	<u>Pg.</u>	<u>Special Provision Title</u>	<u>Effective</u>	<u>Revised</u>
80300		Preformed Plastic Pavement Marking Type D - Inlaid	April 1, 2012	April 1, 2016
80328	441	X Progress Payments	Nov. 2, 2013	
34261		Railroad Protective Liability Insurance	Dec. 1, 1986	Jan. 1, 2006
80157	442	X Railroad Protective Liability Insurance (5 and 10)	Jan. 1, 2006	
80306		Reclaimed Asphalt Pavement (RAP) and Reclaimed Asphalt Shingles (RAS)	Nov. 1, 2012	Jan. 1, 2019
80407		Removal and Disposal of Regulated Substances	Jan. 1, 2019	
80395		Sloped Metal End Section for Pipe Culverts	Jan. 1, 2018	
80340		Speed Display Trailer	April 2, 2014	Jan. 1, 2017
80127		Steel Cost Adjustment	April 2, 2014	Aug. 1, 2017
80408		Steel Plate Beam Guardrail Manufacturing	Jan. 1, 2019	
* 80413		Structural Timber	Aug. 1, 2019	
80397	444	X Subcontractor and DBE Payment Reporting	April 2, 2018	
80391	445	X Subcontractor Mobilization Payments	Nov. 2, 2017	April 1, 2019
* 80317		Surface Testing of Hot-Mix Asphalt Overlays	Jan. 1, 2013	Aug. 1, 2019
80298	446	X Temporary Pavement Marking	April 1, 2012	April 1, 2017
20338		Training Special Provision	Oct. 15, 1975	
80403		Traffic Barrier Terminal, Type 1 Special	Nov. 1, 2018	
80409	449	X Traffic Control Devices – Cones	Jan. 1, 2019	
80410		Traffic Spotters	Jan. 1, 2019	
80318		Traversable Pipe Grate for Concrete End Sections	Jan. 1, 2013	Jan. 1, 2018
80288	450	X Warm Mix Asphalt	Jan. 1, 2012	April 1, 2016
80302	452	X Weekly DBE Trucking Reports	June 2, 2012	April 2, 2015
* 80414		Wood Fence Sight Screen	Aug. 1, 2019	
80071	453	X Working Days	Jan. 1, 2002	

The following special provisions are in the 2019 Supplemental Specifications and Recurring Special Provisions.

<u>File Name</u>	<u>Special Provision Title</u>	<u>New Location(s)</u>	<u>Effective</u>	<u>Revised</u>
80382	Adjusting Frames and Grates	Articles 602.02(s) and (t), 1043.04, and 1043.05	April 1, 2017	
80366	Butt Joints	Article 406.08(c)	July 1, 2016	
80386	Calcium Aluminate Cement for Class PP-5 Concrete Patching	Article 1001.01(e)	Nov. 1, 2017	
80396	Class A and B Patching	Articles 442.06(a)(1) and (2)	Jan. 1, 2018	Nov. 1, 2018
80377	Portable Changeable Message Signs	Articles 701.20(h) and 1106.02(i)	Nov. 1, 2016	April 1, 2017
80385	Portland Cement Concrete Sidewalk	Article 424.12	Aug. 1, 2017	

The following special provision has been deleted from use.

<u>File Name</u>	<u>Special Provision Title</u>	<u>Effective</u>	<u>Revised</u>
80376	Hot-Mix Asphalt – Tack	Nov. 1, 2016	
80401	Portland Cement Concrete Pavement Connector for Bridge Approach Slab	Aug. 1, 2018	

GUIDE BRIDGE SPECIAL PROVISION INDEX/CHECK SHEET

Effective as of the: April 26, 2019 Letting

Pg #	√	File Name	Title	Effective	Revised
		GBSP 4	Polymer Modified Portland Cement Mortar	June 7, 1994	Apr 1, 2016
		GBSP 12	Drainage System	June 10, 1994	Jun 24, 2015
		GBSP 13	High-Load Multi-Rotational Bearings	Oct 13, 1988	Apr 1, 2016
		GBSP 14	Jack and Remove Existing Bearings	April 20, 1994	April 13, 2018
		GBSP 15	Three Sided Precast Concrete Structure	July 12, 1994	Dec 21, 2016
		GBSP 16	Jacking Existing Superstructure	Jan 11, 1993	April 13, 2018
		GBSP 17	Bonded Preformed Joint Seal	July 12, 1994	Jan 1, 2007
		GBSP 18	Modular Expansion Joint	May 19, 1994	Dec 29, 2014
		GBSP 21	Cleaning and Painting Contact Surface Areas of Existing Steel Structures	June 30, 2003	April 13, 2018
		GBSP 25	Cleaning and Painting Existing Steel Structures	Oct 2, 2001	Apr 22, 2016
		GBSP 26	Containment and Disposal of Lead Paint Cleaning Residues	Oct 2, 2001	Apr 22, 2016
		GBSP 28	Deck Slab Repair	May 15, 1995	April 13, 2018
		GBSP 29	Bridge Deck Microsilica Concrete Overlay	May 15, 1995	March 1, 2019
		GBSP 30	Bridge Deck Latex Concrete Overlay	May 15, 1995	Oct 20, 2017
		GBSP 31	Bridge Deck High-Reactivity Metakaolin (HRM) Conc Overlay	Jan 21, 2000	March 1, 2019
		GBSP 33	Pedestrian Truss Superstructure	Jan 13, 1998	Dec 29, 2014
		GBSP 34	Concrete Wearing Surface	June 23, 1994	Oct 4, 2016
		GBSP 35	Silicone Bridge Joint Sealer	Aug 1, 1995	Oct 15, 2011
		GBSP 45	Bridge Deck Thin Polymer Overlay	May 7, 1997	Feb 6, 2013
454	X	GBSP 51	Pipe Underdrain for Structures	May 17, 2000	Jan 22, 2010
		GBSP 53	Structural Repair of Concrete	Mar 15, 2006	Apr 1, 2016
		GBSP 55	Erection of Curved Steel Structures	June 1, 2007	
		GBSP 56	Setting Piles in Rock	Nov 14, 1996	Apr 1, 2016
		GBSP 59	Diamond Grinding and Surface Testing Bridge Sections	Dec 6, 2004	Mar 29, 2017
		GBSP 60	Containment and Disposal of Non-Lead Paint Cleaning Residues	Nov 25, 2004	Apr 22, 2016
		GBSP 61	Slipform Parapet	June 1, 2007	March 1, 2019
		GBSP 67	Structural Assessment Reports for Contractor's Means and Methods	Mar 6, 2009	Oct 5, 2015
		GBSP 71	Aggregate Column Ground Improvement	Jan 15, 2009	Oct 15, 2011
		GBSP 72	Bridge Deck Fly Ash or GGBF Slag Concrete Overlay	Jan 18, 2011	March 1, 2019
		GBSP 75	Bond Breaker for Prestressed Concrete Bulb-T Beams	April 19, 2012	
		GBSP 77	Weep Hole Drains for Abutments, Wingwalls, Retaining Walls And Culverts	April 19, 2012	Oct 22, 2013
		GBSP 78	Bridge Deck Construction	Oct 22, 2013	Dec 21, 2016
		GBSP 79	Bridge Deck Grooving (Longitudinal)	Dec 29, 2014	Mar 29, 2017
		GBSP 81	Membrane Waterproofing for Buried Structures	Oct 4, 2016	March 1, 2019
		GBSP 82	Metallizing of Structural Steel	Oct 4, 2016	Oct 20, 2017
		GBSP 83	Hot Dip Galvanizing for Structural Steel	Oct 4, 2016	Oct 20, 2017
		GBSP 85	Micropiles	Apr 19, 1996	Oct 5, 2015
		GBSP 86	Drilled Shafts	Oct 5, 2015	Oct 4, 2016
		GBSP 87	Lightweight Cellular Concrete Fill	Nov 11, 2011	Apr 1, 2016
		GBSP 88	Corrugated Structural Plate Structures	Apr 22, 2016	April 13, 2018
		GBSP 89	Preformed Pavement Joint Seal	Oct 4, 2016	March 1, 2019
		GBSP 90	Three Sided Precast Concrete Structure (Special)	Dec 21, 2016	April 13, 2018
		GBSP 91	Crosshole Sonic Logging Testing of Drilled Shafts	Apr 20, 2016	
		GBSP 92	Thermal Integrity Profile Testing of Drilled Shafts	Apr 20, 2016	

Pg #	√	File Name	Title	Effective	Revised
		GBSP 93	Preformed Bridge Joint Seal	Dec 21, 2016	March 1, 2019
		GBSP 94	Warranty for Cleaning and Painting Steel Structures	Mar 3, 2000	Nov 24, 2004
		GBSP 95	Bituminous Coated Aggregate Slopewall	Mar 21, 1997	Mar 19, 2018

LIST ANY ADDITIONAL SPECIAL PROVISIONS BELOW

The following Guide Bridge Special Provisions have been incorporated into the 2016 Standard Specifications:

File Name	Title	Std Spec Location
GBSP32	Temporary Sheet Piling	522
GBSP38	Mechanically Stabilized Earth Retaining Walls	522
GBSP42	Drilled Soldier Pile Retaining Wall	522
GBSP43	Driven Soldier Pile Retaining Wall	522
GBSP44	Temporary Soil Retention System	522
GBSP46	Geotextile Retaining Walls	522
GBSP57	Temporary Mechanically Stabilized Earth Retaining Walls	522
GBSP62	Concrete Deck Beams	504
GBSP64	Segmental Concrete Block Wall	522
GBSP65	Precast Modular Retaining Wall	522
GBSP73	Cofferdams	2017 Supp
GBSP74	Permanent Steel Sheet Piling (LRFD)	522
GBSP76	Granular Backfill for Structures	2017 Supp
GBSP80	Fabric Reinforced Elastomeric	1028
GBSP84	Precast, Prestressed Concrete Beams	2017 Supp

The following Guide Bridge Special Provisions have been discontinued or have been superseded:

File Name	Title	Disposition:
GBSP70	Braced Excavation	Use TSRS per Sec 522
GBSP95	Bridge Deck Concrete Sealer	Use July 1, 2012 version for Repair projects only

STATE OF ILLINOIS **SPECIAL PROVISIONS**

The following Special Provisions supplement the specifications listed in the table below, which apply to and govern the proposed improvement designated as FAU Route 2665 (Weiland Road) Aptakistic Road to Deerfield Parkway, Section Number 18-00158-13-WR, Project Number XHE4(442), Job Number C-91-229-18 in Lake County and in case of conflict with any part or parts of said specifications, the said Special Provisions shall take precedence and govern.

SPECIFICATION	ADOPTED/DATED
Standard Specifications for Road and Bridge Construction	April 1, 2016
Manual on Uniform Traffic Control Devices for Streets and Highways Illinois Supplement	Latest Edition
Supplemental Specifications, Recurring Special Provisions, and BDE Special Provisions (indicated on sheets included herein)	January 2019
Standard Specifications for Water & Sewer main Construction in Illinois	Latest Edition
Manual of Test Procedures for Materials	Latest Edition

Contract No. 61F25

LOCATION OF IMPROVEMENT

This improvement is located at Weiland Road from Aptakistic Road to Deerfield Parkway and at Aptakistic Road from Joseph Court to Industrial Drive, in Sections 21, 27 and 28 of Vernon Township, in Villages of Buffalo Grove and Lincolnshire, Lake County, Illinois. The total gross and net length of the improvement is 6,602.8 feet (1.25 miles).

DESCRIPTION OF IMPROVEMENT

The work consists of pavement reconstruction, PCC sidewalks, HMA bike paths, retaining walls, storm sewers, earth excavation, erosion control, landscaping, tree removal, proposed trees, signal and lighting improvements, as well as all incidental and collateral work necessary to complete the project as shown on the plans and described herein.

AVAILABLE REPORTS

No project specific reports were prepared

When applicable, the following checked reports and record information is available for Bidders' reference upon request:

- Record structural plans
- Preliminary Site Investigation (PSI)
- Preliminary Environmental Site Assessment (PESA)
- Soils/Geotechnical Report
- Boring Logs
- Pavement Cores
- Location Drainage Study (LDS)
- Hydraulic Report
- Noise Analysis
- Other: IEPA LPC-663 Uncontaminated Soil Certification

Those seeking these reports should request access from:

Thomas P. Somodji
Project Manager
Lake County Division of Transportation
600 W. Winchester Road
Libertyville, IL 60048
(847) 377-7485
TSomodji@lakecountyil.gov

or they can be downloaded at

<https://civiltechftp.exavault.com/share/view/18e2y-6sjc15d8>

CLEARING AND REMOVALS

The contractor shall pay special attention to article 201.01(a) of the standard specifications. Removal of all obstructions in the right-of-way, that are not included in a specific removal item, shall be considered clearing and will not be measured for payment. This shall include, but not limited to walls, foundations, buildings, accumulations of rubbish of whatever nature, old Type III barricades, old water heaters, old corrugated metal pipe, rubber tires, concrete blocks, utility anchors, metal parts, abandoned wooden power poles, gates, and all vegetation, trees, shrubs, etc. less than 6" in diameter.

The Contractor is prohibited from burning any material within or adjacent to the project limits. All excess or waste material shall be hauled away from the project site by the Contractor and legally disposed of outside the right-of-way. No extra compensation will be allowed the Contractor for any expense incurred by complying with the requirements of this note.

CONCRETE WASHOUT FACILITY

Description. The Contractor shall take sufficient precautions to prevent pollution of streams, lakes, reservoirs, and wetlands with fuels, oils, bitumens, calcium chloride, or other harmful materials according to Article 107.23 of the "Standard Specifications".

General. To prevent pollution by residual concrete and/or the byproduct of washing out the concrete trucks, concrete washout facilities shall be constructed and maintained. The concrete washout shall be constructed, maintained, and removed according to this special provision and details included in these plans. Concrete washout facilities shall be required regardless of the need for NPDES permitting. On projects requiring NPDES permitting, concrete washout facilities shall also be addressed in the Storm Water Pollution Prevention Plan.

The concrete washout facility shall be constructed on the job site according to details included in these plans. The Contractor may elect to use a pre-fabricated portable concrete washout structure. The Contractor shall submit a plan for the concrete washout facility, to the Engineer for approval, a minimum of 10 calendar days before the first concrete pour. The working concrete washout facility shall be in place before any delivery of concrete to the site. The Contractor shall limit all concrete washout activities to the designated area.

The concrete washout facility shall be located no closer than 50 feet from any environmentally sensitive areas, such as water bodies, wetlands, and/or other areas indicated on the plans. Adequate signage shall be placed at the washout facility and elsewhere as necessary to clearly indicate the location of the concrete washout facility to the operators of concrete trucks.

The concrete washout facility shall be adequately sized to fully contain the concrete washout needs of the project. The contents of the concrete washout facility shall not exceed 75% of the facility capacity. Once the 75% capacity is reached, concrete placement shall be discontinued until the facility is cleaned out. Hardened concrete shall be removed and properly disposed of

outside the right-of-way. Slurry shall be allowed to evaporate, or shall be removed and properly disposed of outside the right-of-way. The Contractor shall immediately replace damaged basin liners or other washout facility components to prevent leakage of concrete waste from the washout facility. Concrete washout facilities shall be inspected by the Contractor after each use. Any and all spills shall be reported to the Engineer and cleaned up immediately. The Contractor shall remove the concrete washout facility when it is no longer needed.

Basis of Payment. The cost of all materials required and all labor necessary to comply with the above will not be paid for separately, but shall be considered as included in the cost of MOBILIZATION, and no additional compensation will be allowed.

COOPERATION WITH ADJACENT CONTRACTS

The Contractor is informed that the Department is aware of adjacent contracts that are currently scheduled during the same time period as this contract.

CONTRACT NO. 61E24 – WEILAND ROAD (DEERFIELD PARKWAY TO LAKE COOK ROAD) under the lead agency of Lake County Division of Transportation

Contact Information:

Thomas P. Somodji

Project Manager

Lake County Division of Transportation

600 W. Winchester Road

Libertyville, IL 60048

(847) 377-7485

TSomodji@lakecountyil.gov

The Contractor is required to cooperate with these adjacent contracts in accordance with Section 105.08 of the Standard Specifications and may be required to modify his/her staging operations in order to meet these requirements.

DEWATERING

Description. This work shall consist of providing labor, tools, equipment, and materials necessary for dewatering (regardless of the water source) work areas to relatively dry conditions as determined by the Engineer and maintain suitable working conditions and sediment control so that the improvements are constructed in the dry.

Materials. The Contractor shall be solely responsible for the choice of products and equipment; for the design, installation, and operation; as well as "means and methods" of performing the work; and subsequent removal of dewatering systems and their safety and conformity with local codes, regulations and these Specifications. All products, equipment and "means and methods"

selected shall be adequate for the intended use/application. Review by Engineer does not relieve Contractor from compliance with the requirements specified herein.

Contractor shall submit to Engineer for review a description of dewatering techniques and equipment to be used, together with detail drawings showing lengths of discharge piping and points of discharge including erosion control procedures.

Methods. The Contractor shall select the pumps he/she desires to use and the rate at which the pumps discharge, but adequate protection at the pump discharge shall be provided by the Contractor, subject to review by the Engineer. The Contractor shall ensure that downstream water quality shall not be impaired which includes but not limited to collection and disposal of sediment and floatables. Contingency quantities for erosion control mat, flocculation logs and flocculation powder have been provided which Contractor can use in conjunction with other dewatering or sediment collection means to remove sediment from water discharge.

At all times during the excavation period and until completion and acceptance of work at Final Inspection, ample means and equipment shall be provided with which to remove promptly and dispose of properly all water (including ground water, river water, storm sewer water and storm runoff) entering any excavation or any other parts of the work.

Water pumped or drained from the work required for this Contract shall be disposed of in a safe and suitable manner without damage to the nearby bodies of water, adjacent property or streets or to other work under construction. Water shall not be discharged without adequate protection of the surface at the point of discharge. All water from dewatering operations shall be filtered by using filter bags or another alternative measure approved by the County. All filter bags must have secondary containment devices and should be placed on level ground. Water from dewatering operations must have sediment removed before being allowed to return to the original lake, creek, and/or ditch. The discharge shall be designed so that the returning waters do not cause erosion. No water shall be discharged into sanitary sewers. No water shall be discharged into storm sewers. Any and all damages caused by dewatering the work shall be promptly repaired by the Contractor. The Contractor is responsible for providing any and all labor, materials and equipment needed for DEWATERING in order to meet the scheduled completion of the project.

Basis of Payment. The cost of all materials required and all labor necessary to comply with the above will not be paid for separately, but shall be considered as included in the cost of MOBILIZATION, and no additional compensation will be allowed.

DRIVEWAYS AND ENTRANCES

Existing HMA driveways shall be saw cut at the limits of construction line. The surface shall be removed to the saw cut. The aggregate base shall be appropriately prepared, and the driveway shall be resurfaced with 3 inches of Hot-Mix Asphalt Surface Course, Mix "D", N50 unless otherwise specified in the plans or by the Engineer.

Existing P.C. Concrete driveways shall be saw cut at the limits of construction line. The driveway shall be reconstructed to the same width with 6 inches (PE) or 8 inches (CE) of Aggregate Base Course, Type B and 8 inches of P.C. Concrete unless otherwise specified in the plans or by the Engineer.

ENVIRONMENTAL PERMITTING AGENCIES

This project requires a US Army Corps of Engineers (USACE) 404 permit that has been secured by Lake County. As a condition of this permit the Contractor shall submit an in-stream work plan to the USACE and Lake County Stormwater Management Commission (LCSMC) for approval. If requested by the Lake County Division of Transportation or LCSMC, a meeting shall be held with the LCSMC to discuss construction and stormwater management. Guidelines on acceptable in-stream work techniques can be found on the USACE website. The cost of all materials and labor necessary to comply with the above provisions to prepare and implement an in-stream work plan will not be paid for separately, but shall be considered as included in the cost of “MOBILIZATION”.

Add the following paragraph to Article 105.03 of the “Standard Specifications”

- (e) Permitting Agency Deduction: Any monetary payment required from a permitting agency related to improper erosion and sediment control may be passed along to the Contractor as a deduction from future pay estimates. Monetary payments will include fees and violations attributable to the Contractor’s actions or inaction resulting in improper erosion and sediment control. The deduction will be applied to monies due or that might become due to the Contractor. Permitting agencies include the Lake County Stormwater Management Commission, the Illinois Environmental Protection Agency, the Army Corps of Engineers, and other regulatory agencies.

LANDSCAPING MOBILIZATION

More than one mobilization for tree removal and landscaping may be required for this project. The first tree mobilization will remove trees as identified on the proposed plans and subsequent mobilizations will remove trees impacted by the installation of the utilities and work behind the back of curb. The first mobilization for landscaping will be required to place permanent landscaping on the east side of the roadway at the end of Construction Stage I at the direction of the Engineer, and the subsequent mobilization will be required to place remaining permanent landscaping. No additional compensation will be allowed for the additional mobilizations.

OPENING OF SECTION OF HIGHWAY TO TRAFFIC

Work under construction shall be opened to traffic according to Article 107.29 of the “Standard Specifications” and the following:

The Contractor shall work expeditiously to open traffic lanes closed due to roadwork. The Engineer shall be the sole judge of when a lane is ready to be opened to traffic. The opening of a lane to traffic shall be in accordance to Section 107.29 of the “Standard Specifications”.

Roadwork requiring a closure of a lane, which has been opened previously to traffic, will be allowed at the discretion of the Engineer and under the following conditions:

1. The lane closure shall only be in effect while workers are present in or near the closed lane.
2. The closed lane will be reopened to traffic at the end of the workday.
3. All traffic control devices pertaining to the lane closure shall be removed from the roadway at the end of the workday.

POTABLE WATER

Should the Contractor desire to obtain water for construction purposes from the local area, the Contractor will be responsible for making arrangements through the Local Agency. The Local Agency will instruct the Contractor where a potable water supply from a hydrant near the work site is located. The Agency shall meter the potable water used by the Contractor and the Contractor will be charged for the water used at the Agency rates. The Contractor is responsible for the transportation of the water to the site where needed. The cost of all materials required and all labor necessary to comply with the above provisions will not be paid for separately, but shall be considered as included in the cost of "MOBILIZATION".

PUBLIC CONVENIENCE AND SAFETY

The Contractor shall limit public inconveniences and safety conflicts according to Article 107.09 of the “Standard Specifications” and the following:

Keeping Roads Open to Traffic: For this project the Contractor shall maintain traffic according to the Maintenance of Traffic Plan shown on the plans. The Contractor shall limit flagging operations affecting the open lanes i.e. flagging for vehicles entering or leaving the construction site etc..., to the following times:

<i>Monday - Friday</i>	<i>9:00 am</i>	<i>to</i>	<i>3:00 pm</i>
------------------------	----------------	-----------	----------------

At all other times, including periods of no construction activity, the Contractor shall maintain the available traffic lanes.

If local and/or area conditions warrant the above times may be adjusted (i.e. lengthened or shortened) by the Engineer. To request a change the Contractor shall submit to the Engineer a plan including the revised start and end time a minimum of 48 hours prior to the proposed revision. The Engineer will notify the Contractor 24 hours in advance with an approval or disapproval.

If the Contractor fails to provide a plan and/or the Contractor disregards the decision by of the Engineer the Traffic Control Deficiency Charge will be applied as stated in the Special Provisions for Traffic Control and Protection.

Safety and Convenience: The Contractor shall maintain entrances along the proposed improvement. Interference with traffic movements and inconvenience to owners of abutting property and the public shall be kept to a minimum. Any delays or inconveniences caused by the Contractor, by complying with these requirements shall be considered as included in the unit bid prices of the contract and no additional compensation will be allowed.

Contractors shall plan their work so that there will be no open holes in the pavement and that all barricades will be removed from the roadway during non-working hours, except where required for public safety.

Steel road plates may be used as temporary cover over excavations. Anytime steel road plates are in the roadway these requirements apply:

- The steel road plate shall sit flat on the pavement and be free of defects and warping
- It shall be shimmed with a non-asphaltic material to prevent vertical movement
- If the steel road plate is not under constant surveillance, it shall be pinned to prevent horizontal movement by a minimum of 6 pins; 4 pins predrilled into the corners of the plates and 1 pin predrilled into each side parallel to the trench. Pins shall be drilled 3 inches into the pavement and not protrude above the pavement surface
- The steel road plate shall be at least 1 inch thick and large enough to allow a minimum of 1 foot of bearing on each side of the trench
- A one foot wide HMA surface course ramp shall be placed around the perimeter of the plate
- Multiple steel road plates shall be tack welded together to prevent separation if they are not under constant surveillance
- Appropriate advanced warning signs (W8-24 “STEEL PLATE AHEAD” and W8-1 “BUMP”) are required

Steel road plates may be left in place overnight, in emergency situations and with the concurrence of the Engineer. Steel road plates left in place overnight shall be attached to the roadway by a minimum of 6 pins; 4 pins predrilled into the corners of the plates and 1 pin

predrilled into each side parallel to the trench. Pins shall be drilled 3 inches into the pavement and not protrude above the pavement surface.

Steel road plates left in-place for more than 72 hours, shall also be:

- Recessed into the street surface the thickness of the steel road plate with no difference in elevation with the existing surface
- Secured in-place to prevent horizontal movement with HMA surface course between the existing pavement vertical edge and the steel road plate

Road plates shall not be used from November 15th to April 15th without approval from the Engineer.

Property Access: The Contractor shall provide access to abutting property at all times during the construction, except for periods of short interruption. The Contractor shall notify the Property Owner no less than 24 hours in advance of the short interruption of access and/or services and shall notify the Owner of the time and duration of the interruption. The cost to provide access shall be paid for and included in the items for Temporary Access.

PROTECTION AND RESTORATION OF PROPERTY

The Contractor shall protect and restore property according to Article 107.20 of the “Standard Specifications” and the following:

Trees and Shrubs: Extra care shall be exercised when operating equipment around trees or shrubs. Injured branches or roots shall be pruned in a manner satisfactory to the Engineer and shall be painted where the cut was made. Roots exposed during excavating operations shall be neatly pruned and covered with topsoil. This work shall be done as soon as possible and shall be considered as included in the cost of the contract, and no additional compensation will be allowed.

SIGNING

The Contractor will be required to relocate or remove and replace signs which interfere with his construction operations, and to temporarily reset all such signs during construction operations. This work will be included in the unit bid prices of the Contract's Traffic Control items.

Any signs which are damaged beyond repair during construction operations shall be replaced in kind by the Contractor to the satisfaction of the Engineer at no additional cost to the contract.

STORMWATER TREATMENT: DEWATERING/TREATMENT DITCHES

The Floc Logs are designed for use in flowing conditions for treating turbid water to remove suspended sediment. Stormwater Treatment Ditches are used to introduce site-specific polymers to turbid waters in such a manner to facilitate mixing and reaction between the polymer and the suspended particles. Collection of the flocculated particulate that forms will greatly reduce turbidity in stormwater.

A ditch is created, either by digging out the bed or building up the walls, and lined with plastic or geosynthetic fabric to prevent erosion. Floc Logs are secured along the ditch, allowing the water to mix with the site-specific polymer blend and begin reacting with the suspended sediment. Checks can be placed along the ditch, forcing the water to flow over and around them, to increase turbulence and mixing with the Floc Logs. The ditch is lined with jute or similar matting to provide surface area for the flocculated sediment to adhere to and help remove fine particulate from the water.

- i. This application can be used for dewatering applications, recirculation treatment, or continuous flow treatment systems.
- ii. Cover the exposed soil with jute matting and apply Silt Stop powder to prevent erosion. With highly erosive soils protection with geotextile or plastic sheeting may be necessary.
- iii. Ensure only turbid water is entering the ditch. The turbidity of the water flowing through the system should not exceed 4% solids. If the sediment load of the water is above this limit, a grit pit or settling tank may need to be installed to encourage primary settling before treatment.
- iv. Make sure that the logs are not resting in mud or buried by sediment; drive rebar or wooden "feet" into the logs to raise them slightly if needed.
- v. Logs should be placed in a series, one after another. The number of logs is determined by the flow rate of the water and the length of the mixing ditch is determined by the reaction time required for the polymer.
- vi. Particle collection can be accomplished using jute matting in the ditch, as outlined here, or by using another method of particle collection as outlined in the next section.

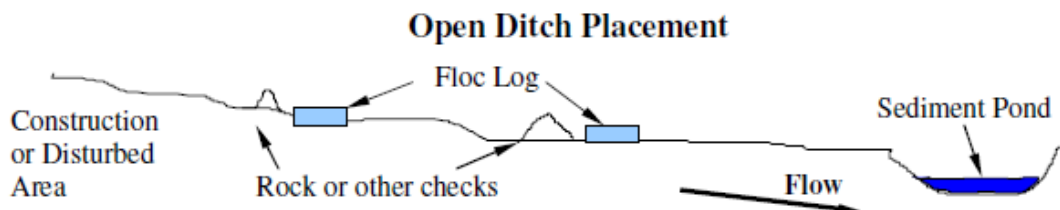

Polymer Enhanced BMP Application Guide

Step-by-Step Dewatering / Treatment Ditch

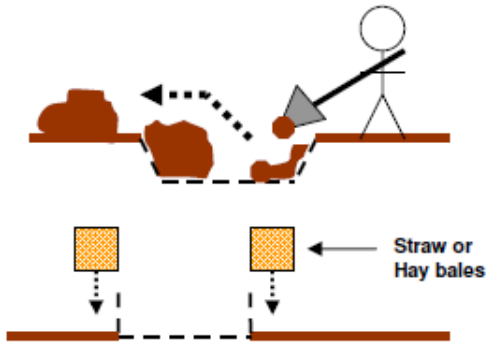

Step 1: Create ditch.

The ditch can be dug into the ground, or created by building up the walls.

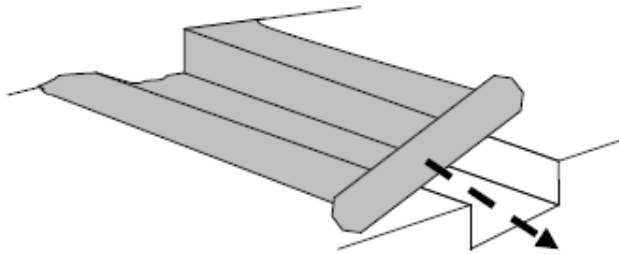

Step 2: Line with Plastic.

The plastic sheeting is used to prevent the water being treated from picking up sediment and causing erosion.

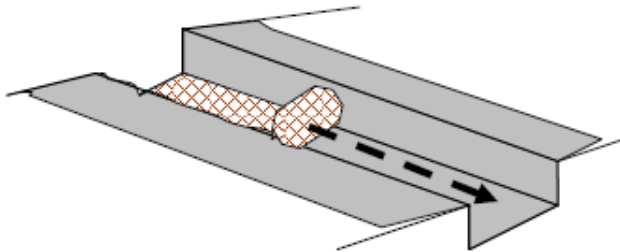

Step 3: Lay Jute Matting.

The jute matting provides a surface for the particulate formed during treatment to adhere onto.

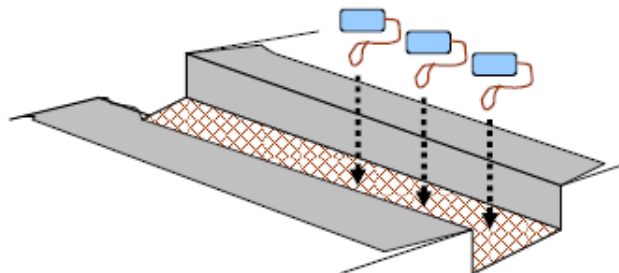

Step 4: Place Floc Logs.

The Floc Logs are positioned in a line at the top of the ditch, allowing the water to flow over and around them.

Polymer Enhanced BMP Application Guide

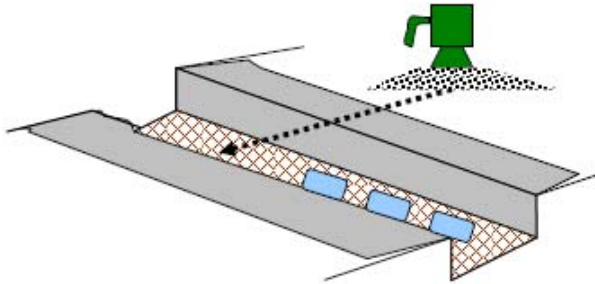

Step 5: Apply Silt Stop powder.

Sprinkling the correct site-specific Silt Stop powder over the jute matting in the bottom portion of the ditch will assist in final water clarification.



Here is the water being pumped into the treatment ditch. Note the light brown color and turbidity.



The clarified water as it is leaving the site can be discharged directly to riparian waters.

Polymer Enhanced BMP Application Guide

**Application Example: Treatment Ditch
Dewatering Operation**

1) Dig ditch



2) Line with plastic



3) Lay jute matting



4) Place Floc Logs (upstream end)



5) Apply Silt Stop (downstream end)



6) Ready for pumping



SURVEY CONTROL POINTS

The Contractor shall furnish the Engineer with the materials required to establish survey control points according to Article 105.09 of the “Standard Specifications” and the following:

Paint: The Contractor shall furnish, at their expense, white, pink or purple pavement marking paint in aerosol cans, for use by the Engineer. The paint shall last up to 6 months; be non-freezing, be functional to 14°F; and be fully operational in an inverted position.

The Contractor and subcontractors shall only use white, pink or purple colors for their own markings. At no time will the Contractor use any of the J.U.L.I.E. utility colors listed in Article 107.31 of the “Standard Specifications”.

Hubs: The Contractor shall furnish, at their expense, hubs for use by the Engineer according to the following:

1. Shall be 1 3/8” x 7/8” x 18” (actual dimension).
2. Shall be furnished in securely banded (on each end) bundles of 25 pieces.
3. The material shall be kiln dried Douglas fir, oak or maple and surfaced on the 2 larger sides and without splits, pitch pockets, wane, knots or decayed wood.
4. The tapered end on each hub shall be pencil point tapered.

Lath: The Contractor shall furnish lath for use by the Engineer according to the following:

1. Shall be 1 1/8” x 1/2” x 48” (actual dimension).
2. Shall be furnished in securely banded (on each end) bundles of 50 pieces.
3. The material shall be kiln dried Douglas fir, oak or maple and surfaced on the 2 larger sides and without splits, pitch pockets, wane, knots or decayed wood.
4. The tapered end may be saw-cut tapered or pencil tapered.

In addition to the requirements of the special provision for construction layout stakes (Illinois Department of Transportation Check Sheet #10), the Contractor shall reestablish, monument, and tie all control points used to complete the work as specified including all PI's, PC's, PT's, and POT's. The type of monumentation used will be PK nails, iron pipes, RR spikes or as approved by the Engineer.

The cost of this work shall be included in the cost of CONSTRUCTION LAYOUT, and no additional compensation will be allowed.

TEMPORARY TOILETS

The contractor shall provide a temporary toilet facilities for the use of all contractors' personnel employed on the work site, and shall maintain same in proper sanitary condition. At completion, the facilities shall be removed and the premises left clean. The Engineer shall approve the location of the temporary toilets. The cost of this work shall be included in the cost of MOBILIZATION.

ADJUSTING WATER MAIN

Description. This work shall consist of adjusting existing water mains when directed by the Engineer where they are in conflict with new improvements or where the proposed construction will reduce the cover over the water main. All materials used in adjusting water mains shall meet the requirements of the owning agency's standards and shall be in accordance with the Standard Specification for Water and Sewer Main Construction in Illinois, latest edition. All adjustment in the line or grade of the existing water main shall be approved by the Engineer.

Materials. All materials, labor, and equipment necessary to adjust the water main shall be on hand before shutdown and cutting of the existing main. The Contractor shall take every precaution to hold the interruption of service to a minimum.

General. A minimum clearance of eighteen inches (18") shall be maintained between the adjusted main and improvement for which the adjustment was made. A downward adjustment will be required unless 5.5' of cover can be maintained for an upward adjustment or as approved by the Engineer.

Adequate precautions shall be taken to prevent contaminants from entering the existing main. The inside surface of all new materials used in the adjustment shall be cleaned of all foreign materials and swabbed with a solution of efficient bactericide before assembly. The adjusted section shall then be flushed with potable water.

The Contractor shall provide protection from movement of water main piping, plugs, caps, tees, valves, hydrants, and bends of 1 ¼ degrees or greater. Concrete thrust blocks shall be provided at all locations unless restrained joint type fittings are utilized. The Village of Buffalo Grove requires the use of Mega-Lug retainer glands at all connection of ductile iron water main with bends, tees, crosses, reducers and all other fittings. Cast-in-place concrete thrust block shall not be allowed for the Village of Buffalo Grove water main. The blocking shall be located between solid, undisturbed ground and the fitting to be anchored. The blocking shall be placed so that the fitting joints will be accessible for repair. The minimum width of thrust blocks shall be 12 inches. All wooden shims and wedges used to tighten precast thrust blocking shall be fully encased with poured concrete and the concrete shall have set before the trench is backfilled. When conditions prevent the use of concrete thrust block, restrained joints shall be used. Excluding the joints of any valve, bend, cross or tee, the first two joints beyond any valve, bend, cross or tee shall be restrained.

Forty-eight (48) hours prior to shutting down the existing main for the adjustments, the facility owner and all users that will be affected shall be notified in writing. The Contractor shall distribute notices of the shut down to the residents affected. The Contractor shall cooperate with the local agency personnel to locate valves necessary to isolate the work area. All valves will be operated by personnel from the owning agency.

Method of Measurement. ADJUSTING WATER MAIN shall be measured in place, in feet, of actual water main pipe installed.

Basis of Payment. This work will be paid for at the contract unit price per foot for ADJUSTING WATERMAIN of the size specified. This price shall include the cost of all materials, pipe, adapters, joint materials, fittings, retainer glands, blocking, trench backfill, removal and disposal of existing main, and all work and equipment necessary to make a complete and finished installation.

AGGREGATE BASE COURSE, TYPE B

Description. This work shall consist of furnishing and placing aggregate base course material on a prepared subgrade or subbase.

Materials. The aggregate shall meet the requirements of Article 1004.04 of the “Standard Specifications” except that:

The aggregate material shall be limited to crushed gravel, crushed stone, crushed concrete or RAP.

The RAP shall be well graded from coarse to fine. RAP that is gap-graded or single-sized will not be accepted.

The plasticity index requirements will be waived.

General. The work shall be performed according to Section 351 of the “Standard Specifications”.

Where sidewalk or driveway is adjacent to the back of curb, space between roadway and sidewalk or driveway aggregate subgrades shall be filled with aggregate instead of furnished excavation. The cost of this aggregate shall be paid for as "AGGREGATE BASE COURSE, TYPE B".

Method of Measurement. Aggregate Base Course, Type B will be measured for payment in tons according to Article 311.08(b) of the “Standard Specifications”. The following excess moisture content correction will apply to Aggregate Base Course, Type B:

When the unit of measurement for the aggregate is tons, the aggregate may be weighed in trucks or freight cars. The Contractor shall furnish or arrange for the use of scales of a type approved by the Engineer. If, at the time the Type B aggregate is weighed, it contains more than six percent of absorbed and free moisture by weight, a deduction for the amount of moisture in excess of this amount will be made in determining the pay quantity. Any aggregate that has been stockpiled will be weighed at the time it is incorporated into the work.

Basis of Payment. This work will be paid for at the contract unit price per ton for AGGREGATE BASE COURSE, TYPE B. The unit price shall include all equipment, materials and labor required to furnish, weigh and place the base course.

AGGREGATE FOR TEMPORARY ACCESS

Description: This work shall consist of furnishing and constructing temporary aggregate driveways and roads to maintain ingress and egress to all abutting properties during construction operations, or to provide pedestrian access connections for short-term durations.

Materials: The aggregate shall meet the requirements of Article 1004.04 of the “Standard Specifications” except that:

The aggregate material shall be limited to crushed gravel, crushed stone or crushed concrete. The plasticity index requirements and the requirement to add water at the central mixing plant will be waived.

General: The work shall be performed according to Article 402.10 of the “Standard Specifications” and the following:

Each temporary access shall be constructed to dimensions determined by the Engineer.

After the temporary aggregate access has served its purpose, the aggregate shall be removed. Suitable aggregate may be utilized for another purpose, such as embankment construction or driveway apron construction, with the approval of the Engineer.

Aggregate not reused, shall be removed and disposed of outside the right-of-way according to Article 202.03 of the “Standard Specifications”.

Method of Measurement: Aggregate for Temporary Access will be measured for payment in tons according to Article 311.08(b) of the “Standard Specifications”. Measurement will be made for the initial use of the aggregate only, regardless of the number of times the aggregate is moved and/or reused.

Basis of Payment: This work will be paid for at the contract unit price per ton for AGGREGATE FOR TEMPORARY ACCESS. The unit price shall include all equipment, materials and labor required to furnish, transport, place, maintain and remove the aggregate.

AGGREGATE SHOULDERS, TYPE B

Description. This work shall consist of furnishing, placing, shaping, and compacting aggregate on a prepared subgrade adjacent to the edges of the completed pavement structure or stabilized shoulder.

Materials. The aggregate shall meet the requirements of Article 1004.04 of the “Standard Specifications” except that:

The aggregate material shall be limited to crushed gravel or crushed stone.

The plasticity index requirements will be waived.

General. The work shall be performed according to Section 481 of the “Standard Specifications”.

Method of Measurement. Aggregate Shoulders, Type B will be measured for payment in tons according to Article 311.08(b) of the “Standard Specifications” except that payment will not be made for aggregate outside the plan width. The following excess moisture content correction will apply to Aggregate Shoulders, Type B:

When the unit of measurement for the aggregate is tons, the aggregate may be weighed in trucks or freight cars. The Contractor shall furnish or arrange for the use of scales of a type approved by the Engineer. If, at the time the Type B aggregate is weighed, it contains more than six percent of absorbed and free moisture by weight, a deduction for the amount of moisture in excess of this amount will be made in determining the pay quantity. Any aggregate that has been stockpiled will be weighed at the time it is incorporated into the work.

Basis of Payment. This work will be paid for at the contract unit price per ton for AGGREGATE SHOULDERS, TYPE B. The unit price shall include all equipment, materials and labor required to furnish, weigh and place the aggregate shoulder.

ANTI-GRAFFITI PROTECTION SYSTEM

Description. This work shall consist of the furnishing and application of an anti-graffiti coating to exposed concrete surfaces as scheduled in the plans.

General Requirements. The anti-graffiti protecting system shall consist of a permanent, color stable, UV, stain, chemical and abrasion resistant coating. The removal of graffiti from the protected surfaces shall be accomplished by applying a separate removal agent as recommended by the manufacturer of the permanent coating. The removal agent shall have the capability of completely removing all types of paints and stains. After graffiti removal there shall be no damage to the anti-graffiti coating or the surface to which it is applied. Additionally there shall be no evidence of ghosting, shadowing, or staining of the protected surface.

Qualifications. The anti-graffiti protection system shall be a product that has been commercially available for a period of at least five (5) years. Samples of the proposed material shall be supplied to the Engineer for testing. The contractor shall apply the material to a test

patch following the manufacturer's recommendation. After the manufacturer's recommended curing period, the Engineer will apply various types of graffiti material to the coating. After three (3) days the removal agent shall be used to remove the graffiti. If after graffiti removal the anti-graffiti coating is clean and undamaged, with no evidence of ghosting, shadowing or staining, then the anti-graffiti coating is approved for use.

Surface Preparation. Prior to application of the anti-graffiti coating, all designated surfaces shall be cleaned of all loose debris, previous coatings and all foreign matter by a method as recommended by the coating manufacturer and approved by the Engineer. All surfaces shall be thoroughly cleaned, dry and free of dust that might prevent penetration of the coating. New concrete should be thoroughly cured before application of the coating. Concrete surfaces shall be properly sealed according to the manufacturer's recommendations so the application of the system does not produce any noticeable long term change in color of the surfaces being treated. A technical representative of the manufacturer shall be present to approve surface preparation and application of the anti-graffiti protection system.

Weather Conditions. Coatings shall not be applied in the rain, snow, fog or mist, nor shall they be applied if these conditions are expected within twelve (12) hours of application. Coatings shall not be applied when surface or air temperatures are less than 40°F nor greater than 100°F, or is expected to exceed these temperatures within twelve (12) hours of application.

Application. The manufacturer's product data sheets and application guides shall be submitted to the Engineer prior to coating application. All information contained in the data sheets and application guides shall be strictly followed. All coatings shall be applied in the presence of the Engineer. The wet film thickness will be measured by the Engineer and shall be according to the manufacturer's recommendation. Application of the clear protective coatings shall take place after the application and curing of the STAINING CONCRETE STRUCTURES items as appropriate for the surface to be treated.

In a contrasting color of the same anti-graffiti system, the name of the system used and the date of application shall be stenciled in letters not to exceed 2 inches high. The location of the stencil shall be near one end of the work at the bottom of the surface to be protected. For projects greater than 3,000 sq. ft. near the bottom at the locations designated by the Engineer.

Method of Measurement. This work will be measured in place per square feet of surface area upon which the anti-graffiti protection system has been applied and accepted by the Engineer.

Basis of Payment. This work will be paid for at the contract unit price per square foot for ANTI-GRAFFITI PROTECTION SYSTEM which price shall be payment in full for the cleaning of designated surfaces, the application of the anti-graffiti coating, supplying the manufacturer's technical representative and supplying the initial quantity of cleaning agent.

BASE FOR TELESCOPING SIGN SUPPORT, SPECIAL

Description. This work shall consist of furnishing and installing a permanent underground base for a 2"x2" Telescoping Steel Sign Support Post. This base will be required when the support signs are to be installed on sidewalks, median islands or other concrete locations.

Materials. Materials shall be in accordance with the following;

1. STEEL TUBE. The steel tube shall have an outside dimension of 70mm x 70mm (2.756 inches by 2.756 inches). The length of the square tube shall be a minimum of 300mm (11.91 inches). The wall thickness must be 3.2mm (.125 inches). Two 90° flanges are to be welded on opposing sides of the square tube. The flanges will be located on the center line of the width of the tube, 152mm (6 inches) from the end of the tube. The flange will have a wall thickness of 3.2mm (.125 inches) and a total length of 63.5mm (2.50 inches). The entire tube is to be hot dipped galvanized so that the minimum uniform zinc coating is .053mm (.0021 inches).

2. POLYURETHANE SLEEVE. The polyurethane sleeve will consist of two sleeves. The lower sleeve will have a base which measures 79mm x 79mm (3.07 inches x 3.07 inches) with a minimum thickness of 5mm (.19 inches). The lower sleeve will narrow to 63.5mm (2.5 inches) where the sleeve fits inside the steel tube. The sleeve will have a thickness of .12mm (.47 inches). The overall height of the sleeve will measure 70mm (2.75 inches) with 65mm (2.55 inches) fitting inside the tube. A tapered opening will be 60mm (2.36 inches) deep to allow the square post to easily fit inside the sleeve. The beginning of the taper will measure 55mm (2.16 inches) and narrow to 51.1mm (2.03 inches) and at the end of the 12mm (.47 inch) long taper.

The upper sleeve will have a 52mm x 52mm (2.05 inch x 2.05 inch) opening to allow passage of 2"x2" square tube. The top of the upper sleeve will have flange 24mm (.93 inch) thick which measures 65mm x 65mm (2.55 inches x 2.55 inches) on the outside dimension. The flange tapers to a thickness of 5mm (.19 inches) to create an overall outside dimension of 79mm x 79mm (3.11 inches x 3.11 inches). The upper sleeve will measure 65mm x 65mm (2.55 inches x 2.55 inches) where the sleeve fits inside the galvanized steel tube. The thickness of the sleeve inside the tube will be 14mm (.55 inches). The sleeve has a surface of 70mm (2.75 inches) in length.

The polyurethane has the following general properties:

Shore hardness A	65	ASTM D2240
Tensile strength	22.6 Mpa	
Split tear	22 Kn/m	ASTM D470
Compression set	16%	ASTM D395

Method of Measurement. The base will be measured for payment in individual units complete in place.

Basis of Payment. This work will be paid for at the contract unit price each BASE FOR TELESCOPING SIGN SUPPORT, SPECIAL.

BLOCKWALL RECONSTRUCT

Description: This work shall consist of salvaging the existing retaining wall blocks and reconstructing the wall in its ultimate location.

General: Remaining bricks shall be disposed of in accordance with the Article 202.03 of the Standard Specifications. If the new bricks will need to be furnished they shall be identical to the existing bricks. The cost of furnishing new bricks shall be included in the cost of BLOCKWALL RECONSTRUCT.

Wall layout should be to the satisfaction of the engineer and in coordination with the property owner.

Basis of Payment: This work shall be paid for at the contract unit price per lump sum for BLOCKWALL RECONSTRUCT, which price shall include all equipment, storage, security, materials and labor required to reconstruct the wall.

CATCH BASIN, MANHOLE, INLET, DRAINAGE STRUCTURE, AND VALVE VAULT CONSTRUCTION, ADJUSTMENT, AND RECONSTRUCTION

Description. This work shall consist of constructing, adjusting, or reconstructing catch basins, manholes, inlets, or valve vaults, with frames and grates or lids, and constructing drainage structures with frames and grates.

General. The work shall be performed according to Section 602 of the “Standard Specifications” and the following:

Precast concrete adjustment rings and/or common brick shall not be used within Lake County right-of-way to adjust or reconstruct catch basin, manhole, inlet and valve vault structures. The Contractor may use Expanded Polypropylene (EPP), High Density Expanded Polystyrene, High Density Polyethylene (HDPE) or Recycled Rubber adjusting rings. The Contractor shall comply with the maximum adjustment height limit specified for each material. No additional compensation will be allowed for reordering rings of a different material to meet the adjustment height required. The cost of furnishing and installing adjustment rings shall be included in the unit price for each proposed adjusted or reconstructed structure.

To accommodate topsoil placement all type 8 grates installed on flat slab tops shall be adjusted to the plan grade with a minimum of 4” of adjusting rings. The cost of furnishing and installing adjustment rings shall be included in the unit price for each proposed drainage structure.

The cost of connecting existing storm sewer to proposed structures shall be included in the unit cost of the proposed structure. Additional pipe required to complete the connections will be paid for at the contract unit price for "STORM SEWER" of the type, size and class required.

All frames with closed lids to be furnished as part of this contract, for the construction, adjustment or reconstruction of manholes, catch basins, inlets, valve vaults, or meter vaults shall have cast into the lid one of the following words: Lids for storm sewer structures shall bear the word STORM. Lids for sanitary sewer structures shall bear the word SANITARY. Lids for water system structures shall bear the word WATER. Additionally, open grates or lids shall include the wording DUMP NO WASTE, DRAINS TO WATERWAYS. This work shall be included in the unit cost of the structure being constructed, adjusted or reconstructed.

All existing frames, grates, and lids that are being removed shall remain the property of the local Public Works Department. The Contractor shall deliver all replaced frames, grates and lids to the respective Public Works facilities as identified within the points of contacts section of the plans. The cost of all materials required and all labor necessary to comply with the above provisions will not be paid for separately, but shall be included in the cost of structure removal, adjustment, or reconstruction.

Frame elevations given on the plans are only to assist the Contractor in determining the approximate overall height of the structure. The adjustment of frames on all new structures to the final elevations shall be included in the cost of the new structures.

Basis of Payment. This work will be paid for according to Article 602.16 of the "Standard Specifications".

CHAIN LINK FENCE, 4' (SPECIAL); CHAIN LINK GATES (SPECIAL)

Description: This work shall consist of furnishing and installing a new fence and gates at the locations shown on the plans and/or designated by the Engineer.

General: Chain Link fences and gates shall be constructed according to Section 664 of the "Standard Specifications" except that it shall be coated with black vinyl at the direction of the Engineer and fences shall include the top rail.

Method of Measurement: CHAIN LINK FENCE, 4' (SPECIAL) will be measured for payment in feet, along the top of the new installed fence, from center to center of end posts and CHAIN LINK GATES (SPECIAL) per each gate installed.

Basis of Payment: This work will be paid for at the contract unit price per foot for CHAIN LINK FENCE, 4' (SPECIAL), which shall include the cost of the top rail and per each for CHAIN LINK GATES (SPECIAL). The unit price shall include all equipment, materials and labor required to furnish and erect the fence or gates.

COMBINATION CURB AND GUTTER

Description. This work shall consist of constructing concrete curb and gutter.

Materials. The materials shall meet the requirements of Article 606.02 of the “Standard Specifications”.

General. The work shall be performed according to Section 606 of the “Standard Specifications”, IDOT Standard Drawing 606001 and the following:

One inch expansion joints shall be constructed at maximum intervals of 150 feet.

The end treatments as shown on the plans shall conform to the applicable special details. Where no end treatment is specified, curb and gutter endings shall be transitioned to a flat section over the final six feet.

The curb and gutter along landscaping median shall pitch out towards the roadway unless shown otherwise on the plans. Combination concrete curb and gutter shall be paid for as COMBINATION CONCRETE CURB AND GUTTER of the type specified, regardless of the gutter slope.

The transition from the proposed curb and gutter section to a flat or depressed section (where there is no connection to existing curb and gutter) shall be accomplished in minimum of four feet, and will be paid for as COMBINATION CONCRETE CURB AND GUTTER of the type being constructed.

Method of Measurement. Combination Concrete Curb and Gutter will be measured for payment in feet. The measurement will be made along the face of curb according to Article 606.14 of the “Standard Specifications”. Transitions from one type of curb and gutter to another will be included in the measured quantities for the type having the largest cross sectional area of concrete. The transition length will be 10 feet unless otherwise shown on the plans.

Basis of Payment. This work will be paid for at the contract unit price per foot for COMBINATION CONCRETE CURB AND GUTTER, of the type specified. The unit price shall include all equipment, materials and labor required to construct the curb and gutter.

COMBINATION CURB AND GUTTER REMOVAL

Description: This work shall consist of the complete removal of existing curb and combination curb and gutter.

General: The work shall be performed according to Section 440 of the “Standard Specifications”, and the following:

Removal of Type B curb shall be paid for as "COMBINATION CURB AND GUTTER REMOVAL".

Method of Measurement: Curb removal and combination curb and gutter removal will be measured for payment in feet.

Basis of Payment: This work will be paid for at the contract unit price per foot for COMBINATION CONCRETE CURB AND GUTTER REMOVAL. The unit price shall include all equipment, materials and labor required to remove and dispose of the curb or curb and gutter.

CONCRETE STEPS

Description: This work shall consist of constructing concrete steps at locations shown on the plans or as directed by the Engineer.

General: This work shall be performed in accordance the applicable portions of Section 424 of the Standard Specifications, and the concrete step detail provided in the plans.

Method of Measurement: This work shall be measured for payment in CUBIC YARDS of CONCRETE STEPS constructed. Reinforcement shall not be measured for payment separately but shall be included in the unit bid price of CONCRETE STEPS without a change in unit price because of adjustment in plan quantities.

Basis of Payment: This work will be paid for at the contract unit price per CUBIC YARD for CONCRETE STEPS, which price shall include all labor, equipment and materials necessary to complete the work. Earthwork and subbase work associated with this construction shall not be paid for separately but shall be included in the unit cost of the CONCRETE STEPS.

DETECTABLE WARNINGS

Description. This work shall consist of furnishing and installing detectable warnings in concrete accessibility ramps.

Materials. The detectable warnings shall be cast iron panels of the sizes shown on the plans and shall meet the following material specification:

The detectable warning plate shall be constructed of gray iron meeting the requirements of Article 1006.14 of the "Standard Specifications" and ASTM A48, CLASS 30A, 30B or 35B; or cast ductile iron meeting the requirements of Article 1006.15 of the "Standard Specifications".

The coating system shall consist of a rust inhibiting epoxy primer and a finish coat.

The epoxy primer shall have the following properties:

Property	Test Method	Performance
Humidity	ASTM D1735	1000 Hours Minimum
Water Immersion	ASTM D870	250 Hours Minimum
Corrosion Resistance (Salt Spray)	ASTM B117	1000 Hours Minimum

Cold Rolled Steel Lab Panels

The finish coat shall be a powder coat and shall have the following properties:

Property	Test Method	Performance
Color	---	Federal Yellow
Corrosion Resistance (Salt Spray)	ASTM B117	1000 Hours Minimum

Cold Rolled Steel Lab Panels

General. The installation of detectable warnings shall meet the requirements of Article 424.09 of the “Standard Specifications”.

Method of Measurement. This work will be measured for payment in place installed, in square feet. The concrete area under the detectable warnings will be measured for payment as PORTLAND CEMENT CONCRETE SIDEWALK of the thickness specified, with no deductions made for the detectable warnings panels located within the ramp.

Basis of Payment. This work will be paid for at the contract unit price per square foot of DETECTABLE WARNINGS. The unit price shall include all equipment, materials and labor required to install the panels.

DOCUMENTATION CAMERAS

Description. This work shall consist of furnishing, installing and maintaining a documentation camera system including two (2) all-weather wide angle cameras and appurtenances to document and record the construction of the Weiland Road and Aptakisic Road. The photos will be archived and shall be viewable and downloadable via a password protected website. This work also includes system removal at the end of the construction.

The term "System" in this special provision refers to the cameras, supports, mounting poles, wiring, power supply, data storage devices, software, maintenance, permits and other components required to initially construct the System, and to keep it operational throughout the term of use as defined below.

Materials. All materials and equipment shall be in conformance with Standard Specifications. Components of the System not covered herein shall be as approved by the Engineer.

Construction Requirements

General. The general features of the System shall be as follows.

1. Term of Use: Designed for 24 hour, 7 days a week operation in all weather conditions for the duration of the construction.
2. Physical Security: Components of the system within reach of passersby shall be hardened and tamperproof. The Engineer may require additional security measures at any time during the duration of the construction.
3. Power Source: Shall be compatible with the system, and capable of powering the system throughout the term of use specified above. The Contractor shall provide plans sealed by a professional electrical engineer showing the means and method of providing power for the system.
4. Camera: The cameras shall be capable of producing digital high quality color images in all light and weather. Characteristics of the cameras used shall include as a minimum:
 - Weather resistant housing
 - Lockable camera casing
 - Thermostatically controlled heater, defroster and blower
 - Impact resistant viewing window
 - Adjustable camera mount
 - Window wiper
 - 1/2.5 CCD Imager
 - 6.0 Megapixel Imager
 - F-Stop of F/2.7 - F/3.5
 - Maximum resolution of 2816 x 2112 pixels
 - Wide angle adapter of .75x
 - Motorized zoom lens with wide angle adapter 4.5mm - 54mm
 - Zoom 12x optical, 4x digital
 - Auto ISO
 - Auto shutter
 - Auto white balance
 - Auto focus
 - IP addressing dynamic or static
 - Operational temperature range -40°F to 120°F
 - Image stabilizer
5. Data Storage: The system shall record digital photos every 15 minutes and archive the photos for remote viewing via a password protected website throughout the duration of the construction. The digital photos shall be tagged with date and time and shall be saved in a manner which will allow easy retrieval and sequencing. The photo files on the website shall be full resolution and shall be available for download to users of the website

at any time during construction. The data storage system shall record the photos at full resolution. Photos taken by each camera shall be stored separately. Photos from each camera shall be stored on two sets each of DVD's or similar file storage mechanism and provided to the County at the time of removal.

6. Data Backup: The system shall store the photos in a primary location continuously and backup the photos in a separate location, and by a method, approved by the Engineer.
7. Time Lapse Video: The system shall be capable of creating a time lapse video of the complete construction, or any portion thereof, at the end of the project construction or at any time during the project construction. Provide two time lapse videos at any point during the construction at the request of the Engineer, within 30 days of the request, and 1 final time lapse video within 30 days of the completion of construction. Each time lapse video submission shall include five copies on DVD.
8. Ownership: The photos taken by the system shall be the sole property of the County.

Installation: Installation of system shall be as approved by the Engineer. Submit plans and manufacturer documentation to the Engineer for approval within 30 days of receiving notice to proceed. The system shall not be ordered prior to obtaining the Engineer's approval. The system shall be installed as soon as practicable after approval by the Engineer. The plans shall address all components of the system.

1. Camera Supports: The cameras are planned to be located to have the view of the proposed detention pond. The location and elevation shall be as specified by the Engineer. Supports shall be designed so that vibration will not affect photo quality. Supports shall be designed by a Structural Engineer licensed in the State of Illinois.
2. Camera Angle and Direction: The cameras shall be positioned on their supports to provide the vantage required by the Engineer.
3. Conflicts: All components of the system shall be located so as to not interfere with construction operations. The system components shall be located where they will not need to be relocated for the duration of the construction.
4. Data Storage: Install per approved plans.
5. Data Access: Password and level of security shall be as specified by the Engineer. A copy of the software and manuals used to create and edit the photos and video shall be provided to the County.
6. Testing and Approval: Once installed, the entire system shall be tested for a minimum of 24 hours. Also, provide a DVD to the Engineer within the first 2 weeks of operation containing 5 days of photos from both cameras, and a time lapse video corresponding to

these photos, to confirm that the system will produce acceptable results. Make modifications to the system as specified by the Engineer.

Maintenance: Maintain all equipment and provide for a seamless operation of the system. Allow no device to remain inoperable for a period longer than 48 hours.

Removal: Removal of system shall be performed after construction is complete, and at the discretion of the Engineer.

Basis of Payment: This work will be paid for at the contract unit lump sum price for DOCUMENTATION CAMERAS. Cost includes all labor, equipment and materials required to furnish, install, maintain and remove the cameras, software, supports, mounting poles, power source, storage devices, backup, cable, permits, power for all components, and all other appurtenances and permits required for the operation of the system for duration of construction.

DRAINAGE STRUCTURES TO BE CLEANED;
CLEANING DRAINAGE SYSTEM

Description. This work shall consist of cleaning drainage structures of all types and sizes as designated on the plans or as directed by the Engineer.

Materials. Equipment for cleaning pipe lines includes hoses, rodding machines, balls, hydraulic cleaners, root cutters, small clam shell buckets, steel porcupines, pumps, or other suitable and approved means. Water used for cleaning and flushing pipes shall be fresh and free of oils, acid, salt, alkali, organic matter, or any other deleterious substances. The Contractor shall provide all water for the cleaning operation.

Methods. The Contractor shall be responsible for the proper operation of the drainage system during the cleaning operations. The safe control of flows shall be accomplished by the Contractor such as to preclude an injury to persons or property due to flooding. The Contractor shall clean and flush those drain lines designated on the plans or as designated by the Engineer by use of pressure hoses, suction pumps, and/or any other methods required to perform this work. A suitable weir or dam shall be constructed in the nearest downstream manhole or catch basin in such a manner that debris material will be trapped. Under no circumstances shall such material be passed on from one section to the next.

Each manhole or catch basin shall be cleaned independently of other portions of the drainage system, and shall be cleaned to the satisfaction of the Engineer.

The contractor shall maintain flows through sewer systems at all times. The existing structures shall be inspected before construction starts. As directed by the Engineer, any accumulation of material in the structure due to construction operations shall be removed by the contractor at his expense.

Any loose mortar shall be removed from the pipe inlet joints. New mortar shall be applied as required.

Method of Measurement. DRAINAGE STRUCTURES TO BE CLEANED will be measured per each for such drainages structures actually cleaned, regardless of type or size, in accordance with the plans and/or as directed by the Engineer. CLEANING DRAINAGE SYSTEM will be measured in linear feet from center-to-center of drainage structures for all pipe lines actually cleaned, regardless of the sizes of pipe, in accordance with the plans and/or as directed by the Engineer.

Basis of Payment. DRAINAGE STRUCTURES TO BE CLEANED will be paid for at the contract unit price per each for such drainages structures actually cleaned, regardless of type or size, in accordance with the plans and/or as directed by the Engineer. CLEANING DRAINAGE SYSTEM will be paid for at the contract unit price per foot for all pipe lines actually cleaned, regardless of the sizes of pipe, in accordance with the plans and/or as directed by the Engineer.

DRY RUBBLE STONE OR BROKEN CONCRETE TREE WELLS

Description. This work shall consist of furnishing and constructing rubble stone or broken concrete tree wells in sections of proposed embankment for the purpose of preserving existing trees.

Materials. The dry rubble stone and/or broken concrete shall have a minimum size of 6" x 6" x 4" [length x width x thickness].

The bedding stone shall meet the requirements of Article 1005.01 of the "Standard Specifications" except that:

The bedding stone shall be limited to class A-3. Limestone shall not be allowed.

The vents and drains shall meet the requirements of Section 601 of the "Standard Specifications" except that:

The pipes shall be limited to:

- (m) Perforated Polyvinyl Chloride (PVC) pipe [1040.03 (b)]
- (n) Perforated Corrugated Polyvinyl Chloride (PVC) pipe with a smooth interior [1040.03 (c)]

The pipe shall be wrapped with a fabric envelope meeting the requirements of Article 1080.01 of the "Standard Specifications".

Construction Requirements. The work shall be performed according to the LCDOT Standard Drawing LC1015 and the following:

The outside limit of the 8” lift of bedding stone, the limit of the filter fabric, and the placement of the lateral drain and the vent drains shall be to the drip line of the tree or to limits set by the Engineer. To assist the Contractor in estimating quantities, a table comparing the approximate diameter of the drip line to the diameter of the tree trunk is included on LC1015.

The 8” lift of bedding stone is placed on top of the existing ground area under the crown of the tree as shown on LC1015. The bedding stone and filter fabric shall extend from the outside edge of the stone out to the drip line or to limits set by the Engineer. The bedding stone shall be placed in a like manner to the bedding under riprap as described in Section 281 of the “Standard Specifications”.

The 4” diameter perforated lateral vents and drains shall be installed according to Section 601 of the “Standard Specifications”.

Method of Measurement. The tree well will be measured in place and an average height of the stone determined. For payment, the inside diameter of the well will be the diameter of the tree plus 2’. For payment, the thickness of the stone shall be 12”. The volume of the well shall be calculated, as the average height times the calculated area of the 12” thick stone, in cubic yards.

Basis of Payment. This work will be paid for at the contract unit price per cubic yard for DRY RUBBLE STONE OR BROKEN CONCRETE TREE WELLS. The work shall include all equipment, materials and labor necessary to install the tree well according to LC1015 and this Special Provision. All pipe vents, drains, caps, and filter fabric shall be included in unit price.

DUST CONTROL, SPECIAL

Description. This work shall consist of applying a dust retardant to the project roadways at the request of the Engineer.

General. This work shall be done in accordance with Article 107.36 of the “Standard Specifications” except as modified herein.

Materials. The Contractor may use any dust retardant he so chooses as long as the specified dust retardant has been approved by the Engineer. If applied at the discretion of the Contractor, no additional compensation shall be allowed.

The dust retardant shall consist of a non-toxic, non-hazardous, and non-flammable material.

Method of Measurement. The Contractor shall ensure that any piece of equipment used for the applying of the dust retardant shall be equipped with a metering device to account for the quantity of dust retardant used. For each day that dust retardant is applied, the Contractor and the Engineer shall agree on the volume of dust retardant used.

Basis of Payment. This work shall be paid for at the contract unit price per gallon for DUST CONTROL, SPECIAL, which price shall include all labor, materials, and equipment necessary to perform the work herein.

EARTH EXCAVATION

Description: This work shall consist of the excavation and transportation of suitable excavated material to embankment locations throughout the limits of the project. This work shall also consist of the excavation, transportation and off-site disposal of excess.

For this Project the Earth Excavation shall consist of:

1. *Excavation to the subgrade elevation.*
2. *Excavation for topsoil placement.*
3. *The removal of existing hot-mix asphalt pavement and aggregate base course not included in any other pay item.*
4. *Undercutting, as determined by the Engineer to include:*
 - a. *Removal of existing topsoil under proposed embankment.*
 - b. *Removal of unsuitable material in wet areas.*
5. *Undercutting, based on the recommendations of the soil survey and report.*
 - a. *An estimated quantity of excavation for undercutting has been included in the quantity of Earth Excavation and is shown on the plans.*
Undercutting may be employed only at the discretion of the Engineer after it has been determined that the provisions of Section 301 of the "Standard Specifications" will not yield sufficient results to allow the timely progress of the project.
 - b. *Undercutting may be employed only at the discretion of the Engineer after it has been determined that the provisions of Section 301 of the "Standard Specifications" will not yield sufficient results to allow the timely progress of the project.*

General: This work shall conform to the requirements of Section 202 of the "Standard Specifications" and the following:

All suitable excess material from sewer trenches, side roads, entrances or other necessary excavations may be used in the construction of the roadway. Placement and compaction of this material shall be considered included in the unit price for Earth Excavation.

Excavation required to: clean side road ditches, construct driveways, and/or construct side road approaches, will not be paid for separately, but shall be considered included in the unit cost of Earth Excavation.

Earth moved more than once due to construction staging and/or procedures selected by the Contractor, will not be paid for separately, but shall be considered included in the unit cost of Earth Excavation.

Method of Measurement: Earth Excavation will be measured in its original position and the volume in cubic yards computed by the method of average end areas.

Basis of Payment: This work will be paid for at the contract unit price per cubic yard for EARTH EXCAVATION. The unit price shall include all equipment and labor required to excavate, transport and distribute earth.

ENGINEER'S FIELD OFFICE, TYPE A (MODIFIED)

Description. This work shall consist of furnishing and maintaining in good condition, for the exclusive use of the Engineer, a weatherproof building at a location approved by the Engineer.

General. The field office shall meet the requirements of Article 670.02 of the "Standard Specifications", and the following:

- The field office and the required equipment, supplies and services shall meet the approval of the Engineer.
- The copy machine on site shall be capable of scanning to pdf.
- An electric pencil sharpener shall be included in the field office equipment.
- A hand sanitizer shall be included in the restroom facilities.

Penalty. Failure by the Contractor to meet the specified occupancy date for any field office shall be grounds for assessment of a penalty of **\$100** per day for each calendar day thereafter that such facility remains incomplete in any respect. Failure by the Contractor to equip, heat, cool, power, supply or clean the field office shall be grounds for assessment of a penalty of **\$100** per day for each calendar day that the field office remains incomplete after receipt of written notification from the Engineer. Such penalty shall be deducted from monies due or to become due the Contractor under the Contract.

Basis of Payment. This item will be paid for as described in the Article 670.07 of the "Standard Specifications" at the contract unit price per calendar month for ENGINEER'S FIELD OFFICE, TYPE A (MODIFIED). The unit price shall include all supplies, equipment, materials and labor required to furnish and maintain the field office.

EXPLORATION TRENCH, SPECIAL

Description. This work shall be done in accordance with Section 213 of the Standard Specifications except as modified herein. This item shall consist of excavating a trench at the locations directed by the Engineer for the purpose of locating existing TILE LINES, GAS LINES, and other UTILITIES within the construction limits of the proposed improvement.

General. The trench shall be deep enough to expose the utility, and the width of the trench shall be sufficient to allow proper investigation to determine if the utility needs to be replaced.

The exploration trench shall be backfilled with trench backfill at the direction of the Engineer meeting the requirements of the Standard Specifications. This shall be paid for at the contract unit price for trench backfill.

Method of Measurement. An estimated length of exploration trench has been shown in the summary of quantities to establish a unit price only, and payment shall be based on the actual length of trench explored without a change in unit price because of adjustment in plan quantities.

Basis of Payment. This work shall be paid for at the contract unit price per foot (regardless of depth) for EXPLORATION TRENCH, SPECIAL, and no extra compensation will be allowed for any delays, inconveniences or damage sustained by the Contractor in performing the work.

FENCE REMOVAL

Description. This work shall consist of the removal and disposal of an existing fence from the project site regardless of the fence type.

General. The Contractor shall remove all components of the existing fence including any concrete used to anchor fence posts, bracing, guy wires, posts, and/or gates. All removed materials shall be disposed of outside the limits of the right-of-way according to Article 202.03 of the "Standard Specifications" and/or as directed by the Engineer.

Method of Measurement. This work will be measured for payment in feet, along the top of the existing fence, from center to center of end posts, including the length occupied by gates.

Basis of Payment. This work will be paid for at the contract unit price per foot for FENCE REMOVAL. The unit price shall include all equipment, materials and labor required to remove and dispose of the fence.

FIRE HYDRANTS TO BE ADJUSTED

Description: This item consists of vertical adjustment of fire hydrants where called for on the plans or as directed by the Engineer. The construction of water mains and appurtenances shall

conform to Section 561 and 564 of the Standard Specifications for Road and Bridge Construction and the Standard Specifications for Water and Sewer Main Construction in Illinois.

General: Where called for on the plans or as directed by the Engineer, fire hydrants with auxiliary valves shall be vertically adjusted to meet the proposed final grade.

Any fire hydrant damaged by the Contractor shall be repaired at his/her own expense.

The work shall be performed in a manner approved, written or orally, by the Engineer of the municipality, or the Water District.

Fire hydrants shall only be adjusted with extensions and parts as described in the special provision for FIRE HYDRANT WITH AUXILIARY VALVE AND VALVE BOX.

Method of Measurement: This work will be measured for payment as EACH hydrant to be vertically adjusted.

Basis of Payment: This work will be paid for at the contract unit price EACH for FIRE HYDRANTS TO BE ADJUSTED, which price shall include all labor, equipment and materials necessary to complete the work.

FIRE HYDRANTS TO BE MOVED (SPECIAL)

Description: This work shall consist of moving an existing fire hydrant to a new location as called out on the engineering plans, or as directed by the Engineer.

General: This work shall be done in accordance with Section 564 of the Standard Specifications for Road and Bridge Construction and Section 46 of the Standard Specifications of Water and Sewer Main Construction in Illinois, except as modified herein and as shown on the details on the plans. This item includes the removal of an existing fire hydrant as shown on the plans. This item also includes installation of a cap or plug at the existing tee, after the existing auxiliary valve, installation of new hydrant lead piping; new valve box (unless provided with the new hydrant), thrust blocking, backfill and any necessary fittings.

All new piping shall be cement lined, Class 52 Ductile Iron with fittings in accordance with AWWA C104-80, C110-82, and C151-81.

All valve boxes shall be the same size and type as those existing.

All work including the installation of a cap after the tee, new pressure connections, and operation of valves shall be coordinated with the Village.

Disinfecting shall be in accordance with AWWA C601 for Disinfection Procedures when cutting into or Repairing Existing Mains.

Prior to any work on the water system, the dimensions of the existing main shall be verified to assure proper sizing of new fittings. All water main work shall be coordinated so that there are no extended water main shut-downs.

Method of Measurement: This work will be measured for payment as EACH structure to be moved.

Basis of Payment: This work will be paid for at the contract unit price EACH for FIRE HYDRANTS TO BE MOVED (SPECIAL). The unit price shall include all labor, equipment and materials necessary to complete the work. The unit price shall include all equipment, materials and labor required to move the fire hydrant and connect to the water main. Should new hydrant be provided at the direction of the Engineer, it will be paid for separately as FIRE HYDRANT WITH AUXILIARY VALVE AND VALVE BOX.

FIRE HYDRANTS TO BE RELOCATED

Description: This work shall consist of the relocation of an existing fire hydrant as called out on the engineering plans, or as directed by the Engineer.

General: This work shall be done in accordance with Section 564 of the Standard Specifications for Road and Bridge Construction and Section 46 of the Standard Specifications of Water and Sewer Main Construction in Illinois, except as modified herein and as shown on the details on the plans. This item includes the removal of an existing fire hydrant as shown on the plans. This item also includes installation of a cap or plug at the existing tee, after the existing auxiliary valve, installation of new hydrant lead piping; removal and replacement of required water main line; new valve box (unless provided with the new hydrant), thrust blocking, backfill and any necessary fittings.

All new piping shall be cement lined, Class 52 Ductile Iron with fittings in accordance with AWWA C104-80, C110-82, and C151-81.

All valve boxes shall be the same size and type as those existing.

All work including the installation of a cap after the tee, new pressure connections, and operation of valves shall be coordinated with the Village.

Disinfecting shall be in accordance with AWWA C601 for Disinfection Procedures when cutting into or Repairing Existing Mains.

Prior to any work on the water system, the dimensions of the existing main shall be verified to assure proper sizing of new fittings. All water main work shall be coordinated so that there are no extended water main shut-downs.

Method of Measurement: This work will be measured for payment as EACH structure to be relocated.

Basis of Payment: This work will be paid for at the contract unit price EACH for FIRE HYDRANTS TO BE RELOCATED. The unit price shall include all labor, equipment and materials necessary to complete the work. The unit price shall include all equipment, materials and labor required to relocate the fire hydrant and connect to the water main. Should new hydrant be provided at the direction of the Engineer, it will be paid for separately as FIRE HYDRANT WITH AUXILIARY VALVE AND VALVE BOX.

FIRE HYDRANT WITH AUXILIARY VALVE AND VALVE BOX

Description. This work shall consist of the supplying and installation of a new fire hydrant with auxiliary valve and valve box as called out on the engineering plans, or as directed by the Engineer.

General. This work shall be performed in accordance with Section 564 of the Standard Specifications and with applicable portions of Section 45 of the Water and Sewer Specifications.

Fire hydrants shall be Waterous Pacer Model WB 67-250, AWWA C502, with two nozzles of two and one half inch and one nozzle of four and one half inch, with threads conforming to National Standard Specifications. Fire hydrants shall be painted fire engine red above ground. All trim shall be stainless steel. Fire hydrants and auxiliary boxes shall be direct flange-to-flange connections.

Each hydrant shall incorporate a six-inch (6") auxiliary valve and box. Valve boxes shall be Tyler 664-S with the lid embossed "WATER". Rubber valve box stabilizers shall be required. All auxiliary valves shall be located a minimum of thirty inches (30") and a maximum of thirty-six inches (36") from the hydrant. Connection of the hydrant and auxiliary valve assembly shall be made with a six-inch (6") diameter ductile iron water main. The installation of the fire hydrants and auxiliary valves shall be in accordance with the attached hydrant details. All auxiliary valves shall incorporate lacing rods from valve to tee.

Hydrants shall be set plumb, with the nozzle and steamer connection facing the roadway. The steamer connection shall be set not less than eighteen inches (18") nor more than twenty-four inches (24") above finished grade. The frangible section (Breakaway type) shall be set with the break line flange located one inch above finished grade. Fire hydrant bases and auxiliary valves shall be set on a precast concrete block to provide firm support for the base. The bases shall be braced with solid concrete blocking between the base and undisturbed trench wall to counteract the reaction thrust of water pressure at the base. Mechanical joint anchoring fitting or approved restrained joints shall be provided.

The connecting pipe and auxiliary valve shall be wrapped with polyethylene wrapping. The fire hydrant stem shall not be wrapped.

The fire hydrant barrels shall be braced during backfilling. The Contractor shall ensure that the drain hole is not blocked. Washed coarse stone shall be placed at and around the base for proper drainage, as shown on the Village's detail included in the plans. The stone shall be covered with plastic or filter fabric meeting the approval of the Engineer prior to backfilling. Backfill material shall be placed and compacted in 6-inch layers around the hydrant and auxiliary gate valve.

If the hydrant assembly comes pre-assembled, the Contractor shall inspect the hydrant and retighten any bolts that may have become loose during transportation of the hydrant from the factory to the site.

Fire hydrants may require field adjustment from grades listed on the plans. Any adjustment to the hydrant to meet grade shall be included in the cost of the hydrant.

Forty-eight (48) hours prior to shutting down the existing main for the adjustments, the facility owner and all users that will be affected shall be notified in writing. The Contractor shall distribute notices of the shut down to the property owners affected. The Contractor shall cooperate with the local agency personnel to locate valves necessary to isolate the work area. All valves will be operated by personnel from the owning agency.

The Contractor will be responsible for repainting any fire hydrant that is chipped, scraped or otherwise cosmetically damaged before, during or after installation. The process and painting subcontractor will be subject to the review and approval by the Engineer as coordinated with the Village, **prior to repainting**.

Basis of Payment. New fire hydrants will be paid for at the contract unit price EACH for FIRE HYDRANT WITH AUXILIARY VALVE AND VALVE BOX, which price shall include all excavation; furnishing all appurtenances, including thrust blocks and extensions authorized by the Engineer; backfilling, including coarse aggregate; and disposal of excavated materials. The unit price shall include all equipment, materials and labor required to install the unit and connect to the water main.

FLOCCULATION LOGS; FLOCCULATION POWDER

Description. This work shall consist of furnishing and applying Flocculation Logs and/or Flocculation Powder on the project site to minimize soil erosion, bind soil particles, remove suspended particles, and act as a construction aide.

Materials. The polymer shall be a water soluble anionic polyacrylamide (PAM). PAMs are manufactured in various forms to be used on specific soil types. Using the wrong PAM may result in performance failures. All site specific soils shall be tested by a Certified Professional in Erosion and Sediment Control (CPESC) each time a PAM is used. The following measures shall be adhered to:

- a) Toxicity: All vendors and suppliers of PAM, PAM mix, or PAM blends, shall supply a written toxicity report, which verifies that the PAM, PAM mix or PAM blends, exhibits acceptable toxicity parameters which meet or exceed the requirements for the State and Federal Water Quality Standards. **Cationic formulations of PAM, PAM blends, polymers or Chitosan are not allowed.**
- b) Performance: All vendors and suppliers of PAM, PAM mix or PAM blends shall supply written “site specific” testing results, demonstrating that a performance of 95% or greater of nephelometric turbidity units (NTU) or total suspended solids (TSS) is achieved from samples taken. In addition to soil testing, a CPESC shall design the installation plan for the polymers based on mix time and point of entry.
- c) Safety: PAM shall be mixed and/or applied in according to all Occupational Safety and Health Administration (OSHA) material safety data sheet (MSDS) requirements and the manufacturer’s recommendations for the specified use.

Construction Requirements:

Flocculation Powder Dry Form Application: Dry form powder may be applied by hand spreader or mechanical spreader. Pre-mixing of dry form PAM into fertilizer, seed or other soil amendments is allowed when approved by the CPESC. The application method shall insure uniform coverage of the target area. Application rates typically range from 10 – 18 pounds per acre.

Flocculation Powder Hydraulically Applied Application: PAM is typically used as part of hydraulically applied slurry containing at least mulch and seed to quickly establish vegetation (temporary or permanent). When used without seed, PAM provides temporary erosion protection for cut & fill surfaces. Application rates typically range from 10 - 18 pounds per acre.

Flocculation Powder Installation constraints: Flocculation Powder shall be applied to non-frozen soil surfaces, only. An unfrozen soil surface is defined as any exposed soil surface free of snow, standing water, ice crystals, etc., which is comprised of discrete soil particles unbound to one another by surface or interstacy ice. The temperature shall be at least 40° F, when hydraulically applying the Flocculation Powder

Flocculation Log Installation: A Flocculation Log is a semi-hydrated polyacrylamide block that is placed within storm water and/or construction site drainage to remove fine particles and reduce NTU values. Placement of Flocculation Logs should be as close to the source of particle suspension as possible. Ideal performance of the Flocculation Logs occurs when the product is used in conjunction with other best management practices (BMPs). Each Flocculation Log is specifically formulated for the soil and water chemistry at the site. Soil and water samples will determine which formula Flocculation Log is needed. The samples will also aid in determining proper placement.

Flocculation Products Maintenance plan: As with any other BMP, this system will need to have a maintenance plan in place. The Contractor shall perform the following items as directed by the Engineer:

1. Reapplication of Flocculation Powder to disturbed areas
2. Reapplication of Flocculation Powder to temporary areas
3. Replacement of Flocculation Logs
4. Adjustments to the Storm Water Pollution Prevention Plan

Method of Measurement. An estimated quantity of Flocculation Logs is included in the summary of quantities to establish a unit price only. A typical dry log weighs about 10 pounds and is approximately 5" x 4" x 12". Payment will be made based on the actual number of logs used. An estimated quantity of Flocculation Powder is included in the summary of quantities to establish a unit price only. Payment will be made based on the actual quantity (weight) of powder applied.

Basis of Payment. FLOCCULATION LOGS will be paid for at the contract unit price per each. FLOCCULATION POWDER will be paid for at the contract unit price per pound. Payment will be based on the actual number of logs and/or the actual weight of the powder used without a change in unit price because of adjustment in plan quantities, and no extra compensation will be allowed for any delays, inconveniences or damage sustained by the Contractor in performing the work. The unit price shall include all equipment, materials and labor required to furnish and apply flocculation logs and/or flocculation powder.

FORM LINER TEXTURED SURFACE

Description: This work will consist of providing a textured finish on the new cast-in-place concrete surfaces as detailed in the plans.

Materials: The materials shall be according to Article 503.02 of the "Standard Specifications" and the following:

The patterning of the form liner shall appear natural and non-repeating. Seam lines or match lines caused from two or more molds coming together will not be apparent when viewing final wall.

The molds shall not compress more than ¼ inch when concrete is poured at a rate of 10 vertical feet per hour. The molds shall be removable without causing deterioration of surface or underlying concrete.

The forms shall be constructed so that the completed concrete structures conform to the shape, lines and dimensions of the members of the approved pattern. The forms shall be properly braced or tied together to maintain position and shape. The forms shall be made sufficiently tight to

prevent leakage of the mortar. The formwork shall have the strength and stability to ensure finished concrete dimensions within the tolerances specified herein.

The following table summarizes the locations, form liner patterns, and colors for the textured surface:

Wall Type	Retaining Wall Finish/Color
Culvert & Wingwalls	Rustic drystack, Three color, buff, tan brown
MSE Wall	Rustic drystack, Three color, buff, tan brown

The form ties shall be made of either metal or fiberglass. Metal ties, which result in a portion of the tie permanently embedded in the concrete, shall be designed to separate at least one inch back from finished surface, leaving only a neat hole that can be plugged with patching material. Contractor shall submit the type of form ties to the Engineer, for approval prior to use in this work,

The joints shall be colored to simulate real mortar.

Class SI concrete used for cast-in-place structures shall contain a high range water-reducing admixture according to Article 1021.03(c) of the “Standard Specifications” to obtain a 5”-7” slump.

Sample Panel: The Contractor shall select a form liner pattern that satisfies the requirements in the above table. The form liner shall be according to Article 503.06(a) and the following:

The Contractor shall submit to the Engineer one (1) specification and catalog cut sheet for the style(s) of architectural form liner proposed for use on the project. Note that the same style of form liner shall be used on all surfaces within the projects limits. The submittal shall be made no later than 14 calendar days from the date of notification to proceed with the contract. Upon receipt of the information, the Engineer, in consultation with Lake County and other local government agencies will have 30 calendar days to approve and notify the Contractor of which style of form liner is to be used on the project.

Upon receipt of notification of the style of form liner to be used or if the Contractor is proposing a form liner from the pre-approved list, he/she shall submit a proposed procedure for obtaining the simulated finish. The procedure shall include plans and details for the form liner pattern and dimensions, and be submitted for the Engineer’s approval no later than 30 calendar days from the date of notification of approval of the style type. If such plans and details are not satisfactory to the Engineer, the Contractor shall make any changes as may be required by the Engineer at no additional cost to the Department.

Upon approval of the form liner plans and details, the Contractor shall submit a 3' by 3' (minimum) sample concrete panel of the simulated stone masonry finish. The sample panel shall be delivered and positioned on the job site at a location to be determined by the Engineer. The sample shall also include the concrete stain if it is included in the contract.

General: The work shall be performed according to Article 503.06 of the "Standard Specifications" and the following:

The form liners shall be installed according to the manufactures' recommendations to achieve the highest quality concrete appearance possible. The form liners shall withstand the concrete placement pressures without leakage, physical or visual defects.

The Contractor shall clean the form liners, removing any buildup prior to each use. The Contractor shall inspect each form for blemished or tears and make repairs as needed following manufacturer's recommendations.

The Contractor shall install the form liners with less than ¼ inch separation between them. The molds shall be attached securely to the forms following manufacturer's recommendations. The panels shall be attached to each other with flush seams and seams filled as necessary to eliminate visible evidence of seams in the cast concrete.

The liner butt joints shall be blended into the pattern so as to eliminate visible vertical or horizontal seams and conspicuous form butt joint remarks. The liner joints shall fall within patterns joints or reveals. The finished textures shall be continuous without visual disruption and properly aligned over adjacent and multiple liner panels. Continuous or single liner panels shall be used where liner joints may interrupt the intended pattern. Panel remnants shall not be pieced together.

The Contractor shall notify the Engineer at least 48 hours prior to placing concrete. Concrete shall not be placed until the Engineer has inspected the formwork and the placement of reinforcing bars for compliance with the plans.

The Contractor shall apply the form release agent to all surfaces of the form liner which will come in contact with concrete, according to the manufacturers' recommendations.

The Contractor shall employ proper consolidation methods to ensure the highest quality finish. Internal vibration shall be achieved with a vibrator of appropriate size, the highest frequency and low to moderate amplitude. Concrete placement shall be in lifts not to exceed 1.5 feet. Internal vibrator operation shall be at appropriate intervals and depths and withdrawn slowly enough to assure a minimal amount of surface air voids and the best possible finish without causing segregation. An external form vibrator may be required to assure the proper results. The use of an external form vibrator must be approved by the form liner manufacturer and the Department.

The Contractor shall coordinate concrete pours to prevent visible differences between individual pours or batches. Concrete pours shall be continuous between construction or expansion joints. Cold joints shall not occur within continuous form liner pattern fields.

The form liners shall be stripped between 12 and 24 hours as recommended by the manufacturer. When stripping the forms the Contractor shall avoid creating defects in finished surface.

Wall ties shall be coordinated with the liner and form to achieve the least visible result. Place form ties at thinnest points of molds (high points of finished wall). Neatly patch the remaining hole after disengaging the protruding portion of the tie so that it will not be visible after coloring the concrete surface

Where an expansion joint must occur at a point other than at mortar or rustication joints, such as at the face of concrete texture, which is to have the appearance of stone, consult manufacturer for proper treatment of expansion material.

Curing methods shall be according to Article 1020.13 of the "Standard Specifications" and compatible with the desired aesthetic result. The use of curing compounds will not be allowed. No rubbing of flat areas or other repairs should be required after form removal. The finished exposed formed concrete surfaces shall be free of visible vertical seams, horizontal seams, and butt joint marks. Grinding and chipping of finished formed surfaces shall be avoided.

Method of Measurement: Form Liner Textured Surfaces will be measured for payment in place and the area computed in square feet.

Basis of Payment: This work will be paid for at the contract unit price per square feet for FORM LINER TEXTURED SURFACE.

FRAMES AND GRATES, TYPE 11V

Description. This work shall consist of providing Type 11V frames and grates where identified on the plans or as directed by the Engineer.

General. The grates shall be as shown on the Standard 604056.

At the locations of depressed curb where curb grates are called out on the plans or as directed by the Engineer, a curb grate will need to be provided instead of curb box, which cost shall be included in the cost of FRAMES AND GRATES, TYPE 11V or structure being constructed.

Method of Measurement. This work shall be measured for payment per each grate installed.

Basis of Payment. This work shall be paid for at the contract unit price per each for CATCH BASINS, MANHOLES, or INLETS of the type or type and diameter specified, and with the TYPE 11V FRAME AND GRATE, or per each for FRAMES AND GRATES, TYPE 11V, which price shall include all labor, materials, and equipment required to complete the work.

FURNISHED EXCAVATION

Description. This work shall consist of excavating suitable fill materials from off-site locations approved by the Engineer. The work shall also include transporting the materials to various locations throughout the project limits.

General. The work shall be performed according to Section 204 of the “Standard Specifications” except as follows:

This work shall also comply with the "Illinois State Agency Historic Resources Preservation Act" (Public Act 86-707, effective January 1, 1990). Under this Act:

1. The Contractor shall complete a Cultural and Natural Resources Review of Borrow Areas form for Borrow/Waste/Use Areas (BDE form 2289 3/14/16 included herein), along with all required attachments, and submit them to the Engineer at the earliest possible date.
2. The Engineer shall submit the Cultural and Natural Resources Review of Borrow Areas form to IDOT for review and approval. Any and all costs incurred, associated with said review and approval will be borne by the Contractor.
3. The Contractor shall not begin work on any Borrow/Use areas until the Cultural and Natural Resources Review of Borrow Areas form has been approved.

Method of Measurement. Furnished Excavation will be measured for payment in cubic yards according to Article 204.07 of the “Standard Specifications”.

Basis of Payment. This work will be paid for at the contract unit price per cubic yard for FURNISHED EXCAVATION. The unit price shall include all equipment, materials and labor required to excavate, transport and distribute the furnished material.

GRATING FOR CONCRETE FLARED END SECTION

Description. This work shall consist of furnishing and installing a flared end section grate of the diameter specified at locations shown on plans.

General. The work shall be performed according to Section 542 of the “Standard Specifications” and in accordance with the detail LC5403 included in the plans.

Method of Measurement. This work shall be measured for payment per each grating installed.

Basis of Payment. This work shall be paid for at the contract unit price per each for GRATING FOR CONCRETE FLARED END SECTION, which price shall include all labor, materials, and equipment required to complete the work.

INLET FILTERS

Description: This work shall consist of furnishing, constructing, maintaining, removing, and disposing of inlet filters as part of the project's temporary erosion control system.

General: The work shall be performed according to Section 280 of the "Standard Specifications", and the following:

During the construction operation when any loose material is deposited in the flow line of ditches, gutters or drainage structures so the natural flow of water is obstructed, the material shall be removed at the close of each working day.

At the conclusion of the construction operations all drainage structures shall be free from all dirt and debris. This work will not be paid for separately but shall be considered included in the unit cost of INLET FILTERS.

Method of Measurement: This work will be measured for payment as individual items and the unit of measurement will be each regardless of the size or type of inlet being protected.

Basis of Payment: This work will be paid for at the contract unit price per each for INLET FILTERS. The unit price shall include all work and materials necessary to properly install the inlet protection, maintain the inlet protection throughout the project, and to remove and dispose of the used materials at the completion of the project.

INLETS, SPECIAL

Description. This work shall consist of constructing the 8" Custom PVC surface drainage inlets. The ductile iron grates for each of these structures are to be considered an integral part of the surface drainage inlet and shall be furnished by the same manufacturer.

Materials. The drain basins required for this contract shall be manufactured from PVC pipe stock, utilizing a thermo-molding process to reform the pipe stock to the specified configuration. The drainage pipe connection stubs shall be manufactured from PVC pipe stock and formed to provide a watertight connection with the specified pipe system. This joint tightness shall conform to ASTM D3212 for joints for drain and sewer plastic pipe using flexible elastomeric seals. The pipe bell spigot shall be joined to the main body of the drain basin. The pipe stock used to manufacture the main body and pipe stubs of the surface drainage inlets shall meet the mechanical property requirements for fabricated fittings as described by ASTM D303, Standard for Sewer PVC Pipe and Fittings; ASSTM F1336 Standard for PVC Gasketed Sewer Fittings.

The grates furnished for all surface drainage inlets shall be ductile iron grates made specifically for each basin so as to provide a round bottom flange that closely matches the diameter of the surface drainage inlet. Metal used in the manufacture of the castings shall conform to ASTM

A536 grade 70-50-05 for ductile iron and ASTM A-48-83. Grates shall be provided painted black.

General. The work shall be performed according to Section 601 and 602 of the Standard Specifications and the following:

To maintain a one piece, leak proof structure the INLETS, SPECIAL body will be cut at the time to the height of the final grade. An 8" to 10" thick concrete ring will be poured under the grate and frame as recommended by details provided from the manufacturer.

Basis of Payment. This work shall be measured and paid for at the contract unit price per EACH for INLETS, SPECIAL which price shall include all labor, equipment, and materials necessary to perform said work.

JOINT TIES FOR CONCRETE PIPE

Description: This work shall consist of furnishing and installing joint ties for concrete pipe culverts and/or concrete storm sewers.

Materials: The steel threaded rod, eye bolts, sleeve nuts, hex nuts, and washers, shall meet the requirements of ASTM A 307. They shall be zinc-coated according to AASHTO M 232 or AASHTO M 298, Class 50. The galvanized coat shall be a maximum of 6 mils thick.

The steel cast-in-place inserts shall be zinc-coated according to AASHTO M 232, AASHTO M 298, Class 50 with galvanizing not to exceed 6 mils, or ASTM B 633 SC 3.

General: The installation of pipe culvert shall be according to Section 542 of the "Standard Specifications" and the installation of storm sewers shall be according to Section 550 of the "Standard Specifications" with the addition of the following:

The work shall include the installation of joint ties. The joint ties shall be installed according to the LCDOT standard LC5402 JOINT TIES FOR CONCRETE PIPE, included in the plans. The ties shall be installed at the locations as shown on the standard and/or as directed by the Engineer.

Basis of Payment: The work will not be paid for separately. For proposed culverts and/or storm sewer the cost of furnishing and installing the ties, including all required materials and labor, shall be included in the contract unit price of the concrete PIPE CULVERTS and/or concrete STORM SEWERS of the size and type specified.

MECHANICALLY STABILIZED EARTH RETAINING WALL

Description. This work shall consist of furnishing and constructing the Mechanically Stabilized Earth (MSE) retaining wall systems, as specified to the lines, grades and dimensions shown on the plans and as directed by the Engineer. This work also includes the preparation of design computations and shop drawings.

General. This work shall be done in accordance with the parts of Section 522 of the Standard Specifications that are applicable to MSE retaining wall construction.

Method of Measurement. This work shall be measured for payment in accordance with the Article 522.15 of Standard Specifications.

Basis of Payment. This work shall be paid for at the contract unit price per square foot for MECHANICALLY STABILIZED EARTH RETAINING WALL and applicable sections of Article 522.16.

ORNAMENTAL FENCE

Description. This work shall consist of furnishing and installing a steel fence, gates and accessories as shown on the plans.

Materials.

- A. The steel material for the fence framework (i.e., tubular pickets, rails and posts) shall meet the following:
 - I. Galvanized after forming:
 - a. Conform to the requirements of ASTM A1011/1011M
 - b. Minimum yield strength of 50,000 psi.
 - c. The exterior shall be hot-dip galvanized with a 0.45 oz/ft² minimum zinc weight.
 - d. The interior surface shall be coated with a minimum 81% normal zinc pigmented coating, 0.3 mils minimum thickness.
 - II. Galvanized prior forming
 - a. Conform to the requirements of ASTM A924/A924M
 - b. Minimum yield strength of 50,000 psi.
 - c. The steel shall be hot-dip galvanized to meet the requirements of ASTM A653/A653M with a minimum zinc coating weight of 0.90 oz/ft², Coating Designation G-90.
- B. The manufactured galvanized framework shall be subjected to a thermal stratification coating process (high-temperature, in-line, multi-stage, multi-layer) including as a minimum, a six-stage pretreatment/wash (with zinc phosphate), an electrostatic spray

application of an epoxy base, and a separate electrostatic spray application of a polyester finish. The base coat shall be a zinc-rich thermosetting epoxy powder coating (gray in color) with a minimum thickness of 2 mils. The topcoat shall be a “no-mar” TGIC polyester powder coat finish with a minimum thickness of 2 mils. The color shall be as specified on the standard drawing included in the plans. The stratification-coated framework shall be capable of meeting the performance requirements for each quality characteristic shown in the following table.

Quality Characteristics	ASTM Test Method	Performance Requirements
<i>Adhesion</i>	<i>D3359 – Method B</i>	<i>Adhesion (Retention of Coating) over 90% of test area (Tape and knife test).</i>
<i>Corrosion Resistance</i>	<i>B117 & D1654</i>	<i>Corrosion Resistance over 3,500 hours (Scribed per D1654; failure mode is accumulation of 1/8" coating loss from scribe or medium #8 blisters).</i>
<i>Impact Resistance</i>	<i>D2794</i>	<i>Impact Resistance over 60 inch lb. (Forward impact using 0.625" ball).</i>
<i>Weathering Resistance</i>	<i>D822, D2244, D523 (60° Method)</i>	<i>Weathering Resistance over 1,000 hours (Failure mode is 60% loss of gloss or color variance of more than 3 delta-E color units).</i>

Table 1 – Coating Performance Requirements

- C. The material for the fence pickets shall be 1” square x 16 gauge tubing. The cross-sectional shape of the rails shall conform to the manufacturer’s design with outside cross section dimensions of 1.75” square and a minimum thickness of 14 gauge. Picket holes in the horizontal rail shall be spaced 4.98” on center. The picket retaining rods shall be made of 0.125” diameter galvanized steel. The minimum post size shall be 2½” square x 12 gauge. High quality PVC grommets shall be supplied to seal all picket-to-rail intersections.

The manufacturer's literature (or shop drawings and specifications) shall be submitted to the Engineer prior to ordering the fence. The ornamental fence, as shown on LCDOT standards LC6600, LC6601 and LC6602, and as specified herein, is an industrial quality ornamental steel fence system. The Engineer is the sole judge of what is an equivalent substitution.

General: Installation of the fence shall be according to the applicable portions of Section 664 [Chain Link Fence] of the “Standard Specifications”, except as follows:

1. Dimensions and design details are as shown on the plans.
2. At some locations, the fencing shall be attached to concrete retaining walls. The attachment methods shall conform to the requirements of the “AASHTO LRFD (Load

and Resistance Factor Design) Bridge Design Specifications” (AASHTO 2007) Section 13, “Railings”. The allowable attachment methods include coring the concrete to 9” depth and grouting the fence posts in the holes or using mounting brackets and anchors.

3. Fence post installation in soil shall be done using concrete footings as shown on the plans.

Fence Fabrication:

- A. The pickets, rails and posts shall be pre-cut to specified lengths. The horizontal rails shall be pre-punched to accept the pickets.
- B. The grommets shall be inserted into the pre-punched holes in the rails and the pickets shall be inserted through the grommets so that the pre-drilled picket holes align with the internal upper raceway of the horizontal rails. (Note: This can best be accomplished by using an alignment template.) Retaining rods shall be inserted into each horizontal rail so that they pass through the predrilled holes in each picket completing the panel assembly.
- C. The completed panels shall be capable of supporting a 600lb load (applied at midspan) without any permanent deformation. Panels with rings shall be biasable to a 12.5% change in grade. Panels without rings shall be biasable to a 25% change in grade.
- D. Gates shall be fabricated using the same components as the fence system. The panel material and gate ends will have the same outside cross section dimensions as the horizontal rail. All rail and upright intersections shall be joined by welding. Picket and rail intersections shall be joined by welding or the same retaining rod used for the panel assembly.

Installation.

The fence posts shall be set according to the spacing shown in Table 2, ±½“, depending on the nominal span specified.

Span	6’ Nominal (67¾” Rail)				8’ Nominal (92⅝” Rail)			
Post Size	2½”	3”	2½”	3”	2½”	3”	2½”	3”
Bracket Type	Standard (BB301)		Angle (BB304)		Standard (BB301)		Angle (BB304)	
Post Settings ± ½” o.c.	71½”	72”	73”	73½”	96”	96½”	97½”	98”

Table 2 – Post Spacing Requirements

For installations that must be raked to follow sloping grades, the post spacing dimension must be measured along the grade. Fence panels shall be attached to posts with brackets supplied by the manufacturer. For fencing installed in soil, posts shall be set in concrete footings having a minimum depth of 36” as shown on the details included in the plans.

For fence installed on top of a concrete retaining wall, posts shall be set by methods such as plated posts or grouted core-drilled footings. The anchor method shall conform to the requirements of the "AASHTO LRFD (Load and Resistance Factor Design) Bridge Design Specifications" (AASHTO 2007), Section 13, "Railings". The Contractor shall provide shop drawings of the anchor method to the Engineer for review and approval.

FENCE INSTALLATION MAINTENANCE

When cutting/drilling rails or posts adhere to the following steps to seal the exposed surfaces:

- 1) Remove all metal shavings from cut area.
- 2) Apply custom finish paint matching fence color.

GATE INSTALLATION

Gate posts shall be spaced according to the manufacturers' gate drawings, dependent on standard out to out gate leaf dimensions and gate hardware selected. Type and quantity of gate hinges shall be based on the application; weight, height, and number of gate cycles. The manufacturers' gate drawings shall identify the necessary gate hardware required for the application. Gate hardware shall be provided by the manufacture of the gate and shall be installed per manufacturer's recommendations

Gate posts shall be spaced according to the gate openings specified in the construction plans. The fence panels shall be attached to the posts using mechanically fastened panel brackets supplied by the manufacturer.

Method of Measurement: Ornamental Fence will be measured for payment in feet along the top of the fence from center to center of the end posts.

Basis of Payment: This work will be paid for at the contract unit price per foot for ORNAMENTAL FENCE. The unit price shall include furnishing and installing the fence, including all fence connections, connection to a retaining wall (where required), concrete foundations, fence openings and gates (where indicated) and electric grounding. The unit price shall also include all equipment, materials and labor required to install the fence.

PAINT PAVEMENT MARKING – RAISED MEDIAN

Description. This work shall be done in accordance with Section 780 of the Standard Specifications and the details included in the plans.

Basis of Payment. This work will be paid for at the contract unit price per square foot for PAINT PAVEMENT MARKING – RAISED MEDIAN.

PERENNIAL PLANTS, ORNAMENTAL TYPE, GALLON POT;
PERENNIAL PLANTS, ORNAMENTAL TYPE, 3-GALLON POT;
PERENNIAL PLANTS, BULB TYPE

Description. This work shall consist of planting ornamental plants as shown on the plans or as directed by the Engineer.

General. This work shall be done in accordance with Section 254 of the Standard Specifications, except for except as herein modified.

The plants shall be installed at spacing as shown on the schedule and shall be a mixture of the following species:

<u>Symbol</u>	<u>Botanic Name</u>	<u>Common Name</u>	<u>Size</u>	<u>Spacing</u>
PA	Pennisetum alopecuroides	Fountain Grass	3 GAL	3 FT
RS	Perovskia atriplicifolia	Russian Sage	1 GAL	3 FT
AM	Achillea x 'Moonshine'	Moonshine Yarrow	1 GAL	1.5 FT
NF	Nepeta faassenii 'Walker's Low'	Walker's Low Catmint	1 GAL	1.5 FT
SB	Stachys bysantina 'Big Ears'	Big Ears Lambs Ears	1 GAL	1.5 FT
CV	Coreopsis verticillata 'Moonbeam'	Moonbeam 'Coreopsis'	1 GAL	1.5 FT
VS	Veronica 'Sunny Border Blue'	Sunny Border Blue Speedwell	1 GAL	1.5 FT
HH	Hemerocallis 'Happy Returns'	Happy Returns Daylily	1 GAL	1.5/1.0 FT
-	Narcissus 'Carlton'	Carlton Daffodil	1 BULB	3/FT*row

Method of Measurement. This work shall be measured for payment per units of plants installed, where one unit is equal to 100 pots or bulbs.

Basis of Payment. This work shall be paid for at the contract unit price per units of PERENNIAL PLANTS, ORNAMENTAL TYPE, of the size specified, and PERENNIAL PLANTS, BULB TYPE, which price shall include all labor, materials, and equipment required to complete the work.

PERIMETER EROSION BARRIER

Description: This work shall consist of constructing, maintaining, removing and disposing of perimeter erosion barrier as part of the project’s temporary erosion control system.

General: The work shall be performed according to Section 280 of the “Standard Specifications” and the following:

The perimeter erosion barrier shall be limited to temporary silt filter fence meeting the requirements of AASHTO Standard M 288-00. This specification is applicable to the use of a geotextile as a vertical, permeable interceptor designed to remove suspended soil from overland water flow. The function of a temporary silt fence is to filter and allow settlement of soil particles from sediment-laden water. The purpose is to prevent the eroded soil from being transported off the construction site by water runoff.

All removed materials shall be disposed of outside the right-of-way according to Article 202.03 of the “Standard Specifications”.

Materials:

Geotextile Requirements: The geotextile used for the temporary silt fence shall be classified as supported (with a wire or polymeric mesh backing) or unsupported (no backing). The temporary silt fence geotextile shall meet the requirements of Table 6 included below. All numeric values except Apparent Opening Size (AOS) represent Minimum Average Roll Values (MARV as defined in ASTM D4439). The values for AOS are the Maximum Average Roll Values.

Table 6 – Temporary Silt Fence Requirements

Requirements	Test Methods	Wire Backed Supported Silt Fence ^a	Unsupported Silt Fence	
			Geotextile Elongation $\geq 50\%$ ^b	Geotextile Elongation $< 50\%$ ^b
Maximum Post Spacing		4 feet	4 feet	6 feet
Grab Strength	ASTM D 4632			
Machine direction		90 lbs	124 lbs	124 lbs
X-Machine direction		90 lbs	100 lbs	100lbs
Permittivity ^c	ASTM D 4491	0.05 sec ⁻¹	0.05 sec ⁻¹	0.05 sec ⁻¹
Apparent Opening Size	ASTM D 4751	0.024in maximum average roll value		
Ultraviolet stability (retained strength)	ASTM D 4355	70% after 500 hours of exposure		

Notes:

- a) Silt fence support shall consist of 14-gauge steel wire with a mesh backing of 6” x 6” or prefabricated polymeric mesh of equivalent strength.
- b) As measured according to ASTM D 4632.
- c) These default filtration property values are based on empirical evidence with a variety of sediments. For environmentally sensitive areas, a review of previous experience and/or site or regionally specific geotextile tests should be performed by the agency to confirm suitability of these requirements.

Support Posts: The support posts may be composed of wood, steel or a synthetic material. The posts shall be a minimum length of 3 feet plus the buried depth. They shall have sufficient strength to resist damage during installation and to the support the applied loads due to material build up behind the silt fence.

- 1) Hardwood posts shall be a minimum of 1.2” x 1.2”

- 2) No. 2 southern pine posts shall be a minimum of 2.6" x 2.6"
- 3) Steel posts may be U, T, L, or C shape, weighing 1.3 lbs per foot.

Fence Support: The wire or polymer support fence shall be at least 30" high and strong enough to support the applied loads. Polymer support fences shall meet the same ultraviolet degradation requirements as the geotextile material (see table 6).

The wire support fence shall:

- Be a minimum of 14-gauge.
- Have a minimum of six horizontal wires.
- The maximum vertical wire spacing shall be 6".

Construction:

The silt fence shall be installed with a minimum height above ground of 30". The geotextile at the bottom of the fence shall be buried, in a "J" configuration to a minimum depth of 6", in a trench so that no flow can pass under the silt fence. The trench shall be backfilled and the soil compacted over the geotextile.

The geotextile shall be spliced together with a sewn seam or two sections of fence may be overlapped instead. The sewn seam shall be positioned only at a support post.

The Contractor must demonstrate to the satisfaction of the Engineer that the geotextile can withstand the anticipated sediment loading.

The posts shall be placed at the spacing shown on the project plans. The posts shall be driven or placed a minimum of 20" into the ground. The depth shall be increased to 24" if the fence is placed on a slope of 3:1 or greater. If the 20" depth is impossible to obtain, the posts shall be adequately secured to prevent overturning of the fence due to sediment loading.

The support fence shall be securely fastened to the upslope side of the fence post. The support fence shall extend from the ground surface to the top of the geotextile.

When un-supported fence is used, the geotextile shall be securely fastened to the fence posts.

Field monitoring shall be performed to verify that the placement of an armor system does not damage the geotextile.

Silt fences should be continuous and transverse to the flow. The silt fence should follow the contours of the site as closely as possible. The fence shall also be placed such that run off cannot flow around the end(s) of the fence.

The silt fence should be located so that the drainage area is limited to an area equivalent to 1000 square feet for each 10 feet of fence length. Caution should be used where the site slope is

greater than 1:1, and/or water flow rates exceed 0.1 cubic feet per second for each 10 feet of fence length.

Maintenance:

The Contractor shall inspect all temporary silt fences immediately after each rainfall and at least daily during prolonged rainfall. The Contractor shall immediately correct any deficiencies.

The Contractor shall also make a daily review of the location of silt fences in areas where construction activities have altered the natural contour and drainage runoff to ensure that the silt fences area properly located for effectiveness. Where deficiencies exist as determined by the Engineer, additional silt fence shall be installed as directed by the Engineer.

Damaged or otherwise ineffective silt fences shall be repaired or replaced promptly.

Sediment deposits shall either be removed when the deposit reaches half the height of the fence or a second silt fence shall be installed as directed by the Engineer.

The silt fence shall remain in place until the Engineer directs it to be removed. After the fence removal, the Contractor shall remove and dispose of any excess sediment accumulations, dress the area to give it a pleasing appearance, and cover with vegetation all bare areas according to the contract requirements.

The removed silt fence may be used at other locations provided the geotextile and other material requirements continue to be met to the satisfaction of the Engineer.

During the construction operation when any loose material is deposited in the flow line of ditches, gutters or drainage structures so the natural flow of water is obstructed, the material shall be removed at the close of each working day.

At the conclusion of the construction operations all drainage structures shall be free from all dirt and debris. This work will not be paid for separately but shall be considered included in the unit cost of PERIMETER EROSION BARRIER.

Method of Measurement: This work will be measured for payment in place in feet.

Basis of Payment: This work will be paid for at the contract unit price per foot for PERIMETER EROSION BARRIER. The unit price shall include all work and materials necessary to properly install the perimeter erosion barrier, maintain the perimeter erosion barrier throughout the project, and to remove and dispose of the used materials at the completion of the project.

PIPE DRAINS

Description. This work shall consist of constructing pipe drains of the required inside diameter.

Materials. The pipe drain materials shall meet the requirements of Article 601.02(a) of the “Standard Specifications” except that:

The pipes shall be limited to:

- (5) Polyvinyl Chloride (PVC) pipe [1040.03(a)]
- (6) Corrugated Polyvinyl Chloride (PVC) pipe with a smooth interior [1040.03(d)]
- (8) Corrugated Polyethylene (PE) Pipe with a Smooth Interior [1040.04(a)]

General. The work shall be performed according to Section 601 of the “Standard Specifications” and the following:

The work shall include constructing pipe drains to replace and/or relocate existing drainage lines (field tiles, sump pump outlets, etc...) encountered during construction.

The work shall also include providing a drainage outlet for traffic signal and/or interconnect handholes when in the opinion of the Engineer the additional drainage is required. The handhole drainage pipe shall extend from the handhole and outlet in a drainage ditch or drainage structure.

Pipe drains emptying into a drainage ditch shall be fitted with a concrete collar as shown on Lake County Division of Transportation standard LC6020 (section A-A). The rodent shields shown on LC6020 shall also be included.

Pipe drain connections to handholes and/or drainage structures shall be made as on Lake County Division of Transportation standard LC6020 (Detail C).

Method of Measurement. Contingency quantities of 4” and 6” pipe drain have been included in this contract so that if drainage lines are encountered, and/or handhole drainage is required by the Engineer, a unit price will have been established for this work. Pipe drains shall be measured in place, in feet, of actual pipe installed.

Basis of Payment. This work will be paid for at the contract unit price per foot for PIPE DRAINS of the size specified. Payment will be based on the actual length of pipe installed without a change in unit price because of adjustment in plan quantities, and no extra compensation will be allowed for any delays, inconveniences or damage sustained by the Contractor in performing the work. The unit price shall include all materials, equipment and labor required to install the pipe drains, including concrete collars and rodent shields for ditch/side slope outlets; and drilling and grouting for connections to culverts, drainage structures and/or handholes.

PIPE UNDERDRAINS, TYPE 1, 4”

Description. This work shall consist of constructing pipe underdrains.

Materials. The pipe underdrain materials shall meet the requirements of Article 601.02(b) of the “Standard Specifications” except that:

The pipe shall be limited to:

- (2) Perforated Polyvinyl Chloride (PVC) Pipe [1040.03(b)]
- (3) Perforated Corrugated Polyvinyl Chloride (PVC) Pipe with a Smooth Interior [1040.03(c)]
- (5) Perforated Corrugated Polyethylene (PE) Pipe with a Smooth Interior [1040.04(a)]

General. The work shall be performed according to Section 601 of the “Standard Specifications” and the following:

Rodent shields and square concrete collars (where required) as shown on LCDOT standard drawing LC6020, shall be included in PIPE UNDERDRAINS, TYPE 1, 4”.

Method of Measurement. Pipe underdrains shall be measured in place, in feet, of actual pipe installed.

Basis of Payment. This work will be paid for at the contract unit price per foot for PIPE UNDERDRAINS, TYPE 1, 4”. The unit price shall include furnishing and placing all pipe, fittings, connecting pipes, rodent shields, bedding and concrete collars. The unit price shall also include all equipment, materials and labor required to furnish and construct the pipe underdrains.

POROUS GRANULAR EMBANKMENT, SPECIAL

Description. This work shall consist of furnishing, and placing porous granular embankment (special) material as detailed on the plans, according to Section 207 except as modified herein.

Materials. The gradation of the porous granular material may be any of the following CA 6 thru CA 11 according to Article 1004.

Basis of Payment. This work will be paid for at the contract unit price per Cubic Yard (Cubic Meter) for POROUS GRANULAR EMBANKMENT, SPECIAL.

PRECONSTRUCTION VIDEO TAPING

Description. This work shall consist of videotaping the project site prior to commencing construction activities in order to provide a basis to determine whether visible damage occurred during construction.

General. The work shall include videotaping on all streets within the project limits. The videotaping shall encompass the entire area between the right-of-way lines. Prior to videotaping the Contractor shall coordinate with the Engineer to insure that any areas of special emphasis are noted and sufficiently covered during the videotaping process.

The videotaping shall consist of a minimum of two passes. The videotaping shall be performed at a traversing speed not to exceed 50 feet per minute.

The recording shall include an audio track. The accompanying narrative shall note the condition of existing facilities and project site objects. The narrative shall also include address information.

The Contractor shall provide one copy of the recording in DVD format to the Engineer. The recording shall be of suitable photographic clarity to serve as a basis for establishing whether visible damage occurred during construction. The Contractor may not begin construction activities until the Engineer has approved the recording.

Basis of Payment. This work will be paid for at the contract lump sum price for PRECONSTRUCTION VIDEO TAPING. The contract lump sum price shall be payment in full for all materials, labor and equipment required to perform the videotaping as described herein.

PROTECTIVE COAT

Description. This work shall consist of applying a protective coat to exposed concrete surfaces.

Materials. The protective coat shall meet the requirements of Article 1023.01 of the “Standard Specifications”.

General. The work shall be performed according to Article 420.18 of the “Standard Specifications” except that:

The protective coat shall be applied to the exposed surfaces of all concrete pavements and appurtenances regardless of the calendar date limitations contained in the first paragraph of Article 420.18 of the “Standard Specifications”.

Portland cement concrete curing shall be limited to methods specified in Article 1020.13 (a) [1], [2] and [3].

Method of Measurement. The exposed surfaces of all concrete pavements and appurtenances will be measured in place and the area computed in square yards.

Basis of Payment. This work will be paid for at the contract unit price per square yard for PROTECTIVE COAT. The unit price shall include all materials, equipment and labor required for two applications of protective coat to exposed surfaces of concrete pavements and appurtenances. The unit price shall include both applications with no additional compensation for the second coat.

RECESSED REFLECTIVE PAVEMENT MARKER

Description. This work shall consist of furnishing and setting reflective pavement markers in a recessed groove in the pavement. The recessed pavement markers shall be used to supplement other pavement markings, similar to the use of Raised Reflective Pavement Markers.

Materials. The reflective pavement marker lens shall be a 3M 190 series pavement marker. The reflector holder shall be a MarkerOne Series R100 reflector holder. The epoxy used shall be as recommended by the pavement marker manufacturer.

Installation. The spacing and orientation of the pavement markers shall be as shown on the plans and/or as directed by the Engineer.

A recessed groove shall be cut in the pavement 5.25" wide and 1.0" deep on a 15.5" diameter. A 3.5' long groove shall taper from 0" (normal pavement) to 0.35" depth (full-recessed) before and after the groove. For additional detail see the LCDOT standard LC7805.

The recessed area shall be cleaned free of all loose material, and be dry before the placement of the pavement marker. All excess material resulting from the construction of the recessed area shall be completely removed from the surface of the roadway by means of a vacuum sweeper truck. The pavement marker shall be cemented with epoxy in the center of the 1.0" deep recessed groove.

Inspection. The recessed reflective pavement marker shall be inspected following installation, but no later than November 30 of the year installed. Following a winter performance period (December 1 – May 31), a final inspection will be made and corrective action (if required) taken according to the requirements of Article 781.04 of the "Standard Specifications". During the inspection a straight edge shall be placed across the recess to check that the top of the marker is below the pavement.

Basis of Payment. This work will be paid for at the contract unit price each for RECESSED REFLECTIVE PAVEMENT MARKER. Payment shall be made according to the inspection and bonding requirements in Article 781.04 of the "Standard Specifications". The unit price shall

include all costs for cutting the grooves into the pavement. The unit price shall also include all equipment, materials and labor required to install the recessed reflective pavement markers.

RECESSED REFLECTIVE PAVEMENT MARKER REMOVAL

Description. This work shall consist of the removal of existing recessed reflective pavement markers or their reflectors where they are in conflict with the construction staging traffic patterns.

General. This work shall be performed in accordance with the Section 783 of Standard Specifications.

Where required to be removed outside of the reconstruction or resurfacing limits, only the reflectors shall be removed and the removal of pavement markers shall not be permitted. Reflector removal and replacement shall be paid for as REPLACEMENT REFLECTOR and if new reflectors are provided they should be in accordance with the special provision for RECESSED REFLECTIVE PAVEMENT MARKER included herein.

Basis of Payment. This work shall be paid for at the contract unit price per each for RECESSED REFLECTIVE PAVEMENT MARKER REMOVAL, which price shall include all labor, materials, and equipment required to complete the work.

REMOVAL AND DISPOSAL OF REGULATED SUBSTANCES

Description. This work shall consist of the removal and disposal of regulated substances according to Section 669 of the Standard Specifications as revised below.

Contract Specific Sites. The excavated soil and groundwater within the areas listed below shall be managed as either “uncontaminated soil”, hazardous waste, special waste or non-special waste. For stationing, the lateral distance is measured from centerline and the farthest distance is the offset distance or construction limit, whichever is less.

Site #1: Aptakisic Road at Wisconsin Central Limited (subsidiary of the Canadian National Railway) railroad at-grade crossing east of Weiland Road intersection

- Station 112+86 65’ LT and 113+34 60’ RT to Station 113+92 65’ LT and 114+41 60’ RT (Railroad ROW). Soil from the railroad ROW was not assessed during the PSI, therefore it will require analytical testing for CCDD characterization, disposal at an appropriate landfill, or should remain onsite within the property it originated in.

Revise Section 669 of the Standard Specifications to read:

“SECTION 669. REMOVAL AND DISPOSAL OF REGULATED SUBSTANCES

669.01 Description. This work shall consist of the transportation and proper disposal of contaminated soil and groundwater. This work shall also consist of the removal, transportation, and proper disposal of underground storage tanks (UST), their content and associated underground piping to the point where the piping is above the ground, including determining the content types and estimated quantities.

669.02 Equipment. The Contractor shall notify the Engineer of the delivery of all excavation, storage, and transportation equipment to a work area location. The equipment shall comply with OSHA and American Petroleum Institute (API) guidelines and shall be furnished in a clean condition. Clean condition means the equipment does not contain any residual material classified as a non-special waste, non-hazardous special waste, or hazardous waste. Residual materials include, but are not limited to, petroleum products, chemical products, sludges, or any other material present in or on equipment.

Before beginning any associated soil or groundwater management activity, the Contractor shall provide the Engineer with the opportunity to visually inspect and approve the equipment. If the equipment contains any contaminated residual material, decontamination shall be performed on the equipment as appropriate to the regulated substance and degree of contamination present according to OSHA and API guidelines. All cleaning fluids used shall be treated as the contaminant unless laboratory testing proves otherwise.

669.03 Pre-construction Submittals. Prior to beginning this work, or working in areas with regulated substances, the Contractor shall submit a Regulated Substance Pre-Construction Plan (RSPCP) to the Engineer for review and approval using form BDE 2730. The form shall be signed by an Illinois licensed Professional Engineer or Professional Geologist.

As part of the RSPCP, the qualifications of Contractor(s) or firm(s) performing the following work shall be listed.

- (a) On-Site Monitoring. Qualification for on-site monitoring of regulated substance work and on-site monitoring of UST removal requires either pre-qualification in Hazardous Waste by the Department or demonstration of acceptable project experience in remediation and special waste operations for contaminated sites in accordance with applicable Federal, State, or local regulatory requirements.

Qualification for each individual performing on-site monitoring requires a minimum of one-year of experience in similar activities as those required for the project.

- (b) Underground Storage Tank. Qualification for underground storage tank (UST) work requires licensing and certification with the Office of the State Fire Marshall (OSFM) and possession of all permits required to perform the work. A copy of the permit shall be provided to the Engineer prior to tank removal.

The qualified Contractor(s) or firm(s) shall also document it does not have any current or former ties with any of the properties contained within, adjoining, or potentially affecting the work.

The Engineer will require up to 30 calendar days for review of the RSPCP. The review may involve rejection or revision and resubmittal; in which case, an additional 30 days will be required for each subsequent review. Work shall not commence until the RSPCP has been approved by the Engineer. After approval, the RSPCP shall be revised as necessary to reflect changed conditions in the field.

CONSTRUCTION REQUIREMENTS

669.04 Contaminated Soil and/or Groundwater Monitoring. Prior to beginning excavation, the Contractor shall mark the limits of removal for approval by the Engineer. Once excavation begins, the work and work area involving regulated substances shall be monitored by qualified personnel. The qualified personnel shall be on-site continuously during excavation and loading of material containing regulated substances. The qualified personnel shall be equipped with either a photoionization detector (PID) (minimum 10.6eV lamp), or a flame ionization detector (FID), and other equipment, as appropriate, to monitor for potential contaminants associated with volatile organic compounds (VOCs) or semi-volatile organic compounds (SVOCs). The PID or FID meter shall be calibrated on-site and background level readings taken and recorded daily, and as field and weather conditions change. Any field screen reading on the PID or FID in excess of background levels indicates the potential presence of contaminated material requiring handling as a non-special waste, special waste, or hazardous waste. PID or FID readings may be used as the basis of increasing the limits of removal with the approval of the Engineer but shall in no case be used to decrease the limits.

The qualified personnel shall document field activities using form BDE 2732 (Regulated Substances Monitoring Daily Record) including the name(s) of personnel conducting the monitoring, weather conditions, PID or FID calibration records, a list of equipment used on-site, a narrative of activities completed, photo log sheets, manifests and landfill tickets, monitoring results, how regulated substances were managed and other pertinent information.

Samples will be collected in accordance with the RSPCP. Samples shall be analyzed for the contaminants of concern (COCs), including pH, based on the property's land use history, the encountered abnormality and/or the parameters listed in the maximum allowable concentration (MAC) for chemical constituents in uncontaminated soil established pursuant to Subpart F of 35 Ill. Adm. Code 1100.605. The analytical results shall serve to document the level of contamination.

Samples shall be grab samples (not combined with other locations). The samples shall be taken with decontaminated or disposable instruments. The samples shall be placed in sealed containers and transported in an insulated container to the laboratory. The container shall

maintain a temperature of 39 °F (4 °C). All samples shall be clearly labeled. The labels shall indicate the sample number, date sampled, collection location and depth, and any other relevant observations.

The laboratory shall use analytical methods which are able to meet the lowest appropriate practical quantitation limits (PQL) or estimated quantitation limit (EQL) specified in "Test Methods for Evaluating Solid Wastes, Physical/Chemical Methods", EPA Publication No. SW-846; "Methods for the Determination of Organic Compounds in Drinking Water", EPA, EMSL, EPA-600/4-88/039; and "Methods for the Determination of Organic Compounds in Drinking Water, Supplement III", EPA 600/R-95/131, August 1995. For parameters where the specified cleanup objective is below the acceptable detection limit (ADL), the ADL shall serve as the cleanup objective. For other parameters the ADL shall be equal to or below the specified cleanup objective.

669.05 Contaminated Soil and/or Groundwater Management and Disposal. The management and disposal of contaminated soil and/or groundwater shall be according to the following:

- (a) Soil Analytical Results Exceed Most Stringent MAC. When the soil analytical results indicate that detected levels exceed the most stringent maximum allowable concentration (MAC) for chemical constituents in uncontaminated soil established pursuant to Subpart F of 35 Illinois Administrative Code 1100.605, the soil shall be managed as follows:
 - (1) When analytical results indicate inorganic chemical constituents exceed the most stringent MAC but they are still considered within area background levels by the Engineer, the excavated soil can be utilized within the construction limits as fill, when suitable. If the soils cannot be utilized within the construction limits, they shall be managed and disposed of off-site as a non-special waste, special waste, or hazardous waste as applicable.
 - (2) When analytical results indicate chemical constituents exceed the most stringent MAC but do not exceed the MAC for a Metropolitan Statistical Area (MSA) County, the excavated soil can be utilized within the construction limits as fill, when suitable, or managed and disposed of off-site as "uncontaminated soil" at a clean construction and demolition debris (CCDD) facility or an uncontaminated soil fill operation (USFO) within an MSA County provided the pH of the soil is within the range of 6.25 - 9.0, inclusive.
 - (3) When analytical results indicate chemical constituents exceed the most stringent MAC but do not exceed the MAC for an MSA County excluding Chicago, or the MAC within the Chicago corporate limits, the excavated soil can be utilized within the construction limits as fill, when suitable, or managed and disposed of off-site as "uncontaminated soil" at a CCDD facility or an USFO within an MSA County excluding Chicago or within the Chicago corporate limits provided the pH of the soil is within the range of 6.25 - 9.0, inclusive.

- (4) When analytical results indicate chemical constituents exceed the most stringent MAC but do not exceed the MAC for an MSA County excluding Chicago, the excavated soil can be utilized within the construction limits as fill, when suitable, or managed and disposed of off-site as “uncontaminated soil” at a CCDD facility or an USFO within an MSA County excluding Chicago provided the pH of the soil is within the range of 6.25 - 9.0, inclusive.
 - (5) When the Engineer determines soil cannot be managed according to Articles 669.05(a)(1) through (a)(4) above, the soil shall be managed and disposed of off-site as a non-special waste, special waste, or hazardous waste as applicable.
- (b) Soil Analytical Results Do Not Exceed Most Stringent MAC. When the soil analytical results indicate that detected levels do not exceed the most stringent MAC, the excavated soil can be utilized within the construction limits or managed and disposed off-site as “uncontaminated soil” according to Article 202.03. However, the excavated soil cannot be taken to a CCDD facility or an USFO for any of the following reasons.
- (1) The pH of the soil is less than 6.25 or greater than 9.0.
 - (2) The soil exhibited PID or FID readings in excess of background levels.
- (c) Soil Analytical Results Exceed Most Stringent MAC but Do Not Exceed Tiered Approach to Corrective Action Objectives (TACO) Residential. When the soil analytical results indicate that detected levels exceed the most stringent MAC but do not exceed TACO Tier 1 Soil Remediation Objectives for Residential Properties pursuant to 35 IAC 742 Appendix B Table A, the excavated soil can be utilized within the right-of-way or managed and disposed off-site as “uncontaminated soil” according to Article 202.03. However, the excavated soil cannot be taken to a CCDD facility or an USFO.
- (d) Groundwater. When groundwater analytical results indicate the detected levels are above Appendix B, Table E of 35 Illinois Administrative Code 742, the most stringent Tier 1 Groundwater Remediation Objectives for Groundwater Component of the Groundwater Ingestion Route for Class 1 groundwater, the groundwater shall be managed off-site as a special waste. The groundwater shall be containerized and trucked to an off-site treatment facility or may be discharged to a sanitary sewer or combined sewer when permitted by the local sewer authority. Groundwater discharged to a sewer shall be pre-treated to remove particulates and measured with a calibrated flow meter to comply with applicable discharge limits. A copy of the permit shall be provided to the Engineer prior to discharging groundwater to the sewer.

All groundwater encountered within trenches may be managed within the trench and allowed to infiltrate back into the ground. If the groundwater cannot be managed within the trench it must be removed as a special or hazardous waste. The Contractor is prohibited from managing groundwater within the trench by discharging it through any

existing or new storm sewer. The Contractor shall install backfill plugs within the area of groundwater contamination.

One backfill plug shall be placed down gradient to the area of groundwater contamination. Backfill plugs shall be installed at intervals not to exceed 50 ft (15 m). Backfill plugs are to be 4 ft (1.2 m) long, measured parallel to the trench, full trench width and depth. Backfill plugs shall not have any fine aggregate bedding or backfill, but shall be entirely cohesive soil or any class of concrete. The Contractor shall provide test data that the material has a permeability of less than 10^{-7} cm/sec according to ASTM D 5084, Method A or per another test method approved by the Engineer.

The Contractor shall use due care when transferring contaminated material from the area of origin to the transporter. Should releases of contaminated material to the environment occur (i.e., spillage onto the ground, etc.), the Contractor shall clean-up spilled material and place in the appropriate storage containers as previously specified. Clean-up shall include, but not be limited to, sampling beneath the material staging area to determine complete removal of the spilled material.

The Contractor shall be responsible for transporting and disposing all material classified as a non-special waste, special waste, or hazardous waste from the job site to an appropriately permitted landfill facility. The transporter and the vehicles used for transportation shall comply with all federal, state, and local rules and regulations governing the transportation of non-special waste, special waste, or hazardous waste.

All equipment used by the Contractor to haul contaminated material to the landfill facility shall be lined with a 6 mil (150 micron) polyethylene liner and securely covered during transportation. The Contractor shall obtain all documentation including any permits and/or licenses required to transport the contaminated material to the disposal facility.

The Contractor shall provide engineered barriers, when required, and shall include materials sufficient to completely line excavation surfaces, including sloped surfaces, bottoms, and sidewall faces, within the areas designated for protection.

The Engineer shall coordinate with the Contractor on the completion of all documentation. The Contractor shall make all arrangements for collection and analysis of landfill acceptance testing. The Contractor shall coordinate for waste disposal approval with the disposal facility. After the Contractor completes these activities and upon receipt of authorization from the Engineer, the Contractor shall initiate the disposal process.

The Contractor shall provide the Engineer with all transport-related documentation within two days of transport or receipt of said document(s). The Engineer shall maintain the file for all such documentation. For management of special or hazardous waste, the Contractor shall provide the Engineer with documentation the Contractor (or subcontractor, if a subcontractor is used for transportation) is operating with a valid Illinois special waste transporter permit at least two weeks before transporting the first load of contaminated material.

The Contractor shall schedule and arrange the transport and disposal of each load of contaminated material produced. The Contractor shall make all transport and disposal arrangements so no contaminated material remains within the project area at the close of business each day. Exceptions to this specification require prior approval from the Engineer within 24 hours of close of business. The Contractor shall be responsible for all other pre-disposal/transport preparations necessary daily to accomplish management activities.

Any waste generated as a special or hazardous waste from a non-fixed facility shall be manifested off-site using the Department's county generator number. An authorized representative of the Department shall sign all manifests for the disposal of the contaminated material and confirm the Contractor's transported volume. Any waste generated as a non-special waste may be managed off-site without a manifest, a special waste transporter, or a generator number.

The Contractor shall select a landfill mandated by definition of the contaminant within the State of Illinois. The Department will review and approve or reject the facility proposed by the Contractor to use as a landfill. The Contractor shall verify whether the selected disposal facility is compliant with those applicable standards as mandated by definition of the contaminant and whether the disposal facility is presently, has previously been, or has never been, on the United States Environmental Protection Agency (U.S. EPA) National Priorities List or the Resource Conservation and Recovery Act (RCRA) List of Violating Facilities. The Contractor shall be responsible for coordinating permits with the IEPA. The use of a Contractor selected landfill shall in no manner delay the construction schedule or alter the Contractor's responsibilities as set forth.

669.06 Non-Special Waste Certification. An authorized representative of the Department shall sign and date all non-special waste certifications. The Contractor shall be responsible for providing the Engineer with the required information that will allow the Engineer to certify the waste is not a special waste.

- (a) Definition. A waste is considered a non-special waste as long as it is not:
- (1) a potentially infectious medical waste;
 - (2) a hazardous waste as defined in 35 IAC 721;
 - (3) an industrial process waste or pollution control waste that contains liquids, as determined using the paint filter test set forth in subdivision (3)(A) of subsection (m) of 35 IAC 811.107;
 - (4) a regulated asbestos-containing waste material, as defined under the National Emission Standards for Hazardous Air Pollutants in 40 CFR 61.141;

- (5) a material containing polychlorinated biphenyls (PCB's) regulated pursuant to 40 CFR Part 761;
 - (6) a material subject to the waste analysis and recordkeeping requirements of 35 IAC 728.107 under land disposal restrictions of 35 IAC 728;
 - (7) a waste material generated by processing recyclable metals by shredding and required to be managed as a special waste under Section 22.29 of the Environmental Protection Act; or
 - (8) an empty portable device or container in which a special or hazardous waste has been stored, transported, treated, disposed of, or otherwise handled.
- (b) Certification Information. All information used to determine the waste is not a special waste shall be attached to the certification. The information shall include but not be limited to:
- (1) the means by which the generator has determined the waste is not a hazardous waste;
 - (2) the means by which the generator has determined the waste is not a liquid;
 - (3) if the waste undergoes testing, the analytic results obtained from testing, signed and dated by the person responsible for completing the analysis;
 - (4) if the waste does not undergo testing, an explanation as to why no testing is needed;
 - (5) a description of the process generating the waste; and
 - (6) relevant material safety data sheets.

669.07 Temporary Staging. The Contractor shall excavate and dispose of all waste material as mandated by the contaminants without temporary staging. If circumstances require temporary staging, he/she shall request in writing, approval from the Engineer.

When approved, the Contractor shall prepare a secure location within the project area capable of housing containerized waste materials. The Contractor shall contain all waste material in leak-proof storage containers such as lined roll-off boxes or 55 gal (208 L) drums, or stored in bulk fashion on storage pads. The design and construction of such storage pad(s) for bulk materials shall be subject to approval by the Engineer. The Contractor shall place the staged storage containers on an all-weather gravel-packed, asphalt, or concrete surface. The Contractor shall maintain a clearance both above and beside the storage units to provide maneuverability during loading and unloading. The Contractor shall provide any assistance or equipment requested by the Engineer for authorized personnel to inspect and/or sample contents of each storage container. All containers and their contents shall remain intact and undisturbed by unauthorized persons until the manner of disposal is determined. The Contractor shall keep the

storage containers covered, except when access is requested by authorized personnel of the Department. The Engineer shall authorize any additional material added to the contents of any storage container before being filled.

The Contractor shall ensure the staging area is enclosed (by a fence or other structure) to ensure direct access to the area is restricted, and he/she shall procure and place all required regulatory identification signs applicable to an area containing the waste material. The Contractor shall be responsible for all activities associated with the storage containers including, but not limited to, the procurement, transport, and labeling of the containers. The Contractor shall clearly mark all containers in permanent marker or paint with the date of waste generation, location and/or area of waste generation, and type of waste (e.g., decontamination water, contaminated clothing, etc.). The Contractor shall place these identifying markings on an exterior side surface of the container. The Contractor shall separately containerize each contaminated medium, i.e. contaminated clothing is placed in a separate container from decontamination water. Containers used to store liquids shall not be filled in excess of 80 percent of the rated capacity. The Contractor shall not use a storage container if visual inspection of the container reveals the presence of free liquids or other substances that could classify the material as a hazardous waste in the container.

The Department will not be responsible for any additional costs incurred, if mismanagement of the staging area, storage containers, or their contents by the Contractor results in excess cost expenditure for disposal or other material management requirements.

669.08 Underground Storage Tank Removal. For the purposes of this section, an underground storage tank (UST) includes the underground storage tank, piping, electrical controls, pump island, vent pipes and appurtenances.

Prior to removing an UST, the Engineer shall determine whether the Department is considered an "owner" or "operator" of the UST as defined by the UST regulations (41 Ill. Adm. Code Part 176). Ownership of the UST refers to the Department's owning title to the UST during storage, use or dispensing of regulated substances. The Department may be considered an "operator" of the UST if it has control of, or has responsibility for, the daily operation of the UST. The Department may however voluntarily undertake actions to remove an UST from the ground without being deemed an "operator" of the UST.

In the event the Department is deemed not to be the "owner" or "operator" of the UST, the OSFM removal permit shall reflect who was the past "owner" or "operator" of the UST. If the "owner" or "operator" cannot be determined from past UST registration documents from OSFM, then the OSFM removal permit will state the "owner" or "operator" of the UST is the Department. The Department's Office of Chief Counsel (OCC) will review all UST removal permits prior to submitting any removal permit to the OSFM. If the Department is not the "owner" or "operator" of the UST then it will not register the UST or pay any registration fee.

The Contractor shall be responsible for obtaining all permits required for removing the UST, notification to the OSFM, using an OSFM certified tank contractor, removal and disposal of the

UST and its contents, and preparation and submittal of the OSFM Site Assessment Report in accordance with 41 Ill. Adm. Code Part 176.330.

The Contractor shall contact the Engineer and the OSFM's office at least 72 hours prior to removal to confirm the OSFM inspector's presence during the UST removal. Removal, transport, and disposal of the UST shall be according to the applicable portions of the latest revision of the "American Petroleum Institute (API) Recommended Practice 1604".

The Contractor shall collect and analyze tank content (sludge) for disposal purposes. The Contractor shall remove as much of the regulated substance from the UST system as necessary to prevent further release into the environment. All contents within the tank shall be removed, transported and disposed of, or recycled. The tank shall be removed and rendered empty according to IEPA definition.

The Contractor shall collect soil samples from the bottom and sidewalls of the excavated area in accordance with 35 Ill. Adm. Code Part 734.210(h) after the required backfill has been removed during the initial response action, to determine the level of contamination remaining in the ground, regardless if a release is confirmed or not by the OSFM on-site inspector.

In the event the UST is designated a leaking underground storage tank (LUST) by the OSFM's inspector, or confirmation by analytical results, the Contractor shall notify the Engineer and the DESU. Upon confirmation of a release of contaminants from the UST and notifications to the Engineer and DESU, the Contractor shall report the release to the Illinois Emergency Management Agency (IEMA) (e.g., by telephone or electronic mail) and provide them with whatever information is available ("owner" or "operator" shall be stated as the past registered "owner" or "operator", or the IDOT District in which the UST is located and the DESU Manager);

The Contractor shall perform the following initial response actions if a release is indicated by the OSFM inspector:

- (a) Take immediate action to prevent any further release of the regulated substance to the environment, which may include removing, at the Engineer's discretion, and disposing of up to 4 ft (1.2 m) of the contaminated material, as measured from the outside dimension of the tank
- (b) Identify and mitigate fire, explosion and vapor hazards;
- (c) Visually inspect any above ground releases or exposed below ground releases and prevent further migration of the released substance into surrounding soils and groundwater; and
- (d) Continue to monitor and mitigate any additional fire and safety hazards posed by vapors and free product that have migrated from the UST excavation zone and entered into subsurface structures (such as sewers or basements).

The UST excavation shall be backfilled according to applicable portions of Sections 205, 208, and 550 with a material that will compact and develop stability. The material shall be approved prior to placement. All uncontaminated concrete and soil removed during tank extraction may be used to backfill the excavation, at the discretion of the Engineer.

After backfilling the excavation, the site shall be graded and cleaned.

669.09 Regulated Substance Final Construction Report. Not later than 90 days after completing this work, the Contractor shall submit a Regulated Substance Final Construction Report (RSFCR) to the Engineer using form BDE 2733 and required attachments. The form shall be signed by an Illinois licensed Professional Engineer or Professional Geologist.

669.10 Method of Measurement. Non-special waste, special waste, and hazardous waste soil will be measured for payment according to Article 202.07(b) when performing earth excavation, Article 502.12(b) when excavating for structures, or by computing the volume of the trench using the maximum trench width permitted and the actual depth of the trench.

Groundwater containerized and transported off-site for management, storage, and disposal will be measured for payment in gallons (liters).

Backfill plugs will be measured in cubic yards (cubic meters) in place, except the quantity for which payment will be made shall not exceed the volume of the trench, as computed by using the maximum width of trench permitted by the Specifications and the actual depth of the trench, with a deduction for the volume of the pipe.

Engineered Barriers will be measured for payment in square yards (square meters).

669.11 Basis of Payment. The work of preparing, submitting and administering a Regulated Substances Pre-Construction Plan will be paid for at the contract lump sum price for REGULATED SUBSTANCES PRE-CONSTRUCTION PLAN.

On-site monitoring of regulated substances, including completion of form BDE 2732 for each day of work, will be paid for at the contract unit price per calendar day, or fraction thereof, for
ON-SITE MONITORING OF REGULATED SUBSTANCES.

The installation of engineered barriers will be paid for at the contract unit price per square yard (square meter) for ENGINEERED BARRIER.

The work of removing a UST, soil excavation, soil and content sampling, and the excavated soil, UST content, and UST disposal will be paid for at the contract unit price per each for UNDERGROUND STORAGE TANK REMOVAL.

The transportation and disposal of soil and other materials from an excavation determined to be contaminated will be paid for at the contract unit price per cubic yard (cubic meter) for NON-SPECIAL WASTE DISPOSAL, SPECIAL WASTE DISPOSAL, or HAZARDOUS WASTE DISPOSAL.

The transportation and disposal of groundwater from an excavation determined to be contaminated will be paid for at the contract unit price per gallon (liter) for SPECIAL WASTE GROUNDWATER DISPOSAL or HAZARDOUS WASTE GROUNDWATER DISPOSAL. When groundwater is discharged to a sanitary or combined sewer by permit, the cost will be paid for according to Article 109.05.

Backfill plugs will be paid for at the contract unit price per cubic yard (cubic meter) for BACKFILL PLUGS.

Payment for temporary staging, if required, will be paid for according to Article 109.04.

Payment for accumulated stormwater removal and disposal will be according to Article 109.04. Payment will only be allowed if appropriate stormwater and erosion control methods were used.

Payment for decontamination, labor, material, and equipment for monitoring areas beyond the specified areas, with the Engineer's prior written approval, will be according to Article 109.04.

The sampling and testing associated with this work will be paid for as follows.

- (a) BETX Soil/Groundwater Analysis. When the contaminants of concern are gasoline only, soil or groundwater samples shall be analyzed for benzene, ethylbenzene, toluene, and xylenes (BETX). The analysis will be paid for at the contract unit price per each for BETX SOIL ANALYSIS and/or BETX GROUNDWATER ANALYSIS using EPA Method 8021B.
- (b) BETX-PNAS Soil/Groundwater Analysis. When the contaminants of concern are middle distillate and heavy ends, soil or groundwater samples shall be analyzed for BETX and polynuclear aromatics (PNAS). The analysis will be paid for at the contract unit price per each for BETX-PNAS SOIL ANALYSIS and/or BETX-PNAS GROUNDWATER ANALYSIS using EPA Method 8021B for BETX and EPA Method 8310 for PNAS.
- (c) Priority Pollutants Soil Analysis. When the contaminants of concern are used oils, soil samples shall be analyzed for priority pollutant VOCs, priority pollutants SVOCs, and priority pollutants metals. The analysis will be paid for at the contract unit price per each for PRIORITY POLLUTANTS SOIL ANALYSIS using EPA Method 8260B for VOCs, EPA Method 8270C for SVOCs, and using an ICP instrument and EPA Methods 6010B and 7471A for metals.

- (d) Priority Pollutant Groundwater Analysis. When the contaminants of concern are used oils, non-petroleum material, or unknowns, groundwater samples shall be analyzed for priority pollutant VOCs, priority pollutants SVOCs, and priority pollutants metals. The analysis will be paid for at the contract unit price per each for PRIORITY POLLUTANTS GROUNDWATER ANALYSIS using EPA Method 8260B for VOCs, EPA Method 8270C for SVOCs, and EPA Methods 6010B and 7470A for metals.
- (e) Target Compound List (TCL) Soil Analysis. When the contaminants of concern are unknowns or non-petroleum material, soil samples shall be analyzed for priority pollutant VOCs, priority pollutants SVOCs, priority pollutants metals, pesticides, and Resource Conservation and Recovery Act (RCRA) metals by the toxicity characteristic leaching procedure (TCLP). The analysis will be paid for at the contract unit price per each for TCL SOIL ANALYSIS using EPA Method 8260B for VOCs, EPA Method 8270C for SVOCs, EPA Method 8081 for pesticides, and ICP instrument and EPA Methods 6010B, 7471A, 1311 (extraction), 6010B, and 7470A for metals.
- (f) Soil Disposal Analysis. When the waste material for disposal requires sampling for disposal acceptance, the samples shall be analyzed for TCLP VOCs, SVOCs, RCRA metals, pH, ignitability, and paint filter test. The analysis will be paid for at the contract unit price per each for SOIL DISPOSAL ANALYSIS using EPA Methods 1311 (extraction), 8260B for VOCs, 8270C for SVOCs, 6010B and 7470A for RCRA metals, 9045C for pH, 1030 for ignitability, and 9095A for paint filter.

The work of preparing, submitting and administering a Regulated Substances Final Construction Report will be paid for at the contract lump sum price REGULATED SUBSTANCES FINAL CONSTRUCTION REPORT.”

REMOVAL OF DRAINAGE STRUCTURES

Description. This work shall consist of removing existing manholes, catch basins, and inlets.

General. The work shall be performed according to Section 605 of the “Standard Specifications” and the following:

The ends of existing drainage lines which are not to be incorporated into the proposed improvement (as determined by the Engineer) shall be sealed with bricks and portland cement mortar or mechanical end caps to the satisfaction of the Engineer. The cost of all materials required and all labor necessary to comply with the above provisions will not be paid for separately, but shall be considered as included in the unit bid prices of drainage items being removed.

Basis of Payment: This work will be paid for according to Article 605.06 of the “Standard Specifications”.

REMOVAL OF EXISTING PAVEMENT AND APPURTENANCES

Description. This work shall consist of the complete removal of existing pavement, paved shoulders, driveway pavement, median, curb, gutter, combination curb and gutter, paved ditch, and sidewalk.

General. The work shall be performed according to Section 440 of the “Standard Specifications” and the following:

The full depth, perpendicular, straight joint saw cut at the limits of the removal shall be included in the unit price of the item to be removed.

Should the Contractor deface any edge, a new sawed joint shall be provided and any additional work, including removal and replacement, shall be done at the Contractor’s expense.

Basis of Payment. This work will be paid for according to Article 440.08 of the “Standard Specifications”.

REMOVING EXISTING SEPTIC TANK

Description. This work shall consist of the removal of existing septic tank where identified on the plans.

General. This work shall be performed in compliance with the Part 905 Private Sewage Disposal Code of the Illinois Administrative Code and requirements of Lake County Health Department. Prior to the septic tank removal the Contractor shall hire a licensed sewage hauler to pump the contents of the septic tank out and obtain all the necessary permit documentation. Backfilling the work area shall not be measured for payment separately but shall be included in the cost of REMOVING EXISTING SEPTIC TANK.

Basis of Payment. This work shall be paid for at the contract unit price per each for REMOVING EXISTING SEPTIC TANK, which price shall include all labor, materials, and equipment required to complete the work.

SANITARY MANHOLES TO BE ADJUSTED; SANITARY MANHOLES TO BE REMOVED

Description. This work shall consist of adjusting the existing sanitary manholes to proposed elevation.

General. This work shall be done in accordance with Sections 602 and 605 of the Standard Specifications with the exception that the adjustment will include installation of a chimney seal.

Method of Measurement. This work shall be measured for payment per each sanitary structure adjusted, reconstructed, or removed.

Basis of Payment. This work shall be paid for at the contract unit price per each for SANITARY MANHOLES TO BE ADJUSTED or SANITARY MANHOLES TO BE REMOVED, which price shall include all labor, materials, and equipment required to complete the work.

STAINING CONCRETE STRUCTURES

Description: This work shall consist of staining exposed surfaces of form-lined concrete structures to replicate actual stone masonry.

The stain mix seeks to achieve the color variations present in similar natural limestone masonry constructions. Final coloration of the designated concrete surfaces shall accurately simulate the appearance of actual stone including multiple colors, shades, flecking, and veining. It shall also simulate the colors that may be present due to aging, staining, oxidation, rusting and/or organic

staining from soil and vegetation. The work shall include staining of all form-lined walls and parapets, including mortar joints, and noise abatement walls.

The following table summarizes the locations, form liner patterns, and staining colors to be applied:

Wall Type	Retaining Wall Finish/Color
Culvert & Wingwalls	Rustic drystack, Three color, buff, tan brown
MSE Walls	Rustic drystack, Three color, buff, tan brown

Concrete Stain Products: The stain shall provide a low-luster finish that will not peel, flake or fade and is resistant to oil, gasoline, water and UV rays. The vehicle type shall be 100% acrylic and fortified with crystalline silica. The stain shall have the following characteristics:

- 1) VOC (less exempt solvents) 224 g/L; 1.87 lb/gal
- 2) Water Vapor Transmission (ASTM D1653) 5.21 +/- 0.12 grains/(hr sq ft)
- 3) Perm Rating (ASTM D1653) 11.2 +/- .3 grains/ (hr sq ft in Hg)

The stain shall meet the following performance requirements:

- 1) Accelerated Weathering / Color Change (ASTM G154) 3000 hrs /no effect
- 2) Color & Gloss Retention (ASTM G90) Color: Less than .30 Change
Sheen: .5 difference @ 60 degrees
- 3) Chloride Ion Penetration (ASTM T 259/T 260) Reduction of 54% @ 0.0625-0.5” penetration, 83% @ 0.5-1.0” penetration and 36% @ 1.0-1.5” penetration
- 4) Resistance to Wind Driven Rain (Rilem Tube Method # 11.4) Zero water penetration over 60 minutes of exposure
- 5) Resistance to Salt Spray (ASTM B117) No film defect after 500 hours exposure
- 6) Resistance to Sulfide Staining (ASTM D1712) No change after 15 minutes
- 7) Chemical Resistance (10% Sodium Hydroxide) No softening or color change
- 8) Chemical Resistance (10% Ammonium Hydroxide) No softening or color change
- 9) Mineral Spirits KB Value 38 No softening or color change
- 10) Impact Resistance (Fed Std 141A, Method 2051, ASTM D2794) 6 inch-pounds direct impact with no film chipping
- 11) Flexibility (ASTM D522, Method B) 1 inch diameter mandrel with no cracking
- 12) Scrub Resistance 1200 cycles with no failure
- 13) Adhesion (ASTM 3359) Method A X-Cut Tape Test: No film loss (Class 5A) Method B Cross-Cut Tape test: Less than 5% removed (Class 4B)

Submittals and Sample Panel: Upon approval of the form liner type, the Contractor shall submit a manufacturer’s Product Data Sheet (PDS), Material Safety Data Sheet (MSDS) and

color chip palette with specific color choices indicated for the color stain and a PDS and MSDS for the finish coating. The Contractor shall also provide a surface preparation and painting plan with documentation of the application method and equipment and applicator experience and qualifications. Upon approval of the material selections and surface preparation and painting plan by the Owner and the casting of the concrete sample panel by others, the Contractor shall stain the cast concrete sample panel using the approved color selections and the appropriate techniques required to produce the appearance as desired by the Owner. The Contractor shall perform the staining and possible re-staining until the desired effect is achieved to the satisfaction of the Owner. No finish coating is required on the sample panel.

Execution: The Contractor shall strictly adhere to the manufacturer's recommendations, including those stated in the product PDS, in all facets of performing the work. These recommendations may include minimum concrete cure times, temperature, humidity and other weather restrictions, chemical etching of the raw concrete surfaces, surface power washing and cleaning and equipment selection and calibration. The color stains and finish coating shall only be applied with airless spray equipment unless otherwise authorized by the Engineer as coordinated with the Owner. The Contractor shall adequately protect adjacent surfaces from staining and finishing and shall clean the work area of all debris, materials and equipment when the Work is complete. Any surfaces, which have been damaged or splattered, shall be cleaned, restored, or replaced to the satisfaction of the Owner. No stain or finish coat shall be applied when wind-blown dust or debris is present or when work by others may compromise the finished work.

Method of Measurement: The exposed surfaces stained will be measured in place and the area computed in square feet.

Basis of Payment: This work will be paid for at the contract unit price per square foot for STAINING CONCRETE STRUCTURES. The unit price shall include all equipment, materials and labor required to stain and finish the exposed concrete surfaces.

STORM SEWER

Description. This work shall consist of constructing storm sewers.

General. The work shall be performed according to Section 550 of the "Standard Specifications" and the following:

The cost of connecting proposed storm sewer to existing structures shall be included in the unit cost of the proposed storm sewer. Additional pipe required to complete the connections will be paid for at the contract unit price for STORM SEWER of the type, size and class required.

All joints in concrete sewer pipe shall be sealed with rubber gaskets, preformed joint sealants, or external sealing bands. No mastic joint sealer will be allowed.

Temporary sheeting or bracing for sewer trenches that may be required shall be the responsibility of the Contractor. The cost of this work shall be included in the unit price for STORM SEWER of the type, size and class specified.

The Contractor shall be aware that at times the Engineer may require a change in storm sewer elevation due to a utility line or other obstruction. The additional excavation or sheeting required shall be considered as included in the cost of the storm sewer.

At locations where the proposed storm sewer crosses over utilities, a 4" Styrofoam cushion shall be placed under the storm sewer when directed to do so by the Engineer. This work shall be included in the unit price for STORM SEWER of the type, size and class specified.

Non-shear couplings shall be used for connections of new pipe to existing pipe and where dissimilar pipe and joint materials are encountered. Couplings shall be a minimum of 12 inches long for connection on larger pipes (these are special order items). No stainless steel shear rings will be allowed. The cost of all materials required and all labor necessary to comply with the above provisions will not be paid for separately, but shall be considered as included in the cost of the proposed pipe.

Basis of Payment. This work will be paid for according to Article 550.10 of the "Standard Specifications".

STORM SEWER REMOVAL AND INSTALLATION

Description. This work shall consist of the removal and/or installation of storm sewers, including laterals.

General. The work shall be performed according to Section 551 of the "Standard Specifications" and the following:

All storm sewer scheduled for removal will be examined by the Engineer to determine if the item is suitable for salvage.

Items designated for salvage shall be carefully removed and stored at the location and in the manner designated by Engineer. Any of the material having salvage value which is damaged by the Contractor shall be replaced by the Contractor, at his/her own expense, with new items of the same kind and size. The cost of storing salvaged items shall be included in the unit cost of the storm sewer being removed.

Items not designated for salvage shall be transported from the project site and dispose of them outside the ROW according to Article 202.03 of the "Standard Specifications".

Trenches resulting from the removal of pipe culverts shall be backfilled in accordance with the applicable requirements of Article 550.07 of the "Standard Specifications".

Removal of end sections shall be paid for as "STORM SEWER REMOVAL" unless indicated otherwise on the plans.

If during construction, the Contractor encounters or otherwise becomes aware of any sewers or underdrains within the right-of-way other than those shown on the plans, he/she shall inform the Engineer, who shall direct the work necessary to maintain or replace the facilities in service and to protect them from damage during construction if maintained. Existing facilities to be maintained that are damaged because of non-compliance with this provision shall be replaced at the Contractor's own expense. Should the Engineer direct the replacement of a facility, the necessary work and payment shall be according to Sections 550 and 601, and Article 104.02 of the "Standard Specifications".

When existing drainage facilities are disturbed, the Contractor shall provide and maintain temporary outlets and connections for all private or public drains, sewers or structures. He/she shall provide facilities to take in all storm water which will be received by these drains and sewers, and discharge the same. He/she shall provide and maintain an efficient pumping plant, if necessary, and a temporary outlet. He/she shall be prepared at all times to dispose of the water received from temporary connections until such time as the permanent connections with sewers are built and in service. The cost of all materials required and all labor necessary to comply with the above provisions will not be paid for separately, but shall be considered as included in the cost of drainage removal items.

Basis of Payment: This work will be paid for according to Article 551.06 of the "Standard Specifications".

STORM SEWERS, CLASS B, 8"

Description. This work shall consist of furnishing and placing a storm sewer as shown on the plans.

General. This work shall be done in accordance with Sections 550 of the Standard Specifications.

Method of Measurement. STORM SEWER, CLASS B, 8" will be measured for payment in place and the length computed in feet.

Basis of Payment. This work shall be paid for at the contract unit price per foot of STORM SEWER, CLASS B, 8" of the type specified, which price shall include joint materials, fittings, and all materials, labor and equipment necessary to perform the work as here in specified.

STORM SEWERS, WATER MAIN QUALITY PIPE

Description. This work shall consist of constructing storm sewer at the direction of the Engineer in areas where the minimum horizontal separation from water main and/or water service lines cannot be maintained. The separation requirements are defined in the Standard Specifications for Water & Sewer Main Construction in Illinois.

Materials. The storm sewer materials shall be limited to the following:

- Concrete Pressure Pipe: The concrete pressure pipe shall meet the requirements of the latest AWWA Standards C300, C301, and C303. The structural design of pre-stressed concrete cylinder pipe shall be according to the latest addition of AWWA Standard C304.
- Ductile Iron Pipe: The ductile iron pipe shall meet the requirements of ANSI A 21.51 (AWWA C151). The class or thickness design shall be according to ANSI A 21.50 (AWWA C150). The ductile iron pipe shall be seal coated and/or cement lined according to ANSI A 21.4 (AWWA C104). The ductile iron pipe shall have mechanical or rubber (slip seal or push on) joints.
- Plastic Pipe: The plastic pipe may be composed of Polyvinyl Chloride (PVC) or Polyethylene (PE) pipe. The PVC or PE material shall meet the requirements of NSF (National Sanitation Foundation) standard 14 and the AWWA or ASTM designated standard shown in the following table. The dimension ratio shall be less than the maximum value shown in the table below:



AWWA Standard	Material (Material Code)	Dimension Ratio Maximum
C900	PVC	25
C905	PVC	26
C906	PE (PE 3048)	17
	PE (PE 2406)	13.5
	PE (PE 3406)	
ASTM D 1785	PVC (PVC 1120) PVC (PVC 1220)	26
ASTM D 2241	PVC (PVC 1120) PVC (PVC 1220)	26

- ASTM D 1785 and ASTM D 2241 PVC pipe shall be rated at 160 psi or greater at 73.4°F.
 - Additional guidance is available in the Standard Specifications for Water & Sewer Construction in Illinois.
- **Steel Pipe:** The steel water pipe shall meet the requirements of the latest AWWA Standard C200. The structural design shall be according to the latest edition of C200 and AWWA Manual M-11 shall serve as the standard of practice for design and installation.

General. The work shall be performed according to Section 550 of the “Standard Specifications” and 35 Illinois Administrative Code 653.119, which requires the storm sewer to be pressure tested (for storm sewers where 10’ horizontal separation from water main is not met) to the maximum expected surcharge pressure before backfilling.

For this project the maximum expected surcharge pressure is 68 psi.

Method of Measurement. Storm Sewers, Water Main Quality Pipe will be measured for payment in place in feet. The measurement shall be according to Article 550.09 of the “Standard Specifications”.

Basis of Payment. This work will be paid for at the contract unit price per foot for STORM SEWER (WATER MAIN REQUIREMENTS) of the diameter specified regardless of type. The unit price shall include all equipment, materials and labor necessary to complete the work as specified. The cost of pressure testing the storm sewer included in the unit price for STORM SEWER (WATER MAIN REQUIREMENTS).

SURVEY MONUMENTS

The Contractor shall furnish and install survey monuments at the locations indicated on the plans.

After the final surface course has been placed the Engineer will install four survey nails for each point to be monumented. The Contractor shall use the following procedure to install the survey monuments.

1. At each monument location, the Engineer shall install four survey nails in the surface. Each nail shall be one foot from the center and in a direct line with the opposite nail to be used for setting the new monument.
2. The Contractor shall use a hammer drill mounted with a 1¼” diameter masonry bit, to drill a hole 4½” deep, centered within the four survey nails.

3. The Contractor shall use a drilling machine mounted with a four inch diamond core bit, to cut a hole, $\frac{3}{4}$ " deep, centered on the initial hole. The Contractor shall chisel out the hole to a level depth of $\frac{3}{4}$ ".
4. The Contractor shall remove debris from the hole and insure that it is dry before applying the epoxy adhesive.
5. The Contractor shall fill the hole with an epoxy adhesive. The adhesive shall be a two-component epoxy adhesive meeting the requirements of ASTM Specification C881, Type IV, Grade 3 for temperatures at or above 50°F or AASHTO Specification M237-90, Table 2 Type III for the two component, epoxy adhesive if the temperature is between 31°F and 50°F.
6. The Contractor shall place the new monument in the center of the hole. Set the monument so that the center of the legend top is $\frac{3}{8}$ " below the pavement surface. Aggregate can be used to adjust the monument elevation to obtain the correct depth.
7. The Contractor shall use the four survey nails and a string line or $\frac{1}{8}$ " chalk line to center the monument in the hole to the nearest 0.005 foot. This can be accomplished by drawing the string across two diagonally opposite survey nails.
8. Each monument shall be protected from traffic for a minimum of 90 minutes.
9. The Contractor shall notify the Engineer prior to installing the survey monuments. The Engineer shall be present during the installation process.

This work will be paid for at the contract unit price each for SURVEY MONUMENTS, which shall include all work and materials to complete the installation.

TEMPORARY DITCH CHECKS

Description. This work shall consist of furnishing, constructing, maintaining, and removing temporary ditch checks.

General. The work shall be performed according to Section 280 of the "Standard Specifications", LCDOT Standard Drawing LC2050 and the following:

The temporary ditch check shall be triangular shaped, urethane foam covered with a geotextile fabric. The temporary ditch check shall be installed on a geotextile fabric apron. The temporary ditch check shall have a triangle base 16" – 20" wide and a minimum triangle height of 8" – 10". The temporary ditch checks shall be installed at the locations specified on the Erosion Control Plan, and/or as directed by the Engineer. The temporary ditch check installation shall be according to the detail shown on the plans and the manufacturer's recommendations.

The geotextile fabric shall conform to Article 1080.05 of the “Standard Specifications”, for Geotechnical Fabric for French Drains.

The temporary ditch checks shall remain in place until just before placing the final landscaping in the ditch area. The Contractor shall not remove the temporary ditch checks if it is raining and/or rain is in the immediate forecast.

The ditch checks shall become the property of the Contractor upon their removal.

During the construction operation when any loose material is deposited in the flow line of ditches, gutters or drainage structures so the natural flow of water is obstructed, the material shall be removed at the close of each working day.

At the conclusion of the construction operations all drainage structures shall be free from all dirt and debris. This work will not be paid for separately but shall be considered included in the unit cost of TEMPORARY DITCH CHECKS.

Method of Measurement. Temporary Ditch Checks will be measured in place and the length calculated in feet for each ditch check section actually installed.

Basis of Payment. This work will be paid for at the contract unit price per foot for TEMPORARY DITCH CHECKS. The unit price shall include all work and materials necessary to properly install the temporary ditch checks, maintain the temporary ditch checks throughout the project, and to remove and dispose of the used materials at the completion of the project.

TEMPORARY DITCH CHECKS (SPECIAL)

Description: This work shall consist of furnishing, installing, maintaining, and removing a permeable plastic berm. The plastic berm may be used in conjunction with erosion control mat, sediment bags and other components of a water treatment train and/or as a temporary ditch check while establishing final landscaping.

For this project the Permeable Plastic Berms shall be used for:

- A component of a water treatment train*
- A temporary ditch check while establishing final landscaping*

Materials: The permeable plastic berm shall be constructed of High Density Polyethylene (HDPE) with a UV inhibitor. The permeable plastic berm shall have 35-40% porosity. The berm shall be a minimum of 8¾” tall.

General: The work shall be performed according to Section 280 of the “Standard Specifications”, and the manufacturer’s recommendations.

Water Treatment Train:

The permeable plastic berm shall be used in conjunction with the erosion control mat, flocculation powder and other components to form a water treatment train as directed by the Engineer. The permeable plastic berm shall become the property of the Contractor upon the dismantling and removal of the water treatment train.

Temporary Ditch Check:

The permeable plastic berm shall be used as a temporary ditch check in ditch lines where the erosion control blanket has been placed and the seeding operations performed. The permeable plastic berms shall be placed in the locations of the Temporary Ditch Checks and/or as directed by the Engineer. Their installation shall be according to the detail shown on the plans and the manufacturer's recommendations. After the final landscaping has been established to the satisfaction of the Engineer the permeable plastic berm shall be removed by the Contractor. The permeable plastic berm shall become the property of the Contractor upon removal.

Method of Measurement:

Water Treatment Train: The permeable plastic berm will be measured for payment in feet for the actual length used in a water treatment train.

Temporary Ditch Check: The Permeable Plastic Berm will be measured in place and the length calculated in feet for each permeable plastic berm actually installed.

Basis of Payment: This work will be paid for at the contract unit price per foot for TEMPORARY DITCH CHECKS (SPECIAL). The unit price shall include all labor, equipment and materials necessary for the installation, maintenance, and removal of the plastic berm regardless of use.

TEMPORARY HEAVY DUTY EROSION CONTROL BLANKET

Description. This work shall consist of furnishing, placing and removing erosion control mat in ditch bottoms along with a flocculation powder application as a temporary erosion control measure before final stabilization with erosion control blanket and seeding.

Materials. The erosion control mat shall be limited to jute fabric according to the following:

The erosion control mat shall be a woven fabric of a uniform open weave of single jute yarn. The jute yarn shall be of loosely twisted construction with an average twist of not less than 1½ turns per 1". The average size of the warp and weft yarns shall be approximately the same. The woven fabric shall be supplied in rolled strips with a certificate of compliance certifying that the jute fabric erosion mat conforms to the following:

- That the erosion control mat is a minimum 48” wide with a tolerance of minus 1”.
- That the erosion control mat has 78 warp ends, +/- 1 for each 48” of width.
- That the erosion control mat has 45 weft yarns, +/- 2, per linear yard of length.
- That the erosion control mat weighs 92 pounds per 100 square yards +/- 10 percent, measured under average atmospheric conditions.
- That the erosion control mat is non-toxic to vegetation.

General. The work shall be performed according to Article 251.04 of the “Standard Specifications” and the manufacturer’s recommendations.

Method of Measurement. This work will be measured for payment per square yard of material placed. Each installation of the erosion control mat shall be measured for payment. The flocculation powder will be measured separately according to the special provision for FLOCCULATION POWDER contained herein.

Basis of Payment. This work will be paid for at the contract unit price per square yard for TEMPORARY HEAVY DUTY EROSION CONTROL BLANKET. The unit price shall include all labor, equipment and materials necessary for installation, removal and disposal of the erosion control mat. The flocculation powder will be paid for separately according to the special provision for FLOCCULATION POWDER contained herein.

TEMPORARY PAVEMENT (VARIABLE DEPTH)

Description. This work shall consist of constructing temporary ramps to eliminate vertical pavement drop-offs during construction staging as shown on the plans or as directed by the Engineer.

General. The work shall be performed according to Section 406 of the “Standard Specifications” and shall be constructed at the direction of Engineer between binder and surface courses as necessary.

Temporary ramps shall be asphalt and provisions in section 406.08(a) of the “Standard Specifications” shall apply.

Basis of Payment. This work will be paid for at the contract unit price per ton for TEMPORARY PAVEMENT (VARIABLE DEPTH), which price shall include all equipment, materials and labor required to install and remove temporary ramps.

TEMPORARY SIDEWALK

Description. This work shall consist of constructing temporary sidewalks and sidewalk accessibility ramps on a prepared subgrade in order to provide ADA-compliant routes for

pedestrians through the construction work zone at the locations shown on the plans or where directed by the Engineer.

General. Temporary sidewalks shall be constructed of Hot-Mix Asphalt Surface Course, Mix D, N50 with a minimum compacted thickness of 3 inches. This work shall be constructed in accordance with the applicable portions of Section 406 of the Standard Specifications and as directed by the Engineer. The material shall conform to the applicable portions of Section 1030 of the Standard Specifications. The subgrade shall be prepared in accordance with Article 424.04 of the Standard Specifications. Detectable warnings shall be installed in accordance with Article 424.09 of the Standard Specifications and the Highway Standards included in the plans.

Stone shall not be required when the temporary sidewalk is constructed outside the limits of the proposed pavement. All stone required to construct the temporary sidewalks through the areas that will be paved shall be included in the cost of AGGREGATE FOR TEMPORARY ACCESS.

Method of Measurement. This work will be measured for payment in place and the area computed in square feet. No deduction will be made for detectable warnings located within ramps.

Detectable warnings will be measured for payment in place and the area computed in square feet.

Earth excavation will be measured for payment according to Article 202.07.

Basis of Payment. This work shall be paid for at the contract unit price per square foot for TEMPORARY SIDEWALK, which price shall include all equipment, materials and labor required to provide and remove the temporary sidewalk and remove the detectable warnings.

Furnishing and installing detectable warnings will be paid for at the contract unit price per square foot for DETECTABLE WARNINGS.

Earth excavation will be paid for according to Article 202.08.

TOPSOIL FURNISH AND PLACE

Description. This work shall consist of furnishing, excavating, transporting and placing topsoil.

Materials. Topsoil (furnished from outside the right-of-way) shall meet the requirements of Article 1081.05(a) of the "Standard Specifications".

General. The work shall be performed according to Section 211 of the "Standard Specifications" and the following:

The work shall also comply with the "Illinois State Agency Historic Resources Preservation Act" (Public Act 86-707, effective January 1, 1990). Under this Act:

1. The Contractor shall complete a Cultural and Natural Resources Review of Borrow Areas form for Borrow/Waste/Use Areas (BDE form 2289 3/14/16 included herein), along with all required attachments, and submit them to the Engineer at the earliest possible date.
2. The Engineer shall submit the Cultural and Natural Resources Review of Borrow Areas form to IDOT for review and approval. Any and all costs incurred, associated with said review and approval will be borne by the Contractor.
3. The Contractor shall not begin work on any Borrow/Use areas until the Cultural and Natural Resources Review of Borrow Areas form has been approved.

The Contractor shall collect one representative soil sample from the proposed growing surface which shall be analyzed by an agricultural laboratory approved by the Engineer. The Contractor shall submit the proposed laboratory name and address to the Engineer at the pre-construction conference. The soils analysis shall include (but is not limited to) the recommended application rates of nitrogen and potassium fertilizer nutrients.

Method of Measurement. Topsoil Furnish and Place will be measured for payment in square yards according to Article 211.07 of the "Standard Specifications".

Basis of Payment. This work will be paid for at the contract unit price per square yard for TOPSOIL FURNISH AND PLACE, of the thickness specified. The cost of the soil analysis will not be paid for separately, but will be included in the cost of TOPSOIL FURNISH AND PLACE. The unit price shall include all equipment, materials and labor required to furnish and place the topsoil.

TREE PROTECTION AND PRESERVATION

Description. This work shall consist of establishing "tree protection zones" around the trees in the vicinity of construction that are designated to be preserved.

General. Every effort shall be made by the Contractor when working near trees and shrubs to preserve same from harm. No trees or shrubs shall be removed unless directed by the Engineer. The Contractor shall be responsible for damage to or loss of any tree or shrub not specifically designated to be removed.

Wherever trees which are not permitted to be removed interfere with normal excavation procedures, the following shall govern. No machine excavation shall be made within a distance of three tree trunk diameters or 12 inches (whichever is greater) of any tree, and no roots over 2 inches in diameter shall be cut unless, in the opinion of the Engineer, it is impossible to complete

the work without cutting. Excavation closer than three trunk diameters or 12 inches (whichever is greater) from any tree shall be made by hand, and the tree shall be tunneled where necessary as determined by the Engineer.

Damage to tree limbs shall be held to a minimum. Shrubs and tree limbs shall be tied back wherever necessary to prevent their loss or damage. Wherever damage by construction equipment to limbs and branches is unavoidable, they shall be pruned before starting work and sealed in accordance with best forestry practice.

When directed by the Engineer, the Contractor shall provide plank wrappers wired in place to protect tree trunks from being damaged by trench machinery, tractors or trucks. Protective planking shall be removed as soon as practical after the work in the vicinity has been completed. In removing spoil banks from around trees, hand work will be required as necessary to prevent damage to the trunks by construction machinery.

Damages at the rate of one hundred dollars (\$100.00) per each 1-inch of trunk diameter shall be charged against the Contractor for unauthorized removal or destruction of any tree 4-inch in diameter or larger as determined by the Engineer.

Construction:

1. The Contractor shall erect a temporary fence around all trees within the construction area to establish a “tree protection zone” before any work begins or any material is delivered to the jobsite. No work is to be performed (other than root pruning), materials stored, or vehicles driven or parked within the “tree protection zone” at any time during the course of construction.
2. The exact location and establishment of the “tree protection zone” fence shall be approved by the Engineer prior to setting the fence. The fence shall be 48 inches high, plastic poly-type or any other type of highly visible barrier in an open-weave type pattern with large openings. The type, color and pattern of the fence shall be approved by the Engineer prior to erection. This fence shall be properly maintained in an upright manner and shall remain up until final restoration, unless the Engineer directs removal otherwise. Tree fence shall be supported using T-Post style fence posts with a maximum of 8’ spacing. T-posts must be at least six feet in length, two feet of which must be set in the ground. The fence shall be attached to posts and secured with a minimum of three nylon locking ties per post. **Utilizing re-bar as a fence post will not be permitted.**
3. The fence shall be installed parallel to the curb and between the curb and sidewalk unless otherwise directed by the Engineer. Fence shall be erected on a minimum of three sides with the fourth sidewalk side being optional. Fence shall be installed at the drip-line of the tree or as listed in the following guidelines:

- a. Establish the diameter of the tree at a point four and a half feet above the ground, (referred to as diameter breast height or DBH)
 - i.. Trees with diameters 10 inches and under require root zone protection a minimum of five feet in all directions from the center of the tree.
 - ii. Trees 10 to 19 inches in diameter shall have a minimum root zone protection of 10 feet in all directions from the center of the tree.
 - iii. Trees greater than 19 inches in diameter shall have a minimum root zone protection of 15 feet in all directions from the center of the tree.
4. Parking or maneuvering of machinery, stockpiling of materials or any other use will not be allowed upon unpaved areas within 3 m (10 ft) of the root protection zone of trees or plants designated to be protected.
5. Construction area is defined as all areas within 20 feet each side of water or sewer main location.
6. All work within the “tree protection zone” shall have the Engineer’s prior approval. All slopes and other areas not re-graded should be avoided so that unnecessary damage is not done to the existing turf, tree root system or ground cover.
7. The grade within the “tree protection zone” shall not be changed unless approved by the Engineer prior to making said changes or performing the work.

Basis of Payment. Temporary fence will be paid for at the contract unit price per foot for TEMPORARY FENCE, which price shall include furnishing, installing, maintaining, and removing. Tree pruning will be paid for at the contract unit price per each for TREE PRUNING (1 TO 10 INCH DIAMETER) and/or TREE PRUNING (OVER 10 INCH DIAMETER), which price shall include labor, materials, and equipment. Root pruning will be paid for at the contract unit price per each for TREE ROOT PRUNING, which price shall include labor, materials, and equipment.

TREE REMOVAL

Description. This work shall consist of cutting, grubbing, removing and disposing of trees and stumps.

General. The work shall be performed according to Article 201.04 of the “Standard Specifications” and the following:

Cut trees and limbs shall be disposed of within five working days. The cut trees and limbs shall be disposed of according to Article 202.03 of the “Standard Specifications”.

Method of Measurement. Tree Removal will be measured for payment according to Article 201.10(b) of the “Standard Specifications”.

Basis of Payment. This work will be paid for at the contract unit price per unit diameter for TREE REMOVAL of the size range specified. The unit price shall include all equipment, materials and labor required to remove and dispose of designated trees and stumps.

TREE ROOT PRUNING

Description. This work shall consist of pruning existing tree roots prior to trenching or excavation operations.

General. The work shall be performed according to Article 201.06 of the “Standard Specifications” and the following:

Before any trenching or excavation in the area of a tree, tree roots shall be cut with appropriate root pruning equipment to a minimum of 24” deep. The cuts shall be made 6” to 12” closer to the tree than the construction limit. This allows for root regeneration (within the 6” to 12” area) during the construction period. Pruning shall not be done at the construction limit, since the cut surfaces of the roots will remain exposed resulting in root dieback.

The application of Fertilizer Nutrients and Supplemental Watering shall be performed according to Article 201.06 of the “Standard Specifications”. The Fertilizer Nutrients and Supplemental Watering shall not be paid for separately, but shall be included in the contract unit price for TREE ROOT PRUNING.

Removed material shall be disposed outside the right of way according to Article 202.03 of the “Standard Specifications”.

Method of Measurement. Tree Root Pruning will be measured for payment as each per tree according to Article 201.10(d) of the “Standard Specifications”.

Basis of Payment. This work will be paid for at the contract unit price per each for TREE ROOT PRUNING. The unit price shall include all equipment, materials, and labor required to prune the existing tree roots and to transport & dispose of the removed material. The unit price shall also include all equipment materials and labor required to accomplish the application of the fertilizer nutrients and supplemental watering.

AGGREGATE SUBGRADE IMPROVEMENT (D-1)

Effective: February 22, 2012

Revised: April 1, 2016

Add the following Section to the Standard Specifications:

“SECTION 303. AGGREGATE SUBGRADE IMPROVEMENT

303.01 Description. This work shall consist of constructing an aggregate subgrade improvement.

303.02 Materials. Materials shall be according to the following.

Item	Article/Section
(a) Coarse Aggregate	1004.07
(b) Reclaimed Asphalt Pavement (RAP) (Notes 1, 2 and 3)	1031

Note 1. Crushed RAP, from either full depth or single lift removal, may be mechanically blended with aggregate gradation CS 01 but shall not exceed 40 percent by weight of the total product. The top size of the Coarse RAP shall be less than 4 in. (100 mm) and well graded.

Note 2. RAP having 100 percent passing the 1 1/2 in (37.5 mm) sieve and being well graded, may be used as capping aggregate in the top 3 in. (75 mm) when aggregate gradation CS 01 is used in lower lifts. When RAP is blended with any of the coarse aggregates, the blending shall be done with mechanically calibrated feeders. The final product shall not contain more than 40 percent by weight of RAP.

Note 3. The RAP used for aggregate subgrade improvement shall be according to the current Bureau of Materials and Physical Research Policy Memorandum, “Reclaimed Asphalt Pavement (RAP) for Aggregate Applications”.

303.03 Equipment. The vibratory machine shall be according to Article 1101.01, or as approved by the Engineer. The calibration for the mechanical feeders shall have an accuracy of ± 2.0 percent of the actual quantity of material delivered.

303.04 Soil Preparation. The stability of the soil shall be according to the Department’s Subgrade Stability Manual for the aggregate thickness specified.

303.05 Placing Aggregate. The maximum nominal lift thickness of aggregate gradation CS 01 shall be 24 in. (600 mm).

303.06 Capping Aggregate. The top surface of the aggregate subgrade shall consist of a minimum 3 in. (75 mm) of aggregate gradations CA 06 or CA 10. When Reclaimed Asphalt Pavement (RAP) is used, it shall be crushed and screened where 100 percent is passing the

1 1/2 in. (37.5 mm) sieve and being well graded. RAP that has been fractionated to size will not be permitted for use in capping. Capping aggregate will not be required when the aggregate subgrade improvement is used as a cubic yard pay item for undercut applications. When RAP is blended with any of the coarse aggregates, the blending shall be done with mechanically calibrated feeders.

303.07 Compaction. All aggregate lifts shall be compacted to the satisfaction of the Engineer. If the moisture content of the material is such that compaction cannot be obtained, sufficient water shall be added so that satisfactory compaction can be obtained.

303.08 Finishing and Maintenance of Aggregate Subgrade Improvement. The aggregate subgrade improvement shall be finished to the lines, grades, and cross sections shown on the plans, or as directed by the Engineer. The aggregate subgrade improvement shall be maintained in a smooth and compacted condition.

303.09 Method of Measurement. This work will be measured for payment according to Article 311.08.

303.10 Basis of Payment. This work will be paid for at the contract unit price per cubic yard (cubic meter) for AGGREGATE SUBGRADE IMPROVEMENT or at the contract unit price per square yard (square meter) for AGGREGATE SUBGRADE IMPROVEMENT, of the thickness specified.

Add the following to Section 1004 of the Standard Specifications:

“ **1004.07 Coarse Aggregate for Aggregate Subgrade Improvement.** The aggregate shall be according to Article 1004.01 and the following.

- (a) Description. The coarse aggregate shall be crushed gravel, crushed stone, or crushed concrete. The top 12 inches of the aggregate subgrade improvement shall be 3 inches of capping material and 9 inches of crushed gravel, crushed stone or crushed concrete. In applications where greater than 36 inches of subgrade material is required, rounded gravel, meeting the CS01 gradation, may be used beginning at a depth of 12 inches below the bottom of pavement.
- (b) Quality. The coarse aggregate shall consist of sound durable particles reasonably free of deleterious materials. Non-mechanically blended RAP may be allowed up to a maximum of 5.0 percent.
- (c) Gradation.
 - (1) The coarse aggregate gradation for total subgrade thicknesses of 12 in. (300 mm) or greater shall be CS 01.

COARSE AGGREGATE SUBGRADE GRADATIONS					
Grad No.	Sieve Size and Percent Passing				
	8"	6"	4"	2"	#4
CS 01	100	97 ± 3	90 ± 10	45 ± 25	20 ± 20

COARSE AGGREGATE SUBGRADE GRADATIONS (Metric)					
Grad No.	Sieve Size and Percent Passing				
	200 mm	150 mm	100 mm	50 mm	4.75 mm
CS 01	100	97 ± 3	90 ± 10	45 ± 25	20 ± 20

(2) The 3 in. (75 mm) capping aggregate shall be gradation CA 6 or CA 10.

AGGREGATE SURFACE COURSE FOR TEMPORARY ACCESS (D-1)

Effective: April 1, 2001

Revised: January 2, 2007

Revise Article 402.10 of the Standard Specifications to read:

“402.10 For Temporary Access. The contractor shall construct and maintain aggregate surface course for temporary access to private entrances, commercial entrances and roads according to Article 402.07 and as directed by the Engineer.

The aggregate surface course shall be constructed to the dimensions and grades specified below, except as modified by the plans or as directed by the Engineer.

- (a) Private Entrance. The minimum width shall be 12 ft (3.6 m). The minimum compacted thickness shall be 6 in. (150 mm). The maximum grade shall be eight percent, except as required to match the existing grade.
- (b) Commercial Entrance. The minimum width shall be 24 ft (7.2 m). The minimum compacted thickness shall be 9 in. (230 mm). The maximum grade shall be six percent, except as required to match the existing grade.
- (c) Road. The minimum width shall be 24 ft (7.2 m). The minimum compacted thickness shall be 9 in. (230 mm). The grade and elevation shall be the same as the removed pavement, except as required to meet the grade of any new pavement constructed.

Maintaining the temporary access shall include relocating and/or regrading the aggregate surface course for any operation that may disturb or remove the temporary access. The same type and gradation of material used to construct the temporary access shall be used to maintain it.

When use of the temporary access is discontinued, the aggregate shall be removed and utilized in the permanent construction or disposed of according to Article 202.03.”

Add the following to Article 402.12 of the Standard Specifications:

“Aggregate surface course for temporary access will be measured for payment as each for every private entrance, commercial entrance or road constructed for the purpose of temporary access. If a residential drive, commercial entrance, or road is to be constructed under multiple stages, the aggregate needed to construct the second or subsequent stages will not be measured for payment but shall be included in the cost per each of the type specified.”

Revise the second paragraph of Article 402.13 of the Standard Specifications to read:

“Aggregate surface course for temporary access will be paid for at the contract unit price per each for TEMPORARY ACCESS (PRIVATE ENTRANCE), TEMPORARY ACCESS (COMMERCIAL ENTRANCE) or TEMPORARY ACCESS (ROAD).

Partial payment of the each amount bid for temporary access, of the type specified, will be paid according to the following schedule:

- (a) Upon construction of the temporary access, sixty percent of the contract unit price per each, of the type constructed, will be paid.
- (b) Subject to the approval of the Engineer for the adequate maintenance and removal of the temporary access, the remaining forty percent of the pay item will be paid upon the permanent removal of the temporary access.”

COARSE AGGREGATE FOR BACKFILL, TRENCH BACKFILL AND BEDDING (D-1)

Effective: November 1, 2011

Revised: November 1, 2013

This work shall be according to Section 1004.05 of the Standard Specifications except for the following:

Reclaimed Asphalt Pavement (RAP) may be blended with gravel, crushed gravel, crushed stone, crushed concrete, crushed slag, chats, crushed sand stone or wet bottom boiler slag. The RAP used shall be according to the current Bureau of Materials and Physical Research Policy Memorandum, "Reclaimed Asphalt Pavement (RAP) for Aggregate Applications". The RAP shall be uniformly graded and shall pass the 1.0 in. (25 mm) screen. When RAP is blended with any of the coarse aggregate listed above, the blending shall be done mechanically with calibrated feeders. The feeders shall have an accuracy of ± 2.0 percent of the actual quantity of material delivered. The final blended product shall not contain more than 40 percent by weight RAP.

The coarse aggregate listed above shall meet CA 6 and CA 10 gradations prior to being blended with the processed and uniformly graded RAP. Gradation deleterious count shall not exceed 10% of total RAP and 5% of other by total weight

EMBANKMENT I (D-1)

Effective: March 1, 2011

Revised: November 1, 2013

Description. This work shall be according to Section 205 of the Standard Specifications except for the following.

Material. All material shall be approved by the District Geotechnical Engineer. The proposed material must meet the following requirements.

- a) The laboratory Standard Dry Density shall be a minimum of 90 lb/cu ft (1450 kg/cu m) when determined according to AASHTO T 99 (Method C).
- b) The organic content shall be less than ten percent determined according to AASHTO T 194 (Wet Combustion).
- c) Soils which demonstrate the following properties shall be restricted to the interior of the embankment and shall be covered on both the sides and top of the embankment by a minimum of 3 ft (900 mm) of soil not considered detrimental in terms of erosion potential or excess volume change.
 - 1) A grain size distribution with less than 35 percent passing the number 75 um (#200) sieve.
 - 2) A plasticity index (PI) of less than 12.
 - 3) A liquid limit (LL) in excess of 50.
- d) Reclaimed asphalt shall not be used within the ground water table or as a fill if ground water is present.
- e) The RAP used shall be according to the current Bureau of Materials and Physical Research Policy Memorandum, "Reclaimed Asphalt Pavement (RAP) for Aggregate Applications". Gradation deleterious count shall not exceed 10% of total RAP and 5% of other by total weight.

CONSTRUCTION REQUIREMENTS

Samples. Embankment material shall be sampled, tested, and approved before use. The contractor shall identify embankment sources, and provide equipment as the Engineer requires, for the collection of samples from those sources. Samples will be furnished to the Geotechnical Engineer a minimum of three weeks prior to use in order that laboratory tests for approval and compaction can be performed. Embankment material placement cannot begin until tests are completed and approval given.

Placing Material. In addition to Article 202.03, broken concrete, reclaimed asphalt with no expansive aggregate, or uncontaminated dirt and sand generated from construction or demolition activities shall be placed in 6 inches (150 mm) lifts and disked with the underlying lift until a uniform homogenous material is formed. This process also applies to the overlaying lifts. The disk must have a minimum blade diameter of 24 inches (600 mm).

When embankments are to be constructed on hillsides or existing slopes that are steeper than 3H:1V, steps shall be keyed into the existing slope by stepping and benching as shown in the plans or as directed by the engineer.

Compaction. Soils classification for moisture content control will be determined by the Soils Inspector using visual field examination techniques and the IDH Textural Classification Chart.

When tested for density in place each lift shall have a maximum moisture content as follows.

- a) A maximum of 110 percent of the optimum moisture for all forms of clay soils.
- b) A maximum of 105 percent of the optimum moisture for all forms of clay loam soils.

Stability. The requirement for embankment stability in Article 205.04 will be measured with a Dynamic Cone Penetrometer (DCP) according to the test method in the IDOT Geotechnical Manual. The penetration rate must be equal or less than 1.5 inches (38 mm) per blow.

Basis of Payment. This work will not be paid separately but will be considered as included in the various items of excavation.

FRICITION AGGREGATE (D-1)

Effective: January 1, 2011

Revised: April 29, 2016

Revise Article 1004.03(a) of the Standard Specifications to read:

“1004.03 Coarse Aggregate for Hot-Mix Asphalt (HMA). The aggregate shall be according to Article 1004.01 and the following.

(a) Description. The coarse aggregate for HMA shall be according to the following table.

Use	Mixture	Aggregates Allowed
Class A	Seal or Cover	<u>Allowed Alone or in Combination</u> ^{5/} : Gravel Crushed Gravel Carbonate Crushed Stone Crystalline Crushed Stone Crushed Sandstone Crushed Slag (ACBF) Crushed Steel Slag Crushed Concrete
HMA Low ESAL	Stabilized Subbase or Shoulders	<u>Allowed Alone or in Combination</u> ^{5/} : Gravel Crushed Gravel Carbonate Crushed Stone Crystalline Crushed Stone Crushed Sandstone Crushed Slag (ACBF) Crushed Steel Slag ^{1/} Crushed Concrete
HMA High ESAL Low ESAL	Binder IL-19.0 or IL-19.0L SMA Binder	<u>Allowed Alone or in Combination</u> ^{5/ 6/} : Crushed Gravel Carbonate Crushed Stone ^{2/} Crystalline Crushed Stone Crushed Sandstone Crushed Slag (ACBF) Crushed Concrete ^{3/}

Use	Mixture	Aggregates Allowed	
HMA High ESAL Low ESAL	C Surface and Leveling Binder IL-9.5 or IL-9.5L SMA Ndesign 50 Surface	<u>Allowed Alone or in Combination</u> ^{5/} : Crushed Gravel Carbonate Crushed Stone ^{2/} Crystalline Crushed Stone Crushed Sandstone Crushed Slag (ACBF) Crushed Steel Slag ^{4/} Crushed Concrete ^{3/}	
HMA High ESAL	D Surface and Leveling Binder IL-9.5 SMA Ndesign 50 Surface	<u>Allowed Alone or in Combination</u> ^{5/} : Crushed Gravel Carbonate Crushed Stone (other than Limestone) ^{2/} Crystalline Crushed Stone Crushed Sandstone Crushed Slag (ACBF) Crushed Steel Slag ^{4/} Crushed Concrete ^{3/}	
		<u>Other Combinations Allowed:</u>	
		<i>Up to...</i>	<i>With...</i>
		25% Limestone	Dolomite
		50% Limestone	Any Mixture D aggregate other than Dolomite
75% Limestone	Crushed Slag (ACBF) or Crushed Sandstone		
HMA High ESAL	E Surface IL-9.5 SMA Ndesign 80 Surface	<u>Allowed Alone or in Combination</u> ^{5/ 6/} : Crystalline Crushed Stone Crushed Sandstone Crushed Slag (ACBF) Crushed Steel Slag No Limestone.	
		<u>Other Combinations Allowed:</u> <i>Up to...</i>	<i>With...</i>

Use	Mixture	Aggregates Allowed	
		50% Dolomite ^{2/}	Any Mixture E aggregate
		75% Dolomite ^{2/}	Crushed Sandstone, Crushed Slag (ACBF), Crushed Steel Slag, or Crystalline Crushed Stone
		75% Crushed Gravel ^{2/} or Crushed Concrete ^{3/}	Crushed Sandstone, Crystalline Crushed Stone, Crushed Slag (ACBF), or Crushed Steel Slag
HMA High ESAL	F Surface IL-9.5 SMA Ndesign 80 Surface	<u>Allowed Alone or in Combination</u> ^{5/ 6/} :	
		Crystalline Crushed Stone Crushed Sandstone Crushed Slag (ACBF) Crushed Steel Slag No Limestone.	
		<u>Other Combinations Allowed:</u>	
		<i>Up to...</i>	<i>With...</i>
		50% Crushed Gravel ^{2/} , Crushed Concrete ^{3/} , or Dolomite ^{2/}	Crushed Sandstone, Crushed Slag (ACBF), Crushed Steel Slag, or Crystalline Crushed Stone

- 1/ Crushed steel slag allowed in shoulder surface only.
- 2/ Carbonate crushed stone (limestone) and/or crushed gravel shall not be used in SMA Ndesign 80. In SMA Ndesign 50, carbonate crushed stone shall not be blended with any of the other aggregates allowed alone in Ndesign 50 SMA binder or Ndesign 50 SMA surface.
- 3/ Crushed concrete will not be permitted in SMA mixes.
- 4/ Crushed steel slag shall not be used as leveling binder.
- 5/ When combinations of aggregates are used, the blend percent measurements shall be by volume.”
- 6/ Combining different types of aggregate will not be permitted in SMA Ndesign 80.”

GROUND TIRE RUBBER (GTR) MODIFIED ASPHALT BINDER (D-1)

Effective: June 26, 2006

Revised: April 1, 2016

Add the following to the end of article 1032.05 of the Standard Specifications:

“(c) Ground Tire Rubber (GTR) Modified Asphalt Binder. A quantity of 10.0 to 14.0 percent GTR (Note 1) shall be blended by dry unit weight with a PG 64-28 to make a GTR 70-28 or a PG 58-28 to make a GTR 64-28. The base PG 64-28 and PG 58-28 asphalt binders shall meet the requirements of Article 1032.05(a). Compatible polymers may be added during production. The GTR modified asphalt binder shall meet the requirements of the following table.

Test	Asphalt Grade GTR 70-28	Asphalt Grade GTR 64-28
Flash Point (C.O.C.), AASHTO T 48, °F (°C), min.	450 (232)	450 (232)
Rotational Viscosity, AASHTO T 316 @ 275 °F (135 °C), Poises, Pa·s, max.	30 (3)	30 (3)
Softening Point, AASHTO T 53, °F (°C), min.	135 (57)	130 (54)
Elastic Recovery, ASTM D 6084, Procedure A (sieve waived) @ 77 °F, (25 °C), aged, ss, 100 mm elongation, 5 cm/min., cut immediately, %, min.	65	65

Note 1. GTR shall be produced from processing automobile and/or light truck tires by the ambient grinding method. GTR shall not exceed 1/16 in. (2 mm) in any dimension and shall contain no free metal particles or other materials. A mineral powder (such as talc) meeting the requirements of AASHTO M 17 may be added, up to a maximum of four percent by weight of GTR to reduce sticking and caking of the GTR particles. When tested in accordance with Illinois modified AASHTO T 27, a 50 g sample of the GTR shall conform to the following gradation requirements:

Sieve Size	Percent Passing
No. 16 (1.18 mm)	100
No. 30 (600 µm)	95 ± 5
No. 50 (300 µm)	> 20

Add the following to the end of Note 1. of article 1030.03 of the Standard Specifications:

“A dedicated storage tank for the Ground Tire Rubber (GTR) modified asphalt binder shall be provided. This tank must be capable of providing continuous mechanical mixing throughout by continuous agitation and recirculation of the asphalt binder to provide a uniform mixture. The tank shall be heated and capable of maintaining the temperature of the asphalt binder at 300 °F to 350 °F (149 °C to 177 °C). The asphalt binder metering systems of dryer drum plants shall be calibrated with the actual GTR modified asphalt binder material with an accuracy of ± 0.40 percent.”

Revise 1030.02(c) of the Standard Specifications to read:

“(c) RAP Materials (Note 5)1031”

Add the following note to 1030.02 of the Standard Specifications:

Note 5. When using reclaimed asphalt pavement and/or reclaimed asphalt shingles, the maximum asphalt binder replacement percentage shall be according to the most recent special provision for recycled materials.

HMA MIXTURE DESIGN REQUIREMENTS (D-1)

Effective: January 1, 2013
 Revised: January 1, 2018

1) Design Composition and Volumetric Requirements

Revise the table in Article 406.06(d) of the Standard Specifications to read:

“MINIMUM COMPACTED LIFT THICKNESS	
Mixture Composition	Thickness, in. (mm)
IL-4.75	3/4 (19)
SMA-9.5, IL-9.5, IL-9.5L	1 1/2 (38)
SMA-12.5	2 (50)
IL-19.0, IL-19.0L	2 1/4 (57)”

Revise the table in Article 1004.03(c) of the Standard Specifications to read:

“Use	Size/Application	Gradation No.
Class A-1, 2, & 3	3/8 in. (10 mm) Seal	CA 16
Class A-1	1/2 in. (13 mm) Seal	CA 15
Class A-2 & 3	Cover	CA 14
HMA High ESAL	IL-19.0 IL-9.5	CA 11 ^{1/} CA 16, CA 13 ^{3/}
HMA Low ESAL	IL-19.0L IL-9.5L Stabilized Subbase or Shoulders	CA 11 ^{1/} CA 16
SMA ^{2/}	1/2 in. (12.5mm) Binder & Surface IL 9.5 Surface	CA13 ^{3/} , CA14 or CA16 CA16, CA 13 ^{3/}

- 1/ CA 16 or CA 13 may be blended with the gradations listed.
- 2/ The coarse aggregates used shall be capable of being combined with stone sand, slag sand, or steel slag sand meeting the FA/FM 20 gradation and mineral filler to meet the approved mix design and the mix requirements noted herein.
- 3/ CA 13 shall be 100 percent passing the 1/2 in. (12.5mm) sieve.

Revise Article 1004.03(e) of the Supplemental Specifications to read:

“(e) Absorption. For SMA the coarse aggregate shall also have water absorption ≤ 2.0 percent.”

Revise the last paragraph of Article 1102.01 (a) (5) of the Standard Specifications to read:

“IL-4.75 and Stone Matrix Asphalt (SMA) mixtures which contain aggregate having absorptions greater than or equal to 2.0 percent, or which contain steal slag sand, shall have minimum surge bin storage plus haul time of 1.5 hours.”

Revise the nomenclature table in Article 1030.01 of the Standard Specifications to read:

“High ESAL	IL-19.0 binder; IL-9.5 surface; IL-4.75; SMA-12.5, SMA-9.5
Low ESAL	IL-19.0L binder; IL-9.5L surface; Stabilized Subbase (HMA) ^{1/} ; HMA Shoulders ^{2/}

1/ Uses 19.0L binder mix.

2/ Uses 19.0L for lower lifts and 9.5L for surface lift.”

Revise Article 1030.02 of the Standard Specifications and Supplemental Specifications to read:

“**1030.02 Materials.** Materials shall be according to the following.

Item	Article/Section
(a) Coarse Aggregate	1004.03
(b) Fine Aggregate	1003.03
(c) RAP Material	1031
(d) Mineral Filler	1011
(e) Hydrated Lime	1012.01
(f) Slaked Quicklime (Note 1)	
(g) Performance Graded Asphalt Binder (Note 2)	1032
(h) Fibers (Note 3)	
(i) Warm Mix Asphalt (WMA) Technologies (Note 4)	

Note 1. Slaked quicklime shall be according to ASTM C 5.

Note 2. The asphalt binder shall be an SBS PG 76-28 when the SMA is used on a full-depth asphalt pavement and SBS PG 76-22 when used as an overlay, except where modified herein. The asphalt binder shall be an Elvaloy or SBS PG 76-22 for IL-4.75, except where modified herein. The elastic recovery shall be a minimum of 80.

Note 3. A stabilizing additive such as cellulose or mineral fiber shall be added to the SMA mixture according to Illinois Modified AASHTO M 325. The stabilizing additive shall meet the Fiber Quality Requirements listed in Illinois Modified AASHTO M 325. Prior to approval and use of fibers, the Contractor shall submit a notarized certification by the producer of these materials stating they meet these requirements. Reclaimed Asphalt Shingles (RAS) may be used in Stone Matrix Asphalt (SMA) mixtures designed with an SBA polymer modifier as a fiber additive if the mix design with RAS included meets AASHTO T305 requirements. The RAS shall be from a certified source that produces either Type I or Type 2. Material shall meet requirements noted herein and the actual dosage rate will be determined by the Engineer.

Note 4. Warm mix additives or foaming processes shall be selected from the current Bureau of Materials and Physical Research Approved List, “Warm Mix Asphalt Technologies”.”

Revise Article 1030.04(a)(1) of the Standard Specifications and the Supplemental Specifications to read:

“ (1) High ESAL Mixtures. The Job Mix Formula (JMF) shall fall within the following limits.

High ESAL, MIXTURE COMPOSITION (% PASSING) ^{1/}										
Sieve Size	IL-19.0 mm		SMA ^{4/} IL-12.5 mm		SMA ^{4/} IL-9.5 mm		IL-9.5 mm		IL-4.75 mm	
	min	max	min	max	min	max	min	max	min	max
1 1/2 in. (37.5 mm)										
1 in. (25 mm)		100								
3/4 in. (19 mm)	90	100		100						
1/2 in. (12.5 mm)	75	89	80	100		100		100		100
3/8 in. (9.5 mm)				65	90	100	90	100		100
#4 (4.75 mm)	40	60	20	30	36	50	34	69	90	100
#8 (2.36 mm)	20	42	16	24 ^{5/}	16	32 ^{5/}	34 ^{6/}	52 ^{2/}	70	90
#16 (1.18 mm)	15	30					10	32	50	65
#30 (600 μm)			12	16	12	18				
#50 (300 μm)	6	15					4	15	15	30
#100 (150 μm)	4	9					3	10	10	18
#200 (75 μm)	3	6	7.0	9.0 ^{3/}	7.5	9.5 ^{3/}	4	6	7	9 ^{3/}
Ratio Dust/Asphalt Binder		1.0		1.5		1.5		1.0		1.0

1/ Based on percent of total aggregate weight.

- 2/ The mixture composition shall not exceed 44 percent passing the #8 (2.36 mm) sieve for surface courses with Ndesign = 90.
- 3/ Additional minus No. 200 (0.075 mm) material required by the mix design shall be mineral filler, unless otherwise approved by the Engineer.
- 4/ The maximum percent passing the #635 (20 µm) sieve shall be ≤ 3 percent.
- 5/ When establishing the Adjusted Job Mix Formula (AJMF) the percent passing the #8 (2.36 mm) sieve shall not be adjusted above the percentage stated on the table.
- 6/ When establishing the Adjusted Job Mix Formula (AJMF) the percent passing the #8 (2.36 mm) sieve shall not be adjusted below 34 percent.

Revise Article 1030.04(b)(1) of the Standard Specifications to read:

“(1) High ESAL Mixtures. The target value for the air voids of the HMA shall be 4.0 percent and for IL-4.75 it shall be 3.5 percent at the design number of gyrations. The VMA and VFA of the HMA design shall be based on the nominal maximum size of the aggregate in the mix, and shall conform to the following requirements.

VOLUMETRIC REQUIREMENTS High ESAL				
	Voids in the Mineral Aggregate (VMA), % minimum			Voids Filled with Asphalt Binder (VFA), %
Ndesign	IL-19.0	IL-9.5	IL-4.75 ^{1/}	
50	13.5	15.0	18.5	65 – 78 ^{2/}
70				
90				

1/ Maximum Draindown for IL-4.75 shall be 0.3 percent

2/ VFA for IL-4.75 shall be 72-85 percent”

Replace Article 1030.04(b)(3) of the Standard Specifications with the following:

“(3) SMA Mixtures.

Volumetric Requirements SMA ^{1/}			
Ndesign	Design Air Voids Target %	Voids in the Mineral Aggregate (VMA), % min.	Voids Filled with Asphalt (VFA), %
80 ^{4/}	3.5	17.0 ^{2/}	75 - 83
		16.0 ^{3/}	

- 1/ Maximum draindown shall be 0.3 percent. The draindown shall be determined at the JMF asphalt binder content at the mixing temperature plus 30 °F.
- 2/ Applies when specific gravity of coarse aggregate is ≥ 2.760 .
- 3/ Applies when specific gravity of coarse aggregate is < 2.760 .
- 4/ Blending of different types of aggregate will not be permitted. For surface course, the coarse aggregate can be crushed steel slag, crystalline crushed stone or crushed sandstone. For binder course, coarse aggregate shall be crushed stone (dolomite), crushed gravel, crystalline crushed stone, or crushed sandstone.

Add to the end of Article 1030.05 (d) (2) a. of the Standard Specifications:

“During production, the Contractor shall test SMA mixtures for draindown according to AASHTO T305 at a frequency of 1 per day of production.”

Delete last sentence of the second paragraph of Article 1102.01(a) (4) b. 2.

Add to the end of Article 1102.01 (a) (4) b. 2.:

“As an option, collected dust (baghouse) may be used in lieu of manufactured mineral filler according to the following:

- (a.) Sufficient collected dust (baghouse) is available for production of the SMA mix for the entire project.
- (b.) A mix design was prepared based on collected dust (baghouse).

2) Design Verification and Production

Revise Article 1030.04 (d) of the Standard Specifications to read:

“(d) Verification Testing. High ESAL, IL-4.75, and SMA mix designs submitted for verification will be tested to ensure that the resulting mix designs will pass the required criteria for the Hamburg Wheel Test (IL mod AASHTO T-324) and the Tensile Strength Test (IL mod AASHTO T-283). The Department will perform a verification test on gyratory specimens compacted by the Contractor. If the mix fails the Department’s verification test, the Contractor shall make the necessary changes to the mix and resubmit compacted specimens to the Department for verification. If the mix fails again, the mix design will be rejected.

All new and renewal mix designs will be required to be tested, prior to submittal for Department verification and shall meet the following requirements:

- (1) Hamburg Wheel Test criteria. The maximum allowable rut depth shall be 0.5 in. (12.5 mm). The minimum number of wheel passes at the 0.5 in. (12.5 mm) rut depth criteria shall be based on the high temperature binder grade of the mix as specified in the mix requirements table of the plans.

Illinois Modified AASHTO T 324 Requirements ^{1/}

Asphalt Binder Grade	# Repetitions	Max Rut Depth (mm)
PG 70 -XX (or higher)	20,000	12.5
PG 64 -XX (or lower)	10,000	12.5

- 1/ When produced at temperatures of 275 ± 5 °F (135 ± 3 °C) or less, loose Warm Mix Asphalt shall be oven aged at 270 ± 5 °F (132 ± 3 °C) for two hours prior to gyratory compaction of Hamburg Wheel specimens.

Note: For SMA Designs (N-80) the maximum rut depth is 6.0 mm at 20,000 repetitions.
 For IL 4.75mm Designs (N-50) the maximum rut depth is 9.0mm at 15,000 repetitions.

- (2) Tensile Strength Criteria. The minimum allowable conditioned tensile strength shall be 60 psi (415 kPa) for non-polymer modified performance graded (PG) asphalt binder and 80 psi (550 kPa) for polymer modified PG asphalt binder. The maximum allowable unconditioned tensile strength shall be 200 psi (1380 kPa).”

Production Testing. Revise first paragraph of Article 1030.06(a) of the Standard Specifications to read:

- “(a) High ESAL, IL-4.75, WMA, and SMA Mixtures. For each contract, a 300 ton (275 metric tons) test strip, except for SMA mixtures it will be 400 ton (363 metric ton), will be required at the beginning of HMA production for each mixture at the beginning of

each construction year according to the Manual of Test Procedures for Materials “Hot Mix Asphalt Test Strip Procedures”. At the request of the Producer, the Engineer may waive the test strip if previous construction during the current construction year has demonstrated the constructability of the mix using Department test results.”

Add the following after the sixth paragraph in Article 1030.06 (a) of the Standard Specifications:

“The Hamburg Wheel test shall also be conducted on all HMA mixtures from a sample taken within the first 500 tons (450 metric tons) on the first day of production or during start up with a split reserved for the Department. The mix sample shall be tested according to the Illinois Modified AASHTO T 324 and shall meet the requirements specified herein. Mix production shall not exceed 1500 tons (1350 metric tons) or one day’s production, whichever comes first, until the testing is completed and the mixture is found to be in conformance. The requirement to cease mix production may be waived if the plant produced mixture demonstrates conformance prior to start of mix production for a contract. If the mixture fails to meet the Hamburg Wheel criteria, no further mixture will be accepted until the Contractor takes such action as is necessary to furnish a mixture meeting the criteria”

Method of Measurement:

Add the following after the fourth paragraph of Article 406.13 (b):

“The plan quantities of SMA mixtures shall be adjusted using the actual approved binder and surface Mix Design’s G_{mb} .”

Basis of Payment.

Replace the fourth paragraph of Article 406.14 of the Standard Specifications with the following:

“Stone matrix asphalt will be paid for at the contract unit price per ton (metric ton) for POLYMERIZED HOT-MIX ASPHALT SURFACE COURSE, STONE MATRIX ASPHALT, of the mixture composition and Ndesign specified; and POLYMERIZED HOT-MIX ASPHALT BINDER COURSE, STONE MATRIX ASPHALT, of the mixture composition and Ndesign specified.”

MAINTENANCE OF ROADWAYS (D-1)

Effective: September 30, 1985

Revised: November 1, 1996

Beginning on the date that work begins on this project, the Contractor shall assume responsibility for normal maintenance of all existing roadways within the limits of the improvement. This normal maintenance shall include all repair work deemed necessary by the Engineer, but shall not include snow removal operations. Traffic control and protection for maintenance of roadways will be provided by the Contractor as required by the Engineer.

If items of work have not been provided in the contract, or otherwise specified for payment, such items, including the accompanying traffic control and protection required by the Engineer, will be paid for in accordance with Article 109.04 of the Standard Specifications.

RECLAIMED ASPHALT PAVEMENT AND RECLAIMED ASPHALT SHINGLES (D-1)

Effective: November 1, 2012

Revise: January 1, 2018

Revise Section 1031 of the Standard Specifications to read:

“SECTION 1031. RECLAIMED ASPHALT PAVEMENT AND RECLAIMED ASPHALT SHINGLES

1031.01 Description. Reclaimed asphalt pavement and reclaimed asphalt shingles shall be according to the following.

- (a) Reclaimed Asphalt Pavement (RAP). RAP is the material resulting from cold milling or crushing an existing hot-mix asphalt (HMA) pavement. RAP will be considered processed FRAP after completion of both crushing and screening to size. The Contractor shall supply written documentation that the RAP originated from routes or airfields under federal, state, or local agency jurisdiction.
- (b) Reclaimed Asphalt Shingles (RAS). Reclaimed asphalt shingles (RAS). RAS is from the processing and grinding of preconsumer or post-consumer shingles. RAS shall be a clean and uniform material with a maximum of 0.5 percent unacceptable material, as defined in Central Bureau of Materials Policy Memorandum, “Reclaimed Asphalt Shingle (RAS) Sources”, by weight of RAS. All RAS used shall come from a Central Bureau of Materials approved processing facility where it shall be ground and processed to 100 percent passing the 3/8 in. (9.5 mm) sieve and 90 percent passing the #4 (4.75 mm) sieve. RAS shall meet the testing requirements specified herein. In addition, RAS shall meet the following Type 1 or Type 2 requirements.
 - (1) Type 1. Type 1 RAS shall be processed, preconsumer asphalt shingles salvaged from the manufacture of residential asphalt roofing shingles.
 - (2) Type 2. Type 2 RAS shall be processed post-consumer shingles only, salvaged from residential, or four unit or less dwellings not subject to the National Emission Standards for Hazardous Air Pollutants (NESHAP).

1031.02 Stockpiles. RAP and RAS stockpiles shall be according to the following.

- (a) RAP Stockpiles. The Contractor shall construct individual, sealed RAP stockpiles meeting one of the following definitions. Additional processed RAP (FRAP) shall be stockpiled in a separate working pile, as designated in the QC Plan, and only added to the sealed stockpile when test results for the working pile are complete and are found to meet tolerances specified herein for the original sealed FRAP stockpile. Stockpiles shall be sufficiently separated to prevent intermingling at the base. All stockpiles (including

unprocessed RAP and FRAP) shall be identified by signs indicating the type as listed below (i.e. “Non- Quality, FRAP -#4 or Type 2 RAS”, etc...).

- (1) Fractionated RAP (FRAP). FRAP shall consist of RAP from Class I, HMA (High and Low ESAL) or equivalent mixtures. The coarse aggregate in FRAP shall be crushed aggregate and may represent more than one aggregate type and/or quality, but shall be at least C quality. All FRAP shall be processed prior to testing and sized into fractions with the separation occurring on or between the #4 (4.75 mm) and 1/2 in. (12.5 mm) sieves. Agglomerations shall be minimized such that 100 percent of the RAP in the coarse fraction shall pass the maximum sieve size specified for the mix the FRAP will be used in.
- (2) Restricted FRAP (B quality) stockpiles shall consist of RAP from Class I, HMA (High ESAL), or HMA (High ESAL). If approved by the Engineer, the aggregate from a maximum 3.0 in. (75 mm) single combined pass of surface/binder milling will be classified as B quality. All millings from this application will be processed into FRAP as described previously.
- (3) Conglomerate. Conglomerate RAP stockpiles shall consist of RAP from Class I, HMA (High and Low ESAL) or equivalent mixtures. The coarse aggregate in this RAP shall be crushed aggregate and may represent more than one aggregate type and/or quality, but shall be at least C quality. This RAP may have an inconsistent gradation and/or asphalt binder content prior to processing. All conglomerate RAP shall be processed (FRAP) prior to testing. Conglomerate RAP stockpiles shall not contain steel slag or other expansive material as determined by the Department.
- (4) Conglomerate “D” Quality (DQ). Conglomerate DQ RAP stockpiles shall consist of RAP from HMA shoulders, bituminous stabilized subbases or HMA (Low ESAL)/HMA (Low ESAL) IL-19.0L binder mixture. The coarse aggregate in this RAP may be crushed or round but shall be at least D quality. This RAP may have an inconsistent gradation and/or asphalt binder content. Conglomerate DQ RAP stockpiles shall not contain steel slag or other expansive material as determined by the Department.
- (5) Non-Quality. RAP stockpiles that do not meet the requirements of the stockpile categories listed above shall be classified as “Non-Quality”.

RAP or FRAP containing contaminants, such as earth, brick, sand, concrete, sheet asphalt, bituminous surface treatment (i.e. chip seal), pavement fabric, joint sealants, plant cleanout etc., will be unacceptable unless the contaminants are removed to the satisfaction of the Engineer. Sheet asphalt shall be stockpiled separately.

- (b) RAS Stockpiles. Type 1 and Type 2 RAS shall be stockpiled separately and shall be sufficiently separated to prevent intermingling at the base. Each stockpile shall be signed indicating what type of RAS is present.

However, a RAS source may submit a written request to the Department for approval to blend mechanically a specified ratio of Type 1 RAS with Type 2 RAS. The source will not be permitted to change the ratio of the blend without the Department prior written approval. The Engineer's written approval will be required, to mechanically blend RAS with any fine aggregate produced under the AGCS, up to an equal weight of RAS, to improve workability. The fine aggregate shall be "B Quality" or better from an approved Aggregate Gradation Control System source. The fine aggregate shall be one that is approved for use in the HMA mixture and accounted for in the mix design and during HMA production.

Records identifying the shingle processing facility supplying the RAS, RAS type, and lot number shall be maintained by project contract number and kept for a minimum of three years.

1031.03 Testing. FRAP and RAS testing shall be according to the following.

- (a) FRAP Testing. When used in HMA, the FRAP shall be sampled and tested either during processing or after stockpiling. It shall also be sampled during HMA production.
 - (1) During Stockpiling. For testing during stockpiling, washed extraction samples shall be run at the minimum frequency of one sample per 500 tons (450 metric tons) for the first 2000 tons (1800 metric tons) and one sample per 2000 tons (1800 metric tons) thereafter. A minimum of five tests shall be required for stockpiles less than 4000 tons (3600 metric tons).
 - (2) Incoming Material. For testing as incoming material, washed extraction samples shall be run at a minimum frequency of one sample per 2000 tons (1800 metric tons) or once per week, whichever comes first.
 - (3) After Stockpiling. For testing after stockpiling, the Contractor shall submit a plan for approval to the District proposing a satisfactory method of sampling and testing the RAP/FRAP pile either in-situ or by restocking. The sampling plan shall meet the minimum frequency required above and detail the procedure used to obtain representative samples throughout the pile for testing.

Before extraction, each field sample of FRAP, shall be split to obtain two samples of test sample size. One of the two test samples from the final split shall be labeled and stored for Department use. The Contractor shall extract the other test sample according to Department procedure. The Engineer reserves the right to test any sample (split or Department-taken) to verify Contractor test results.

- (b) RAS Testing. RAS shall be sampled and tested during stockpiling according to Central Bureau of Materials Policy Memorandum, "Reclaimed Asphalt Shingle (RAS) Sources". The Contractor shall also sample as incoming material at the HMA plant.

- (1) During Stockpiling. Washed extraction and testing for unacceptable materials shall be run at the minimum frequency of one sample per 200 tons (180 metric tons) for the first 1000 tons (900 metric tons) and one sample per 1000 tons (900 metric tons) thereafter. A minimum of five samples are required for stockpiles less than 1000 tons (900 metric tons). Once a ≤ 1000 ton (900 metric ton), five-sample/test stockpile has been established it shall be sealed. Additional incoming RAS shall be in a separate working pile as designated in the Quality Control plan and only added to the sealed stockpile when the test results of the working pile are complete and are found to meet the tolerances specified herein for the original sealed RAS stockpile.
- (2) Incoming Material. For testing as incoming material at the HMA plant, washed extraction shall be run at the minimum frequency of one sample per 250 tons (227 metric tons). A minimum of five samples are required for stockpiles less than 1000 tons (900 metric tons). The incoming material test results shall meet the tolerances specified herein.

The Contractor shall obtain and make available all test results from start of the initial stockpile sampled and tested at the shingle processing facility in accordance with the facility's QC Plan.

Before extraction, each field sample shall be split to obtain two samples of test sample size. One of the two test samples from the final split shall be labeled and stored for Department use. The Contractor shall extract the other test sample according to Department procedures. The Engineer reserves the right to test any sample (split or Department-taken) to verify Contractor test results.

1031.04 Evaluation of Tests. Evaluation of test results shall be according to the following.

- (a) Evaluation of FRAP Test Results. All test results shall be compiled to include asphalt binder content, gradation and, when applicable (for slag), G_{mm} . A five test average of results from the original pile will be used in the mix designs. Individual extraction test results run thereafter, shall be compared to the average used for the mix design, and will be accepted if within the tolerances listed below.

Parameter	FRAP
No. 4 (4.75 mm)	$\pm 6 \%$
No. 8 (2.36 mm)	$\pm 5 \%$
No. 30 (600 μm)	$\pm 5 \%$
No. 200 (75 μm)	$\pm 2.0 \%$
Asphalt Binder	$\pm 0.3 \%$
G_{mm}	± 0.03 ^{1/}

- 1/ For stockpile with slag or steel slag present as determined in the current Manual of Test Procedures Appendix B 21, "Determination of Reclaimed Asphalt Pavement Aggregate Bulk Specific Gravity".

If any individual sieve and/or asphalt binder content tests are out of the above tolerances when compared to the average used for the mix design, the FRAP stockpile shall not be used in Hot-Mix Asphalt unless the FRAP representing those tests is removed from the stockpile. All test data and acceptance ranges shall be sent to the District for evaluation.

The Contractor shall maintain a representative moving average of five tests to be used for Hot-Mix Asphalt production.

With the approval of the Engineer, the ignition oven may be substituted for extractions according to the ITP, "Calibration of the Ignition Oven for the Purpose of Characterizing Reclaimed Asphalt Pavement (RAP)" or Illinois Modified AASHTO T-164-11, Test Method A.

- (b) Evaluation of RAS Test Results. All of the test results, with the exception of percent unacceptable materials, shall be compiled and averaged for asphalt binder content and gradation. A five test average of results from the original pile will be used in the mix designs. Individual test results run thereafter, when compared to the average used for the mix design, will be accepted if within the tolerances listed below.

Parameter	RAS
No. 8 (2.36 mm)	± 5 %
No. 16 (1.18 mm)	± 5 %
No. 30 (600 µm)	± 4 %
No. 200 (75 µm)	± 2.5 %
Asphalt Binder Content	± 2.0 %

If any individual sieve and/or asphalt binder content tests are out of the above tolerances when compared to the average used for the mix design, the RAS shall not be used in Hot-Mix Asphalt unless the RAS representing those tests is removed from the stockpile. All test data and acceptance ranges shall be sent to the District for evaluation.

- (c) Quality Assurance by the Engineer. The Engineer may witness the sampling and splitting conduct assurance tests on split samples taken by the Contractor for quality control testing a minimum of once a month.

The overall testing frequency will be performed over the entire range of Contractor samples for asphalt binder content and gradation. The Engineer may select any or all split samples for assurance testing. The test results will be made available to the Contractor as soon as they become available.

The Engineer will notify the Contractor of observed deficiencies.

Differences between the Contractor's and the Engineer's split sample test results will be considered acceptable if within the following limits.

Test Parameter	Acceptable Limits of Precision	
	FRAP	RAS
% Passing: ^{1/}		
1/2 in.	5.0%	
No. 4	5.0%	
No. 8	3.0%	4.0%
No. 30	2.0%	4.0%
No. 200	2.2%	4.0%
Asphalt Binder Content	0.3%	3.0%
G _{mm}	0.030	

1/ Based on washed extraction.

In the event comparisons are outside the above acceptable limits of precision, the Engineer will immediately investigate.

- (d) Acceptance by the Engineer. Acceptable of the material will be based on the validation of the Contractor's quality control by the assurance process.

1031.05 Quality Designation of Aggregate in RAP and FRAP.

- (a) RAP. The aggregate quality of the RAP for homogeneous, conglomerate, and conglomerate "D" quality stockpiles shall be set by the lowest quality of coarse aggregate in the RAP stockpile and are designated as follows.

- (1) RAP from Class I, HMA (High ESAL), or (Low ESAL) IL-9.5L surface mixtures are designated as containing Class B quality coarse aggregate.
- (2) RAP from HMA (Low ESAL) IL-19.0L binder mixture is designated as Class D quality coarse aggregate.
- (3) RAP from Class I, HMA (High ESAL) binder mixtures, bituminous base course mixtures, and bituminous base course widening mixtures are designated as containing Class C quality coarse aggregate.
- (4) RAP from bituminous stabilized subbase and BAM shoulders are designated as containing Class D quality coarse aggregate.

- (b) FRAP. If the Engineer has documentation of the quality of the FRAP aggregate, the Contractor shall use the assigned quality provided by the Engineer.

If the quality is not known, the quality shall be determined as follows. Fractionated RAP stockpiles containing plus #4 (4.75 mm) sieve coarse aggregate shall have a maximum tonnage of 5,000 tons (4,500 metric tons). The Contractor shall obtain a representative sample witnessed by the Engineer. The sample shall be a minimum of 50 lb (25 kg). The sample shall be extracted according to Illinois Modified AASHTO T 164 by a consultant laboratory prequalified by the Department for the specified testing. The consultant laboratory shall submit the test results along with the recovered aggregate to the District Office. The cost for this testing shall be paid by the Contractor. The District will forward the sample to the Central Bureau of Materials Aggregate Lab for MicroDeval Testing, according to ITP 327. A maximum loss of 15.0 percent will be applied for all HMA applications. The fine aggregate portion of the fractionated RAP shall not be used in any HMA mixtures that require a minimum of "B" quality aggregate or better, until the coarse aggregate fraction has been determined to be acceptable thru a MicroDeval Testing.

1031.06 Use of FRAP and/or RAS in HMA. The use of FRAP and/or RAS shall be the Contractor's option when constructing HMA in all contracts.

(a) FRAP. The use of FRAP in HMA shall be as follows.

- (1) Coarse Aggregate Size (after extraction). The coarse aggregate in all FRAP shall be equal to or less than the nominal maximum size requirement for the HMA mixture to be produced.
- (2) Steel Slag Stockpiles. FRAP stockpiles containing steel slag or other expansive material, as determined by the Department, shall be homogeneous and will be approved for use in HMA (High ESAL and Low ESAL) mixtures regardless of lift or mix type.
- (3) Use in HMA Surface Mixtures (High and Low ESAL). FRAP stockpiles for use in HMA surface mixtures (High and Low ESAL) shall have coarse aggregate that is Class B quality or better. FRAP shall be considered equivalent to limestone for frictional considerations unless produced/screened to minus 3/8 inch.
- (4) Use in HMA Binder Mixtures (High and Low ESAL), HMA Base Course, and HMA Base Course Widening. FRAP stockpiles for use in HMA binder mixtures (High and Low ESAL), HMA base course, and HMA base course widening shall be FRAP in which the coarse aggregate is Class C quality or better.
- (5) Use in Shoulders and Subbase. FRAP stockpiles for use in HMA shoulders and stabilized subbase (HMA) shall be FRAP, Restricted FRAP, conglomerate, or conglomerate DQ.

- (b) RAS. RAS meeting Type 1 or Type 2 requirements will be permitted in all HMA applications as specified herein.
- (c) FRAP and/or RAS Usage Limits. Type 1 or Type 2 RAS may be used alone or in conjunction with FRAP in HMA mixtures up to a maximum of 5.0 percent by weight of the total mix.

When FRAP is used alone or FRAP is used in conjunction with RAS, the percent of virgin asphalt binder replacement (ABR) shall not exceed the amounts indicated in the table below for a given N Design.

Max Asphalt Binder Replacement for FRAP with RAS Combination

HMA Mixtures ^{1/ 2/ 4/}	Maximum % ABR		
	Binder/Leveling Binder	Surface	Polymer Modified ^{3/}
30L	50	40	30
50	40	35	30
70	40	30	30
90	40	30	30
4.75 mm N-50			40
SMA N-80			30

- 1/ For Low ESAL HMA shoulder and stabilized subbase, the percent asphalt binder replacement shall not exceed 50 % of the total asphalt binder in the mixture.
- 2/ When the binder replacement exceeds 15 % for all mixes, except for SMA and IL-4.75, the high and low virgin asphalt binder grades shall each be reduced by one grade (i.e. 25 % binder replacement using a virgin asphalt binder grade of PG64-22 will be reduced to a PG58-28). When constructing full depth HMA and the ABR is less than 15 %, the required virgin asphalt binder grade shall be PG64-28.
- 3/ When the ABR for SMA or IL-4.75 is 15 % or less, the required virgin asphalt binder shall be SBS PG76-22 and the elastic recovery shall be a minimum of 80. When the ABR for SMA or IL-4.75 exceeds 15%, the virgin asphalt binder grade shall be SBS PG70-28 and the elastic recovery shall be a minimum of 80.
- 4/ When FRAP or RAS is used alone, the maximum percent asphalt binder replacement designated on the table shall be reduced by 10 %.

1031.07 HMA Mix Designs. At the Contractor's option, HMA mixtures may be constructed utilizing RAP/FRAP and/or RAS material meeting the detailed requirements specified herein.

- (a) FRAP and/or RAS. FRAP and /or RAS mix designs shall be submitted for verification. If additional FRAP or RAS stockpiles are tested and found to be within tolerance, as defined under "Evaluation of Tests" herein, and meet all requirements herein, the additional FRAP or RAS stockpiles may be used in the original design at the percent previously verified.
- (b) RAS. Type 1 and Type 2 RAS are not interchangeable in a mix design.

The RAP, FRAP and RAS stone specific gravities (G_{sb}) shall be according to the "Determination of Aggregate Bulk (Dry) Specific Gravity (G_{sb}) or Reclaimed Asphalt Pavement (RAP) and Reclaimed Asphalt Shingles (RAS)" procedure in the Department's Manual of Test Procedures for Materials.

1031.08 HMA Production. HMA production utilizing FRAP and/or RAS shall be as follows.

To remove or reduce agglomerated material, a scalping screen, gator, crushing unit, or comparable sizing device approved by the Engineer shall be used in the RAS and FRAP feed system to remove or reduce oversized material. .

If during mix production, corrective actions fail to maintain FRAP, RAS or QC/QA test results within control tolerances or the requirements listed herein the Contractor shall cease production of the mixture containing FRAP or RAS and conduct an investigation that may require a new mix design.

- (a) RAS. RAS shall be incorporated into the HMA mixture either by a separate weight depletion system or by using the RAP weigh belt. Either feed system shall be interlocked with the aggregate feed or weigh system to maintain correct proportions for all rates of production and batch sizes. The portion of RAS shall be controlled accurately to within ± 0.5 percent of the amount of RAS utilized. When using the weight depletion system, flow indicators or sensing devices shall be provided and interlocked with the plant controls such that the mixture production is halted when RAS flow is interrupted.
- (b) HMA Plant Requirements. HMA plants utilizing FRAP and/or RAS shall be capable of automatically recording and printing the following information.

(1) Dryer Drum Plants.

- a. Date, month, year, and time to the nearest minute for each print.
- b. HMA mix number assigned by the Department.

- c. Accumulated weight of dry aggregate (combined or individual) in tons (metric tons) to the nearest 0.1 ton (0.1 metric ton).
 - d. Accumulated dry weight of RAS and FRAP in tons (metric tons) to the nearest 0.1 ton (0.1 metric ton).
 - e. Accumulated mineral filler in revolutions, tons (metric tons), etc. to the nearest 0.1 unit.
 - f. Accumulated asphalt binder in gallons (liters), tons (metric tons), etc. to the nearest 0.1 unit.
 - g. Residual asphalt binder in the RAS and FRAP material as a percent of the total mix to the nearest 0.1 percent.
 - h. Aggregate RAS and FRAP moisture compensators in percent as set on the control panel. (Required when accumulated or individual aggregate and RAS and FRAP are printed in wet condition.)
 - i. When producing mixtures with FRAP and/or RAS, a positive dust control system shall be utilized.
 - j. Accumulated mixture tonnage.
 - k. Dust Removed (accumulated to the nearest 0.1 ton (0.1 metric ton))
- (2) Batch Plants.
- a. Date, month, year, and time to the nearest minute for each print.
 - b. HMA mix number assigned by the Department.
 - c. Individual virgin aggregate hot bin batch weights to the nearest pound (kilogram).
 - d. Mineral filler weight to the nearest pound (kilogram).
 - f. RAS and FRAP weight to the nearest pound (kilogram).
 - g. Virgin asphalt binder weight to the nearest pound (kilogram).
 - h. Residual asphalt binder in the RAS and FRAP material as a percent of the total mix to the nearest 0.1 percent.

The printouts shall be maintained in a file at the plant for a minimum of one year or as directed by the Engineer and shall be made available upon request. The printing system

will be inspected by the Engineer prior to production and verified at the beginning of each construction season thereafter.

1031.09 RAP in Aggregate Surface Course and Aggregate Wedge Shoulders, Type B.

The use of RAP or FRAP in aggregate surface course and aggregate shoulders shall be as follows.

- (a) Stockpiles and Testing. RAP stockpiles may be any of those listed in Article 1031.02, except “Non-Quality” and “FRAP”. The testing requirements of Article 1031.03 shall not apply. RAP used shall be according to the current Central Bureau of Materials Policy Memorandum, “Reclaimed Asphalt Pavement (RAP) for Aggregate Applications”.
- (b) Gradation. The RAP material shall meet the gradation requirements for CA 6 according to Article 1004.01(c), except the requirements for the minus No. 200 (75 μ m) sieve shall not apply. The sample for the RAP material shall be air dried to constant weight prior to being tested for gradation.”

STATUS OF UTILITIES (D-1)

Effective: June 1, 2016

Utility companies and/or municipal owners located within the construction limits of this project have provided the following information in regard to their facilities and the proposed improvements. The tables below contain a description of specific conflicts to be resolved and/or facilities which will require some action on the part of the Department's contractor to proceed with work. Each table entry includes an identification of the action necessary and, if applicable, the estimated duration required for the resolution.

UTILITIES TO BE ADJUSTED

Conflicts noted below have been identified by following the suggested staging plan included in the contract. The company has been notified of all conflicts and will be required to obtain the necessary permits to complete their work; in some instances resolution will be a function of the construction staging. The responsible agency must relocate or complete new installations as noted in the action column; this work has been deemed necessary to be complete for the Department's contractor to then work in the stage under which the item has been listed.

Pre-Stage

STAGE / LOCATION	TYPE	DESCRIPTION	RESPONSIBLE AGENCY	ACTION
Weiland Road, 75+23, 91' LT to 75+64, 46' LT	4" Gas Line	EX gas line is located underneath PR sidewalk and 1.5' cut.	North Shore Gas	RELOCATION required 2 days
Weiland Road, 75+70, 52' LT	Electric Utility Pole	EX pole is within PR sidewalk.	ComEd	RELOCATION required 1 day
Weiland Road, 78+39 to 79+85, 50' RT	6" Gas Line	EX gas line is located underneath PR sidewalk, driveway, and 0.75' cut.	North Shore Gas	RELOCATION required 1 day
Weiland Road, 78+80, 48' LT	Electric UG Cable	EX UG cable crosses PR driveway that is being lowered by 1'.	ComEd	RELOCATION required 1 day

Weiland Road, 79+45, 35' LT	Cable TV UG Cable	EX UG cable is in potential conflict with EX catch basin.	Comcast	RELOCATION required 1 day
Weiland Road, 79+48	Cable TV UG Cable	EX UG cable crosses roadway that is being lowered by 1'.	Comcast	RELOCATION required 1 day
Weiland Road, 79+51, 39' RT	Electric Utility Pole	EX pole is located on top of PR storm sewer.	ComEd	RELOCATION required 1 day
Weiland Road, 79+56	2" Gas Line	EX gas line crosses PR roadway that is being lowered by 1'.	North Shore Gas	RELOCATION required 1 day
Weiland Road, 79+85 to 83+90, 45' RT	4" Gas Line	EX gas line is located underneath PR curb and gutter and roadway.	North Shore Gas	RELOCATION required 4 days
Weiland Road, 80+15, 38' LT	Electric Utility Pole	EX pole is within PR aggregate improvement.	ComEd	RELOCATION required 1 day
Weiland Road, 80+41, 39' RT	Electric Utility Pole	EX pole is within excavation for PR storm sewer.	ComEd	RELOCATION required 1 day
Weiland Road, 80+92, 35' RT	4" Gas Main	Ex gas main crosses PR catch basin	North Shore Gas	RELOCATION required 1 day
Weiland Road, 81+15, 39' RT	Electric Utility Pole	EX pole conflicts with PR light pole.	ComEd	RELOCATION required 1 day
Weiland Road, 81+72, 36' RT	30" Gas Main	EX gas main crosses PR storm sewer.	North Shore Gas	RELOCATION required 2 days

Weiland Road, 81+74, 41' LT	Telephone UG Cable	EX UG cable crosses PR storm sewer.	AT&T	RELOCATION required 1 day
Weiland Road, 82+49, 42' RT	Electric Utility Pole	EX pole is located within PR curb and gutter.	ComEd	RELOCATION required 1 day
Weiland Road, 82+80, 46' LT	Telephone Pedestal	EX pedestal is located within clear zone of PR multi- used path.	AT&T	RELOCATION required 3 days
Weiland Road, 83+90, 45' RT	4" Gas Line	EX gas line crosses PR storm sewer.	North Shore Gas	RELOCATION required 2 days
Weiland Road, 84+70, 44' RT	Telephone UG Cable	EX UG cable crosses PR storm sewer.	AT&T	RELOCATION required 2 days
Weiland Road, 84+73, 39' LT	Telephone UG Cable	PR light pole is located on the top of EX UG cable.	AT&T	RELOCATION required 1 day
Weiland Road, 86+22	Electric UG Cable	EX UG cable crosses roadway that is being lowered by 1.8'.	ComEd	RELOCATION required 1 day
Weiland Road, 86+97 to 89+02, 34' LT	Telephone UG Cable	EX UG cable is located under PR curb and gutter.	AT&T	RELOCATION required 1 day
Weiland Road, 88+50 to 89+23, 38' RT	4" Gas Line	EX gas line is located in PR aggregate improvement.	North Shore Gas	RELOCATION required 2 days
Weiland Road, 88+98, 47' RT	Electric Utility Pole	EX pole is located within PR sidewalk.	ComEd	RELOCATION required 1 day

Weiland Road, 89+05, 28' RT	Telephone UG Cable	EX UG cable crosses PR storm sewer.	AT&T	RELOCATION required 1 day
Weiland Road, 90+50, 41' RT	4" Gas Line	EX gas line crosses PR manhole.	North Shore Gas	RELOCATION required 1 day
Weiland Road, 91+96, 36' RT to 102+14, 46' RT	4" Gas Line	EX gas line is located underneath PR curb and gutter and roadway.	North Shore Gas	RELOCATION required 5 days
Weiland Road, 92+17, 36' RT	4" Gas Line	EX gas line crosses PR catch basin.	North Shore Gas	RELOCATION required 1 day
Weiland Road, 92+79, 34' RT	Gas Valve	EX valve is located within PR roadway.	North Shore Gas	RELOCATION required 1 day
Weiland Road, 92+80, 47' RT	4" Gas Line	EX gas line crosses PR manhole.	North Shore Gas	RELOCATION required 1 day
Weiland Road, 92+95 to 93+70, 49' RT	Electric UG Cable	EX cable is underneath PR driveway that is being lowered by 1'.	ComEd	RELOCATION required 1 day
Weiland Road, 92+95 to 93+70, 62' RT	Electric UG Cable	EX cable is underneath PR driveway that is being lowered by 1'.	ComEd	RELOCATION required 1 day
Weiland Road, 92+95 to 93+70, 74' RT	Electric UG Cable	EX cable is underneath PR driveway that is being lowered by 1'.	ComEd	RELOCATION required 1 day
Weiland Road, 93+09, 56' RT	UG Fiber Optic Cable	EX UG fiber optic cable crosses PR manhole.	Unite Private Networks	RELOCATION required 1 day

Weiland Road, 93+10, 53' RT	Cable TV UG Cable	EX UG cable crosses PR storm sewer.	Comcast	RELOCATION required 1 day
Weiland Road, 93+60, 64' RT	Telephone UG Cable	EX UG cable crosses PR storm sewer.	AT&T	RELOCATION required 1 day
Weiland Road, 93+72, 59' RT	Telephone UG Cable	EX UG cable crosses PR storm sewer.	AT&T	RELOCATION required 1 day
Weiland Road, 93+75, 59' RT	Telephone Pedestal	EX pedestal is in conflict with PR storm sewer.	AT&T	RELOCATION required 3 day
Weiland Road, 95+75, 42' RT	Cable TV UG Cable	EX UG cable crosses PR manhole.	Comcast	RELOCATION required 1 day
Weiland Road, 95+75, 42' RT	Electric UG Cable	EX UG cable crosses PR manhole.	ComEd	RELOCATION required 1 day
Weiland Road, 96+43, 41' RT	Cable TV UG Cable	EX UG cable crosses PR storm sewer.	Comcast	RELOCATION required 1 day
Weiland Road, 96+43, 42' RT	UG Fiber Optic Cable	EX UG fiber optic cable crosses PR manhole.	Unite Private Networks	RELOCATION required 1 day
Weiland Road, 96+64, 43' LT	Telephone UG Cable	EX UG cable crosses PR storm sewer.	AT&T	RELOCATION required 1 day
Weiland Road, 96+95, 40' LT	Telephone Pedestal	EX pedestal is located near edge of expanded road.	AT&T	RELOCATION required 3 day

Weiland Road, 97+33, 38' RT	Electric Utility Pole	EX pole is within PR aggregate improvement.	ComEd	RELOCATION required 1 day
Weiland Road, 98+93, 38' RT	Electric Utility Pole	EX pole is located near PR aggregate improvement.	ComEd	RELOCATION required 1 day
Weiland Road, 100+40, 40' RT	Electric UG Cable	EX UG cable crosses PR manhole.	ComEd	RELOCATION required 1 day
Weiland Road, 101+27, 48' RT	Electric Utility Pole	EX pole is located within PR roadway.	ComEd	RELOCATION required 1 day
Weiland Road, 104+50, 43' RT	Electric UG Cable	EX UG cable crosses PR manhole.	ComEd	RELOCATION required 1 day
Weiland Road, 107+00 to 109+22, 55' RT	Electric UG Cable	EX UG cable is located within tie backs of PR retaining wall.	ComEd	RELOCATION required 1 day
Weiland Road, 107+00 to 109+22, 53' RT	Electric UG Cable	EX UG cable is located with tie backs of PR retaining wall.	ComEd	RELOCATION required 1 day
Weiland Road, 108+15, 52' LT	Electric UG Cable	EX UG cable crosses temporary light pole foundation.	ComEd	RELOCATION required 1 day
Weiland Road, 113+40, 65' RT	Telephone Pedestal	EX pedestal is in conflict with PR storm sewer.	AT&T	RELOCATION required 3 days
Weiland Road, 115+56, 50' LT	Telephone Pedestal	EX pedestal is in conflict with roadway expansion.	AT&T	RELOCATION required 3 days

Aptakistic Road, 101+18, 34' RT to 111+53, 52' RT	8" Gas Line	EX gas line is located underneath PR curb and gutter, roadway, and 0.6' cut.	North Shore Gas	RELOCATION required 1 day
Aptakistic Road, 103+60, 33' RT	8" Gas Line	EX gas line crosses PR catch basin.	North Shore Gas	RELOCATION required 1 day
Aptakistic Road, 104+60, 34' LT	Telephone Pedestal	EX pedestal is within PR roadway.	AT&T	RELOCATION required 3 days
Aptakistic Road, 104+70, 36' LT	Electric Utility Pole	EX pole is within PR roadway.	ComEd	RELOCATION required 1 day
Aptakistic Road, 105+28, 39' RT	8" Gas Line	EX gas line crosses PR catch basin.	North Shore Gas	RELOCATION required 1 day
Aptakistic Road, 105+37, 32' LT	Telephone UG Cable	EX cable is in conflict with PR manhole.	AT&T	RELOCATION required 1 day
Aptakistic Road, 106+02, 37' RT	Telephone Pedestal	EX pedestal is within PR roadway.	AT&T	RELOCATION required 3 days
Aptakistic Road, 106+27, 39' LT	Electric Utility Pole	EX pole is within PR roadway.	ComEd	RELOCATION required 1 day
Aptakistic Road, 106+28, 38' LT	Telephone UG Cable	EX UG cable is within PR roadway.	AT&T	RELOCATION required 1 day
Aptakistic Road, 106+28, 39' RT	Telephone Pedestal	EX pedestal is within PR roadway.	AT&T	RELOCATION required 3 days

Aptakisic Road, 106+38, 38' LT	Telephone Cabinet	EX cabinet is within PR roadway.	AT&T	RELOCATION required 3 days
Aptakisic Road, 106+47, 54' RT	Telephone UG Cable	EX UG cable crosses PR storm sewer.	AT&T	RELOCATION required 1 day
Aptakisic Road, 106+74, 56' RT	Telephone UG Cable	EX UG cable crosses PR storm sewer.	AT&T	RELOCATION required 1 day
Aptakisic Road, 106+77, 39' LT	Electric Utility Pole	EX pole is located within PR roadway.	ComEd	RELOCATION required 1 day
Aptakisic Road, 107+29, 39' LT	Electric Utility Pole	EX pole is located within PR roadway.	ComEd	RELOCATION required 1 day
Aptakisic Road, 109+08, 38' LT	Electric Utility Pole	EX pole is located within PR roadway.	ComEd	RELOCATION required 1 day
Aptakisic Road, 109+87, 68' LT	Telephone Pedestal	EX pedestal is within PR roadway.	AT&T	RELOCATION Required 3 day
Aptakisic Road, 110+99, 41' LT	Electric Utility Pole	EX pole is located within PR curb and gutter.	ComEd	RELOCATION required 1 day
Aptakisic Road, 111+04, 41' LT	Electric Utility Pole	EX pole is located within PR curb and gutter.	ComEd	RELOCATION required 1 day
Aptakisic Road, 112+15, 41' LT	Utility Pole	EX pole is located within PR curb and gutter.	ComEd	RELOCATION required 1 day

Aptakisic Road, 112+69, 41' LT	Utility Pole	EX pole is located within PR curb and gutter.	ComEd	RELOCATION required 1 day
Aptakisic Road, 112+96, 45' LT	Utility Pole	EX pole is located within PR aggregate improvement.	ComEd	RELOCATION required 1 day
Aptakisic Road, 113+09, 68' RT	UG Fiber Optic Cable	EX UG fiber optic cable crosses PR storm sewer.	Unite Private Networks	RELOCATION required 1 day
Aptakisic Road, 113+41, 40' RT	UG Fiber Optic Cable	EX UG fiber optic cable crosses PR manhole.	Unite Private Networks	RELOCATION required 1 day
Aptakisic Road, 113+41, 52' RT	6" Gas Line	EX gas line crosses PR storm sewer.	North Shore Gas	RELOCATION required 1 day
Aptakisic Road, 113+96, 41' LT	Electric Utility Pole	EX pole is located within PR curb and gutter.	ComEd	RELOCATION required 1 day
Aptakisic Road, 114+28, 49' RT	8" Gas Line	EX gas line crosses PR storm sewer.	North Shore Gas	RELOCATION required 1 day
Aptaksic Road, 114+30, 40' RT	UG Fiber Optic Cable	EX UG fiber optic cable crosses PR storm sewer.	Unite Private Networks	RELOCATION required 1 day
Aptakisic Road, 114+79, 40' LT	Electric Utility Pole	EX pole is located within PR curb and gutter.	ComEd	RELOCATION required 1 day
Aptaksic Road, 115+00, 39' RT	UG Fiber Optic Cable	EX UG fiber optic cable crosses PR catch basin.	Unite Private Networks	RELOCATION required 1 day

Aptakistic Road, 115+18, 39' LT	Electric Utility Pole	EX pole is located within PR curb and gutter.	ComEd	RELOCATION required 1 day
Aptakistic Road, 115+48, 39' LT	Electric Utility Pole	EX pole is located within PR curb and gutter.	ComEd	RELOCATION required 1 day

Pre-Stage: 89 Days Total Installation
Stage 1: 0 Days Total Installation
Stage 2: 0 Days Total Installation

The following contact information is what was used during the preparation of the plans as provided by the Agency/Company responsible for resolution of the conflict.

Agency/Company Responsible to Resolve Conflict	Name of contact	Address	Phone	e-mail address
AT&T	Hector Garcia	1000 Commerce Dr, Oak Brook, IL 60523	(630) 573-5465	hg2929@att.com
Comcast	Robert Schulter	688 Industrial Dr, Elmhurst, IL 60126	(224) 229-5861	Bob_Schulter@ cable.comcast.com
ComEd	Terri Bleck	1500 Franklin Blvd Libertyville, IL 60048	(847) 816-5239	Terri.Bleck@ ComEd.com
Lake County Public Works	Philip Perna	650 W Winchester Rd, Libertyville, IL 60048	(847) 377-7124	PPerna @lakecountyil.gov

Ledcor	Frank Oudin	723 N Oaklawn Ave Elmhurst, IL 60126	(773) 666-0000	Frank.Oudin@ledcor.com
Level 3 Communications	Reece Conrad	1305 E. Algonquin Rd Arlington Heights, IL 60005	(847) 954-8204	Reece.Conrad@level3.com
Nicor Gas	Bruce Koppang	1844 Ferry Rd Naperville, IL 60563	(630) 388-3046	BKoppang@southernco.com
North Shore Gas	Glannie Chan	3001 Grand Ave Waukegan, IL 60085	(847) 263-4687	GChan@peoplesgasdelivery.com
Northwest Water Commission	David Neybert	1525 N. Wolf Rd Des Plaines, IL 60016	(847) 635-0777	DNeybert@northwestwater.org
Turnkey Network Solutions	Erica Filkins	7020 Southbelt Dr SE Caledonia, MI 49316	(616) 988-5308	EFilkins@tkns.net
Unite Private Network	George Forbes	-	(478) 832-0669	George.Forbes@upnllc.com

UTILITIES TO BE WATCHED AND PROTECTED

The areas of concern noted below have been identified by following the suggested staging plan included for the contract. The information provided is not a comprehensive list of all remaining utilities, but those which during coordination were identified as ones which might require the Department's contractor to take into consideration when making the determination of the means and methods that would be required to construct the proposed improvement. In some instances the contractor will be responsible to notify the owner in advance of the work to take place so necessary staffing on the owners part can be secured.

Stage 1

STAGE / LOCATION	TYPE	DESCRIPTION	OWNER	ACTION
Weiland Road, 79+54, 35' RT	UG Fiber Optic Cable	EX UG fiber optic cable crosses PR storm sewer.	Unite Private Networks	To Be PROTECTED
Weiland Road, 79+66, 41' RT	8" Sanitary Sewer	EX sanitary sewer crosses PR storm sewer.	Village of Buffalo Grove	To Be PROTECTED
Weiland Road, 79+76, 35' RT	16" Water Main	EX water main crosses PR storm sewer.	Northwest Water Commission	To Be PROTECTED
Weiland Road, 81+71, 53' RT	8" Sanitary Sewer	EX sanitary sewer crosses PR storm sewer.	Village of Buffalo Grove	To Be PROTECTED
Weiland Road, 81+72, 36' RT	4" Gas Main	EX gas main crosses PR storm sewer.	North Shore Gas	To Be PROTECTED
Weiland Road, 81+91, 40' RT	Electric Utility Pole	EX pole is located within parkway.	ComEd	To Be PROTECTED
Weiland Road, 82+00, 34' RT	30" Gas Main	EX gas main crosses underneath PR curb and gutter.	North Shore Gas	To Be PROTECTED

Weiland Road, 82+18 to 83+06, 42' RT	4" Gas Line	EX gas line is located underneath PR roadway.	North Shore Gas	To Be PROTECTED
Weiland Road, 82+69, 54, RT to 84+30, 59' RT	8" Water Main	EX water main is located underneath the PR sidewalk.	Village of Buffalo Grove	To Be PROTECTED
Weiland Road, 83+30, 51' RT	Electric Utility Pole	EX pole is located near PR sidewalk.	ComEd	To Be PROTECTED
Weiland Road, 83+98, 54' RT	Electric Utility Pole	EX pole is located within PR sidewalk.	ComEd	To Be PROTECTED
Weiland Road, 84+67, 54' RT	Electric Utility Pole	EX pole is within limits of construction.	ComEd	To Be PROTECTED
Weiland Road, 86+41, 57' RT	Electric UG Cable	EX UG cable is located within limits of construction.	ComEd	To Be PROTECTED
Weiland Road, 87+68, 57' RT	Electric Utility Pole	EX pole is located within limits of construction.	ComEd	To Be PROTECTED
Weiland Road, 88+71	8" Water Main	EX water main crosses PR roadway that is being lowered by 2.35'.	Village of Buffalo Grove	To Be PROTECTED
Weiland Road, 89+31, 62' RT	Electric Utility Pole	EX pole is located outside of ROW.	ComEd	To Be PROTECTED

Weiland Road, 89+69, 65' RT	Electric Utility Pole	EX pole is located outside of ROW.	ComEd	To Be PROTECTED
Weiland Road, 92+96, 52' RT	12" Water Main	EX water main crosses PR storm sewer.	Village of Buffalo Grove	To Be PROTECTED
Weiland Road, 92+99, 53' RT	Cable TV UG Cable	EX UG cable crosses PR storm sewer.	Comcast	To Be PROTECTED
Weiland Road, 93+06, 56' RT	UG Fiber Optic Cable	EX UG fiber optic cable crosses PR storm sewer within 1.5'.	Unite Private Networks	To Be PROTECTED
Weiland Road, 93+09, 53' RT	Telephone UG Cable	EX UG cable is in potential conflict with PR manhole.	AT&T	To Be PROTECTED
Weiland Road, 93+14, 34' RT	4" Gas Line	EX gas line crosses PR storm sewer.	North Shore Gas	To Be PROTECTED
Weiland Road, 93+84, 54' RT	Telephone UG Cable	EX UG cable crosses PR storm sewer.	AT&T	To Be PROTECTED
Weiland Road, 93+87, 53' RT	Cable TV UG Cable	EX UG cable crosses PR storm sewer.	Comcast	To Be PROTECTED
Weiland Road, 93+89, 52' RT	UG Fiber Optic Cable	EX UG fiber optic cable crosses PR storm sewer.	Unite Private Networks	To Be PROTECTED

Weiland Road, 94+05, 46' RT	Electric UG Cable	EX UG cable crosses PR storm sewer.	ComEd	To Be PROTECTED
Weiland Road, 94+16, 29' RT	4" Gas Line	EX gas line crosses PR storm sewer.	North Shore Gas	To Be PROTECTED
Weiland Road, 95+75, 25' RT	4" Gas Line	EX gas line crosses PR storm sewer.	North Shore Gas	To Be PROTECTED
Weiland Road, 96+08, 43' RT	Cable TV UG Cable	EX UG cable crosses PR storm sewer.	Comcast	To Be PROTECTED
Weiland Road, 96+12, 43' RT	Electric UG Cable	EX UG cable crosses PR storm sewer.	ComEd	To Be PROTECTED
Weiland Road, 96+25, 43' RT	UG Fiber Optic Cable	EX UG fiber optic cable crosses PR storm sewer.	Unite Private Networks	To Be PROTECTED
Weiland Road, 96+35, 39' RT	Electric Utility Pole	EX pole is located within parkway.	ComEd	To Be PROTECTED
Weiland Road, 96+43, 22' RT	4" Gas Line	EX gas line crosses PR storm sewer.	North Shore Gas	To Be PROTECTED
Weiland Road, 96+43, 41' RT	Electric UG Cable	EX UG cable crosses PR storm sewer.	ComEd	To Be PROTECTED

Weiland Road, 96+68, 39' RT	Electric Utility Pole	EX pole is within parkway.	ComEd	To Be PROTECTED
Weiland Road, 96+98, 39' RT	Electric Utility Pole	EX pole is within parkway.	ComEd	To Be PROTECTED
Weiland Road, 97+35, 43' RT	Cable TV UG Cable	EX UG cable crosses PR storm sewer.	Comcast	To Be PROTECTED
Weiland Road, 97+50, 19' RT	4" Gas Line	EX gas line crosses PR storm sewer.	North Shore Gas	To Be PROTECTED
Weiland Road, 97+50, 38' RT	Cable TV UG Cable	EX UG cable crosses PR storm sewer.	Comcast	To Be PROTECTED
Weiland Road, 99+25, 20' RT	4" Gas Line	EX gas line crosses PR storm sewer.	North Shore Gas	To Be PROTECTED
Weiland Road, 100+61, 40' RT	Electric Utility Pole	EX pole is located within parkway.	ComEd	To Be PROTECTED
Weiland Road, 102+29, 57' RT	Electric Utility Pole	PR temporary aerial light cables is close to EX pole.	ComEd	To Be PROTECTED
Weiland Road, 103+80, 83' RT	Electric Utility Pole	EX pole is located within limits of construction.	ComEd	To Be PROTECTED

Weiland Road, 105+82, 43' RT	Electric UG Cable	EX UG cable crosses PR storm sewer.	ComEd	To Be PROTECTED
Weiland Road, 105+90, 38' RT	Electric UG Cable	EX UG cable crosses PR storm sewer.	ComEd	To Be PROTECTED
Weiland Road, 107+25, 40' RT to 111+00, 64' RT	Electric UG Cable	EX UG cable runs underneath PR curb and gutter.	ComEd	To Be PROTECTED
Weiland Road, 110+00, 57' RT	Electric UG Cable	EX UG cable cross PR storm sewer.	ComEd	To Be PROTECTED
Weiland Road, 110+00, 61' RT	Electric UG Cable	EX UG cable cross PR storm sewer.	ComEd	To Be PROTECTED
Weiland Road, 110+24	8" Sanitary Sewer	EX sanitary sewer crosses roadway.	Village of Buffalo Grove	To Be PROTECTED
Weiland Road, 110+86 to 115+60, 47' RT	16" Water Main	EX water main is located underneath PR curb and gutter and roadway.	Village of Buffalo Grove	To Be PROTECTED
Weiland Road, 110+93, 65' RT	Electric UG Cable	EX UG cable cross PR storm sewer.	ComEd	To Be PROTECTED
Weiland Road, 111+00, 65' RT	Electric UG Cable	EX UG cable cross PR storm sewer.	ComEd	To Be PROTECTED

Weiland Road, 115+03	16" Water Main	EX water main crosses PR roadway.	Village of Buffalo Grove	To Be PROTECTED
Aptakistic Road, 101+24, 39' LT	Electric Utility Pole	EX pole is located within limits of construction.	ComEd	To Be PROTECTED
Aptakistic Road, 101+36, 35' RT	8" Gas Line	EX gas line crosses PR storm sewer.	North Shore Gas	To Be PROTECTED
Aptakistic Road, 106+21, 23' RT	8" Gas Line	EX gas line crosses PR storm sewer.	North Shore Gas	To Be PROTECTED
Aptakistic Road, 106+98, 52' RT	8" Gas Line	EX gas line crosses PR catch basin.	North Shore Gas	To Be PROTECTED
Aptakistic Road, 109+99	Electric UG Cable	EX UG cable crosses PR roadway.	ComEd	To Be PROTECTED
Aptakistic Road, 111+53, 52' RT to 114+53, 48' RT	8" Gas Line	EX gas line is located underneath PR sidewalk.	North Shore Gas	To Be PROTECTED
Aptakistic Road, 113+06, 52' RT	6" Gas Line	EX gas line crosses PR storm sewer.	North Shore Gas	To Be PROTECTED
Aptakistic Road, 114+29, 46' RT	Oil Pipeline	EX pipeline crosses PR storm sewer.	West Shore Pipeline	To Be PROTECTED

Aptakistic Road, 115+27, 62' RT	Electric Utility Pole	EX pole is outside of ROW.	ComEd	To Be PROTECTED
Aptakistic Road, 115+83, 45' RT to 119+96, 32' RT	6" Gas Line & Vault	EX gas line and vault are located underneath PR curb and gutter and roadway.	North Shore Gas	To Be PROTECTED
Aptakistic Road, 117+47, 39' LT	Electric Utility Pole	EX pole is within limits of construction.	ComEd	To Be PROTECTED
Aptakistic Road, 117+49, 40' LT	Electric Utility Pole	EX pole is within limits of construction.	ComEd	To Be PROTECTED
Aptakistic Road, 119+33, 37' RT	Electric Utility Pole	EX pole is within limits of construction.	ComEd	To Be PROTECTED
Aptakistic Road, 119+32, 40' LT	Electric Utility Pole	EX pole is within limits of construction.	ComEd	To Be PROTECTED
Aptakistic Road, 120+98, 37' LT	Electric Utility Pole	EX pole is within limits of construction.	ComEd	To Be PROTECTED

Stage 2

STAGE / LOCATION	TYPE	DESCRIPTION	OWNER	ACTION
Weiland Road, 75+64 to 76+14, 45' LT	16" Water Main	EX water main is located underneath PR sidewalk.	Northwest Water Commission	To Be PROTECTED

Weiland Road, 76+47, 53' LT	Electric Utility Pole	EX pole is within limits of construction.	ComEd	To Be PROTECTED
Weiland Road, 77+22, 53' LT	Electric Utility Pole	EX pole is within limits of construction.	ComEd	To Be PROTECTED
Weiland Road, 78+44, 53' LT	Electric Utility Pole	EX pole is located near PR sidewalk.	ComEd	To Be PROTECTED
Weiland Road, 78+81, 46' LT	16" Water Main	EX water main crosses PR driveway that is being lowered by 0.6'.	Village of Buffalo Grove	To Be PROTECTED
Weiland Road, 79+04	8" Sanitary Sewer	EX sanitary sewer crosses PR roadway.	Village of Buffalo Grove	To Be PROTECTED
Weiland Road, 80+05	16" Water Main	EX water main crosses PR roadway that is being lowered by 0.65'.	Northwest Water Commission	To Be PROTECTED
Weiland Road, 80+05 to 82+91, 45' LT	16" Water Main	EX water main is located underneath the PR multi-use path.	Village of Buffalo Grove	To Be PROTECTED
Weiland Road, 82+64, 39' LT	Electric Utility Pole	EX pole is located within parkway.	ComEd	To Be PROTECTED
Weiland Road, 82+68	16" Water Main	EX water main is located underneath the PR roadway.	Village of Buffalo Grove	To Be PROTECTED

Weiland Road, 82+85, 42' LT	Telephone Pedestal	EX pedestal is located within 1' fill.	AT&T	To Be PROTECTED
Weiland Road, 86+97, 34' LT	Telephone UG Cable	EX UG cable is in potential conflict with PR inlet.	AT&T	To Be PROTECTED
Weiland Road, 92+93	12" Water Main	EX water main crosses PR roadway that is being lowered by 1.25'.	Village of Buffalo Grove	To Be PROTECTED
Weiland Road, 100+90, 40' LT	16" Water Main	EX water main crosses PR storm sewer.	Village of Buffalo Grove	To Be PROTECTED
Weiland Road, 100+90, 40' LT	Electric UG Cable	EX UG cable crosses PR storm sewer.	ComEd	To Be PROTECTED
Weiland Road, 101+03 to 102+16, 37' LT	16" Water Main	EX water main crosses PR side street.	Village of Buffalo Grove	To Be PROTECTED
Weiland Road, 101+18	8" Sanitary Sewer	EX sanitary sewer crosses PR roadway.	Village of Buffalo Grove	To Be PROTECTED
Weiland Road, 101+25, 37' LT	8" Sanitary Sewer	EX sanitary sewer crosses PR storm sewer.	Village of Buffalo Grove	To Be PROTECTED
Weiland Road, 101+27, 37' LT	Electric UG Cable	EX UG cable crosses PR storm sewer.	ComEd	To Be PROTECTED

Weiland Road, 101+33, 37' LT	Electric UG Cable	EX UG cable crosses PR storm sewer.	ComEd	To Be PROTECTED
Weiland Road, 102+16 to 110+86, 48' LT	16" Water Main	EX water main is located underneath the PR multi-use path.	Village of Buffalo Grove	To Be PROTECTED
Aptakistic Road, 116+52, 39' LT	Electric Utility Pole	EX pole is located near PR curb and gutter.	ComEd	To Be PROTECTED

The following contact information is what was used during the preparation of the plans as provided by the owner of the facility.

Agency/Company Responsible to Resolve Conflict	Name of contact	Address	Phone	e-mail address
AT&T	Hector Garcia	1000 Commerce Dr, Oak Brook, IL 60523	(630) 573-5465	hg2929@att.com
Comcast	Robert Schulter	688 Industrial Dr, Elmhurst, IL 60126	(224) 229-5861	Bob_Schulter@ cable.comcast.com
ComEd	Terri Bleck	1500 Franklin Blvd Libertyville, IL 60048	(847) 816-5239	Terri.Bleck@ ComEd.com
Lake County Public Works	Philip Perna	650 W Winchester Rd, Libertyville, IL 60048	(847) 377-7124	PPerna @lakecountyil.gov

Ledcor	Frank Oudin	723 N Oaklawn Ave Elmhurst, IL 60126	(773) 666-0000	Frank.Oudin @ledcor.com
Level 3 Communications	Reece Conrad	1305 E. Algonquin Rd Arlington Heights, IL 60005	(847) 954-8204	Reece.Conrad @level3.com
Nicor Gas	Bruce Koppang	1844 Ferry Rd Naperville, IL 60563	(630) 388-3046	BKoppang @southernco.com
North Shore Gas	Glannie Chan	3001 Grand Ave Waukegan, IL 60085	(847) 263-4687	GChan @peoplesgas delivery.com
Northwest Water Commission	David Neybert	1525 N. Wolf Rd Des Plaines, IL 60016	(847) 635-0777	DNeybert@northwest water.org
Turnkey Network Solutions	Erica Filkins	7020 Southbelt Dr SE Caledonia, MI 49316	(616) 988-5308	EFilkins@tkns.net
Unite Private Network	George Forbes	-	(478) 832-0669	George.Forbes @upnllc.com

The above represents the best information available to the Department and is included for the convenience of the bidder. The days required for conflict resolution should be taken into account in the bid as this information has also been factored into the timeline identified for the project when setting the completion date. The applicable portions of the Standard Specifications for Road and Bridge Construction shall apply.

Estimated duration of time provided in the action column for the first conflicts identified will begin on the date of the executed contract regardless of the status of the utility relocations. The

responsible agencies will be working toward resolving subsequent conflicts in conjunction with contractor activities in the number of days noted.

The estimated relocation dates must be part of the progress schedule submitted by the contractor. A utility kickoff meeting will be scheduled between the Department, the Department's contractor and the utility companies. The Department's contractor is responsible for contacting J.U.L.I.E. prior to any and all excavation work.

TEMPORARY INFORMATION SIGNING (D-1)

Effective: November 13, 1996

Revised: January 2, 2007

Description: This work shall consist of furnishing, installing, maintaining, relocating for various states of construction and eventually removing temporary informational signs. Included in this item may be ground mount signs, skid mount signs, truss mount signs, bridge mount signs, and overlay sign panels which cover portions of existing signs.

Materials: Materials shall be according to the following Articles of Section 1000 - Materials:

	<u>Item</u>	<u>Article/Section</u>
a.)	Sign Base (Notes 1 & 2)	1090
b.)	Sign Face (Note 3)	1091
c.)	Sign Legends	1092
d.)	Sign Supports	1093
e.)	Overlay Panels (Note 4)	1090.02

Note 1. The Contractor may use 5/8 inch (16 mm) instead of 3/4 inch (19 mm) thick plywood.

Note 2. Type A sheeting can be used on the plywood base.

Note 3. All sign faces shall be Type A except all orange signs shall meet the requirements of Article 1106.01.

Note 4. The overlay panels shall be 0.08 inch (2 mm) thick.

GENERAL CONSTRUCTION REQUIRMENTS

Installation: The sign sizes and legend sizes shall be verified by the Contractor prior to fabrication. Signs which are placed along the roadway and/or within the construction zone shall be installed according to the requirements of Article 701.14 and Article 720.04. The signs shall be 7 ft (2.1 m) above the near edge of the pavement and shall be a minimum of 2 ft (600 mm) beyond the edge of the paved shoulder. A minimum of two (2) posts shall be used.

The attachment of temporary signs to existing sign structures or sign panels shall be approved by the Engineer. Any damage to the existing signs due to the Contractor's operations shall be repaired or signs replaced, as determined by the Engineer, at the Contractor's expense.

Signs which are placed on overhead bridge structures shall be fastened to the handrail with stainless steel bands. These signs shall rest on the concrete parapet where possible. The Contractor shall furnish mounting details for approval by the Engineer.

Method of Measurement: This work shall be measured for payment in square feet (square meters) edge to edge (horizontally and vertically).

All hardware, posts or skids, supports, bases for ground mounted signs, connections, which are required for mounting these signs will be included as part of this pay item.

Basis of Payment: This work shall be paid for at the contract unit price per square foot (square meter) for TEMPORARY INFORMATION SIGNING.

TEMPORARY PAVEMENT (D-1)

Effective: March 1, 2003

Revised: April 10, 2008

Description. This work shall consist of constructing a temporary pavement at the locations shown on the plans or as directed by the engineer.

The contractor shall use either Portland cement concrete according to Sections 353 and 354 of the Standard Specifications or HMA according to Sections 355, 356, 406 of the Standard Specifications, and other applicable HMA special provisions as contained herein. The HMA mixtures to be used shall be specified in the plans. The thickness of the Temporary Pavement shall be as described in the plans. The contractor shall have the option of constructing either material type if both Portland cement concrete and HMA are shown in the plans.

Articles 355.08 and 406.11 of the Standard Specifications shall not apply.

The removal of the Temporary Pavement, if required, shall conform to Section 440 of the Standard Specification.

Method of Measurement. Temporary pavement will be measured in place and the area computed in square yards (square meters).

Basis of Payment. This work will be paid for at the contract unit price per square yard (square meter) for TEMPORARY PAVEMENT and TEMPORARY PAVEMENT (INTERSTATE).

Removal of temporary pavement will be paid for at the contract unit price per square yard (square meter) for PAVEMENT REMOVAL.

WINTERIZED TEMPORARY ACCESS (D-1)

Effective: January 1, 2012

Revised: March 5, 2012

Description. This work shall consist of constructing, maintaining and removing winterized temporary access for private and commercial entrances and side roads designed for use throughout the winter months.

Materials. Materials shall be according to the following.

<u>ITEM</u>	<u>ARTICLE/SECTION</u>
Hot-Mix Asphalt	1030

Construction Requirements

For projects lasting longer than one construction season, the contractor shall construct and maintain temporary access composed of an HMA surface course over an existing aggregate temporary access. The contractor shall install the winterized temporary access prior to winter shut down at the direction of the engineer. The top 2” of the existing aggregate temporary access should be removed and replaced with 2” of Hot-Mix Asphalt. Compensation will be given for the winterized temporary access at the time of the installation of the Hot-Mix Asphalt surface course.

HMA Surface Course. The Hot-Mix Asphalt surface course shall be 2 in. thick when compacted. HMA Surface Course, Mix “D”, N50 shall be used except as modified by the plans or as directed by the Engineer. This work shall be constructed in accordance with the applicable portions of Section 406 of the Standard Specifications and as directed by the Engineer. The material shall conform to the applicable portions of Section 1030 of the Standard Specifications.

The winterized temporary access shall be constructed to the dimensions and grades of the existing aggregate temporary access.

Maintaining the winterized temporary access shall include repairing the HMA surface course after any operation that may disturb or remove the winterized temporary access to the satisfaction of the Engineer.

When use of the winterized temporary access is discontinued, the winterized temporary access shall be removed according to Article 440.03 of the Standard Specifications. The material shall be disposed of according to Article 202.03 of the Standard Specifications or may be utilized in the permanent construction with the approval of the Engineer.

Method of Measurement. Winterized temporary access for private and commercial entrances and roads will be measured for payment at the contract unit price per square yard for every private entrance, commercial entrance or road constructed for the purpose of winterized temporary access.

Basis of Payment. Winterized temporary access for private and commercial entrances and roads will be paid for at the contract unit price per square yard for TEMPORARY ACCESS (WINTERIZE) as specified in the plans.

Partial payment of the square yard amount bid for each winterized temporary access will be paid according to the following schedule:

(a) Upon construction of the winterized temporary access, sixty percent of the contract unit price per square yard will be paid.

(b) Subject to the approval of the Engineer for the adequate maintenance and removal of the winterized temporary access, the remaining forty percent of the pay item will be paid upon the permanent removal of the temporary access.

TRAFFIC CONTROL PLAN (L.C.-T- SECTION 700)

Effective 09/26/2018

Traffic Control shall be performed according to the applicable sections of the “Standard Specifications”, the “Supplemental Specifications”, the "Illinois Manual on Uniform Traffic Control Devices for Streets and Highways”, the “Quality Standard for Work Zone Traffic Control Devices”, any special details and Highway Standards as shown on the plans and the special provisions contained herein.

Special attention is called to Articles 105.03(b), 105.05, and 107.09, and to Sections 701, 704, and 782 of the “Standard Specifications”, and to the following Highway Standards, Details, Recurring Special Provisions and Special Provisions contained herein, relating to traffic control.

The Contractor shall contact the Engineer at least 72 hours in advance of beginning work.

STANDARDS

701001	Off-Rd Operations, 2L, 2W, More than 15' (4.5 m) Away
701006	Off-Rd Operations, 2L, 2W, 15' (4.5 m) to 24" (600 mm) from Pavement Edge
701101	Off-Rd Operations Multilane, 15' (4.5 m) to 24" (600 mm) from Pavement Edge
701301	Lane Closure, 2L, 2W, Short Time Operations
701311	Lane Closure, 2L, 2W, Moving Operations - Day Only
701326	Lane Closure, 2L, 2W, Pavement Widening, For Speeds \geq 45 mph
701426	Lane Closure, Multilane, Intermittent or Moving Operation, for Speeds \geq 45 mph
701427	Lane Closure, Multilane, Intermittent or Moving Operation, for Speeds Less than or Equal to 40 mph
701501	Urban Lane Closure, 2L, 2W, Undivided
701502	Urban Lane Closure, 2L, 2W, with Bidirectional Left Turn Lane
701601	Urban Lane Closure, Multilane, 1W or 2W with Nontraversable Median
701606	Urban Lane Closure, Multilane, 2W with Mountable Median
701611	Urban Half Road Closure, Multilane, 2W with Mountable Median
701801	Sidewalk, Corner or Crosswalk Closure
701901	Traffic Control Devices

DETAILS

LC 7000	Two Lane, Two Way, Off-Road Operations Day Operations Only
LC 7003	Urban Lane Closure Multilane Intersection
LC 7004	Traffic Control and Protection for Sideroads Intersections and Driveways
LC 7200	Direction Indicator Barricades
LC 7201	Temporary Construction Information Signs
LC 7203	Work Zone Speed Limit Signing Diagram
LC 7800	Typical Pavement Markings for County Highways
LC 7802	Short Term Pavement Markings

LC 7805 Recessed Reflective Pavement Marker
TC-22 Arterial Road Information Sign

RECURRING SPECIAL PROVISIONS

LRS3 Special Provision for Work Zone Traffic Control Surveillance

SPECIAL PROVISIONS

BDE #80298 Temporary Pavement Marking
BDE #80349 Pavement Marking Blackout Tape
BDE #80371 Pavement Marking Removal
BDE #80392 Lights on Barricades
BDE #80409 Traffic Control Devices - Cones
Maintenance of Roadways
Public Convenience and Safety
Temporary Information Signing
Traffic Control and Protection (Special)

DETOURS

Detours and road closures on county maintained roads within Lake County, Illinois shall be according to the applicable Articles and Sections of the “Standard Specifications”, the “Supplemental Specifications”, the “Illinois Manual on Uniform Traffic Control Devices for Streets and Highways”, the Lake County Division of Transportation’s Detour Procedures and Guidelines, any special details and Highway Standards as shown on the Detour Plan and the Special Provisions contained herein. The LCDOT Detour Procedures and Guidelines are available from the LCDOT, Traffic Engineering Section upon request.

TRAFFIC CONTROL AND PROTECTION (SPECIAL) (L.C.-T- SECTION 700)

Effective 09/26/2018

The Traffic Control and Protection (Special) shall meet the requirements of Division 700. Work Zone Traffic Control and Protection, Signing, and Pavement Marking of the “Standard Specifications” except as follows:

Article 701.01 Description shall be replaced with the following:

701.01 Description. This item of work shall consist of furnishing, installing, maintaining, replacing, relocating and removing all traffic control devices used for the purpose of regulating, warning or directing traffic during the construction or maintenance of this improvement.

Article 701.02 Materials shall be modified by adding the following paragraph:

Traffic control devices include signs and their supports, signals, pavement markings, barricades and their approved weights, channeling devices, warning lights, arrow boards, flaggers, or any other device used for the purpose of regulating, detouring, warning or guiding traffic through or around the construction zone.

Article 701.04 General shall be modified by adding the following as the first paragraph:

Traffic Control and Protection (Special) shall be provided as shown on the plans and applicable Highway Standards; as required in these special provisions and the applicable sections of the “Standard Specifications”; and/or as directed by the Engineer.

Article 701.04 General shall be modified by adding the following to the fourth paragraph:

The Contractor shall dispatch men, materials, and equipment to correct any such deficiencies. The Contractor shall respond to any call from LCDOT concerning any request for improving or correcting traffic control devices and begin making the requested repairs within two hours from the time of notification.

Article 701.10 Surveillance shall be replaced with the following:

The Contractor is required to conduct routine inspections of the work site at a frequency that will allow for the timely replacement of any traffic control device that has become displaced, worn or damaged to the extent that it no longer conforms to the shape, dimensions, color and operational requirements of the MUTCD, the Traffic Control Standards, the IDOT Quality Standard For Work Zone Traffic Control Devices, or will no longer present a neat appearance to motorists. A sufficient quantity of replacement devices, based on vulnerability to damage, shall be readily available to meet this requirement.

The Contractor shall ensure that all the traffic control devices he/she installs are operational, functional and effective 24 hours a day, seven days a week, including holidays.

Article 701.13 Flaggers (a) shall be modified by revising the second paragraph of subparagraph (a) by adding the following:

The Engineer will determine when a side road or entrance shall be closed to traffic. The flagger shall be positioned as shown on the plans or as directed by the Engineer.

Article 701.14 Signs (a) Road Construction Ahead Signs shall be modified by changing the following in the paragraph:

“ROAD WORK AHEAD” signs shall be required in lieu of “ROAD CONSTRUCTION AHEAD” SIGNS

Article 701.14 Signs (b) Work Zone Speed Limit Signs shall be revised to read:

- (b) Work Zone Speed Limit Signs. The Lake County Division of Transportation will specify whether a project meets the criteria for a Work Zone Speed Limit. When specified, the work zone speed limit signs shall be installed as shown on the LCDOT Work Zone Speed Limit Signing Diagram, LC7203, at a maximum of 20 feet lateral distance of the locations shown on the plans. Failure to install and maintain the required amount of signs at the proper sign spacing shall result in an immediate traffic control deficiency.

All permanent “SPEED LIMIT” signs located within the work zone shall be removed or covered. If the speed limit sign is to be covered, it shall be done in a manner that no part of the legend shall be visible in any lighting condition. This work shall be completed by the Contractor after the method of covering the speed limit signs has been approved by the Engineer.

The work zone speed limit signs and the end work zone speed limit signs in advance of and at the end of the lane closure(s) shall be used for the duration of the closure(s).

The work zone speed limit signs will be removed when roadway conditions return to normal or when the construction project is suspended for more than 30 days.

Article 701.14 Signs shall be modified by adding the following section (c),

- (c) Temporary Construction Information Signs. When indicated in the traffic control plan or as directed by the Engineer the Contractor shall furnish, install, maintain, relocate, and remove for various stages of construction Temporary Construction Information Signs.

Temporary Construction Information Signs may include:

Driveway	White Legend on Green Background
Caution – New Lanes Open	Black Legend on Orange Background

The signs, as shown on Lake County Detail LC7201, shall be installed according to the traffic control plan and/or as directed by the Engineer.

Article 701.15 Traffic Control Devices (b) Type I, II and III Barricades shall be deleted and replaced with the following:

Type II barricades shall be used at all locations that call for Type I, or Type II barricades.

Type II barricades are used to delineate unattended obstacles, patches, excavations, drop-offs, and other hazards; and as check barricades

Barricades that must be placed in excavated areas shall have leg extensions installed so that the top of the barricade is in compliance with the height requirements of IDOT Standard 701901.

Check barricades shall be placed in work areas perpendicular to traffic every 1,000 feet, at one per lane and one per shoulder, to prevent motorists from using work areas as a traveled way. Two additional check barricades shall be placed in advance of each patch excavation or any other hazard in the work area. The first will be placed at the edge of the open traffic lane and the second centered on the closed lane. Check barricades shall be Type II and equipped with flashing amber light.

Type III barricades are used to close traffic lanes and to close roads.

Article 701.15 Traffic Control Devices (e) Direction Indicator Barricades shall be modified by adding the following paragraph.

The direction indicator barricades shall meet the requirements for Type II barricades as stated in this special provision. The top panel, which faces traffic, shall be as shown in IDOT Highway Standard 701901. The top panel, facing away from traffic shall have a 12 inch x 24 inch orange and white diagonal panel. The bottom panels shall be eight inches x 24 inches with orange and white diagonal sheeting, as shown in LCDOT's Special Detail LC7200.

Article 701.15 Traffic Control Devices (f) Drums shall be modified by adding the following paragraph:

Any drop off greater than three inches, but less than six inches, located within eight feet of the pavement edge shall be protected by drums equipped with mono-directional steady burn lights. The drums shall be placed at a spacing of 100 feet center to center. For any drop off within eight feet of the pavement edge that exceeds six inches, but does not exceed the thresholds contained in IDOT's Safety Engineering Policy Memorandum 4-15 for the use of temporary concrete barrier, drums equipped with mono-directional steady burn lights shall be placed at a spacing of 50 feet center to center.

Article 701.15 Traffic Control Devices (j) Portable Changeable Message Signs shall be modified by adding the following paragraphs:

The PCMS shall be compatible and fully functional with the LCDOT's Transportation Management Center PASSAGE PCMS Control Software. A list of approved PCMS's manufacturers and traffic control vendors is available upon request from the LCDOT. The PCMS shall be tested and approved by the LCDOT and can be sufficiently controlled by the LCDOT NTCIP compliant software. If the PCMS has not been tested or approved by either the Illinois State Toll Highway Authority or the LCDOT then the PCMS will need to be tested and certified by the Delcan Corporation at the Contractor's expense.

Lake County Division of Transportation (PASSAGE)

Software Developer:
Parsons
650 East Algonquin Road, Suite 400
Schaumburg, IL 60173

In case of a Traffic Incident Management (TIM) event or other County/State declared Emergency Management event, the use of the PCMS may be pre-empted from the Contractor's use by the Lake County Transportation Management Center for the duration of the incident. If the PCMS must be moved from the limits of the work site to an offsite location to better facilitate the use of the PCMS during the incident, the Contractor will be compensated for the labor and equipment to move the PCMS to the designated location and back, according to Article 109.04 (b) of the "Standard Specifications". In order to facilitate the movement of the PCMS in a timely manner, the LCDOT may use County Forces to move the PCMS to the designated location and/or back, at no additional cost to the Contractor.

When the sign(s) are displaying messages, they shall be considered a traffic control device. At all other times when no message is displayed, they shall be considered equipment.

Article 701.17 Specific Construction Operations (c) Surface Courses and Pavement (1) Prime Coat shall be replaced by the following:

- (1) Prime Coat. "FRESH OIL" signs (W21-2) shall be used when the prime coat is applied to pavement that is open to traffic. The signs shall remain in place until tracking of the prime ceases. These signs shall be erected a minimum of 500 feet preceding the start of the prime and on all side roads within the posted area. The signs on the side roads shall be posted a minimum of 200 feet from the mainline pavement. These signs are excluded from the time requirements of Article 701.04 of the "Standard Specifications" as modified by this special provision (above). Non-compliance with the provisions of this section, by the Contractor, shall result in an immediate traffic control deficiency deduction. All signs shall have an amber flashing light attached.

Article 701.17 Specific Procedures (c) Surface Courses and Pavement (2) Cold Milling shall be replaced by the following:

- (2) Cold Milling. "ROUGH GROOVED SURFACE" signs (W8-I107) shall be used when the road has been cold milled and is open to traffic. The signs shall remain in place until the milled surface condition no longer exists. These signs shall be erected a minimum of 500 feet preceding the start of the milled pavement and on all side roads within the posted area. The signs on the side roads shall be posted a minimum of 200 feet from the mainline pavement. Non-compliance with the provisions of this section, by the Contractor, shall result in an immediate traffic control deficiency deduction. All signs shall have an amber flashing light attached.

Article 701.17 Specific Procedures (c) Surface Course and Pavement shall be modified by adding the following paragraph:

- (6) Area Reflective Crack Control Treatment Fabric. "SLIPPERY WHEN WET" signs (W8-5) shall be used when crack control fabric is applied to pavement that is open to traffic. These signs shall remain in place until the binder course is laid. The signs shall be erected a minimum of 500 feet preceding the start of the crack control treatment and on all side roads within the posted area. The signs on the side roads shall be posted a minimum of 200 feet from the mainline pavement. These signs are excluded from the time requirements of Article 701.04 of the "Standard Specifications" as modified by this special provision (above). Non-compliance with the provisions of this section, by the Contractor, shall result in an immediate traffic control deficiency deduction. All signs shall have an amber flashing light attached.

Article 701.18 Highway Standards Application (b) Standard 701316 and 701321 (2) g.
Detector Loops, shall be replaced with the following:

- g. Detection. Microwave Vehicle Sensors shall be installed as directed by the Engineer. The LCDOT shall approve the proposed microwave vehicle sensor before the Contractor may furnish or install it. The Contractor shall install, wire and adjust the alignment of the sensor according to the manufacturer's recommendations and requirements. The Engineer shall approve the installation. An alternate method of detection may be used if it has been demonstrated and approved by the Department.

The microwave vehicle sensor shall meet the following requirements:

- Detection Range: Adjustable to 60 feet
- Detection Angle: Adjustable, horizontal and vertical
- Detection Pattern: 16 degree beam width minimum [at 50 feet the pattern shall be approximately 15.5 feet wide]
- Mounting: Heavy-duty bracket, predrilled and slotted for pole mounting
- LED Indicator Light: For detection verification

Article 701.18 Highway Standards Application (j) Urban Traffic Control, Standards 701501, 701502, 701601, 701602, 701606, 701701, and 701801 (1) General, shall be modified by adding the following paragraphs:

Whenever a lane is closed to traffic using IDOT standard 701601, 701606, or 701701, the pavement width transition sign (W4-2R or W4-2L) shall be used in lieu of the "WORKERS" sign (W21-1 or W21-1a)

Whenever any vehicle, equipment, workers or their activities infringe on the shoulder or within 15 feet of the traveled way, and the traveled way remains unobstructed, then the applicable Traffic Control Standard shall be 701006, 701011, 701101, or 701701. The "SHOULDER WORK AHEAD" sign (W21-5(0)-48) shall be used in lieu of the "WORKERS" sign (W21-1 or W-21-1a).

Article 701.18 Highway Standards Application shall be modified by adding the following section (l):

- (l) IDOT standard 701331. When IDOT standard 701331 is specified on two-lane, two-way roadways, a "LANE SHIFT AHEAD" sign shall be added 500 feet in advance of W1-3 or W1-4 sign. The Road Work sign (W20-1) shall be extended to a total of 1500' from the start of the lane shift.

Article 701.19 Method of Measurement shall be replaced completely with the following:

701.19 Method of Measurement.

These items of work will be measured on a lump sum basis for furnishing installing, maintaining, replacing, relocating and removing the traffic control devices required in the plans and these special provisions.

Article 701.20 Basis of Payment shall be replaced completely with the following:

701.20 Basis of Payment

This work will be paid for at the contract unit price per lump sum for TRAFFIC CONTROL AND PROTECTION (SPECIAL). The payment will be in full for all labor, materials, transportation, and incidentals necessary to furnish, install, maintain, replace, relocate and remove all traffic control devices indicated in the plans and specifications, except for the following items, which will be paid for separately.

- 1) Temporary Bridge Traffic Signals
- 2) Temporary Rumble Strips [where each is defined as 25 feet]
- 3) Temporary Raised Pavement Markers
- 4) Sand module impact attenuators
- 5) Portable Changeable Message Signs
- 6) Temporary Concrete Barrier
- 7) Temporary Pavement Marking-Letters and Symbols
- 8) Temporary Pavement Marking-Line at width specified

The salvage value of the materials removed shall be reflected in the bid price for this item.

Any delays or inconveniences incurred by the Contractor while complying with these requirements shall be considered as part of TRAFFIC CONTROL AND PROTECTION (SPECIAL) and no additional compensation will be allowed.

Any traffic control devices required by the Engineer to implement the Traffic Control Plan as shown in the plans and specifications of the contract shall be considered included in the pay item TRAFFIC CONTROL AND PROTECTION (SPECIAL).

If the Engineer requires additional work involving a substantial change of location and/or work which differs in design and/or work requiring a change in the type of construction, as stated in Article 104.02(d) of the "Standard Specifications", the standards and/or the designs, other than those required in the plans, will be made available to the Contractor at least one week in advance of the change in traffic control. Payment for any additional traffic control required for the reasons listed above will be in accordance with Article 109.04 of the "Standard Specifications".

Revisions in the phasing of construction or maintenance operations, requested by the Contractor, may require traffic control to be installed according to standards and/or designs other than those included in the plans. The Contractor shall submit revisions or modifications to the traffic control plan shown in the contract to the Engineer for approval. No additional payment will be made for a Contractor requested modification.

In the event the sum total of all work items for which traffic control and protection is required is increased or decreased by more than ten percent, the contract bid price for TRAFFIC CONTROL AND PROTECTION (SPECIAL) will be adjusted as follows:

$$\text{Adjusted Contract Price} = 0.25P + 0.75P [1 \pm (X - 0.1)]$$

P = the contract price for TRAFFIC CONTROL AND PROTECTION (SPECIAL)

$$X = \frac{\text{Difference between original and final value of work for which traffic control and protection is required.}}{\text{Original value of work for which traffic control and protection is required.}}$$

The value of the work items used in calculating the increase and decrease will include only items that have been added to or deducted from the contract under Article 104.02 of the "Standard Specifications" and only items that require the use of TRAFFIC CONTROL AND PROTECTION (SPECIAL).

In the event LCDOT cancels or alters any portion of the contract that result in the elimination or incompleteness of any portion of the work, payment for partially completed work will be made according to Article 104.02 of the "Standard Specifications".

LAKE COUNTY DOT TRAFFIC SIGNAL GENERAL REQUIREMENTS

Effective: October 15, 2016
 Revised: March 1, 2019
 LC800.01

All work and equipment performed and installed under this Contract shall be governed by and shall comply with:

<u>SPECIFICATION</u>	<u>ADOPTED/DATED</u>
The State of Illinois "Standard Specifications for Road and Bridge Construction" referred to as "Standard Specifications"	April 1, 2016
The State of Illinois "Manual on Uniform Traffic Control Devices for Streets and Highways," referred to as "MUTCD"	June 2014
The National Electrical Code referred to as "NEC"	2011 Edition
The National Electrical Manufacturers Association (All publications for traffic control items) referred to as "NEMA"	All applicable current documents published prior to Contract Letting Date
The International Municipal Signal Association ("Official Wire & Cable Specifications Manual,") referred to as "IMSA"	All applicable current documents published prior to Contract Letting Date
The Institute of Transportation Engineers ATC Version 6 Standard	January 12, 2018
AASHTO "Standard Specifications" LRFD Specifications for Structural Supports for Highway Signs, Luminaires, and Traffic Signals	2015 Edition & 2017 Interim Revisions
Supplemental Specifications and Recurring Special Provisions	January 1, 2018

The project Special Provisions supplement the above specifications, manuals, and codes. In case of conflict with any part or parts of said documents, the project Special Provisions shall take precedence and shall govern.

The following terms and acronyms are used:

IDOT	Illinois Department of Transportation
District 1	IDOT District 1
LCDOT	The Lake County Division of Transportation
Traffic Engineer	The LCDOT Traffic Engineer or designee
PASSAGE	Lake County's ITS System
PASSAGE Consultant	Parsons Transportation Group

The intent of these Special Provisions is to prescribe the materials and construction methods commonly used in traffic signal installations. All material furnished shall be new. The locations and the details of all installations shall be indicated on the plans or as directed by the Engineer.

All traffic signal work related to the traffic signal cabinet shall be performed with at least one electrician holding a current IMSA Traffic Signal Technician Level 2 certification present on site and actively overseeing and directing the work, unless approved in advance by the Traffic Engineer.

The work performed under this Contract shall consist of furnishing and installing all traffic signal work as shown on the plans and as specified herein in a manner acceptable and approved by the Resident Engineer.

Definitions of Terms.

Add the following to Section 101 of the Standard Specifications:

101.56 Vendor. Company that sells a particular type of product directly to the Contractor or the Equipment Supplier.

101.57 Equipment Supplier. Company that supplies, represents, and provides technical support for District 1 approved traffic signal controllers and other related equipment. The Equipment Supplier shall be located within District 1 and shall:

- a. Be full service with on-site facilities to assemble, test and trouble-shoot traffic signal controllers and cabinet assemblies.
- b. Maintain an inventory of District 1 approved controllers and cabinets.
- c. Be staffed with permanent sales and technical personnel able to provide traffic signal controller and cabinet expertise and support.
- d. Technical staff shall attend traffic signal "turn-on" and inspection with a minimum 14 calendar day notice.

SUBMITTALS

Revise Article 801.05 of the Standard Specifications to read:

All material approval requests shall be submitted electronically. The submittal shall be by email, and shall include a cover letter and one PDF file with all pay items for the project.

General requirements include:

- a. All material approval requests shall be submitted within 7 calendar days after the preconstruction meeting. Traffic signal materials and equipment shall bear the U.L. label whenever such labeling is available.
- b. Product data and shop drawings shall be arranged by pay item. Pages of the submittal should be numbered.
- c. When hard copy submittals are necessary for another agency, four complete copies of the manufacturer's descriptive literatures and technical data for the traffic signal materials will be submitted, in addition to the electronic copy required above. If the literature contains more than one item, the Contractor shall indicate which item or items will be furnished.
- d. When hard copy submittals are necessary for structural elements, four complete copies of the shop drawings for the mast arm assemblies and poles, and the combination mast arm assemblies and poles showing, in detail, the fabrication thereof and the certified mill analyses of the materials used in the fabrication, anchor rods, and reinforcing materials, shall be submitted, in addition to the electronic copy required above.
- e. Partial or incomplete submittals will be returned without review.
- f. Certain non-standard mast arm poles and structures will require additional review from IDOT's Bureau of Bridges and Structures. Examples include special mast arms and non-standard length mast arm pole assemblies. The Contractor shall account for the additional review time in their schedule.
- g. The County Section Number, permit number, or IDOT contract number, project location/limits and corresponding pay code number shall be on each sheet of correspondence, catalog cuts and mast arm poles and assemblies drawings.
- h. Where certifications and/or warranties are specified, the information submitted for approval shall include certifications and warranties. Certifications involving inspections, and/or tests of material shall include all test data, dates, and times.
- i. The Contractor shall secure approved materials in a timely manner to assure construction schedules are not delayed.

- j. After the Traffic Engineer reviews the submittals for conformance with the design concept of the project, the drawings will be stamped indicating their status as 'APPROVED', 'APPROVED AS CORRECTED', 'NOT APPROVED', or 'RESUBMIT'. Review schedule will be according to Article 801.05(b). Since the Traffic Engineer's review is for conformance with the design concept only, it is the Contractor's responsibility to coordinate the various items into a working system as specified. The Contractor shall not be relieved from responsibility for errors or omissions in the shop, working, layout drawings, or other documents by the Traffic Engineer's approval thereof.
- k. For contracts let through the Illinois Department of Transportation, the Contractor shall forward all stamped submittals to IDOT's Bureau of Local Roads and Streets upon completion of the review and approval process by LCDOT.
- l. All submitted items reviewed and marked 'APPROVED AS CORRECTED', 'NOT APPROVED', or 'RESUBMIT' shall be resubmitted in their entirety, unless otherwise indicated within the submittal comments, with a disposition of previous comments to verify Contract compliance at no additional cost to the contract.
- m. It is the Contractor's responsibility to note any deviations from Contract requirements at the time of submittal and to make any requests for deviations in writing to the Resident Engineer. In general, substitutions will not be acceptable. Requests for substitutions shall demonstrate that the proposed substitution is superior to the material or equipment required by the Contract Documents. No exceptions, deviations or substitutions will be permitted without the approval of the Resident Engineer.
- n. The Contractor shall not order major equipment (i.e., mast arm assemblies) prior to Resident Engineer approval of the Contractor marked proposed traffic signal equipment locations to assure proper placement of Contract required traffic signal displays, push buttons and other facilities. Field adjustments may require changes in proposed mast arm length and other coordination.

MARKING PROPOSED LOCATIONS

Revise "Marking Proposed Locations for Highway Lighting System" of Article 801.09 to read "Marking Proposed Locations for Highway Lighting System and Traffic Signals."

Add the following to Article 801.09 of the Standard Specifications:

It shall be the Contractor's responsibility to verify all dimensions and conditions existing in the field prior to ordering materials and beginning construction. This shall include locating the mast arm foundations and verifying the mast arms lengths.

INSPECTION OF ELECTRICAL SYSTEMS

Add the following to Article 801.10 of the “Standard Specifications”:

- (c) All cabinets, including temporary traffic signal cabinets, shall be assembled by an approved Equipment Supplier in District 1. LCDOT reserves the right to request that any controller and cabinet be tested at a District 1 approved Equipment Supplier’s facility prior to field installation. Such testing will be at no extra cost to the contract. All permanent or temporary "railroad interconnected” controllers and cabinets, shall be new, built, tested and approved by the controller Equipment Supplier, in the Equipment Supplier’s District 1 approved facility, prior to field installation. The Equipment Supplier shall provide the technical equipment and assistance as required by the Traffic Engineer to fully test this equipment.

LIQUIDATED DAMAGES FOR UNTIMELY WORK

A primary concern of LCDOT is to maintain a safe and efficient roadway for the public. Therefore, the Contractor shall proceed with the traffic signal work as soon as conditions and project staging permit. If in the opinion of the Traffic Engineer construction conditions are suitable for traffic signal work, and the Contractor has not yet begun the traffic signal work, the Resident Engineer shall notify the Contractor to proceed. The Contractor shall begin the traffic signal work within seven calendar days after notification to proceed. The Contractor shall continue to prosecute the traffic signal work until completion, or until he can no longer proceed due to conditions beyond their control. The Contractor shall notify the Resident Engineer of any conditions impeding and/or delaying their prosecution of the work. Failure by the Contractor to proceed with the traffic signal work as specified herein shall result in liquidated damages of **\$500.00** per calendar day per occurrence.

For projects involving detector loop installations or replacement, the following additional conditions apply. If in the opinion of the Traffic Engineer, construction conditions are suitable for loop installation(s), the Resident Engineer shall notify the Contractor to proceed. The detector loops shall be installed and fully operational within 14 calendar days following notification to proceed by the Resident Engineer. This 14-day period shall be in effect throughout the entire year, including the off season, regardless of the Contractor's working day status. Failure by the Contractor to complete the loop installation(s) within the specified timeframe shall result in liquidated damages in the amount of **\$500.00** per calendar day, per intersection.

MAINTENANCE AND RESPONSIBILITY

Revise Article 801.11 of the “Standard Specifications” to read:

- a. Existing traffic signal installations and/or any electrical facilities at locations included in this Contract may be altered or reconstructed totally or partially as part of the work on this contract. The Contractor is hereby advised that all traffic control equipment presently installed at these locations may be the property of the County of Lake, State of Illinois, Department of Transportation, Division of Highways, County, Transit Agency, Private Developer, or the Municipality in which it is located. Once the Contractor has begun any work on any portion of the project, all traffic signals within the limits of this Contract that have the pay item MAINTENANCE OF EXISTING TRAFFIC SIGNAL INSTALLATION, TEMPORARY TRAFFIC SIGNAL INSTALLATION, and/or MAINTENANCE OF EXISTING FLASHING BEACON INSTALLATION, shall become the full responsibility of the Contractor. The Contractor shall supply the Resident Engineer and the County’s Traffic Signal Maintenance Contractor one 24-hour emergency contact name and telephone number. The Contractor shall provide sufficient qualified personnel to respond to all notifications of malfunctions on a round-the-clock basis (24 hours a day, 7 days a week). The Contractor is required to keep a time and date log of all maintenance items, including the time of the initial report, the response time, and the time of final permanent repair. The Contractor shall provide this information to the Resident Engineer, upon request.
- b. When the project has a pay item for MAINTENANCE OF EXISTING TRAFFIC SIGNAL INSTALLATION, TEMPORARY TRAFFIC SIGNAL INSTALLATION, and/or MAINTENANCE OF EXISTING FLASHING BEACON INSTALLATION, the Contractor shall notify the Traffic Engineer at **(847) 377-7000** of their intent to begin any physical construction work on the project. This notification shall be a minimum of ten calendar days prior to the start of construction to allow sufficient time for an inspection of the existing traffic signal installation(s) and the transfer of maintenance to the Contractor. If work is started prior to the inspection, maintenance of the traffic signal installation(s) will be immediately transferred to the Contractor without an inspection. The Contractor shall then become responsible for repairing or replacing all equipment that is not operating properly or is damaged at no cost to the owner of the traffic signal. Final repairs to or the replacement of damaged equipment shall meet the approval of the Traffic Engineer at the time of final inspection or the traffic signal installation will not be accepted.
- c. Automatic Traffic Enforcement equipment including red lighting running and railroad crossing camera systems are owned and operated by others. The Contractor shall not be responsible for maintaining this equipment. This equipment shall be de-activated while the traffic signal is on Contractor maintenance. The Contractor shall notify the municipality of the equipment de-activation.
- d. LCDOT, regional transit, IDOT, and other agencies may also have equipment connected to existing traffic signal or peripheral equipment including PTZ cameras, switches, transit

signal priority (TSP and BRT) servers and other devices that shall be included with traffic signal maintenance at no additional cost to the contract.

- e. For contracts that include pay items for milling or pavement patching that may result in destruction of loop detectors, but do not include installation or modification of the traffic signals, maintenance transfers are not required. These contracts do require a notification of intent to work and an inspection. A minimum of ten calendar days prior to the loop removal, the Contractor shall notify the Traffic Engineer at **(847) 377-7000**, at which time arrangements will be made to adjust the traffic controller timing to compensate for the absence of detection.
- f. The Contractor is advised that the existing and/or temporary traffic signal installation shall remain in operation during all construction stages, except for the most unavoidable down time. Any plan to shut down the traffic signal installation for a period exceeding 15 minutes shall receive prior approval from the Traffic Engineer. Approval to shut down the traffic signal installation will only be granted during the hours of 9:00 A.M. to 3:00 P.M. on weekdays. Shutdowns will not be allowed during inclement weather, weekends or holiday periods.
- g. The Contractor shall be fully responsible for the safe and efficient operation of the traffic signals. Any inquiry, complaint or request by LCDOT, the County's Traffic Signal Maintenance Contractor or the public, shall be investigated and repairs started. The Contractor shall restore service and complete permanent repairs according to the following Repair Timetable. Failure to provide this service will result in liquidated damages of **\$500** per calendar day per occurrence. The Traffic Engineer reserves the right to assign any work not completed within this timeframe to the County's Traffic Signal Maintenance Contractor. All costs associated with the completion of the uncompleted repair shall be the responsibility of the Contractor. Failure to pay these costs to the Traffic Signal Maintenance Contractor within one month after the incident will result in additional liquidated damages of \$500 per month per occurrence. Unpaid bills will be deducted from the cost of the Contract. County personnel, the County's Traffic Signal Maintenance Contractor, and the County's PASSAGE Consultant may inspect any signalizing device on LCDOT's highway system at any time without notification.
- h. Any proposed activity in the vicinity of a highway-rail grade crossing shall adhere to the guidelines set forth in the current edition of the Manual on Uniform Traffic Control Devices (MUTCD) regarding work in temporary traffic control zones in the vicinity of highway-rail grade crossings which states that lane restrictions, flagging, or other operations shall not create conditions where vehicles can be queued across the railroad tracks. If the queuing of vehicles across the tracks cannot be avoided, a uniformed law enforcement officer or flagger shall be provided at the crossing to prevent vehicles from stopping on the tracks, even if automatic warning devices are in place.
- i. At signals where the Contractor is responsible for maintenance, including temporary traffic signals and newly constructed traffic signals that are not yet accepted by the County, the Contractor shall be responsible for clearing snow, ice, dirt, debris or other

condition that obstructs visibility of any traffic signal display or access to traffic signal equipment in compliance with the REPAIR TIMETABLE. Two clearly visible signal indications of all colors and arrows are required to be maintained at all time.

- j. In the event of power loss at locations where the Contractor is responsible for maintenance, including temporary traffic signals and newly constructed traffic signals that are not yet accepted by the County, the Contractor shall be responsible for working with Lake County personnel to make connections of portable County-supplied generators at the maintained location, as directed by the Traffic or Resident Engineer.

Immediately after performing any work related to a signal maintenance item (troubleshooting, temporary repair, permanent repair, etc.) the Contractor shall contact the Lake County PASSAGE Transportation Management Center (TMC) at **(847) 377-7000**.

All items shall be repaired within the time frame described in the Repair Timetable. The times listed are noncumulative. Any repairs not specifically covered in the Repair Timetable, or described elsewhere, shall be completed within a time frame matching the most similar line item in the Repair Timetable.

REPAIR TIMETABLE
 (non cumulative)

<u>ITEM</u>	<u>RESPONSE</u> <u>TIME</u>	<u>SERVICE</u> <u>RESTORATION</u>	<u>PERMANENT</u> <u>REPAIRS</u>
KNOCKDOWNS/FAILURE/DAMAGE:			
Cabinet	1 hr	24 hrs	2 wks
Controller (Local or Master)	1 hr	24 hrs	2 wks
Adaptive Control Hardware	1 hr	24 hrs	3 wks
Detector Loop/Magnetometer	1 hr	n.a.	2 wks
Loop Detector/Amplifier	1 hr	4 hrs	2 wks
Video Detection Camera	1 hr	4 hrs	2 wks
PTZ Camera	2 hrs	48 hrs	2 wks
Detector Interface Card/Mini Hub	1 hr	4 hrs	2 wks
Modem	2 hrs	NWD	2 wks
Load Switch	1 hr	2 hrs	2 hrs
Signal Head/Lenses	1 hr	2 hrs	NWD
Pole/Mast Arm	1 hr	2 hrs	ENG
Cabling/Conduit	1 hr	4 hrs	ENG
Interconnect/Communication	1 hr	NWD	ENG
Graffiti/Advertising	NWD	NWD	NWD
Telemetry, Electrical	1 hr	2 hrs	NWD
Ethernet Switches/Video Encoders	1 hr	48 hrs	2 wks
Highway Advisory Radio (HAR)	1 hr	48 hrs	2 wks
Indicators/switches/LEDs/displays	NWD	n.a.	2 wks
Snow/Ice/Debris/Other Obstructions	1 hr	2 hrs	NWD
Outages not covered elsewhere	1 hr	2 hrs	NWD
Filter/Cleanliness/fans/thermostat	NWD	NWD	n.a.
Misalignment (conflicting)	1 hr	2 hrs	NWD
Misalignment (non-conflicting)	2 hrs	4 hrs	NWD
COMPLAINTS/CALLS/ALARMS:			
Timing/Phasing/Programming	1 hr	2 hrs	ENG
Coordination Alarm/Cycle Fail	NWD	ENG	ENG
Controller Alarm/Status Change	1 hr	NWD	1 wk
Detector Alarm/Status change	NWD	NWD	ENG
UPS	1 hr	2 hrs	2 wks
CMU Flash/Local Flash	1 hr	2 hrs	1 wk
Door Open/Maint. Req.	1 hr	4 hrs	NWD

LEGEND: hr=hour, hrs=hours, NWD=next week day, days=calendar days,
 ENG=acceptable to Traffic Engineer, wk=week, wks=weeks, n.a.=not applicable

MODIFICATION OF IDOT SPECIAL PROVISION REQUIREMENTS

When IDOT Special Provisions for traffic signal items are included in an LCDOT Contract or Permit project, the following modifications shall apply to the noted Special Provisions.

Contact Information: The Contractor shall utilize the LCDOT contact information for LCDOT projects in place of the personnel, phone numbers, and directives provided in the following District 1 Special Provisions when they are included in the Contract:

- 800.02TS Optimize Signal System
- 800.03TS Re-Optimize Signal System
- 805.01TS Electric Service Installation
- 886.01TS Detector Loop
- 890.01TS Temporary Traffic Signal Installation
- 890.02TS Temporary Traffic Signal Timing

All references in the above special provisions to Traffic Signal Engineer, Area Traffic Signal Engineer, Area Traffic Signal Maintenance and Operations Engineer, Bureau of Traffic Operations, Traffic Operations Engineer, State, State's Traffic Signal Maintenance Contractor, and State's Electrical Maintenance Contractor shall be replaced with the LCDOT Traffic Engineer and the phone number shall be **847-377-7000**. Submittals, requests for reviews, scheduling of appointments, and requests for materials and information shall be directed to the LCDOT Traffic Engineer instead of IDOT, District 1, or the State's Maintenance Contractor.

Traffic Signal Timing Consultant Requirements: Add the following paragraph to the following District 1 Special Provisions:

- 800.02TS Optimize Signal System
- 800.03TS Re-Optimize Signal System
- 890.02TS Temporary Traffic Signal Timing

All work shall be based upon the LCDOT Countywide Synchro model. The Consultant shall contact the Traffic Engineer at **847-377-7000** to acquire the required portion of the countywide model to be updated for the particular project. Upon completion of the project, the Consultant shall provide LCDOT with the revised and updated files for inclusion into the Countywide Synchro Model. Graphics displays for LCDOT's traffic signal systems do not need to be furnished to LCDOT.

Pedestrian Pushbutton Station Requirements: Add the following paragraph to the following District 1 Special Provision:

888.01 TS Pedestrian Push Button

The pedestrian push button signs shall be retroreflective R10-3, 9"x12" signs displaying the "Push Button For" legend with the Walking Man symbol and arrow, unless shown otherwise in the plans. The pedestrian push button station shall be natural, unfinished aluminum with rounded corners sized to accommodate the 9"x12" sign.

DAMAGE TO TRAFFIC SIGNAL SYSTEM

Revise Article 801.12(b) of the "Standard Specifications" to read:

Any traffic control equipment damaged or not operating properly from any cause whatsoever shall be repaired and/or replaced. All inoperable components shall be replaced with new equipment meeting the special provisions or the current LCDOT requirements. The Contractor shall provide replacement components at no additional cost to the Contract and/or owner of the traffic signal system. Final repairs or replacement of damaged equipment shall meet the approval of the Traffic Engineer prior to or at the time of final inspection; otherwise the traffic signal installation will not be accepted. Cable splices outside the controller cabinet shall not be allowed, unless approved by the Traffic Engineer.

Temporary replacement of damaged or knocked down mast arm pole assembly shall require construction of a full or partial span wire signal installation or other method approved by the Traffic Engineer.

Automatic Traffic Enforcement equipment, including Red Light Enforcement cameras, detectors, and peripheral equipment, damaged or not operating properly from any cause whatsoever, shall be the responsibility of the municipality or the Automatic Traffic Enforcement company per Permit agreement.

VIDEO AND NETWORK SYSTEM REQUIREMENTS

For all projects including installation or relocation of video and/or network equipment, the Contractor shall contact the TMC at **847-377-7000** after installation to confirm proper operation of the equipment within the PASSAGE system. This includes confirming that the camera horizon is properly adjusted, camera lens is clear, network settings are correct and all devices are communicating correctly with the TMC. For equipment requiring an IP address or other LCDOT assigned parameters, the Contractor should request the information from the TMC a minimum of one week in advance of the traffic signal "turn-on." The Contractor shall be responsible for making any changes necessary to the camera mounting, aiming, and/or equipment programming to meet the PASSAGE requirements and/or to operate the equipment to the satisfaction of the Traffic Engineer. Contacting the TMC for confirmation of equipment operation does not constitute an installation review and does not relieve the Contractor of the responsibility to correct deficiencies identified at the "turn-on." The cost of meeting these requirements shall be included in the associated pay item and no additional compensation shall be made. Calls to the TMC shall be made according to the PASSAGE System Support section of this special provision.

TRAFFIC SIGNAL INSPECTION (“TURN-ON”)

Revise Article 801.15(b) of the “Standard Specifications” to read:

It is LCDOT’s intent to have all electric work completed and the equipment field-tested by the Equipment Supplier, prior to LCDOT’s "turn-on" field inspection. The Contractor shall have all traffic signal work completed and the electrical service installation connected by the utility company prior to requesting an inspection and “turn-on” of the traffic signal installation. In the event the Traffic Engineer determines that the work is not complete and that the inspection will require more than two hours to complete, the inspection may be cancelled and the Contractor will be required to reschedule at another date.

The Contractor may request a “turn-on” and inspection of the completed traffic signal installation at each separate location. This request shall be made to the Traffic Engineer at **(847) 377-7000** a minimum of ten calendar days prior to the time of the requested inspection. When the Contract includes the pay item RE-OPTIMIZE TRAFFIC SIGNAL SYSTEM, OPTIMIZE TRAFFIC SIGNAL SYSTEM, or TEMPORARY TRAFFIC SIGNAL TIMINGS, the Contractor shall notify the Signal Coordination and Timing (SCAT) Consultant of the “turn-on”/detour implementation schedule, as well as stage changes and signal phase changes during construction. The SCAT Consultant shall be in attendance at each temporary and permanent traffic signal “turn-on.”

The Contractor shall provide a representative from the Equipment Supplier’s office to attend the traffic signal inspection for both permanent and temporary traffic signal "turn-ons." Signal indications being tested shall match the lane configurations and markings at the intersection. If any conflicting signal indications are visible to motorist or pedestrians while testing, the Contractor shall be responsible to provide police officer(s) to direct traffic.

Upon demonstration that the signals are operating properly according to the Contract and to the satisfaction of the Traffic Engineer, the Traffic Engineer will allow the signals to be placed in continuous operation. The Traffic Engineer will inspect the traffic signal installation, with the assistance of the Contractor, and provide a written “punch-list” of deficient items requiring completion. The Contractor shall complete all “punch-list” work within 30 calendar days of notification. If this work is not completed within 30 days, LCDOT reserves the right to have the work completed by others at the Contractor’s expense. This cost will be in addition to Liquidated Damages for Untimely Work.

The Contractor shall furnish all equipment and/or parts to keep the traffic signal installation operating. The Contractor shall be responsible for all traffic signal equipment and associated maintenance thereof until LCDOT acceptance is granted.

When the Contractor has completed the “punch-list” work, he/she shall contact the Traffic Engineer to schedule a follow-up inspection of the traffic signal installation. If the Traffic Engineer determines that any “punch-list” items have not been completed, he may cancel the inspection, and the Contractor will need to reschedule.

It is possible that during any follow-up inspections of the traffic signal installation, deficient items may be identified that were not identified at the “turn-on” inspection, or included in the initial “punch-list”. The Traffic Engineer shall advise the Contractor of any such items, and it shall be the Contractor’s responsibility to complete these items prior to acceptance of the traffic signal.

Acceptance of the traffic signal by LCDOT shall be based on the inspection results and successful operation during a minimum 72-hour “burn-in” period following activation of the traffic signal and related equipment. Therefore, due to the required “burn-in” period, acceptance of the traffic signal shall not occur at the time of the “turn-on.” Upon notification by the Contractor that all noted deficiencies have been corrected, and after the “burn-in” period, the Traffic Engineer shall perform an acceptance inspection of the traffic signal installation. If approved, the traffic signal acceptance shall be given verbally at the inspection, followed by written correspondence from the Traffic Engineer. The Agency that is responsible for the maintenance of each traffic signal installation will assume the traffic signal maintenance upon acceptance by the Traffic Engineer.

LCDOT requires the following Final Project Documentation from the Contractor prior to acceptance of the traffic signal. The documentation shall be provided in hard copy and electronic format as indicated below.

1. One copy (11”x17”) and one electronic PDF file of as-built signal plans with field revisions marked in red.
2. One copy of the operation and service manuals for the signal controller and the associated control equipment.
3. Five copies (11"x17") and one electronic PDF file of the cabinet wiring diagrams.
4. Five copies and one electronic PDF file of the traffic signal installation cable log.
5. All manufacturer and Contractor warranties and guarantees required by Article 801.14 of the Standard Specifications.

All cost of work and materials required to comply with the above requirements shall be included in the pay item bid prices, under which the subject materials and signal equipment are paid, and no additional compensation will be allowed. Materials and signal equipment not complying with the above requirements will be subject to removal and disposal at the Contractor's expense.

LOCATING UNDERGROUND FACILITIES

Revise Section 803 of the “Standard Specifications” to read:

Once the Contractor has taken maintenance of an existing County facility or has constructed underground facilities, they are responsible for locating the facilities according the J.U.L.I.E. requirements at no additional cost to the Contract.

Contractor requests for equipment locates will be granted only once prior to the start of construction. Additional requests shall be at the expense of the Contractor. The location of underground traffic facilities does not relieve the Contractor of their responsibility to repair any item(s) damaged during the construction, at his/her own expense.

Locate requests shall be directed to LCDOT's Traffic Signal Maintenance Contractor or to the LCDOT Traffic Engineering Department at **(847) 377-7000**.

The exact location of all utilities shall be field verified by the Contractor before the installation of any components of the traffic signal system. For locations of utilities call J.U.L.I.E. at **1-800-892-0123**. The location of some utilities may require contacting other Agencies or Municipalities.

The Contractor should note that IDOT does not participate in J.U.L.I.E. Underground work that is proposed to take place within IDOT right-of-way requires the Contractor to contact IDOT for the procedures involved in locating their facilities.

RESTORATION OF WORK AREA

Add to Section 801 of the "Standard Specifications":

Restoration of the traffic signal work area shall be included in the related pay item including foundation, conduit, handhole, trench and backfill, etc. and no extra compensation shall be allowed. All roadway surfaces including shoulders, medians, sidewalks, pavement, etc. shall be restored to match the previously existing conditions. All damage to mowed lawns shall be replaced with an approved sod, and all damage to unmowed fields shall be seeded, according to Section 250 and Section 252 of the Standard Specifications respectively, except that Phosphorus fertilizer nutrient shall not be used on Lake County Highways or within Lake County right-of-way, and a knitted straw mat shall be applied to seeded areas, according to Article 1081.10 (b) of the Standard Specifications. Areas in front of residences are to be restored within two weeks of the completion of work causing the disturbance regardless of the duration of the project remaining. The traffic signal work area includes any area where the Contractor or their subcontractors perform work to install, repair, or maintain County owned traffic, lighting, or PASSAGE equipment, regardless of the presence of an actual traffic signal.

CABINET NEATNESS AND WIRING

The Contractor shall ensure that all wiring and peripheral equipment in any new traffic signal cabinet is in a neat and orderly fashion that is acceptable to the Traffic Engineer. This applies to controller cabinets, master cabinets, railroad cabinets, communication cabinets, electrical service cabinets, or any other new cabinet called for in the project plans.

All conduit entrances into the cabinet shall be sealed with a pliable waterproof material. Electrical cables inside the cabinet shall be neatly trained along the base and back of the cabinet. Each conductor shall be connected individually to the proper terminal. The spare conductors shall be bound into a neat bundle. All cables, including those for signals, vehicle detection, pushbuttons, emergency vehicle preemption, video transmission, and communication shall be neatly arranged and bundled within the cabinet to the satisfaction of the Traffic Engineer. Each

cable shall be marked with an identification number which corresponds to the number and description on the cabinet cable log.

When modernizing or modifying an existing cabinet, the new cables being installed shall be trained, bundled, and labeled to the satisfaction of the Traffic Engineer. When working inside an existing cabinet, the Contractor shall minimize disturbance to existing cables and cabinet wiring. Any existing cables and cabinet wiring disturbed by the Contractor shall be re-trained, bundled, and/or labeled to the satisfaction of the Traffic Engineer.

Unless indicated elsewhere in the plans and specs, all equipment in the cabinet shall be wired through the UPS except lighted street name signs and luminaires.

Components with Ethernet capabilities shall be connected to the Switch or other communications equipment in the cabinet as directed by the Traffic Engineer. All equipment, materials, labor and hardware, including Ethernet patch cables, required to provide cabinet neatness and wiring to the satisfaction of the Traffic Engineer shall be included in the applicable pay item for FULL ACTUATED CONTROLLER AND TYPE IV CABINET SPECIAL, FULL-ACTUATED CONTROLLER IN EXISTING CABINET, and/or MODIFY EXISTING CONTROLLER.

The County shall not accept maintenance of the traffic signal installations until the requirements of this specification are satisfied.

EQUIPMENT SUPPLIER AND VENDOR REPRESENTATION

The Traffic Engineer reserves the right to request a representative of the Equipment Supplier and/or Vendor be present at the activation of new traffic equipment. The traffic equipment may include signal heads, cabinets, controllers, amplifiers, preemption, detection, monitoring, communication/transmission, fiber-optic/telemetry, radio, microwave, infrared, illuminated signs, streetlights, push buttons, lighted crosswalks, uninterruptable power supplies, adaptive, counters, and any other new equipment being installed and activated. The representative shall be a qualified technician trained in the proper installation and operation of the equipment being installed under the Contract or permit.

The Traffic Engineer reserves the right to cancel the “turn-on,” transfer, or other scheduled activity if, in their opinion, knowledgeable personnel from the Equipment Supplier or Vendor are not present. Rescheduling, and any associated costs, shall be the responsibility of the Contractor, and shall be subject to availability of LCDOT Traffic staff.

This provision is in addition to the requirement contained herein that the Contractor provide a representative from the Equipment Supplier to attend the traffic signal inspection for both permanent and temporary traffic signal “turn-on”.

Any costs associated with Equipment Supplier and/or Vendor representation shall be included in the unit price of the associated traffic equipment being activated. Any unforeseen costs incurred by the Contractor to provide this representation shall not be the responsibility of the County.

INTERRUPTION OF COMMUNICATION

The interruption of communication with County equipment shall be kept to an absolute minimum. Communication includes controller telemetry, video transmission, camera control signals, Highway Advisory Radio, wireless interconnect, telephone (POTS/ISDN/DSL), high speed Internet, cellular modem, or any other County communication equipment. This provision applies to cable types including copper, multimode fiber optic, singlemode fiber optic, telephone cables, Ethernet cables, or any other cable used by the County to monitor and maintain its various signal and ITS equipment.

The Contractor shall plan ahead, and shall stage their construction work accordingly, so that he/she can interrupt communication, and then restore communication, with as little down time as possible. For example, when a section of existing interconnect is being relocated, the new handholes and conduits should be installed prior to disconnecting the interconnect cable. The interconnect cable can then be disconnected, pulled out of the existing conduit, pulled through the new conduit, and re-connected. In addition, when an existing fiber optic cable is to be re-used, the Contractor shall be prepared to immediately replace any fiber splices and/or terminations that become damaged.

Prior to disconnecting any LCDOT communication link, the Contractor shall contact the Traffic Engineer for approval of their planned construction method.

PASSAGE SYSTEM SUPPORT

The LCDOT PASSAGE TMC staff are available to provide a limited amount of technical support to the Contractor between the hours of 8:00 AM and 4:30 PM. The Contractor may request the TMC staff provide configuration information, settings, and testing support, and other items approved by the Traffic Engineer. Due to the primary responsibility of PASSAGE staff to maintain traffic flow in Lake County during peak hours, requests that require LCDOT support after 4:30 PM may not be honored until the next business day. Extensions to the Contract working days or completion date will not be authorized solely due to requests for support that do not meet these requirements.

OPTIMIZE TRAFFIC SIGNAL SYSTEM

Effective: May 22, 2002

Revised: July 1, 2015

800.02TS

Description.

This work shall consist of optimizing a closed loop traffic signal system.

OPTIMIZE TRAFFIC SIGNAL SYSTEM applies when a new or existing closed loop traffic signal system is to be optimized and a formal Signal Coordination and Timing (SCAT) Report is to be prepared. The purpose of this work is to improve system performance by optimizing traffic signal timings, developing a time of day program and a traffic responsive program.

After the signal improvements are completed, the signal system shall be optimized as specified by an approved Consultant who has previous experience in optimizing Closed Loop Traffic Signal Systems for District One of the Illinois Department of Transportation. The Contractor shall contact the Traffic Signal Engineer at (847) 705-4424 for a listing of approved Consultants. Traffic signal system optimization work, including fine-tuning adjustments of the optimized system, shall follow the requirements stated in the most recent IDOT District 1 SCAT Guidelines, except as noted herein.

A listing of existing signal equipment, interconnect information, phasing data, and timing patterns may be obtained from the Department, if available and as appropriate. The existing SCAT Report is available for review at the District One office and if the Consultant provides blank a CD, copies of computer simulation files for the existing optimized system and a timing database that includes intersection displays will be made for the Consultant. The Consultant shall confer with the Traffic Signal Engineer prior to optimizing the system to determine if any extraordinary conditions exist that would affect traffic flows in the vicinity of the system, in which case, the Consultant may be instructed to wait until the conditions return to normal or to follow specific instructions regarding the optimization.

(a) The following tasks are associated with OPTIMIZE TRAFFIC SIGNAL SYSTEM.

1. Appropriate signal timings and offsets shall be developed for each intersection and appropriate cycle lengths shall be developed for the closed loop signal system.
2. Traffic counts shall be taken at all intersections after the permanent traffic signals are approved for operation by the Area Traffic Signal Operations Engineer. Manual turning movement counts shall be conducted from 6:30 a.m. to 9:30 a.m., 11:00 a.m. to 1:00 p.m., and 3:30 p.m. to 6:30 p.m. on a typical weekday from midday Monday to midday Friday and on a Saturday or Sunday, as directed by the Engineer, to account for special traffic generators such as shopping centers, educational institutes and special event facilities. The turning movement counts shall identify cars, and single-unit and multi-unit heavy vehicles.
3. As necessary, the intersections shall be re-addressed and all system detectors reassigned in the master controller according to the current standard of District One.

4. A traffic responsive program shall be developed, which considers both volume and occupancy. A time-of-day program shall be developed for used as a back-up system.
 5. Proposed signal timing plan for the new or modified intersection shall be forwarded to IDOT for review prior to implementation.
 6. Consultant shall conduct on-site implementation of the timings and make fine-tuning adjustments to the timings in the field to alleviate observed adverse operating conditions and to enhance operations. The consultant shall respond to IDOT comments and public complaints for a minimum period of 90 days from date of timing plan implementation.
 7. Speed and delay studies shall be conducted during each of the count periods along the system corridor in the field before and after implementation of the proposed timing plans for comparative evaluations. These studies should utilize specialized electronic timing and measuring devices.
- (b) The following deliverables shall be provided for OPTIMIZE TRAFFIC SIGNAL SYSTEM.
1. Consultant shall furnish to IDOT one (1) copy of a SCAT Report for the optimized system. The SCAT Report shall include the following elements:

Cover Page in color showing a System Map
Figures <ol style="list-style-type: none"> 1. System overview map – showing system number, system schematic map with numbered system detectors, oversaturated movements, master location, system phone number, cycle lengths, and date of completion. 2. General location map in color – showing signal system location in the metropolitan area. 3. Detail system location map in color – showing cross street names and local controller addresses. 4. Controller sequence – showing controller phase sequence diagrams.
Table of Contents
Tab 1: Final Report <ol style="list-style-type: none"> 1. Project Overview 2. System and Location Description (Project specific) 3. Methodology 4. Data Collection 5. Data Analysis and Timing Plan Development 6. Implementation <ol style="list-style-type: none"> a. Traffic Responsive Programming (Table of TRP vs. TOD Operation) with am, md, and pm cycle lengths 7. Evaluation <ol style="list-style-type: none"> a. Speed and Delay runs
Tab 2. Turning Movement Counts <ol style="list-style-type: none"> 1. Turning Movement Counts (Showing turning movement counts in the intersection diagram for each period, including truck percentage)
Tab 3. Synchro Analysis <ol style="list-style-type: none"> 1. AM: Time-Space diagram in color, followed by intersection Synchro report (Timing report) summarizing the implemented timings. 2. Midday: same as AM 3. PM: same as AM 4. Special weekend or off-peak traffic generators (shopping centers, educational facilities, arenas, etc.): same as AM
Tab 4: Speed, Delay Studies <ol style="list-style-type: none"> 1. Summary of before and after runs results in two (2) tables showing travel time and delay time. 2. Plot of the before and after runs diagram for each direction and time period.
Tab 5: Environmental Report <ol style="list-style-type: none"> 1. Environmental impact report including gas consumption, NO2, HCCO, improvements.
Tab 6: Electronic Files <ol style="list-style-type: none"> 1. Two (2) CDs for the optimized system. The CDs shall include the following elements: <ol style="list-style-type: none"> a. Electronic copy of the SCAT Report in PDF format b. Copies of the Synchro files for the optimized system c. Traffic counts for the optimized system

- d. New or updated intersection graphic display files for each of the system intersections and the system graphic display file including system detector locations and addresses.

Basis of Payment.

The work shall be paid for at the contract unit each for OPTIMIZE TRAFFIC SIGNAL SYSTEM, which price shall be payment in full for performing all work described herein for the entire traffic signal system. Following the completion of traffic counts, 25 percent of the bid price will be paid. Following the completion of the Synchro analysis, 25 percent of the bid price will be paid. Following the setup and fine tuning of the timings, the speed-delay study, and the TRP programming, 25 percent of the bid price will be paid. The remaining 25 percent will be paid when the system is working to the satisfaction of the engineer and an approved report and CD have been submitted.

SERVICE INSTALLATION (TRAFFIC SIGNALS)

Effective: May 22, 2002

Revised: June 15, 2016

805.01TS

Revise Section 805 of the Standard Specifications to read:

Description.

This work shall consist of all materials and labor required to install, modify, or extend the electric service installation. All installations shall meet the requirements of the “District One Standard Traffic Signal Design Details”.

General.

The electric service installation shall be the electric service disconnecting means and it shall be identified as suitable for use as service equipment.

The electric utility contact information is noted on the plans and represents the current information at the time of contract preparation. The Contractor must request in writing for service and/or service modification within 10 days of contract award and must follow-up with the electric utility to assure all necessary documents and payment are received by the utility. The Contractor shall forward copies of all correspondence between the contractor and utility company to the Engineer and Area Traffic Signal Maintenance and Operations Engineer. The service agreement and sketch shall be submitted for signature to the IDOT’s Traffic Operations Programs Engineer.

Materials.

- a. General. The completed control panel shall be constructed in accordance with UL Std. 508A, Industrial Control Panel, and carry the UL label. Wire terminations shall be UL listed.
- b. Enclosures.
 1. Pole Mounted Cabinet. The cabinet shall be UL 50, NEMA Type 4X, unfinished single door design, fabricated from minimum 0.080-inch (2.03 mm) thick Type 5052 H-32 aluminum. Seams shall be continuous welded and ground smooth. Stainless steel screws and clamps shall secure the cover and assure a watertight seal. The cover shall be removable by pulling the continuous stainless steel hinge pin. The cabinet shall have an oil-resistant gasket and a lock kit shall be provided with an internal O-ring in the locking mechanism assuring a watertight and dust-tight seal. The cabinet shall be sized to adequately house all required components with extra space for arrangement and termination of wiring. A minimum size of 14-inches (350 mm) high, 9-inches (225 mm) wide and 8-inches (200 mm) in depth is required. The cabinet shall be channel mounted to a wooden utility pole using assemblies recommended by the vendor.

2. Ground Mounted Cabinet. The cabinet shall be UL 50, NEMA Type 3R unfinished single door design with back panel. The cabinet shall be fabricated from Type 5052 H-32 aluminum with the frame and door 0.125-inch (3.175 mm) thick, the top 0.250-inch (6.350 mm) thick and the bottom 0.500-inch (12.70 mm) thick. Seams shall be continuous welded and ground smooth. The door and door opening shall be double flanged. The door shall be approximately 80% of the front surface, with a full length tamperproof stainless steel .075-inch (1.91 mm) thick hinge bolted to the cabinet with stainless steel carriage bolts and nylocks nuts. The locking mechanism shall be slam-latch type with a keyhole cover. The cabinet shall be sized to adequately house all required components with extra space for arrangement and termination of wiring. A minimum size of 40-inches (1000 mm) high, 16-inches (400 mm) wide and 15-inches (375 mm) in depth is required. The cabinet shall be mounted upon a square Type A concrete foundation as indicated on the plans. The foundation is paid for separately.
3. All enclosures shall include a green external power indicator LED light with circuitry as shown in the Electrical Service-Panel Diagram detail sheet. For pole mounted service enclosures, the power indicator light shall be mounted as shown in the detail. For ground mounted enclosures, the power indicator light shall be mounted on the side of the enclosure most visible from the major roadway.
- c. Electric Utility Meter Housing and Riser. The electric meter housing and meter socket shall be supplied and installed by the contractor. The contractor is to coordinate the work to be performed and the materials required with the utility company to make the final connection at the power source. Electric utility required risers, weather/service head and any other materials necessary for connection shall also be included in the pay item. Materials shall be in accordance with the electric utility's requirements. For ground-mounted service, the electric utility meter housing shall be mounted to the enclosure. The meter shall be supplied by the utility company. Metered service shall not be used unless specified in the plans.
- d. Surge Protector. Overvoltage protection, with LED indicator, shall be provided for the 120 volt load circuit by the means MOV and thermal fusing technology. The response time shall be <5n seconds and operate within a range of -40C to +85C. The surge protector shall be UL 1449 Listed.
- e. Circuit Breakers. Circuit breakers shall be standard UL listed molded case, thermal-magnetic bolt-on type circuit breakers with trip free indicating handles. 120 volt circuit breakers shall have an interrupting rating of not less than 65,000 rms symmetrical amperes. Unless otherwise indicated, the main disconnect circuit breaker for the traffic signal controller shall be rated 60 amperes, 120 V and the auxiliary circuit breakers shall be rated 10 amperes, 120 V.

- f. Fuses, Fuseholders and Power Indicating Light. Fuses shall be small-dimensional cylindrical fuses of the dual element time-delay type. The fuses shall be rated for 600 V AC and shall have a UL listed interrupting rating of not less than 10,000 rms symmetrical amperes at rated voltage. The power indicating light shall be LED type with a green colored lens and shall be energized when electric utility power is present.
- g. Ground and Neutral Bus Bars. A single copper ground and neutral bus bar, mounted on the equipment panel shall be provided. Ground and neutral conductors shall be separated on the bus bar. Compression lugs, plus 2 spare lugs, shall be sized to accommodate the cables with the heads of the connector screws painted green for ground connections and white for neutral connections.
- h. Utility Services Connection. The Contractor shall notify the Utility Company marketing representative a minimum of 30 working days prior to the anticipated date of hook-up. This 30 day advance notification will begin only after the Utility Company marketing representative has received service charge payments from the Contractor. Prior to contacting the Utility Company marketing representative for service connection, the service installation controller cabinet and cable must be installed for inspection by the Utility Company.
- i. Ground Rod. Ground rods shall be copper-clad steel, a minimum of 10 feet (3.0m) in length, and 3/4 inch (20mm) in diameter. Ground rod resistance measurements to ground shall be 25 ohms or less. If necessary additional rods shall be installed to meet resistance requirements at no additional cost to the contract.

Installation.

- a. General. The Contractor shall confirm the orientation of the traffic service installation and its door side with the engineer, prior to installation. All conduit entrances into the service installation shall be sealed with a pliable waterproof material.
- b. Pole Mounted. Brackets designed for pole mounting shall be used. All mounting hardware shall be stainless steel. Mounting height shall be as noted on the plans or as directed by the Engineer.
- c. Ground Mounted. The service installation shall be mounted plumb and level on the foundation and fastened to the anchor bolts with hot-dipped galvanized or stainless steel nuts and washers. The space between the bottom of the enclosure and the top of the foundation shall be caulked at the base with silicone.

Basis of Payment.

The service installation shall be paid for at the contract unit price each for SERVICE INSTALLATION of the type specified which shall be payment in full for furnishing and installing the service installation complete. The CONCRETE FOUNDATION, TYPE A, which includes the ground rod, shall be paid for separately. SERVICE INSTALLATION, POLE

MOUNTED shall include the 3/4 inch (20mm) grounding conduit, ground rod, and pole mount assembly. Any charges by the utility companies shall be approved by the engineer and paid for as an addition to the contract according to Article 109.05 of the Standard Specifications.

GROUNDING OF TRAFFIC SIGNAL SYSTEMS

Effective: May 22, 2002

Revised: July 1, 2015

806.01TS

Revise Section 806 of the Standard Specifications to read:

General.

All traffic signal systems, equipment and appurtenances shall be properly grounded in strict conformance with the NEC. This work shall be in accordance with IDOT's District One Traffic Signal Design Details.

The grounding electrode system shall include a ground rod installed with each traffic signal controller concrete foundation and all mast arm and post concrete foundations. An additional ground rod will be required at locations where measured resistance exceeds 25 ohms. Ground rods are included in the applicable concrete foundation or service installation pay item and will not be paid for separately.

Testing shall be according to Article 801.13 (a) (4) and (5).

- (a) The grounded conductor (neutral conductor) shall be white color coded. This conductor shall be bonded to the equipment grounding conductor only at the Electric Service Installation. All power cables shall include one neutral conductor of the same size.
- (b) The equipment grounding conductor shall be green color coded. The following is in addition to Article 801.04 of the Standard Specifications.
 1. Equipment grounding conductors shall be bonded to the grounded conductor (neutral conductor) only at the Electric Service Installation. The equipment grounding conductor is paid for separately and shall be continuous. The Earth shall not be used as the equipment grounding conductor.
 2. Equipment grounding conductors shall be bonded, using a UL Listed grounding connector, to all traffic signal mast arm poles, traffic signal posts, pedestrian posts, pull boxes, handhole frames and covers, conduits, and other metallic enclosures throughout the traffic signal wiring system, except where noted herein. Bonding shall be made with a splice and pigtail connection, using a sized compression type copper sleeve, sealant tape, and heat-shrinkable cap. A UL listed electrical joint compound shall be applied to all conductors' terminations, connector threads and contact points. Conduit grounding bushings shall be installed at all conduit terminations including spare or empty conduits.
 3. All metallic and non-metallic raceways shall have a continuous equipment grounding conductor, except raceways containing only detector loop lead-in circuits, circuits under 50 volts and/or fiber optic cable will not be required to include an equipment grounding conductor.

4. Individual conductor splices in handholes shall be soldered and sealed with heat shrink.
When necessary to maintain effective equipment grounding, a full cable heat shrink shall be provided over individual conductor heat shrinks.
- (c) The grounding electrode conductor shall be similar to the equipment grounding conductor in color coding (green) and size. The grounding electrode conductor is used to connect the ground rod to the equipment grounding conductor and is bonded to ground rods via exothermic welding, UL listed pressure connectors, and UL listed clamps .

COILABLE NON-METALLIC CONDUIT

Effective: May 22, 2002

Revised: July 1, 2015

810.01TS

Description.

This work shall consist of furnishing and installing empty coilable non-metallic conduit (CNC).

General.

The CNC installation shall be in accordance with Sections 810 and 811 of the Standard Specifications except for the following:

Add the following to Article 810.03 of the Standard Specifications:

CNC meeting the requirements of NEC Article 353 shall be used for detector loop raceways to the handholes.

Add the following to Article 811.03 of the Standard Specifications:

On temporary traffic signal installations with detector loops, CNC meeting the requirements of NEC Article 353 shall be used for detector loop raceways from the saw-cut to 10 feet (3m) up the wood pole, unless otherwise shown on the plans

Basis of Payment.

All installations of CNC for loop detection shall be included in the contract and not paid for separately.

UNDERGROUND RACEWAYS

Effective: May 22, 2002

Revised: July 1, 2015

810.02TS

Revise Article 810.04 of the Standard Specifications to read:

“Installation. All underground conduits shall have a minimum depth of 30-inches (700 mm) below the finished grade.”

Add the following to Article 810.04 of the Standard Specifications:

“All metal conduit installed underground shall be Rigid Steel Conduit unless otherwise indicated on the plans.”

Add the following to Article 810.04 of the Standard Specifications:

“All raceways which extend outside of a structure or duct bank but are not terminated in a cabinet, junction box, pull box, handhole, post, pole, or pedestal shall extend a minimum of 300 mm (12”) or the length shown on the plans beyond the structure or duct bank. The end of this extension shall be capped and sealed with a cap designed for the conduit to be capped.

The ends of rigid metal conduit to be capped shall be threaded, the threads protected with full galvanizing, and capped with a threaded galvanized steel cap.

The ends of rigid nonmetallic conduit and coilable nonmetallic conduit shall be capped with a rigid PVC cap of not less than 3 mm (0.125”) thick. The cap shall be sealed to the conduit using a room-temperature-vulcanizing (RTV) sealant compatible with the material of both the cap and the conduit. A washer or similar metal ring shall be glued to the inside center of the cap with epoxy, and the pull cord shall be tied to this ring.”

HANDHOLES

Effective: January 01, 2002

Revised: July 1, 2018

814.01TS

Description.

Add the following to Section 814 of the Standard Specifications:

All conduits shall enter the handhole at a depth of 30 inches (762 mm) except for the conduits for detector loops when the handhole is less than 5 feet (1.52 m) from the detector loop. All conduit ends should be sealed with a waterproof sealant to prevent the entrance of contaminants into the handhole.

Steel cable hooks shall be coated with hot-dipped galvanization in accordance with AASHTO Specification M111. Hooks shall be a minimum of 1/2 inch (13 mm) diameter with two 90 degree bends and extend into the handhole at least 6 inches (152 mm). Hooks shall be placed a minimum of 12 inches (305 mm) below the lid or lower if additional space is required.

Precast round handholes shall not be used unless called out on the plans.

The cover of the handhole frame shall be labeled "Traffic Signals" with legible raised letters. Handhole covers for Red Light Running Cameras shall be labeled "RLRC".

Revise the third paragraph of Article 814.03 of the Standard Specifications to read:

"Handholes shall be constructed as shown on the plans and shall be cast-in-place, or precast concrete units. Heavy duty handholes shall be either cast-in-place or precast concrete units."

Add the following to Article 814.03 of the Standard Specifications:

"(c) Precast Concrete. Precast concrete handholes shall be fabricated according to Article 1042.17. Where a handhole is contiguous to a sidewalk, preformed joint filler of 1/2 inch (13 mm) thickness shall be placed between the handhole and the sidewalk."

Cast-In-Place Handholes.

All cast-in-place handholes shall be concrete, with inside dimensions of 21-1/2 inches (546 mm) minimum. Frames and lid openings shall match this dimension.

For grounding purposes the handhole frame shall have provisions for a 7/16 inch (11 mm) diameter stainless steel bolt cast into the frame. The covers shall have a stainless steel threaded stint extended from the eye hook assembly for the purpose of attaching the grounding conductor to the handhole cover.

The minimum wall thickness for heavy duty hand holes shall be 12 inches (305mm).

Precast Round Handholes.

All precast handholes shall be concrete, with inside dimensions of 30 inches (762mm) diameter. Frames and covers shall have a minimum opening of 26 inches (660mm) and no larger than the inside diameter of the handhole.

For grounding purposes the handhole frame shall have provisions for a 7/16 inch (11 mm) diameter stainless steel bolt cast into the frame. For the purpose of attaching the grounding conductor to the handhole cover, the covers shall either have a 7/16 inch (11 mm) diameter stainless steel bolt cast into the cover or a stainless steel threaded stint extended from an eye hook assembly. A hole may be drilled for the bolt if one cannot be cast into the frame or cover. The head of the bolt shall be flush or lower than the top surface of the cover.

The minimum wall thickness for precast heavy duty hand holes shall be 6 inches (152 mm).

Precast round handholes shall be only produced by an approved precast vendor.

Materials.

Add the following to Section 1042 of the Standard Specifications:

“1042.17 Precast Concrete Handholes. Precast concrete handholes shall be according to Articles 1042.03(a)(c)(d)(e).”

FIBER OPTIC TRACER CABLE

Effective: May 22, 2002

Revised: July 1, 2015

817.02TS

The cable shall meet the requirements of Section 817 of the Standard Specifications, except for the following:

Add the following to Article 817.03 of the Standard Specifications:

In order to trace the fiber optic cable after installation, the tracer cable shall be installed in the same conduit as the fiber optic cable in locations shown on the plans. The tracer cable shall be continuous, extended into the controller cabinet and terminated on a barrier type terminal strip mounted on the side wall of the controller cabinet. The barrier type terminal strip and tracer cable shall be clearly marked and identified. All tracer cable splices shall be kept to a minimum and shall incorporate maximum lengths of cable supplied by the manufacturer. The tracer cable will be allowed to be spliced at handholes only. The tracer cable splice shall use a Western Union Splice soldered with resin core flux and shall be soldered using a soldering iron. Blow torches or other devices which oxidize copper cable shall not be allowed for soldering operations. All exposed surfaces of the solder shall be smooth. The splice shall be covered with a black shrink tube meeting UL 224 guidelines, Type V and rated 600V, minimum length 4 inches (100 mm) and with a minimum 1 inch (25 mm) coverage over the XLP insulation, underwater grade.

Add the following to Article 817.05 of the Standard Specifications:

Basis of Payment.

The tracer cable shall be paid for separately as ELECTRIC CABLE IN CONDUIT, TRACER, NO. 14 1C per foot (meter), which price shall include all associated labor and material for installation.

RAILROAD, FULL-ACTUATED CONTROLLER AND CABINET

Effective: January 1, 2002

Revised: July 1, 2018

857.03TS

Description.

This work shall consist of furnishing and installing a traffic actuated solid state digital controller in the controller cabinet of the type specified, meeting the requirements of Section 857 of the Standard Specifications as modified herein and including conflict monitor or MMU, load switches and flasher relays, with interlock function to the railroad preemptor and all necessary connections for proper operation.

If the intersection is part of an existing system and/or when specified in the plans, this work shall consist of furnishing and installing a(n) " _____ " brand traffic actuated solid state controller.

Controller and cabinet shall be assembled only by an approved IDOT District One traffic signal equipment supplier. The equipment shall be tested and approved in the equipment supplier's District One's facility prior to field installation.

Materials.

Add the following to Article 857.02 of the Standard Specifications:

For installation as a stand-alone traffic signal, connected to a closed loop system or integrated into an advance traffic management system (ATMS), controllers shall be Econolite Cobalt or Eagle/Siemens M52 unless specified otherwise on the plans or elsewhere on these specifications. Only controllers supplied by one of the District One approved closed loop equipment supplier will be allowed. The controller shall be the most recent model and software version approved by IDOT for use with railroad intersections supplied by the equipment supplier at the time of the traffic signal TURN-ON unless specified otherwise on plans or this specification, and include a removable data key. Individual load switches shall be provided for each vehicle, pedestrian, and right turn over lap phase. The controller shall prevent phases from being omitted during program changes and after all preemption events and shall inhibit simultaneous display of circular yellow and yellow arrow indications.

For integration into an ATMS such as Centrac, Tactics, or TransSuite, the controller shall have the latest version of NTCIP software installed. For operation prior to integration into an ATMS, the controller shall maintain existing communications.

Controller shall comply with Article 1073.01 as amended herein.

Controller Cabinet and Peripheral Equipment shall comply with Article 1074.03 as amended in these Traffic Signal Special Provisions.

Add the following to Articles 1073.01 (c) (2) and 1074.03 (a) (5) (e) of the Standard Specifications:

Controllers and cabinets shall be new and NEMA TS2 Type 1 or NEMA TS2 Type 2 design.

Railroad interconnected controllers and cabinets shall be assembled only by an approved traffic signal equipment supplier. All railroad interconnected (including temporary railroad interconnect) controllers and cabinets shall be new, built, tested and approved by the controller equipment vendor, in the vendor's District One facility, prior to field installation. The vendor shall provide the technical equipment and assistance as required by the Engineer to fully test this equipment.

Add the following to Article 1074.03 of the Standard Specifications:

- (a) (6) Cabinets shall be designed for NEMA TS2 Type 1 or NEMA TS2 Type 2 operation. All cabinets shall be pre-wired for a minimum of eight (8) phases of vehicular, four (4) phases of pedestrian and four (4) phases of overlap operation.
- (b) (1) Revise “conflict monitor” to read “Malfunction Management Unit”
- (b) (5) Cabinets – Provide 1/8" (3.2 mm) thick unpainted aluminum alloy 5052-H32. The surface shall be smooth, free of marks and scratches. All external hardware shall be stainless steel.
- (b) (6) Controller Harness – Provide a TS2 Type 2 “A” wired harness in addition to the TS2 Type 1 harness.
- (b) (7) Surge Protection – Shall be a 120VAC Single phase Modular filter Plug-in type, supplied from an approved vendor.
- (b) (8) BIU – shall be secured by mechanical means.
- (b) (9) Transfer Relays – Solid state or mechanical flash relays are acceptable.
- (b) (10) Switch Guards – All switches shall be guarded.
- (b) (11) Heating – One (1) 200 watt, thermostatically-controlled, electric heater.
- (b) (12) Lighting – One (1) LED Panel shall be placed inside the cabinet top panel and one (1) LED Panel shall be placed on each side of the pull-out drawer/shelf assembly located beneath the controller support shelf. The LED Panels shall be controlled by a door switch. The LED Panels shall be provided from an approved vendor.
- (b) (13) The cabinet shall be equipped with a pull-out drawer/shelf assembly. A 1 ½ inch (38mm) deep drawer shall be provided in the cabinet, mounted directly beneath the controller support shelf. The drawer shall have a hinged top cover and shall be capable of accommodating one (1) complete set of cabinet prints and manuals. This drawer shall support 50 lbs. (23 kg) in weight when fully extended. The drawer shall open and close smoothly. Drawer dimensions shall make maximum use of available depth offered by the controller shelf and be a minimum of 18 inches (610mm) wide.
- (b) (14) Plan & Wiring Diagrams – 12” x 15” (3.05mm x 4.06mm) moisture sealed container attached to door.
- (b) (15) Detector Racks – Fully wired and labeled for four (4) channels of emergency vehicle pre-emption and sixteen channels (16) of vehicular operation.
- (b) (16) Field Wiring Labels – All field wiring shall be labeled.
- (b) (17) Field Wiring Termination – Approved channel lugs required.
- (b) (18) Power Panel – Provide a nonconductive shield.
- (b) (19) Circuit Breaker – The circuit breaker shall be sized for the proposed load but shall not be rated less than 30 amps.

- (b) (20) Police Door – Provide wiring and termination for plug in manual phase advance switch.
- (b) (21) Railroad Pre-Emption Test Switch – Shall be provided from an approved vendor

Installation.

Add the following to Article 857.03 of the Standard Specifications:

The Contractor shall arrange to install a standard voice-grade dial-up telephone line and all equipment to dial into the controller and have the controller dial out to the RAILROAD, FULL-ACTUATED CONTROLLER AND CABINET as called for on the traffic signal installation plans. If the traffic signal installation is part of a traffic signal system, a telephone line is usually not required, unless a telephone line is called for on the traffic signal plans. The Contractor shall follow the requirements for the telephone service installation as contained in the current District One Traffic Signal Special Provision for Master Controller.

Basis of Payment.

This work will be paid for at the contract unit price each for RAILROAD, FULL-ACTUATED CONTROLLER AND TYPE IV CABINET; RAILROAD, FULL-ACTUATED CONTROLLER AND TYPE V CABINET; RAILROAD, FULL-ACTUATED CONTROLLER AND TYPE SUPER P CABINET; RAILROAD, FULL-ACTUATED CONTROLLER AND TYPE SUPER R CABINET; RAILROAD, FULL-ACTUATED CONTROLLER AND TYPE IV CABINET, SPECIAL; RAILROAD, FULL-ACTUATED CONTROLLER AND TYPE V CABINET, SPECIAL; RAILROAD, FULL-ACTUATED CONTROLLER AND TYPE SUPER P CABINET (SPECIAL) or RAILROAD, FULL-ACTUATED CONTROLLER AND TYPE SUPER R CABINET (SPECIAL).

UNINTERRUPTABLE POWER SUPPLY, SPECIAL

Effective: January 1, 2013

Revised: May 19, 2016

862.01TS

This work shall be in accordance with section 862 of the Standard Specification except as modified herein

Add the following to Article 862.01 of the Standard Specifications:

The UPS shall have the power capacity to provide normal operation of a signalized intersection that utilizes all LED type signal head optics, for a minimum of 6 (six) hours.

Add the following to Article 862.02 of the Standard Specifications:

Materials shall be according to Article 1074.04 as modified in UNINTERRUPTABLE POWER SUPPLY, SPECIAL.

Add the following to Article 862.03 of the Standard Specifications:

The UPS shall additionally include, but not be limited to, a battery cabinet, where applicable. For Super-P (Type IV) and Super-R (Type V) cabinets, the battery cabinet is integrated to the traffic signal cabinet, and shall be included in the cost for the traffic signal cabinet of the size and type indicated on the plans.

The UPS shall provide reliable emergency power to the traffic signals in the event of a power failure or interruption.

Revise Article 862.04 of the Standard Specifications to read:

Installation.

When a UPS is installed at an existing traffic signal cabinet, the UPS cabinet shall partially rest on the lip of the existing controller cabinet foundation and be secured to the existing controller cabinet by means of at least four (4) stainless steel bolts. The UPS cabinet shall be completely enclosed with the bottom and back constructed of the same material as the cabinet.

When a UPS is installed at a new signal cabinet and foundation, it shall be mounted as shown on the plans.

At locations where UPS is installed and an Emergency Vehicle Priority System is in use, any existing incandescent confirmation beacons shall be replaced with LED lamps in accordance with the District One Emergency Vehicle Priority System specification at no additional cost to the contract. A concrete apron shall be provided and be in accordance with Articles 424 and 202 of the Standard Specifications. The concrete apron shall also, follow the District 1 Standard Traffic Signal Design Detail, Type D for Ground Mounted Controller Cabinet and UPS Battery Cabinet.

This item shall include any required modifications to an existing traffic signal controller as a result of the addition of the UPS including the addition of alarms.

Materials.

Revise Article 1074.04(a)(1) of the Standard Specifications to read:

The UPS shall be line interactive or double conversion and provide voltage regulation and power conditioning when utilizing utility power. The UPS shall be sized appropriately for the intersection(s) normal traffic signal operating load. The UPS must be able to maintain the intersection's normal operating load plus 20 percent (20%) of the intersection's normal operating load. When installed at a railroad-interconnected intersection the UPS must maintain the railroad pre-emption load, plus 20 percent (20%) of the railroad preemption-operating load. The total connected traffic signal load shall not exceed the published ratings for the UPS.

The UPS shall provide a minimum of 6 (six) hours of normal operation run-time for signalized intersections with LED type signal head optics at 77 °F (25 °C) (minimum 1000 W active output capacity, with 86 percent minimum inverter efficiency).

Revise the first paragraph of Article 1074.04(a)(3) of the Standard Specifications to read:

The UPS shall have a minimum of four (4) sets of normally open (NO) and normally closed (NC) single-pole double-throw (SPDT) relay contact closures, available on a panel mounted terminal block or locking circular connectors, rated at a minimum 120 V/1 A, and labeled so as to identify each contact according to the plans.

Revise Article 1074.04(a)(10) of the Standard Specifications to read:

The UPS shall be compatible with the District's approved traffic controller assemblies utilizing NEMA TS 1 or NEMA TS 2 controllers and cabinet components for full time operation.

Revise Article 1074.04(a)(17) of the Standard Specifications to read:

When the intersection is in battery backup mode, the UPS shall bypass all internal cabinet lights, ventilation fans, cabinet heaters, service receptacles, luminaires, any lighted street name signs, any automated enforcement equipment and any other devices directed by the Engineer.

Revise Article 1074.04(b)(2)b of the Standard Specifications to read:

Batteries, inverter/charger and power transfer relay shall be housed in a separate NEMA Type 3R cabinet. The cabinet shall be Aluminum alloy, 5052-H32, 0.125-inch thick and have a natural mill finish.

Revise Article 1074.04(b)(2)c of the Standard Specifications to read:

No more than three batteries shall be mounted on individual shelves for a cabinet housing six batteries and no more than four batteries per shelf for a cabinet housing eight batteries.

Revise Article 1074.04(b)(2)e of the Standard Specifications to read:

The battery cabinet housing shall have the following nominal outside dimensions: a width of 25 in. (785 mm), a depth of 16 in. (440 mm), and a height of 41 to 48 in. (1.1 to 1.3 m). Clearance between shelves shall be a minimum of 10 in. (250 mm).

End of paragraph 1074.04(b)(2)e

The door shall be equipped with a two position doorstop, one a 90° and one at 120°.

Revise Article 1074.04(b)(2)g of the Standard Specifications to read:

The door shall open to the entire cabinet, have a neoprene gasket, an Aluminum continuous piano hinge with stainless steel pin, and a three point locking system. The cabinet shall be provided with a main door lock which shall operate with a traffic industry conventional No. 2 key. Provisions for padlocking the door shall be provided.

Add the following to Article 1074.04(b)(2) of the Standard Specifications:

j. The battery cabinet shall have provisions for an external generator connection.

Add the following to Article 1074.04(c) of the Standard Specifications:

(8) The UPS shall include a tip or kill switch installed in the battery cabinet, which shall completely disconnect power from the UPS when the switch is manually activated.

(9) The UPS shall include standard RS-232 and internal Ethernet interface.

(10) The UPS shall incorporate a flanged electric generator inlet for charging the batteries and operating the UPS. The generator connector shall be male type, twist-lock, rated as 15A, 125VAC with a NEMA L5-15P configuration and weatherproof lift cover plate. Access to the generator inlet shall be from a secured weatherproof lift cover plate or behind a locked battery cabinet police panel.

(11) The bypass switch shall include an internal power transfer relay that allows removal of the battery back-up unit, while the traffic signal is connected to utility power, without impacting normal traffic signal operation.

Revise Article 1074.04(d)(3) of the Standard Specifications to read:

All batteries supplied in the UPS shall be either gel cell or AGM type, deep cycle, completely sealed, prismatic lead calcium based, silver alloy, valve regulated lead acid (VRLA) requiring no

maintenance. All batteries in a UPS installation shall be the same type; mixing of gel cell and AGM types within a UPS installation is not permitted.

Revise Article 1074.04(d)(4) of the Standard Specifications to read:

Batteries shall be certified by the manufacturer to operate over a temperature range of -13 to 160 °F (-25 to + 71 °C) for gel cell batteries and -40 to 140 °F (-40 to + 60 °C) for AGM type batteries.

Add the following to Article 1074.04(d) of the Standard Specifications:

(9) The UPS shall consist of an even number of batteries that are capable of maintaining normal operation of the signalized intersection for a minimum of 6 (six) hours. Calculations shall be provided showing the number of batteries of the type supplied that are needed to satisfy this requirement. A minimum of four batteries shall be provided.

(10) Battery Heater mats shall be provided, when gel cell type batteries are supplied.

Add the following to the Article 1074.04 of the Standard Specifications:

(e) Warranty. The warranty for an uninterruptable power supply (UPS) and batteries (full replacement) shall cover a minimum of 5 years from date the equipment is placed in operation.

(f) Installation. Bypass switch shall completely disconnect the traffic signal cabinet from the utility provider.

(g) The UPS shall be set-up to run the traffic signal continuously, without going to a red flashing condition, when switched to battery power unless otherwise directed by the Engineer. The Contractor shall confirm set-up with the Engineer. The continuous operation mode when switched to battery may require modification to unit connections and these modifications are included in the unit price for this item.

Revise Article 862.05 of the Standard Specifications to read:

Basis of Payment.

This work will be paid for at the contract unit price per each for UNINTERRUPTABLE POWER SUPPLY, SPECIAL or UNINTERRUPTABLE POWER SUPPLY AND CABINET, SPECIAL. Replacement of Emergency Vehicle Priority System confirmation beacons and any required modifications to the traffic signal controller shall be included in the cost of the UNINTERRUPTABLE POWER SUPPLY, SPECIAL or UNINTERRUPTABLE POWER SUPPLY AND CABINET, SPECIAL item. The concrete apron and earth excavation required shall be included in the cost of the UNINTERRUPTABLE POWER SUPPLY AND CABINET, SPECIAL item.

EMERGENCY VEHICLE PRIORITY SYSTEM LINE SENSOR CABLE, NO. 20 3/C

Effective: January 1, 2013

Revised: July 1, 2015

873.03TS

This work shall consist of furnishing and installing lead-in cable for light detectors installed at existing and/or proposed traffic signal installations as part of an emergency vehicle priority system. The work includes installation of the lead-in cables in existing and/or new conduit. The electric cable shall be shielded and have (3) stranded conductors, colored blue, orange, and yellow with a stranded tinned copper drain wire. The cable shall meet the requirements of the vendor of the Emergency Vehicle Priority System Equipment.

Basis of Payment.

This work will be paid for at the contract unit price per foot for EMERGENCY VEHICLE PRIORITY SYSTEM LINE SENSOR CABLE, NO. 20 3/C, which price shall be payment in full for furnishing, installing and making all electrical connections necessary for proper operations.

RAILROAD INTERCONNECT CABLE

Effective: May 22, 2002

Revised: July 1, 2015

873.04TS

The cable shall meet the requirements of Section 873 of the Standard Specifications, except for the following:

Add to Article 873.02 of the Standard Specifications:

- c) The railroad interconnect cable shall be three conductor stranded #14 copper cable in a clear polyester binder, shielded with #36 AWG tinned copper braid with 85% coverage, and insulated with .016" polyethylene (black, blue, red). The jacket shall be black 0.045 PVC or polyethylene.

Add the following to Article 873.06 of the Standard Specifications:

Basis of Payment.

This work shall be paid for at the contract unit price per foot (meter) for ELECTRIC CABLE IN CONDUIT, RAILROAD, NO. 14 3C, which price shall be payment in full for furnishing, installing, and making all electrical connections in the traffic signal controller cabinet. Connections in the railroad controller cabinet shall be performed by railroad personnel.

TRAFFIC SIGNAL POST

Effective: May 22, 2002

Revised: July 01, 2015

875.01TS

Add the following to Article 1077.01 (c) of the Standard Specifications:

Washers for post bases shall be the same size or larger than the nut.

Revise the first sentence of Article 1077.01 (d) of the Standard Specifications to read:

All posts and bases shall be steel and hot dipped galvanized according to AASHTO M 111. If the Department approves painting, powder coating by the manufacturer will be required over the galvanization in accordance with 851.01TS TRAFFIC SIGNAL PAINTING Special Provisions.

**LIGHT EMITTING DIODE (LED) SIGNAL HEAD AND OPTICALLY PROGRAMMED
LED SIGNAL HEAD**

Effective: May 22, 2002

Revised: July 1, 2015

880.01TS

Materials.

Add the following to Section 1078 of the Standard Specifications:

1. LED modules proposed for use and not previously approved by IDOT District One will require independent testing for compliance to current VTCSH-ITE standards for the product and be Intertek ETL Verified. This would include modules from new vendors and new models from IDOT District One approved vendors.
2. The proposed independent testing facility shall be approved by IDOT District One. Independent testing must include a minimum of two (2) randomly selected modules of each type of module (i.e. ball, arrow, pedestrian, etc.) used in the District and include as a minimum Luminous Intensity and Chromaticity tests. However, complete module performance verification testing may be required by the Engineer to assure the accuracy of the vendor's published data and previous test results. An IDOT representative will select sample modules from the local warehouse and mark the modules for testing. Independent test results shall meet current ITE standards and vendor's published data. Any module failures shall require retesting of the module type. All costs associated with the selection of sample modules, testing, reporting, and retesting, if applicable, shall be the responsibility of the LED module vendor and not be a cost to this contract.
3. All signal heads shall provide 12" (300 mm) displays with glossy yellow or black polycarbonate housings. All head housings shall be the same color (yellow or black) at the intersection. For new signalized intersections and existing signalized intersections where all signals heads are being replaced, the proposed head housings shall be black. Where only selected heads are being replaced, the proposed head housing color (yellow or black) shall match existing head housings. Connecting hardware and mounting brackets shall be polycarbonate (black). A corrosion resistant anti-seize lubricant shall be applied to all metallic mounting bracket joints, and shall be visible to the inspector at the signal turn-on. Post top mounting collars are required on all posts, and shall be constructed of the same material as the brackets.
4. The LED signal modules shall be replaced or repaired if an LED signal module fails to function as intended due to workmanship or material defects within the first 7 years from the date of traffic signal TURN-ON. LED signal modules which exhibit luminous intensities less than the minimum values specified in Table 1 of the ITE Vehicle Traffic Control Signal Heads: Light Emitting Diode (LED) Circular Signal Supplement (June 27, 2005) [VTCSH], or applicable successor ITE specifications, or show signs of entrance of moisture or contaminants within the first 7 years of the date of traffic signal TURN-ON shall be replaced or repaired. The vendor's written warranty for the LED signal modules

shall be dated, signed by a vendor's representative and included in the product submittal to the State.

(a) Physical and Mechanical Requirements

1. Modules can be manufactured under this specification for the following faces:
 - a. 12 inch (300 mm) circular, multi-section
 - b. 12 inch (300 mm) arrow, multi-section
2. The maximum weight of a module shall be 4 lbs. (1.8 kg).
3. Each module shall be a sealed unit to include all parts necessary for operation (a printed circuit board, power supply, a lens and gasket, etc.), and shall be weather proof after installation and connection.
5. The lens of the module shall be tinted with a wavelength-matched color to reduce sun phantom effect and enhance on/off contrast. The tinting shall be uniform across the lens face. Polymeric lens shall provide a surface coating or chemical surface treatment applied to provide abrasion resistance. The lens of the module shall be integral to the unit, convex with a smooth outer surface and made of plastic. The lens shall have a textured surface to reduce glare.
6. The use of tinting or other materials to enhance ON/OFF contrasts shall not affect chromaticity and shall be uniform across the face of the lens.
7. Each module shall have a symbol of the type of module (i.e. circle, arrow, etc.) in the color of the module. The symbol shall be 1 inch (25.4 mm) in diameter. Additionally, the color shall be written out in 1/2 inch (12.7mm) letters next to the symbol.

(b) Photometric Requirements

4. The LEDs utilized in the modules shall be AlInGaP technology for red and InGaN for green and amber indications, and shall be the ultra bright type rated for 100,000 hours of continuous operation from -40 °C to +74 °C.

(c) Electrical

1. Maximum power consumption for LED modules is per Table 2.
2. Operating voltage of the modules shall be 120 VAC. All parameters shall be measured at this voltage.
3. The modules shall be operationally compatible with currently used controller assemblies (solid state load switches, flashers, and conflict monitors).

4. When a current of 20 mA AC (or less) is applied to the unit, the voltage read across the two leads shall be 15 VAC or less.
5. The LED modules shall provide constant light output under power. Modules with dimming capabilities shall have the option disabled or set on a non-dimming operation.
6. LED arrows shall be wired such that a catastrophic loss or the failure of one or more LED will not result in the loss of the entire module.

(d) Retrofit Traffic Signal Module

1. The following specification requirements apply to the Retrofit module only. All general specifications apply unless specifically superseded in this section.
2. Retrofit modules can be manufactured under this specification for the following faces:
 - a. 12 inch (300 mm) circular, multi-section
 - b. 12 inch (300 mm) arrow, multi-section
3. Each Retrofit module shall be designed to be installed in the doorframe of a standard traffic signal housing. The Retrofit module shall be sealed in the doorframe with a one-piece EPDM (ethylene propylene rubber) gasket.
4. The maximum weight of a Retrofit module shall be 4 lbs. (1.8 kg).
5. Each Retrofit module shall be a sealed unit to include all parts necessary for operation (a printed circuit board, power supply, a lens and gasket, etc.), and shall be weather proof after installation and connection.
6. Electrical conductors for modules, including Retrofit modules, shall be 39.4 inches (1m) in length, with quick disconnect terminals attached.
7. The lens of the Retrofit module shall be integral to the unit, shall be convex with a smooth outer surface and made of plastic or of glass.

(e) The following specification requirements apply to the 12 inch (300 mm) arrow module only. All general specifications apply unless specifically superseded in this section.

1. The arrow module shall meet specifications stated in Section 9.01 of the Equipment and Material Standards of the Institute of Transportation Engineers (November 1998) [ITE Standards], Chapter 2 (Vehicle Traffic Control Signal Heads) or applicable successor ITE specifications for arrow indications.
2. The LEDs arrow indication shall be a solid display with a minimum of three (3) outlining rows of LEDs and at least one (1) fill row of LEDs.

(f) The following specification requirement applies to the 12 inch (300 mm) programmed visibility (PV) module only. All general specifications apply unless specifically superseded in this section.

1. The LED module shall be a module designed and constructed to be installed in a programmed visibility (PV) signal housing without modification to the housing.

Basis of Payment.

Add the following to the first paragraph of Article 880.04 of the Standard Specifications:

The price shall include furnishing the equipment described above, all mounting hardware and installing them in satisfactory operating condition.

Revise the second paragraph of Article 880.04 of the Standard Specifications to read:

If the work consists of retrofitting an existing polycarbonate traffic signal head with light emitting diodes (LEDs), it will be paid for as a SIGNAL HEAD, LED, RETROFIT, of the type specified, and of the particular kind of material, when specified. Price shall be payment in full for removal of the existing module, furnishing the equipment described above including LED modules, all mounting hardware, and installing them in satisfactory operating condition. The type specified will indicate the number of signal faces, the number of signal sections in each signal face and the method of mounting.

FLASHING BEACON INSTALLATION, RELOCATION AND REMOVAL

Effective: January 1, 2007

Revised: July 1, 2015

880.02TS

This work shall consist of furnishing and installing a new flashing beacon installation, solar powered flashing beacon installation, relocation of existing flashing beacon, and/or the removal of the existing flashing beacon installation as shown on the plans and as described herein. The energy charges for the operation of the flashing beacon installation shall be paid for by the Department unless otherwise directed by the Engineer.

The installation, relocation and removal of flashing beacon installation shall be according to the applicable portions of Sections 800 and 1000 of the Standard Specifications for Road and Bridge Construction and District 1 Flashing Beacon Installation Details except as revised herein. LED signal heads shall be as modified in 880.01TS LED SIGNAL HEAD AND OPTICALLY PROGRAMMED LED SIGNAL HEAD Special Provision.

- (a) Flashing Beacon Installation. This item shall consist of installing a post mounted 12 inch (300 mm) L.E.D. single section red or yellow flashing beacon on a new or existing post as shown on the plans or as directed by the Engineer. This item shall include furnishing and installing a flasher controller in an aluminum cabinet, or integrated within the signal head, 12 inch (300 mm) L.E.D. red or yellow signal section with a dimmer if required by the Engineer, and all other hardware necessary to complete the installation.
- (b) Solar Powered Flashing Beacon Installation. This item shall consist of installation of a solar powered flashing beacon, post mounted as shown on the plans or as directed by the Engineer. This item shall consist of furnishing and installing a 12 inch (300 mm) single red or yellow flashing module on a new or existing post as shown on the plans or as directed by the Engineer. This item shall include furnishing and installing a flasher controller that is integrated within the signal head, with discrete solar panels, LED module, battery, electronics, compact housing and be capable of operating 24 hours, 7 days a week. The flasher unit shall be installed on standard wood or metal posts. The flash pattern shall be MUTCD compliant and have alternate flash patterns available. The battery shall have a life span of a minimum of 5 years and be field replaceable. The battery and electronics may be located inside the solar panel housing or signal head. The sections of the flasher unit shall be secured with tamper resistant stainless steel hardware and unless otherwise noted, the housing shall be black in color.
- (c) Relocate Existing Flashing Beacon. Relocation of an existing flashing beacon installation, as shown on the plans or as directed by the Engineer, shall meet the above requirements. This work shall include the complete relocation of the existing flashing beacon installation, the backfilling of the holes created by the removal of the poles, restoration of the surface to match the adjoining area.
- (d) Remove Existing Flashing Beacon Installation Complete. Removal of an existing flashing beacon installation shall be as shown on the plans or as directed by the Engineer and shall be according to applicable portions of Section 895 of the Standard Specifications. This work shall include a complete removal of an existing flashing beacon installation, backfilling of the holes created by the removal of the poles and restoration of the surface to match the adjoining area. The flashing beacon installation will be removed only after the permanent signal installation is accepted for maintenance, or as directed by the Engineer.

Basis of Payment.

This work shall be paid for at the contract unit price each for FLASHING BEACON INSTALLATION; SOLAR POWERED FLASHING BEACON INSTALLATION; RELOCATE EXISTING FLASHING BEACON or REMOVE EXISTING FLASHING BEACON INSTALLATION COMPLETE. The price shall be payment in full for all labor and material necessary to complete the work described above.

LIGHT EMITTING DIODE (LED) PEDESTRIAN SIGNAL HEAD

Effective: May 22, 2002

Revised: July 1, 2015

881.01TS

Add the following to the third paragraph of Article 881.03 of the Standard Specifications:

No mixing of different types of pedestrian traffic signals or displays will be permitted.

Add the following to Article 881.03 of the Standard Specifications:

(a) Pedestrian Countdown Signal Heads.

- (1) Pedestrian Countdown Signal Heads shall not be installed at signalized intersections where traffic signals and railroad warning devices are interconnected.
- (2) Pedestrian Countdown Signal Heads shall be 16 inch (406mm) x 18 inch (457mm), for single units with glossy yellow or black polycarbonate housings. All pedestrian head housings shall be the same color (yellow or black) at the intersection. For new signalized intersections and existing signalized intersections where all pedestrian heads are being replaced, the proposed head housings shall be black. Where only selected heads are being replaced, the proposed head housing color (yellow or black) shall match existing head housings. Connecting hardware and mounting brackets shall be polycarbonate (black). A corrosion resistant anti-seize lubricant shall be applied to all metallic mounting bracket joints, and shall be visible to the inspector at the signal turn-on.
- (3) Each pedestrian signal LED module shall be fully MUTCD compliant and shall consist of double overlay message combining full LED symbols of an Upraised Hand and a Walking Person. "Egg Crate" type sun shields are not permitted. Numerals shall measure 9 inches (229mm) in height and easily identified from a distance of 120 feet (36.6m).

Materials.

Add the following to Article 1078.02 of the Standard Specifications:

General.

1. The module shall operate in one mode: Clearance Cycle Countdown Mode Only. The countdown module shall display actual controller programmed clearance cycle and shall start counting when the flashing clearance signal turns on and shall countdown to "0" and turn off when the steady Upraised Hand (symbolizing Don't Walk) signal turns on. Module shall not have user accessible switches or controls for modification of cycle.
2. At power on, the module shall enter a single automatic learning cycle. During the automatic learning cycle, the countdown display shall remain dark.

3. The module shall re-program itself if it detects any increase or decrease of Pedestrian Timing. The counting unit will go blank once a change is detected and then take one complete pedestrian cycle (with no counter during this cycle) to adjust its buffer timer.
4. If the controller preempts during the Walking Person (symbolizing Walk), the countdown will follow the controller's directions and will adjust from Walking Person to flashing Upraised Hand. It will start to count down during the flashing Upraised Hand.
5. If the controller preempts during the flashing Upraised Hand, the countdown will continue to count down without interruption.
6. The next cycle, following the preemption event, shall use the correct, initially programmed values.
7. If the controller output displays Upraised Hand steady condition and the unit has not arrived to zero or if both the Upraised Hand and Walking Person are dark for some reason, the unit suspends any timing and the digits will go dark.
8. The digits will go dark for one pedestrian cycle after loss of power of more than 1.5 seconds.
9. The countdown numerals shall be two (2) "7 segment" digits forming the time display utilizing two rows of LEDs.
10. The LED module shall meet the requirements of the Institute of Transportation Engineers (ITE) LED purchase specification, "Pedestrian Traffic Control Signal Indications - Part 2: LED Pedestrian Traffic Signal Modules," or applicable successor ITE specifications, except as modified herein.
11. The LED modules shall provide constant light output under power. Modules with dimming capabilities shall have the option disabled or set on a non-dimming operation.
12. In the event of a power outage, light output from the LED modules shall cease instantaneously.
13. The LEDs utilized in the modules shall be AlInGaP technology for Portland Orange (Countdown Numerals and Upraised Hand) and GaN technology for Lunar White (Walking Person) indications.
14. The individual LEDs shall be wired such that a catastrophic loss or the failure of one or more LED will not result in the loss of the entire module.

Basis of Payment.

Add the following to the first paragraph of Article 881.04 of the Standard Specifications:

The price shall include furnishing the equipment described above, all mounting hardware and installing them in satisfactory operating condition.

Add the following to Article 881.04 of the Standard Specifications:

If the work consists of retrofitting an existing polycarbonate pedestrian signal head and pedestrian countdown signal head with light emitting diodes (LEDs), it will be paid for as a PEDESTRIAN SIGNAL HEAD, LED, RETROFIT, of the type specified, and of the particular kind of material, when specified. Price shall be payment in full for furnishing the equipment described above including LED modules, all mounting hardware, and installing them in satisfactory operating condition.

TRAFFIC SIGNAL BACKPLATE

Effective: May 22, 2002

Revised: July 1, 2015

882.01TS

Delete 1st sentence of Article 1078.03 of the Standard Specifications and add “All backplates shall be louvered, formed ABS plastic”.

Add the following to the third paragraph of Article 1078.03 of the Standard Specifications. The retroreflective backplate shall not contain louvers.

Delete second sentence of the fourth paragraph of Article 1078.03 the Standard Specifications.

Add the following to the fourth paragraph of Article 1078.03 of the Standard Specifications:

When retro reflective sheeting is specified, it shall be Type ZZ sheeting according to Article 1091.03 and applied in preferred orientation for the maximum angularity according to the vendor’s recommendations. The retroreflective sheeting shall be installed under a controlled environment at the vendor/equipment supplier before shipment to the contractor. The formed plastic backplate shall be prepared and cleaned, following recommendations of the retroreflective sheeting manufacturer.

DETECTOR LOOP

Effective: May 22, 2002

Revised: July 1, 2018

886.01TS

Procedure.

A minimum of seven (7) working days prior to the Contractor cutting loops, the Contractor shall mark the proposed loop locations and contact the Area Traffic Signal Maintenance and Operations Engineer (847) 705-4424 to inspect and approve the layout. When preformed detector loops are installed, the Contractor shall have them inspected and approved prior to the pouring of the Portland cement concrete surface, using the same notification process as above.

Installation.

Revise Article 886.04 of the Standard Specifications to read:

Loop detectors shall be installed according to the requirements of the "District One Standard Traffic Signal Design Details." Saw-cuts (homeruns on preformed detector loops) from the loop to the edge of pavement shall be made perpendicular to the edge of pavement when possible in order to minimize the length of the saw-cut (homerun on preformed detector loops) unless directed otherwise by the Engineer or as shown on the plan.

The detector loop cable insulation shall be labeled with the cable specifications.

Each loop detector lead-in wire shall be labeled in the handhole using a water proof tag, from an approved vendor, secured to each wire with nylon ties.

Resistance to ground shall be a minimum of 100 mega-ohms under any conditions of weather or moisture. Inductance shall be more than 50 and less than 700 microhenries. Quality readings shall be more than 5.

- (a) Type I. All loops installed in new asphalt pavement shall be installed in the binder course and not in the surface course. The edge of pavement, curb and handhole shall be cut with a 1/4 inch (6.3 mm) deep x 4 inches (100 mm) saw cut to mark location of each loop cable.
- (b) Loop sealant shall be two-component thixotropic chemically cured polyurethane from an approved vendor. The sealant shall be installed 1/8 inch (3 mm) below the pavement surface. If installed above the surface the excess shall be removed immediately.
- (c) Preformed. This work shall consist of furnishing and installing a rubberized or cross linked polyethylene heat resistant preformed traffic signal loop in accordance with the Standard Specifications, except for the following:
- (d) Preformed detector loops shall be installed in the sub-base under the Portland cement concrete pavement. Loop lead-ins shall be extended to a temporary protective enclosure near the proposed handhole location. The protective enclosure shall provide sufficient protection from other construction activities and may be buried for additional protection.

- (e) Handholes shall be placed next to the shoulder or back of curb when preformed detector loops enter the handhole. CNC, included in this pay item, shall be used to protect the preformed lead-ins from back of curb to the handhole.
- (f) Preformed detector loops shall be factory assembled with ends capped and sealed against moisture and other contaminants. The loop configurations and homerun lengths shall be assembled for the specific application. The loop and homerun shall be constructed using 5/8 inch (16 mm) outside diameter (minimum), 3/8 inch (9.5 mm) inside diameter (minimum) Class A oil resistant synthetic cord reinforced hydraulic hose with 250 psi (1,720 kPa) internal pressure rating or a similarly sized XLPE cable jacket. Hose for the loop and homerun assembly shall be one continuous piece. No joints or splices shall be allowed in the hose except where necessary to connect homeruns to the loops. This will provide maximum wire protection and loop system strength. Hose tee connections shall be heavy duty high temperature synthetic rubber. The tee shall be of proper size to attach directly to the hose, minimizing glue joints. The tee shall have the same flexible properties as the hose to insure that the whole assembly can conform to pavement movement and shifting without cracking or breaking. For XLPE jacketed preformed loops, all splice connections shall be soldered, sealed, and tested before being sealed in a high impact glass impregnated plastic splice enclosure. The wire used shall be #16 THWN stranded copper. The number of turns in the loop shall be application specific. Homerun wire pairs shall be twisted a minimum of eight turns per foot. No wire splices will be allowed in the preformed loop assembly. The loop and homeruns shall be filled and sealed with a flexible sealant to insure complete moisture blockage and further protect the wire. The preformed loops shall be constructed to allow a minimum of 6.5 feet of extra cable in the handhole.

Method of Measurement.

Add the following to Article 886.05 of the Standard Specifications:

Preformed detector loops will be measured along the detector loop embedded in the pavement, rather than the actual length of the wire. Detector loop measurements shall include the saw cut and the length of the detector loop wire to the edge of pavement. The detector loop wire, including all necessary connections for proper operations, from the edge of pavement to the handhole, shall be included in the price of the detector loop. CNC, trench and backfill, and drilling of pavement or handholes shall be included in detector loop quantities.

Basis of Payment.

This work shall be paid for at the contract unit price per foot (meter) for DETECTOR LOOP, TYPE I or PREFORMED DETECTOR LOOP as specified in the plans, which price shall be payment in full for furnishing and installing the detector loop and all related connections for proper operation.

RADAR VEHICLE DETECTION SYSTEM

Effective: July 01, 2015

Revised: May 9, 2017

886.03TS

Description.

This work shall consist of furnishing and installing a radar vehicle detection system as specified and/or as shown on the plan. This pay item shall include all necessary work and equipment required to have a fully operational system including but not limited to the detector unit/s, the interface unit and all the necessary hardware, cable and accessories required to complete the installation in accordance with the manufacturer's specifications.

The radar vehicle detection system shall work under all weather conditions, including rain, freezing rain, snow, wind, dust, fog, and changes in temperature and light. It shall work in an ambient temperature range of -34 to 74 degrees Celsius. It shall have a max power output of 75 watts or less.

The radar vehicle detection system shall be compatible with the District's approved traffic controller assemblies utilizing NEMA TS 1 or NEMA TS 2 controllers and cabinet components for full time operation. The radar vehicle detection system shall provide a minimum of one interface unit that has Ethernet connectivity, surge protection and shall be capable of supporting a minimum of 2 detector units.

The stop bar radar vehicle detection system shall have true presence capabilities in which it can detect stopped, slow moving or turning vehicles similar to the Departments in-pavement detection. This is especially important at side streets where driveways are near the intersection. The radar shall be able to drop the call if the vehicle leaves the detection zone. A manufacture statement confirming proper operation is required along each catalog cut submittal. The Department will not allow substitutes for other types of detection.

The far back radar detection shall have a detection range of 400 feet or better.

A representative from the supplier of the radar vehicle detection system shall supervise the installation and testing of the radar vehicle detection system and shall be present at the traffic signal turn-on inspection. Once the radar vehicle detection system is configured, it shall not need reconfiguration to maintain performance, unless the roadway configuration or the application requirements change.

The mounting location/s of the detector unit/s shall be per the manufacturer's recommendations. If an extension mounting assembly is needed, it shall be included in this item. All holes drilled into signal poles, mast arms, or posts shall require rubber grommets to prevent chafing of wires.

The radar vehicle detection system shall be warrantied, free from material and workmanship defects for a period of two years from final inspection.

Basis of Payment.

This work shall be paid for at the contract unit price each for RADAR VEHICLE DETECTION SYSTEM, SINGLE APPROACH, STOP BAR; RADAR VEHICLE DETECTION SYSTEM, SINGLE APPROACH, FAR BACK; RADAR VEHICLE DETECTION SYSTEM, SINGLE APPROACH, STOP BAR AND FAR BACK, the price of which shall include the cost for all of the work and material described herein and includes furnishing, installing, delivery, handling, testing, set-up and all appurtenances and mounting hardware necessary for a fully operational radar vehicle detection system.

EMERGENCY VEHICLE PRIORITY SYSTEM

Effective: May 22, 2002

Revised: July 1, 2015

887.01TS

Revise Section 887 of the Standard Specifications to read:

It shall be the Contractor's responsibility to contact the municipality or fire district to verify the brand of emergency vehicle pre-emption equipment to be installed prior to the contract bidding. The equipment must be completely compatible with all components of the equipment currently in use by the Agency.

All new installations shall be equipped with Confirmation Beacons as shown on the "District One Standard Traffic Signal Design Details." The Confirmation Beacon shall consist of a 6 watt Par 38 LED flood lamp with a 30 degree light spread, or a 7 watt Par 30 LED flood lamp with a 15 degree or greater spread, maximum 7 watt energy consumption at 120V, and a 2,000 hour warranty for each direction of pre-emption. The lamp shall have an adjustable mount with a weatherproof enclosure for cable splicing. All hardware shall be cast aluminum or stainless steel. Holes drilled into signal poles, mast arms, or posts shall require rubber grommets. In order to maintain uniformity between communities, the confirmation beacons shall indicate when the control equipment receives the pre-emption signal. The pre-emption movement shall be signalized by a flashing indication at the rate specified by Section 4L.01 of the "Manual on Uniform Traffic Control Devices," and other applicable sections of future editions. The stopped pre-empted movements shall be signalized by a continuous indication.

All light operated systems shall include security and transit preemption software and operate at a uniform rate of 14.035 Hz \pm 0.002, or as otherwise required by the Engineer, and provide compatible operation with other light systems currently being operated in the District.

This item shall include any required modifications to an existing traffic signal controller as a result of the addition of the EMERGENCY VEHICLE PRIORITY SYSTEM.

Basis of Payment.

The work shall be paid for at the contract unit price each for furnishing and installing LIGHT DETECTOR and LIGHT DETECTOR AMPLIFIER. Furnishing and installing the confirmation beacon shall be included in the cost of the Light Detector. Any required modifications to the traffic signal controller shall be included in the cost of the LIGHT DETECTOR AMPLIFIER. The preemption detector amplifier shall be paid for on a basis of (1) one each per intersection controller and shall provide operation for all movements required in the pre-emption phase sequence.

PEDESTRIAN PUSH-BUTTON

Effective: May 22, 2002

Revised: July 1, 2015

888.01TS

Description.

Revise Article 888.01 of the Standard Specifications to read:

This work shall consist of furnishing and installing a latching (single call) or non-latching (dual call) pedestrian push-button and a regulatory pedestrian instruction sign according to MUTCD, sign series R10-3e 9" x 15" sign with arrow(s) for a count-down pedestrian signal. The pedestrian station sign size without count-down pedestrian signals shall accommodate a MUTCD sign series R10-3b or R10-3d 9" x 12" sign with arrow(s).

Installation.

Add the following to Article 888.03 of the Standard Specifications:

A mounting bracket and/or extension shall be used to assure proper orientation when two pedestrian push buttons are required for one post. The price of the bracket and/or extension shall be included in the cost of the pedestrian push button. The contractor is not allowed to install a push-button assembly with the sign below the push-button in order to meet mounting requirements.

Materials.

Revise Article 1074.02(a) of the Standard Specifications to read:

The pedestrian push-button housing shall be constructed of aluminum alloy according to ASTM B 308 6061-T6 and powder coated yellow, unless otherwise noted on the plans. The housing shall be furnished with suitable mounting hardware.

Revise Article 1074.02(e) of the Standard Specifications to read:

Stations shall be designed to be mounted to a post, mast arm pole or wood pole. The station shall be aluminum and shall accept a 3 inch (75mm) round push-button assembly and a regulatory pedestrian instruction sign according to MUTCD, sign series R10-3e 9" x 15" sign with arrow(s) for a count-down pedestrian signal. The pedestrian station size without count-down pedestrian signals shall accommodate a MUTCD sign series R10-3b or R10-3d 9" x 12" sign with arrow(s).

Add the following to Article 1074.02 of the Standard Specifications:

- (f) Location. Pedestrian push-buttons and stations shall be mounted to a post, mast arm pole or wood pole as shown on the plans and shall be fully ADA accessible from a paved or concrete surface. See the District's Detail sheets for orientation and mounting details.

Basis of Payment.

Revise Article 888.04 of the Standard Specifications to read:

This work will be paid for at the contract unit price per each for PEDESTRIAN PUSH-BUTTON or PEDESTRIAN PUSH-BUTTON, NON-LATCHING.

TEMPORARY TRAFFIC SIGNAL INSTALLATION

Effective: May 22, 2002

Revised: January 1, 2017

890.01TS

Revise Section 890 of the Standard Specifications to read:

Description.

This work shall consist of furnishing, installing, maintaining, and removing a temporary traffic signal installation as shown on the plans, including but not limited to temporary signal heads, emergency vehicle priority systems, interconnect, vehicle detectors, uninterruptable power supply, and signing. Temporary traffic signal controllers and cabinets interconnected to railroad traffic control devices shall be new. When temporary traffic signals will be operating within a county or local agency Traffic Management System, the equipment must be NTCIP compliant and compatible with the current operating requirements of the Traffic Management System.

General.

Only an approved controller equipment supplier will be allowed to assemble temporary traffic signal and railroad traffic signal cabinet. Traffic signal inspection and TURN-ON shall be according to 800.01TS TRAFFIC SIGNAL GENERAL REQUIREMENTS special provision.

Construction Requirements.

(a) Controllers.

1. Only controllers supplied by one of the District approved closed loop equipment supplier will be approved for use at temporary signal locations. All controllers used for temporary traffic signals shall be fully actuated NEMA microprocessor based with RS232 data entry ports compatible with existing monitoring software approved by IDOT District 1, installed in NEMA TS2 cabinets with 8 phase back panels, capable of supplying 255 seconds of cycle length and individual phase length settings up to 99 seconds. On projects with one lane open and two way traffic flow, such as bridge deck repairs, the temporary signal controller shall be capable of providing an adjustable all red clearance setting of up to 30 seconds in length. All controllers used for temporary traffic signals shall meet or exceed the requirements of Section 857 of the Standard Specifications with regards to internal time base coordination and preemption. All railroad interconnected temporary controllers and cabinets shall be new and shall satisfy the requirements of Article 857.02 of the Standard Specifications and as modified herein.
2. Only control equipment, including controller cabinet and peripheral equipment, supplied by one of the District approved closed loop equipment suppliers will be approved for use at temporary traffic signal locations. All control equipment for the temporary traffic signal(s) shall be furnished by the Contractor unless otherwise stated in the plans. On projects with multiple temporary traffic signal installations, all controllers shall be the same manufacturer brand and model

number with the latest version software installed at the time of the signal TURN-ON.

- (b) Cabinets. All temporary traffic signal cabinets shall have a closed bottom made of aluminum alloy. The bottom shall be sealed along the entire perimeter of the cabinet base to ensure a water, dust and insect-proof seal. The bottom shall provide a minimum of two (2) 4 inch (100 mm) diameter holes to run the electric cables through. The 4 inch (100 mm) diameter holes shall have a bushing installed to protect the electric cables and shall be sealed after the electric cables are installed.
- (c) Grounding. Grounding shall be provided for the temporary traffic signal cabinet meeting or exceeding the applicable portions of the National Electrical Code, Section 806 of the Standard Specifications and shall meet the requirements of the 806.01TS GROUNDING OF TRAFFIC SIGNAL SYSTEMS special provision.
- (d) Traffic Signal Heads. All traffic signal sections shall be 12 inches (300 mm). Pedestrian signal sections shall be 16 inch (406mm) x 18 inch (457mm). Traffic signal sections shall be LED with expandable view, unless otherwise approved by the Engineer. Pedestrian signal heads shall be Light Emitting Diode (LED) Pedestrian Countdown Signal Heads except when a temporary traffic signal is installed at an intersection interconnected with a railroad grade crossing. When a temporary traffic signal is installed at an intersection interconnected with a railroad grade crossing, Light Emitting Diode (LED) Pedestrian Signal Heads shall be furnished. The temporary traffic signal heads shall be placed as indicated on the temporary traffic signal plan or as directed by the Engineer. If no traffic staging is in place or will not be staged on the day of the turn on, the temporary traffic signal shall have the signal head displays, signal head placements and controller phasing match the existing traffic signal or shall be as directed by the engineer. The Contractor shall furnish enough extra cable length to relocate heads to any position on the span wire or at locations illustrated on the plans for construction staging. The temporary traffic signal shall remain in operation during all signal head relocations. Each temporary traffic signal head shall have its own cable from the controller cabinet to the signal head.
- (e) Interconnect.
 - 1. Temporary traffic signal interconnect shall be provided using fiber optic cable or wireless interconnect technology as specified in the plans. The Contractor may request, in writing, to substitute the fiber optic temporary interconnect indicated in the contract documents with a wireless interconnect. The Contractor must provide assurances that the radio device will operate properly at all times and during all construction staging. If approved for use by the Engineer, the Contractor shall submit marked-up traffic signal plans indicating locations of radios and antennas and installation details. If wireless interconnect is used, and in the opinion of the engineer, it is not viable, or if it fails during testing or operations, the Contractor shall be responsible for installing all necessary poles,

fiber optic cable, and other infrastructure for providing temporary fiber optic interconnect at no cost to the contract.

2. The existing system interconnect and phone lines are to be maintained as part of the Temporary Traffic Signal Installation specified for on the plan. The interconnect, including any required fiber splices and terminations, shall be installed into the temporary controller cabinet as per the notes or details on the plans. All labor and equipment required to install and maintain the existing interconnect as part of the Temporary Traffic Signal Installation shall be included in the cost of TEMPORARY TRAFFIC SIGNAL INSTALLATION. When shown in the plans, temporary traffic signal interconnect equipment shall be furnished and installed. The temporary traffic signal interconnect shall maintain interconnect communications throughout the entire signal system for the duration of the project. Any temporary signal within an existing closed loop traffic signal system shall be interconnected to that system using similar brand control equipment at no additional cost to the contract.
3. Temporary wireless interconnect. The radio interconnect system shall be compatible with Eagle or Econolite controller closed loop systems. This work shall include all temporary wireless interconnect components, at the adjacent existing traffic signal(s) to provide a completely operational closed loop system. This work shall include all materials, labor and testing to provide the completely operational closed loop system as shown on the plans. The radio interconnect system shall include the following components:
 - a. Rack or Shelf Mounted RS-232 Frequency Hopping Spread Spectrum (FHSS) Radio
 - b. Software for Radio Configuration (Configure Frequency and Hopping Patterns)
 - c. Antennas (Omni Directional or Yagi Directional)
 - d. Antenna Cables, LMR400, Low Loss. Max. 100-ft from controller cabinet to antenna
 - e. Brackets, Mounting Hardware, and Accessories Required for Installation
 - f. RS232 Data Cable for Connection from the radio to the local or master controller
 - g. All other components required for a fully functional radio interconnect system

All controller cabinet modifications and other modifications to existing equipment that are required for the installation of the radio interconnect system components shall be included in the cost of TEMPORARY TRAFFIC SIGNAL INSTALLATION.

The radio interconnect system may operate at 900Mhz (902-928) or 2.4 Ghz depending on the results of a site survey. The telemetry shall have an

acceptable rate of transmission errors, time outs, etc. comparable to that of a hardware system.

The proposed or existing master controller and telemetry module shall be configured for use with the radio interconnect at a minimum rate of 9600 baud.

The radio interconnect system shall include all other components required for a complete and fully functional telemetry system and shall be installed in accordance to the vendors recommendations.

- (f) Emergency Vehicle Pre-Emption. All emergency vehicle preemption equipment (light detectors, light detector amplifiers, confirmation beacons, etc.) as shown on the temporary traffic signal plans shall be provided by the Contractor. It shall be the Contractor's responsibility to contact the municipality or fire district to verify the brand of emergency vehicle preemption equipment to be installed prior to the contract bidding. The equipment must be completely compatible with all components of the equipment currently in use by the Agency. All light operated systems shall operate at a uniform rate of 14.035 hz \pm 0.002, or as otherwise required by the Engineer, and provide compatible operation with other light systems currently being operated in the District. All labor and material required to install and maintain the Emergency Vehicle Preemption installation shall be included in the item Temporary Traffic Signal Installation.
- (g) Vehicle Detection. All temporary traffic signal installations shall have vehicular detection installed at all approaches of the intersection and as directed by the Engineer. Pedestrian push buttons shall be provided for all pedestrian signal heads/phases as directed by the Engineer. Microwave vehicle sensors or video vehicle detection system shall be approved by IDOT prior to Contractor furnishing and installing. The Contractor shall install, wire, and adjust the alignment of the microwave vehicle sensor or video vehicle detection system in accordance to the manufacturer's recommendations and requirements. The Contractor shall be responsible for adjusting the alignment of the microwave vehicle sensor or video vehicle detection system for all construction staging changes and for maintaining proper alignment throughout the project. An equipment supplier shall be present and assist the contractor in setting up and maintaining the microwave vehicle sensor or video vehicle detection system. An in-cabinet video monitor shall be provided with all video vehicle detection systems and shall be included in the item Temporary Traffic Signal Installation.
- (h) Uninterruptable Power Supply. All temporary traffic signal installations shall have Uninterruptable Power Supply (UPS). The UPS cabinet shall be mounted to the temporary traffic signal cabinet and shall be according to the applicable portions of Section 862 of the Standard Specifications and as modified in 862.01TS UNINTERRUPTABLE POWER SUPPLY, SPECIAL Special Provision.

- (i) Signs. All existing street name and intersection regulatory signs shall be removed from existing poles and relocated to the temporary signal span wire. If new mast arm assembly and pole(s) and posts are specified for the permanent signals, the signs shall be relocated to the new equipment at no extra cost. Any intersection regulatory signs that are required for the temporary traffic signal shall be provided as shown on the plans or as directed by the Engineer. Relocation, removing, bagging and installing the regulatory signs for the various construction stages shall be provided as shown on the plans or as directed by the Engineer. If Illuminated Street Name Signs exist they shall be taken down and stored by the contractor and reflecting street name signs shall be installed on the temporary traffic signal installation.
- (j) Energy Charges. The electrical utility energy charges for the operation of the temporary traffic signal installation shall be paid for by others if the installation replaces an existing signal. Otherwise charges shall be paid for under 109.05 of the Standard Specifications.
- (k) Maintenance. Maintenance shall meet the requirements of the Standard Specifications and 850.01TS MAINTENANCE OF EXISTING TRAFFIC SIGNAL INSTALLATION Special Provisions. Maintenance of temporary signals and of the existing signals shall be included in the cost of the TEMPORARY TRAFFIC SIGNAL INSTALLATION pay item. When temporary traffic signals are to be installed at locations where existing signals are presently operating, the Contractor shall be fully responsible for the maintenance of the existing signal installation as soon as he begins any physical work on the Contract or any portion thereof. In addition, a minimum of seven (7) days prior to assuming maintenance of the existing traffic signal installation(s) under this Contract, the Contractor shall request that the Resident Engineer contact the Bureau of Traffic Operations (847) 705-4424 for an inspection of the installation(s).
- (l) Temporary Traffic Signals for Bridge Projects. Temporary Traffic Signals for bridge projects shall follow the State Standards, Standard Specifications, Special Provisions and any plans for Bridge Temporary Traffic Signals included in the plans. The installation shall meet the Standard Specifications and all other requirements in this TEMPORARY TRAFFIC SIGNAL INSTALLATION specification. In addition all electric cable shall be aurally suspended, at a minimum height of 18 feet (5.5m) on temporary wood poles (Class 5 or better) of 45 feet (13.7 m) minimum height. The signal heads shall be span wire mounted or bracket mounted to the wood pole or as directed by the Engineer. The Controller cabinet shall be mounted to the wood pole as shown in the plans, or as directed by the Engineer. Microwave vehicle sensors or video vehicle detection system may be used in place of detector loops as approved by the Engineer.
- (m) Temporary Portable Traffic Signal for Bridge Projects.
 - 1. The controller and cabinet shall be NEMA type designed for NEMA TS2 Type 1 operation. Controller and LED signal displays shall meet the applicable Standard

Specifications and all other requirements in this TEMPORARY TRAFFIC SIGNAL INSTALLATION special provision.

2. Work shall be according to Article 701.18(b) of the Standard Specifications except as noted herein.
3. General.
 - a. The temporary portable bridge traffic signals shall be trailer-mounted units. The trailer-mounted units shall be set up securely and level. Each unit shall be self-contained and consist of two signal heads. The left signal head shall be mounted on a mast arm capable of extending over the travel lane. Each unit shall contain a solar cell system to facilitate battery charging. There shall be a minimum of 12 days backup reserve battery supply and the units shall be capable of operating with a 120 V power supply from a generator or electrical service.
 - b. All signal heads located over the travel lane shall be mounted at a minimum height of 17 feet (5m) from the bottom of the signal back plate to the top of the road surface. All far right signal heads located outside the travel lane shall be mounted at a minimum height of 8 feet (2.5m) from the bottom of the signal back plate to the top of the adjacent travel lane surface.
 - c. The long all red intervals for the traffic signal controller shall be adjustable up to 250 seconds in one-second increments.
 - d. As an alternative to detector loops, temporary portable bridge traffic signals may be equipped with microwave sensors or other approved methods of vehicle detection and traffic actuation.
 - e. All portable traffic signal units shall be interconnected using hardwire communication cable. Radio communication equipment may be used only with the approval of the Engineer. If radio communication is used, a site analysis shall be completed to ensure that there is no interference present that would affect the traffic signal operation. The radio equipment shall meet all applicable FCC requirements.
 - f. The temporary portable bridge traffic signal system shall meet the physical display and operational requirements of conventional traffic signals as specified in Part IV and other applicable portions of the currently adopted version of the Manual on Uniform Traffic Control Devices (MUTCD) and the Illinois MUTCD. The signal system shall be designed to continuously operate over an ambient temperature range between -30 °F (-34 °C) and 120 °F (48 °C). When not being utilized to inform and direct traffic,

portable signals shall be treated as non-operating equipment according to Article 701.11.

Basis of Payment.

This work shall be paid for at the contract unit price each for TEMPORARY TRAFFIC SIGNAL INSTALLATION, TEMPORARY BRIDGE TRAFFIC SIGNAL INSTALLATION, or TEMPORARY PORTABLE BRIDGE TRAFFIC SIGNAL INSTALLATION, the price of which shall include all costs for the modifications required for traffic staging, changes in signal phasing as required in the Contract plans, microwave vehicle sensors, video vehicle detection system, any maintenance or adjustment to the microwave vehicle sensors/video vehicle detection system, the temporary wireless interconnect system, temporary fiber optic interconnect system, all material required, the installation and complete removal of the temporary traffic signal, and any changes required by the Engineer. Each intersection will be paid for separately.

TEMPORARY TRAFFIC SIGNAL TIMING

Effective: May 22, 2002

Revised: July 1, 2015

890.02TS

Description.

This work shall consist of developing and maintaining appropriate traffic signal timings for the specified intersection for the duration of the temporary signalized condition, as well as impact to existing traffic signal timings caused by detours or other temporary conditions.

All timings and adjustments necessary for this work shall be performed by an approved Consultant who has previous experience in optimizing Closed Loop Traffic signal Systems for District One of the Illinois Department of Transportation. The Contractor shall contact the Traffic Signal Engineer at (847) 705-4424 for a listing of approved Consultants.

The following tasks are associated with TEMPORARY TRAFFIC SIGNAL TIMING.

- (a) Consultant shall attend temporary traffic signal inspection (turn-on) and/or detour meeting and conduct on-site implementation of the traffic signal timings.
- (b) Consultant shall be responsible for making fine-tuning adjustments to the timings in the field to alleviate observed adverse operating conditions and to enhance operations.
- (c) Consultant shall provide monthly observation of traffic signal operations in the field.
- (d) Consultant shall provide on-site consultation and adjust timings as necessary for construction stage changes, temporary traffic signal phase changes, and any other conditions affecting timing and phasing, including lane closures, detours, and other construction activities.
- (e) Consultant shall make timing adjustments and prepare comment responses as directed by the Area Traffic Signal Operations Engineer.
- (f) Return original timing plan once construction is complete.

Basis of Payment.

The work shall be paid for at the contract unit price each for TEMPORARY TRAFFIC SIGNAL TIMING, which price shall be payment in full for performing all work described herein per intersection. When the temporary traffic signal installation is turned on and/or detour implemented, 50 percent of the bid price will be paid. The remaining 50 percent of the bid price will be paid following the removal of the temporary traffic signal installation and/or detour.

REBUILD EXISTING HANDHOLE

Effective: January 1, 2002

Revised: July 1, 2015

895.04TS

This item shall consist of rebuilding and bringing to grade a handhole at a location shown on the plans or as directed by the Engineer. The work shall consist of removing the handhole frame and cover and the walls of the handhole to a depth of eight (8) inches below the finished grade.

Upon completion of the above work, four (4) holes, four (4) inches in depth and one half (1/2) inch in diameter, shall be drilled into the remaining concrete; one hole centered on each of the four handhole walls. Four (4) #3 steel dowels, eight (8) inches in length, shall be furnished and shall be installed in the drilled holes with a masonry epoxy.

All concrete debris shall be disposed of outside the right-of-way.

The area adjacent to each side of the handhole shall be excavated to allow forming. All steel hooks, handhole frame, cover, and concrete shall be provided to construct a rebuilt handhole according to applicable portions of Section 814 of the Standard Specification and as modified in 814.01TS HANDHOLES Special Provision. The existing frame and cover shall be replaced if it was damaged during removal or as determined by the Engineer.

Basis of Payment.

This work shall be paid for at the contract unit price each for REBUILD EXISTING HANDHOLE, which price shall be payment in full for all labor, materials, and equipment necessary to complete the work described above and as indicated on the drawings.

RELOCATE EXISTING PEDESTRIAN PUSH-BUTTON

Effective: August 4, 2017

895.06TS

Relocation.

Revise the last paragraph of Article 895.02 of the Standard Specifications to read:

When relocating an existing pedestrian push-button, the related sign shall be removed and installed at the new location. The push-button shall be installed according to Article 888.03. Mounting / extension brackets shall be used to assure that the push button is accessible from a paved or concrete surface and is in full compliance with ADA. Mounting / extension brackets shall not be paid for separately but shall be included in the cost of the RELOCATE EXISTING PEDESTRIAN PUSH-BUTTON pay item.

LAYER II (DATALINK) SWITCH (LCDOT)

Effective: October 1, 2016
Revised: January 26, 2018
LC801.01

Description: This work shall consist of furnishing and installing a Layer II Ethernet switch used to transmit data from one traffic signal cabinet to another traffic signal cabinet containing a Layer II switch or a Layer III (Network) switch.

Materials: The Layer II switch shall be a Cisco IE-2000-8TC-B Industrial Ethernet Switch with SFPs. The Layer II (Datalink) Switch shall be procured from the County's PASSAGE Consultant. The PASSAGE Consultant shall program this equipment for the appropriate location in the County's communication network.

General: The Layer II switch and its power supply shall be mounted to either a standard DIN rail or an equipment mounting channel in the cabinet. The power supply shall be hard-wired to the cabinet power, not plugged into one of the traffic signal cabinet power outlets.

Basis of Payment: This item will be paid for at the contract unit price each for LAYER II (DATALINK) SWITCH. The unit price shall include all equipment, materials, and labor required to furnish and install the switch, including all necessary connectors, cables, fiber optic jumpers, hardware, software, and other peripheral equipment required to place the switch in operation to the satisfaction of the Traffic Engineer.

REMOTE CONTROLLED VIDEO SYSTEM (LCDOT)

Effective: October 1, 2016

Revised: March 1, 2019

LC801.02

General: This work shall consist of furnishing and installing an IP based remote-controlled video system at a location designated by the Traffic Engineer. The work shall include a color camera, dome assembly, all mounting hardware, connectors, cables, power injectors, and related equipment necessary to complete the installation according to the manufacturer's specifications.

Materials: The PTZ camera shall be one of the following approved models:

- TKH Security Solutions PD1103Z2-E
- AXIS Q6055-E
- Cohu 4220HD

The Contractor shall furnish the required number of power injectors for the camera make and model selected, including operation of the camera heater, as well as all required mounting hardware, connectors, patch cables, and power supplies.

The system shall have anonymous FTP capabilities disabled by the vendor/equipment supplier or provide a feature for the user to disable the functionality through the standard internal menu.

Installation: The camera shall be installed as shown on the plans, either on the luminaire arm near the luminaire, or on the combination mast arm assembly pole, angled toward the center of the intersection using a mounting bracket compatible with the camera and procured from one of the approved camera manufacturers. When installed on the pole, the camera shall be mounted to provide a minimum of 12 inches clear space between face of the pole and the camera housing. When installed on the luminaire arm, the camera shall be installed with a 30-degree tilt-adjustable bracket. The camera and any external hardware and housing shall be installed with stainless steel straps.

All holes drilled into signal poles, mast arms, or posts shall require rubber grommets to prevent the chafing of wires.

The Contractor shall contact the Traffic Engineer prior to installing the camera and associated wiring, to receive final approval on the camera location.

If the Remote Controlled Video System will be connected to the Gigabit Ethernet network, then a Layer II (Datalink) Switch and/or a Layer III (Network) Switch shall be required. Layer II and Layer III switches shall be installed as shown on the plans.

The remote controlled video system shall be warrantied, free from material and workmanship defects for a period of three years from final acceptance.

Basis of Payment: This item will be paid for at the contract unit price per each for REMOTE CONTROLLED VIDEO SYSTEM. The unit price shall include all associated equipment, hardware, cables, materials and labor required to install the complete system in place and in operation to the satisfaction of the Traffic Engineer.

The OUTDOOR RATED NETWORK cable from the traffic signal cabinet will be paid for separately. If required, the LAYER II (DATALINK) SWITCH and/or the LAYER III (NETWORK) SWITCH will be paid for separately.

VIDEO DETECTION SYSTEM COMPLETE INTERSECTION (LCDOT)

Effective: October 1, 2016

Revised: March 1, 2019

LC801.03

Description: This work shall consist of furnishing and installing a system that monitors vehicles on a roadway via the processing of video images and that provides detector outputs to a traffic signal controller. This work shall consist of furnishing and installing video cameras, cables, video processors, a controller interface unit, and a remote communication module to operate the video vehicle detection system at one signalized intersection.

Materials: The Video Detection System Complete Intersection shall be one of the following systems:

- Autoscope Vision
- Iteris Vantage Next

All the cables from the detection cameras to the traffic signal cabinet and within the traffic signal cabinet itself shall be included in the cost of this item.

Surge protection and grounding shall be provided to protect the video detection cameras and components located in the traffic signal cabinet.

The system shall have anonymous FTP capabilities disabled by the vendor/equipment supplier or provide a feature for the user to disable the functionality through the standard internal menu.

Installation: The video detection camera shall be installed on top of the luminaire arm. Occasionally overhead utility wires may obstruct the camera's field of view and prevent proper detector placement. In the event of an obstructed view, the camera shall be installed on a J-hook below the luminaire arm, instead of the normal mounting bracket.

All holes drilled into signal poles, mast arms, or posts shall require rubber grommets to prevent the chafing of wires.

If the Video Detection System Complete Intersection will be connected to the Gigabit Ethernet network, it shall communicate over 10/100 Base T Ethernet to a Layer II (Datalink) Switch and/or a Layer III (Network) Switch. Layer II and Layer III switches shall be installed as shown on the plans.

The Video Detection System Complete Intersection shall be warrantied, free from material and workmanship defects for a period of three years from final acceptance.

Basis of Payment: This item will be paid for at the contract unit price per each for VIDEO DETECTION SYSTEM COMPLETE INTERSECTION. The unit price shall include all

associated equipment, hardware, cables, materials and labor required to install the system at one signalized intersection and in operation to the satisfaction of the Traffic Engineer.

If required, the cost of the J-hook shall be included in the cost of VIDEO DETECTION SYSTEM COMPLETE INTERSECTION. If required, the LAYER II (DATALINK) SWITCH and/or the LAYER III (NETWORK) SWITCH will be paid for separately.

RELOCATE EXISTING REMOTE-CONTROLLED VIDEO SYSTEM (LCDOT)

Effective: October 1, 2016
Revised: January 26, 2018
LC801.05

Description: This work shall consist of the removal, storage, and relocation of an existing remote-controlled video system from one traffic signal installation or light pole to another location.

General: The remote-controlled video system shall be removed and relocated as shown on the plans and/or as directed by the Traffic Engineer. Any damage sustained by the remote-controlled video system during the removal, storage, transport, and/or reinstallation operations shall be repaired or replaced in kind to the satisfaction of the Traffic Engineer at the Contractor's expense.

All holes drilled into signal poles, mast arms, or posts shall require rubber grommets to prevent the chafing of wires.

Basis of Payment: This item will be paid for at the contract unit price per each for RELOCATE EXISTING REMOTE-CONTROLLED VIDEO SYSTEM. The unit price shall include all equipment, materials and labor required to disconnect the existing remote-controlled video system; package and store it; transport it; install the complete system in the new location; and in operation to the satisfaction of the Traffic Engineer.

RELOCATE SWITCH (LCDOT)

Effective: October 1, 2016
Revised: March 1, 2019
LC801.06

Description: This work shall consist of the removal, storage, and relocation of an existing Layer II or Layer III switch and associated power supply, from one traffic signal, ITS, or communications cabinet to another cabinet.

General: The switch shall be removed and relocated as shown on the plans and/or as directed by the Traffic Engineer. Any damage sustained by the switch during the removal, storage, transport, and/or reinstallation operations shall be repaired or replaced in kind by the County's PASSAGE Consultant to the satisfaction of the Traffic Engineer at the Contractor's expense.

Basis of Payment: This item will be paid for at the Contract unit price each for RELOCATE SWITCH. The unit price shall include all equipment, materials and labor required to disconnect the existing switch; package and store it; transport it; install the switch in the new location; and in operation to the satisfaction of the Traffic Engineer. The unit price shall also include the all equipment, materials and labor required to disconnect the existing switch power supply and all fiber optic jumper cables; package and store them; transport them; install the power supply and all fiber optic jumper cables necessary for proper operation in the new location; and in operation to the satisfaction of the Traffic Engineer.

LAYER III (NETWORK) SWITCH (LCDOT)

Effective: December 5, 2017

Revised: August 1, 2018

LC801.13

Description: This work shall consist of furnishing and installing a Layer III network switch used to transmit data from the cabinet location shown on the plans to multiple locations having a Layer II or Layer III switch.

Materials: The Layer III switch shall be a Cisco IE-4010-16S12P switch. The Layer III switch shall include the PWR-RGD-AC-DC-H Power Supply, and L-IE4000-RTU= IP Services upgrade. The unit shall also include four GLC-FE-100LX-RGD= modules and four GLC-LH-SMD= modules.

The Layer III (Network) Switch shall be procured from the County's PASSAGE Consultant. The PASSAGE Consultant shall program this equipment for the appropriate location in the County's communication network.

General: The Layer III switch shall be installed in the traffic signal cabinet or communications cabinet as shown on the plans. The switch shall be mounted on the shelf inside the cabinet, or in another suitable location in the traffic signal cabinet with the approval of the Traffic Engineer. Any existing equipment or cables conflicting with the installation of the Layer III switch shall be repositioned in a workmanlike manner. The Layer III switch shall be plugged into the 15A power distribution unit inside the cabinet.

Basis of Payment: This item will be paid for at the Contract unit price per each for LAYER III (NETWORK) SWITCH. The unit price shall include all equipment, materials, and labor required to furnish and install the switch, including all necessary connectors, cables, fiber optic jumpers, hardware, software, fiber optic transceiver modules, and other peripheral equipment required to place the switch in operation to the satisfaction of the Traffic Engineer. If required, MEDIA CONVERTERS will be paid for separately.

RELOCATE EXISTING ENCODER (LCDOT)

Effective: November 1, 2017

Revised:

LC801.18

Description: This work shall consist of the removal, storage, and relocation of an existing video encoder from one traffic signal installation to another traffic signal installation.

General: The encoder shall be removed and relocated as shown on the plans. Any damage sustained to the encoder during removal, storage, transport, and/or reinstallation operations shall be repaired or replaced in kind to the satisfaction of the Engineer at the Contractors expense.

Basis of Payment: This item will be paid for at the contract unit price per each for RELOCATE EXISTING ENCODER. The unit price shall include all equipment, materials, and labor required to disconnect the existing video encoder; package and store it; transport it; install the encoder in the new location; and in operation to the satisfaction of the Traffic Engineer. The unit price shall also include all equipment, materials and labor required to disconnect the existing encoder power supply and all cable installations or connections necessary for proper operation in the new location; and in operation to the satisfaction of the traffic engineer.

MAINTENANCE OF EXISTING TRAFFIC SIGNAL INSTALLATION (LCDOT)

Effective: October 1, 2016

Revised:

LC850.01

Description: This work shall consist of maintaining an existing traffic signal installation that has been designated to remain in operation during construction.

General: This work will be performed according to Section 850 of the “Standard Specifications” and the following:

Full maintenance responsibility shall start as soon as the Contractor begins any physical work on the contract or any portion thereof.

The Contractor shall have electricians on staff with IMSA Level II certification to provide signal maintenance.

This item shall include maintenance of all traffic signal equipment at the intersection, including cameras, emergency vehicle pre-emption equipment, traffic counters, detection equipment, traffic signal control equipment, terminal servers, media converters, transit signal priority equipment, flashing beacons, uninterruptable power supply (UPS) and batteries, handholes, lighted signs, radios, modems, master controllers, telephone service installations, communication equipment, communication cables, conduits to adjacent intersections, and other traffic signal equipment.

Video encoders, layer II and layer III switches will be maintained by the County’s PASSAGE Consultant. The Contractor shall provide cabinet access to the PASSAGE Consultant as necessary to maintain communications on the PASSAGE network. Power supplies for encoders and switches shall be furnished by LCDOT. Any electrical work necessary to troubleshoot or replace power supplies shall be performed by the Contractor.

The Contractor will not be required to pay the energy charges for the operation of the existing traffic signal installation.

Maintenance will not include Automatic Traffic Enforcement equipment, e.g. red light enforcement cameras, detectors, or peripheral equipment. This equipment is operated and maintained by the local municipality and should be de-activated while the traffic signal is on Contractor maintenance.

The Contractor shall check all controllers every month, which will include opening the cabinet door and visually inspecting all timing intervals, relays, detectors, and pre-emption equipment to ensure that they are functioning properly. This item includes all portions of the emergency vehicle pre-emption system. The Contractor shall not clear equipment log buffers. The Contractor shall at all times maintain in stock a sufficient amount of materials and equipment to provide effective temporary and permanent repairs.

The Contractor shall provide immediate corrective action when any part of the system fails to function properly. Two far side heads facing each approach shall be considered the minimum acceptable signal operation pending permanent repairs. When repairs at a signalized intersection require that the controller be disconnected, and power is available, the Contractor shall place the traffic signal installation on flashing operation. The signals shall flash **RED** for all directions unless a different indication has been specified by the Traffic Engineer. When the signal is flashing **RED** or when the power is out, the Contractor shall be required to place at least 1 STOP sign (R1-1-36) meeting MUTCD requirements at each approach of the intersection as a temporary means of regulating traffic according to the Repair Timetable in the project special provisions. At approaches where a yellow flashing indication is directed by the Traffic Engineer, STOP signs will not be required. The Contractor shall maintain a sufficient number of STOP signs for all the signals under the Contractor's maintenance and have enough spare STOP signs in stock at all times to replace those which may be damaged or stolen.

The Contractor shall provide the Engineer with a 24-hour telephone number for traffic signal maintenance. The Contractor, or his representative, shall be available on a 24-hour basis to respond to emergency calls by the Engineer, Traffic Engineer or other parties.

Traffic signal equipment which is lost or not returned to the County for any reason shall be replaced with new equipment meeting the requirements of the project special provisions and "Standard Specifications", or in the absence of applicable specifications, meeting the requirements of the Traffic Engineer.

The Contractor shall respond to all emergency calls from the County or others according to the Repair Timetable and provide immediate corrective action. When equipment has been damaged or becomes faulty beyond repair, the Contractor shall replace it with new and identical equipment. The cost of furnishing and installing the replaced equipment shall be borne by the Contractor at no additional charge to the County. The Contractor may initiate action to recover damages from a responsible third party. If at any time the Contractor fails to perform all work as specified herein to keep the traffic signal installation in proper operating condition or if the Engineer or Traffic Engineer cannot contact the Contractor's designated personnel, the Traffic Engineer shall have the County's Traffic Signal Maintenance Contractor perform the required maintenance work. The County's Traffic Signal Maintenance Contractor shall bill the Contractor for the total cost of the work. The Contractor shall pay this bill within 30 days of the date of receipt of the invoice or the cost of such work will be deducted from the amount due the Contractor. The Contractor shall allow the County's Traffic Signal Maintenance Contractor to open the cabinet and review the operation of the existing traffic signal installation that has been transferred to the Contractor for maintenance.

The Traffic Engineer may require the Contractor to transfer maintenance of a signal back to the County's Traffic Signal Maintenance Contractor (or other electrical contractor) for a short time. This may become necessary due to other signal projects in the area, or if the County needs to perform work at the signal. Any costs incurred by the Contractor for maintenance transfer inspections of this type shall be included in cost of pay item MAINTENANCE OF EXISTING TRAFFIC SIGNAL INSTALLATION.

Any proposed activity in the vicinity of a highway-rail grade crossing shall adhere to the guidelines set forth in the current edition of the Manual on Uniform Traffic Control Devices (MUTCD) regarding work in temporary traffic control zones in the vicinity of highway-rail grade crossings which states that lane restrictions, flagging, or other operations shall not create conditions where vehicles can be queued across the railroad tracks. If the queuing of vehicles across the tracks cannot be avoided, a uniformed law enforcement officer or flagger shall be provided at the crossing to prevent vehicles from stopping on the tracks, even if automatic warning devices are in place.

Temporary replacement of damaged or knockdown of a mast arm pole assembly shall require construction of a full or partial span wire signal installation or other method approved by the Traffic Engineer.

Basis of Payment: This work shall be paid for at the Contract unit price each for MAINTENANCE OF EXISTING TRAFFIC SIGNAL INSTALLATION. Each intersection will be paid for separately.

FULL-ACTUATED CONTROLLER AND TYPE IV CABINET, SPECIAL (LCDOT)

Effective: October 1, 2016
Revised: March 1, 2019
LC857.01

Description: This work shall consist of furnishing and installing a full-actuated controller and type IV cabinet at locations shown on the plans and/or as designated by the Traffic Engineer.

General: This work shall be performed according to Sections 857 and 863 of the “Standard Specifications” and the following:

The controller shall conform to ITE ATC Version 6. The controller shall be the latest model available that is compatible with “*Centracs*” software, currently in use by LCDOT. The controller software compatibility requirements are based upon the controller’s location in the communication system, and shall be as shown on the plans. The controller shall have the latest version of NTCIP software compatible with “*Centracs*” installed, and be equipped with advanced display, 2 Ethernet ports minimum and a removable data key to save the controller database.

The cabinet shall be designed for NEMA TS2 Type 1 operation. The cabinet shall be pre-wired for a minimum of eight phases of vehicular; four phases of pedestrian; and four phases of overlap operation. Individual load switches shall be provided for each vehicle, pedestrian and right turn overlap phase.

- **Cabinets:** Controller cabinets shall have a footprint of approximately 44 inches wide by 26 inches deep. Type IV cabinets shall be 65 inches high, and shall provide a third shelf for mounting additional equipment. The cabinets shall be fabricated of 1/8" thick unpainted aluminum alloy 5052-H32. The surface shall be smooth and free of marks and scratches. All external hardware shall be stainless steel.
- **Cabinet Doors:** The cabinet shall include front and rear doors of NEMA type 3R construction with a cellular neoprene gasket that is rain tight. The door hinges shall be continuous 14-gauge stainless steel and shall be secured with ¼-20 stainless steel carriage bolts. The standard equipment shall include a three-point locking system that secures the door at the top, bottom and center. A corbin lock with two keys shall also be furnished. The door shall be equipped with a two-position doorstop, one at 90° and one at 120°.
- **Controller Harness:** The cabinet shall include a TS2 Type 2 “A” harness in addition to the TS2 Type 1 harness.
- **Surge Protection:** The cabinet shall have a 120VAC Single Phase Modular filter Plug-in type, supplied from an approved vendor.
- **BIU:** The BIU shall be secured by mechanical means.
- **Switch Guards:** All switches shall include switch guards.
- **Back Panel:** The back panel wiring shall be securely covered with a piece of Plexiglas. The Plexiglas shall have a minimum thickness 1/8-inch.

- **Heating:** The cabinet shall include one 200-watt, thermostatically-controlled, electric heater.
- **Lighting:** The cabinet shall include four LED light assemblies along the top and sides of the cabinet. The LED panels shall be controlled by a door switch. The LED Panels shall be provided from an approved vendor.
- **Plan & Wiring Diagrams:** The cabinet shall include a 12" x 15" moisture sealed container attached to door for plan and wiring diagrams.
- **Pull-out Drawer:** The cabinet shall be equipped with a pull-out drawer/shelf assembly. A 1½ inch deep drawer shall be provided in the cabinet, mounted directly beneath the controller support shelf. The drawer shall have a hinged top cover and shall be capable of accommodating one complete set of cabinet prints and manuals. This drawer shall support 50 pounds in weight when fully extended. The drawer shall open and close smoothly. The drawer dimensions shall make maximum use of available depth offered by the controller shelf and be a minimum of 18 inches wide.
- **Detector Racks:** The cabinet shall include a full-size rack fully wired to support one BIU, sixteen channels of vehicle detection, and four channels of EVP.
- **Field Wiring Labels:** All field wiring shall be labeled.
- **Field Wiring Termination:** Approved channel lugs shall be required for all filed wiring termination.
- **Power Supply:** The power supply shall include a nonconductive shield.
- **Circuit Breaker:** The signal circuit breaker shall be sized for the proposed load. The signal circuit breaker shall be rated a minimum of 30 amps.
- **Police Door:** The controller shall include wiring and termination for a plug-in manual phase advance switch.
- **Railroad Pre-Emption Test Switch:** A railroad pre-emption test switch shall be provided from an approved vendor.
- **Malfunction Management Unit (MMU):** The cabinet shall include a 16 Channel, LCD display, IP addressable (Ethernet) MMU. The MMU shall be connected to the Ethernet switch with a CAT 5e cable, and configured for proper communication.
- **Door Alarm:** The front and rear doors shall be equipped with switches wired to the traffic signal controller alarm 1 input for logging and reporting of a door open condition.
- **Photocell:** Photocell shall be rated 105-305V, turn on at 1.5 fcs. with a 3-5 second delay and shall operate a contactor sized for the signs and lights shown on the plans. The photocell shall be installed under the front lip of the cabinet in a drilled hole. A manufacturer's warranty of six years shall be provided for the photocell. Photocell power consumption shall be no greater than 1 watt at 120V. The photocell and contactor shall be wired to operate all internally illuminated street name signs and combination street lights at the intersection. The photocell and contactor shall be wired so that the fixtures are not operational when the signal operates under battery or generator power. The photocell and contactor shall be configured so that light fixtures and signs will be energized if the photocell fails.

The full-actuated controller shall be warrantied, free from material and workmanship defects for a period of three years from final acceptance.

Basis of Payment: This item will be paid for at the Contract unit price per each for FULL-ACTUATED CONTROLLER AND TYPE IV CABINET, SPECIAL. The unit price shall include all equipment, materials and labor required to furnish and install the cabinet and controller, complete with necessary connections and equipment for proper operation.

FIBER OPTIC CABLE (LCDOT)

Effective: October 1, 2016

Revised:

LC871.01

Description: This work shall consist of furnishing and installing all accessories required and fiber optic cable of the type, size, and number of fibers specified.

Materials: The Fiber Optic Cable shall meet the requirements of Article 1076.02 of the “Standard Specifications” and the following:

The Fiber Optic Cable may be gel filled or have an approved water blocking tape.

General: This work shall be performed according to Section 871 of the “Standard Specifications” and the following:

This work shall consist of furnishing and installing fiber optic cable in conduit with all accessories and connectors. The cable shall be of the type, size, and the number of fibers specified with a maximum of twelve fibers per buffer tube. The work includes making all fiber splices and terminations to the proposed fiber optic cable as indicated on the plans and/or as directed by the Traffic Engineer.

The distribution enclosure shall be wall-mountable with capacity for four closet connector housing panels per enclosure and up to eight 0.2-inch or four 0.4-inch reduced length splice trays. The enclosure dimensions shall not exceed 13.5” x 8.5” x 4.5”. The enclosure shall be capable of accommodating the required number of fibers. The distribution enclosure shall be included in the cost of FIBER OPTIC CABLE of the type, size, and number of fibers specified, including connections to any existing cables.

All fibers being terminated shall be connected to the distribution enclosure and labeled at the connector and also at the enclosure bulkhead. The label shall include the direction and also the fiber number (e.g. S1, S2, N11, N12).

All splices and terminations on the installed fiber optic cable shall be included in the cost of the fiber optic cable, including the splicing of the installed fiber optic cable to any existing fiber optic cable. Splice trays and connector bulkheads required for the installed fiber optic cable shall be included in the cost of FIBER OPTIC CABLE of the type, size, and number of fibers specified.

All terminations and splices required only on existing fiber optic cable shall be paid for separately according to the pay item TERMINATE FIBER IN CABINET or SPLICE FIBER IN CABINET.

A minimum of 13 feet of slack cable shall be provided for the controller cabinet. The controller cabinet slack cable shall be stored as directed by the Traffic Engineer.

The quality of the fiber optic cable, including all splices and terminations, shall be verified by testing and documentation according to Article 801.13(d) of the “Standard Specifications”, to the satisfaction of the Traffic Engineer.

Multimode: When multimode fiber is required, the Contractor shall coordinate with the equipment supplier, and shall terminate as many multimode fibers as are necessary to establish proper communications between new and/or existing signal controllers and/or video transmission equipment. In addition, the Contractor shall terminate four unused multimode fibers and attach them to the distribution enclosure. All multimode terminations shall be ST compatible connectors with ceramic ferrules.

Singlemode: The Contractor shall splice and/or terminate the number of singlemode fibers shown on the project plans, if any, according to the following requirements:

Singlemode Fiber Terminations: All singlemode fiber terminations shall utilize pre-fabricated, factory-terminated (SC compatible with ceramic ferrules) pigtailed fusion spliced to bare fibers. The pre-fabricated pigtailed shall have all of their fibers color coded to match the singlemode fibers in the fiber optic cable. Connector bulkheads shall be the proper type for the fiber enclosure at the location, and shall be properly secured to the enclosure.

Singlemode Fiber Splices: All splices shall be made using a fusion splicer that automatically positions the fibers using a system of light injection and detection. The Contractor shall provide all equipment and consumable supplies.

Splices shall be secured in fiber optic splice trays within fiber optic distribution enclosures. All fusion splices shall be secured on aluminum splice trays capable of accommodating the required number of fusion splices, including necessary splice holders and a compatible splice tray cover. The tray dimensions shall not exceed 7.5” x 4.1” x 0.45” and shall be mounted within the enclosure using suitable hardware that allows removal for maintenance purposes without the use of tools. All individual splice trays shall be labelled.

All optical fibers shall be spliced to provide continuous runs. Splices shall only be allowed in equipment cabinets except where otherwise shown on the plans.

Basis of Payment: The work shall be paid for at the contract unit price per foot for FIBER OPTIC CABLE of the type, size, and number of fibers specified. The unit price shall include distribution enclosure(s), all connectors, pigtailed, splice trays, connector bulkheads, testing and documentation, and the required number of fiber splices and terminations shown on the plans. Additional fiber terminations and/or splices required by the Traffic Engineer, (not included in this item), shall be paid for as TERMINATE FIBER IN CABINET and/or SPLICE FIBER IN CABINET.

ELECTRIC CABLE (LCDOT)

Effective: October 1, 2016

Revised: October 1, 2017

LC873.01

Description: This work shall consist of furnishing and installing an electric cable of the type, size and number of conductors specified.

Materials: The electric cable shall meet the requirements of Article 1076.04 of the “Standard Specifications” and the following:

- Signal Cable: The conductors for signal cable shall be limited to No. 14 AWG solid copper.
- Service Cable: The service cable may be either single or multiple conductor cable.
- The electric service cable shall have an XLP jacket.
- All other cable jackets shall be polyvinyl chloride, meeting the requirements of IMSA 19-1 or IMSA 20-1.
- The jacket color for signal cable shall be black.
- The jacket color for lead-in and communications cable shall be gray.
- All cabling between the signal cabinet and the signal heads shall be solid copper, not multi-stranded.
- Heat shrink splices shall be used according to the District 1 “Standard Traffic Signal Design Details” as shown on the plans.

General: This work shall be performed according to Section 873 of the “Standard Specifications”.

Method of Measurement: Electric Cable will be measured for payment in feet according to Article 873.05 of the “Standard Specifications”.

Basis of Payment: This work will be paid for at the contract unit price per foot for ELECTRIC CABLE, of the method of installation (IN TRENCH, IN CONDUIT, or AERIAL SUSPENDED), of the type, size and number of conductors or pairs specified.

OUTDOOR RATED NETWORK CABLE (LCDOT)

Effective: October 1, 2016

Revised: July 15, 2017

LC873.02

Description: This work shall consist of furnishing and installing a network cable from the traffic signal cabinet to the associated field device as shown on the plans.

Materials: The outdoor rated network cable shall be a black Category 5e cable, meeting the TIA/EIA 568-B.2 telecommunication standards. The cable shall be composed of 24 AWG solid bare copper conductors, twisted pairs, polyolefin insulation, inner LLPE jacket, overall shield (100% coverage), 24 AWG stranded TC drain wire, industrial grade sunlight- and oil-resistant LLPE jacket. The cable shall be capable of performing from -40 °F to 160 °F.

Each end of the cable shall be terminated with an RJ-45 connector installed according to the TIA/EIA 568B standard. The drain wire at the cabinet end shall be terminated with a ring lug and attached to a suitable ground point.

General: The work shall be performed according to the applicable portions of Section 873 of the “Standard Specifications”, and details as shown on the plans.

Basis of Payment: This work will be paid for at the contract unit price per foot for OUTDOOR RATED NETWORK CABLE. The unit price shall include all equipment, materials and labor required to furnish and install the cable, and making all connections necessary for proper operation. The unit price shall also include furnishing and installing the RJ-45 connectors, ring terminals and grounding the cable.

TRAFFIC SIGNAL POST (SPECIAL) (LCDOT)

Effective: October 1, 2016

Revised:

LC875.01

Description: This work shall consist of furnishing and installing a metal traffic signal post at locations shown on the plans and/or as directed by the Traffic Engineer.

Materials: The traffic signal post shall meet the requirements of Article 1077.01 of the “Standard Specifications” and the following:

The traffic signal post shall be made of extruded aluminum, 16 feet in height, unless otherwise shown on the plans. The base shall be cast aluminum.

The traffic signal post and associated base shall be manufactured and/or supplied by Beacon, Sternberg Vintage Lighting, or Valmont, according to the following:

- Round, straight (non-tapered), 5-inch diameter, 12-flat fluted post.
- A ball center cap for the top of the post, instead of a tenon.
- The base section of the post shall be approximately 43 inches tall.

Manufacturer designations for TRAFFIC SIGNAL POST (SPECIAL) include the following:

- Beacon (MainStreet Series (100SJ)) base
- Sternberg (Hamilton Series (5400D)) base
- Valmont

The traffic signal post and associated base shall be assembled and any exposed steel hardware shall be hot-dipped galvanized and powder-coated black by the supplier/manufacturer, as described below or by a pre-approved alternative finishing method. Cast aluminum base covers shall be powder-coated black by the supplier/manufacturer, as described below or by a pre-approved alternative finishing method.

Powder-Coated Finish: All galvanized and aluminum exterior surfaces shall be coated with chip resistive epoxy resin primer applied via electrostatic spray equipment. The primer is to be applied at a minimum dry film thickness (DFT) of 3.0 mils with a minimum DFT of 6.0 mils applied to the lower 8 feet of the pole. The primer coat shall be energy absorptive, and capable of achieving a rating of 10A under testing according to the American Society for Testing and Materials (ASTM) Procedure D3170, Standard Test Method for Chipping Resistance of Coatings. The primed surfaces shall then be coated with a black semi-gloss TGIC Super Durable Polyester topcoat to a minimum dry film thickness of 3.0 mils. The topcoat shall meet the requirements of the American Architectural Manufacturer’s Association (AAMA) 2604 test for color and gloss retention properties.

The manufacturer shall warranty the finish of all components for a period of at least five years from the date of shipment. The Contractor shall provide a copy of the warranty to the Traffic Engineer, upon request.

General: This work shall be performed according to Section 875 of the “Standard Specifications” and the following:

All chips, scrapes, scratches, etc., in the paint shall be touched-up by the Contractor according to the manufacturer’s recommendations, with matching paint supplied by the manufacturer.

All holes drilled into signal poles, mast arms, or posts shall require rubber grommets to prevent the chafing of wires.

Pedestrian pushbutton stations shall be mounted to mast arm base covers according to the following:

- The top and bottom of the station shall be secured by drilling, tapping, and installing a 3/8-inch stainless steel threaded bolt, lock washer, and hex nut. Do not use self-tapping screws.
- Spacers made of 3/4-inch aluminum conduit shall be installed behind the pushbutton station, to level and plumb the station.

Basis of Payment: This work will be paid for at the contract unit price per each for TRAFFIC SIGNAL POST (SPECIAL) of the length specified.

STEEL MAST ARM ASSEMBLY AND POLE (SPECIAL) (LCDOT)
STEEL COMBINATION MAST ARM ASSEMBLY AND POLE (SPECIAL) (LCDOT)

Effective: October 1, 2016

Revised:

LC877.01

Description: This work shall consist of furnishing and installing a steel mast arm assembly and pole or steel combination mast arm assembly and pole at locations shown on the plans and/or as directed by the Traffic Engineer.

Materials: The steel mast arm assembly and pole and steel combination mast arm assembly and pole shall meet the requirements of Article 1077.03 of the “Standard Specifications” and the following:

Steel mast arm assembly and pole and steel combination mast arm assembly and pole shall be manufactured and/or supplied by Sternberg Vintage Lighting, or Valmont, according to the following:

- Round, tapered, 16-sharp fluted pole.
- Round, tapered, smooth, standard-curved, flange-connected, traffic signal mast arm

The two-piece mast arm base cover shall be cast aluminum, and shall be manufactured and/or supplied by the same company as the mast arm assembly and pole. Manufacturer designations for the two-piece mast arm base cover to be used with (SPECIAL) MAST ARM ASSEMBLIES include the following:

- Sternberg (Hamilton 6401SS)
- Valmont (Lake County AC1 base cover)

All mast arms, mast arm poles, luminaire arms, and any exposed steel hardware shall be hot-dipped galvanized, and then powder-coated black by the supplier/manufacturer, as described below or by a pre-approved alternative finishing method. Cast aluminum base covers shall be powder-coated black by the supplier/manufacturer, as described below or by a pre-approved alternative finishing method.

Powder-Coated Finish: All galvanized and aluminum exterior surfaces shall be coated with chip resistive epoxy resin primer applied via electrostatic spray equipment. The primer is to be applied at a minimum dry film thickness (DFT) of 3.0 mils with a minimum DFT of 6.0 mils applied to the lower 8 feet of the pole. The primer coat shall be energy absorptive, and capable of achieving a rating of 10A under testing according to the American Society for Testing and Materials (ASTM) Procedure D3170, Standard Test Method for Chipping Resistance of Coatings. The primed surfaces shall then be coated with a black semi-gloss TGIC Super Durable Polyester topcoat to a minimum dry film thickness of 3.0 mils. The topcoat shall meet the

requirements of the American Architectural Manufacturer's Association (AAMA) 2604 test for color and gloss retention properties.

The manufacturer shall warranty the finish of all components for a period of at least five years from the date of shipment. The Contractor shall provide a copy of the warranty to the Traffic Engineer, upon request.

General: This work shall be performed according to Section 877 of the "Standard Specifications" and the following:

All chips, scrapes, scratches, etc., in the paint shall be touched-up by the Contractor according to the manufacturer's recommendations, with matching paint supplied by the manufacturer.

All holes drilled into signal poles, mast arms, or posts shall require rubber grommets to prevent the chafing of wires.

Stainless steel mesh screening shall be stainless steel banded to the anchor bolts, with a minimum 2-inch lap, to enclose the void between the top of the foundation and the base plate. The mesh screening shall have ¼-inch maximum opening and a minimum wire diameter of AWG NO. 16. The screening shall not be installed until the Traffic Engineer has inspected the leveling nuts at the Traffic Signal "Turn-On".

All base covers shall fit tightly around the poles, with little or no gap at the top of the base cover. Two-piece base covers shall fit together tightly, with little or no gap between the two pieces. All base covers shall fit securely on top of the foundation, and shall not easily move or wobble. All base covers shall have an access hand hole, with a removable cover, and a minimum opening size of 200 square inches.

Pedestrian pushbutton stations shall be mounted to mast arm base covers according to the following:

- The top and bottom of the station shall be secured by drilling, tapping, and installing a 3/8-inch stainless steel threaded bolt, lock washer, and hex nut. Do not use self-tapping screws.
- Spacers made of 3/4-inch aluminum conduit shall be installed behind the pushbutton station, to level and plumb the station.

Luminaire arms shall be steel, 20 feet in length, tapered, monotube style, with an AASHTO 2001 wrap-around, gusset style connection.

Luminaires shall be installed at a minimum mounting height of 45 feet unless indicated otherwise on the plans, and shall be paid for separately.

Basis of Payment: This work will be paid for at the contract unit price per each for STEEL MAST ARM ASSEMBLY AND POLE (SPECIAL) or STEEL COMBINATION MAST ARM ASSEMBLY AND POLE (SPECIAL), of the signal arm length specified.

CONCRETE FOUNDATION (LCDOT)

Effective: October 1, 2016

Revised:

LC878.01

Description: This work shall consist of constructing a concrete foundation for a traffic signal post, controller base, or mast arm at locations shown on the plans and/or as directed by the Traffic Engineer.

General: This work shall be performed according to Section 878 of the “Standard Specifications” and the following:

All anchor bolts shall be according to Article 1006.09 of the “Standard Specifications”, except all anchor bolts shall be hot dipped galvanized the full length of the anchor bolt including the hook.

Concrete Foundations, Type A for Traffic Signal Posts shall provide anchor bolts with the bolt pattern specified within the District 1 “Standard Traffic Signal Design Details” as shown on the plans. All Type A foundations shall be a minimum of 48 inches deep.

Concrete Foundations, Type C (Special) for Traffic Signal Cabinets with Uninterruptable Power Supply (UPS / Battery Back-Up) cabinet installations shall be constructed according to the latest version of IDOT Standard 878001, except as modified herein. The constructed foundation shall be a minimum of 48 inches long by 31 inches wide, and shall have a minimum depth of 48 inches. An integral concrete pad foundation for the UPS cabinet shall be constructed a minimum of 31 inches long by 20 inches wide by 10 inches deep. The UPS cabinet pad foundation shall be integral to the side of the signal cabinet foundation, and shall be constructed on the same side as the signal cabinet power panel. Anchor bolts shall be provided and spaced according to the cabinet manufacturer’s specifications. The conduits shall be the number and size as shown in the plans and placed at minimum depth of 30 inches. An L-Shaped concrete apron shall be constructed along the entire front of the signal cabinet foundation, the entire side of the UPS cabinet foundation, and the entire front of the UPS cabinet foundation. This concrete apron shall be a minimum of 36 inches wide by five inches deep. Perpendicular grooves shall be installed in each direction in the concrete apron according to Article 424.06 of the “Standard Specifications”, beginning at the interior corner of the L shaped apron.

Concrete Foundations, Type D for Traffic Signal Cabinets shall be constructed according to the latest version of IDOT Standard 878001, except as modified herein. The constructed foundation shall be a minimum of 48 inches long by 31 inches wide, and shall have a minimum depth of 48 inches. Anchor bolts shall be provided and spaced according to the cabinet manufacturer’s specifications. The conduits shall be the number and size as shown in the plans and placed at minimum depth of 30 inches. The concrete apron at the signal cabinet shall be constructed a minimum of 36 inches wide by 48 inches long by five inches deep.

Concrete Foundations, Type E for Mast Arm and Combination Mast Arm Poles shall be constructed according to the latest version of IDOT Standard 878001. The foundation shall be 15 feet deep, except when deeper foundations are called for in IDOT Standard 878001.

The Engineer shall approve the foundation excavation prior to placing any concrete.

Basis of Payment: This work will be paid for at the contract unit price per foot of depth for CONCRETE FOUNDATION, of the type specified.

LED INTERNALLY ILLUMINATED STREET NAME SIGN (LCDOT)

Effective: October 1, 2016

Revised: July 15, 2017

LC891.01

Description: This work shall consist of furnishing a street name sign which is internally illuminated with light emitting diodes, and installing the sign on a traffic signal mast arm or span wire.

Materials: The LED Street Name Sign shall be one of the following approved models:

- Southern Manufacturing Clean Profile
- Temple Edge-Lit Razor
- Traffic Signs, Inc. ULTRASlim

The Contractor shall furnish the required mounting hardware.

3M Diamond Grade (ASTM Type IX) retroreflective sign sheeting shall be used for all sign legend and background surfaces.

All exterior metal surfaces of the sign housing shall be powder coated black by the supplier/manufacturer.

The electrical sign components shall be UL Listed and the light emitting diodes shall have a documented life span of 60,000 hours to 70% of the initial brightness. The sign faces shall display a minimum of 400 Lux when measured at any point and the lighting shall be spread evenly across each face of the sign.

The manufacturer shall warranty the entire sign, including all components, for a period of at least five years from the date of installation. The Contractor shall provide a copy of the warranty to the Traffic Engineer upon request.

Installation: The LED Street Name Sign shall be installed as shown on the plans, suspended from the mast arm unless a different mounting is called for, using a mounting bracket compatible with the sign model and manufacture.

All holes drilled into signal poles, mast arms, or posts shall require rubber grommets to prevent the chafing of wires.

The signs shall not be energized when traffic signals are powered by an alternate energy source such as a generator or uninterruptable power source (UPS).

All signs at the intersection shall be activated by a common photocell installed in the controller cabinet.

General: The sign shall be mounted on the mast arm three feet to the right of the furthest right signal head, as viewed by the approaching traffic.

The Manufacturer/Vendor shall supply shop drawings of the fixtures, sign, sign message and mounting hardware for approval. All hardware used to install the sign shall be according to the manufacturer's recommendations.

Basis of Payment: This work will be paid for at the contract unit price per each for LED INTERNALLY ILLUMINATED STREET NAME SIGN, of the size specified. The unit price shall include all associated equipment; hardware; wiring; connections; materials and labor required to furnish and install the sign, and place it in operation to the satisfaction of the Traffic Engineer. The #14 2/C cable from the signal cabinet to the sign shall be paid for separately. The photocell in the signal cabinet shall be paid for in FULL-ACTUATED CONTROLLER AND TYPE IV CABINET, SPECIAL or MODIFY EXISTING CONTROLLER CABINET.

REMOVE EXISTING TRAFFIC SIGNAL EQUIPMENT (LCDOT)

Effective: July 15, 2017

Revised:

LC895.01

Add the following to Article 895.05(a) of the Standard Specifications:

The traffic signal equipment which is to be removed and is to become the property of the Contractor shall be disposed of outside the right-of-way at the Contractor's expense.

All equipment to be returned to the Lake County Division of Transportation (LCDOT) shall be delivered by the Contractor to the LCDOT. The Contractor shall contact the LCDOT Traffic Signal Engineer at 847-377-7000 to schedule an appointment to deliver the equipment. No equipment will be accepted without a prior appointment. All equipment shall be delivered within 30 days of removing it from the traffic signal installation. The Contractor shall provide one hard copy and one electronic file of a list of equipment that is to remain the property of the LCDOT, including model and serial numbers, where applicable. The Contractor shall also provide a copy of the Contract plan or special provision showing the quantities and type of equipment.

Controllers and peripheral equipment from the same location shall be boxed together (equipment from different locations may not be mixed) and all boxes and controller cabinets shall be clearly marked or labeled with the location from which they were removed. If equipment is not returned according to these requirements, it will be rejected by the LCDOT. The Contractor shall be responsible for the condition of the traffic signal equipment from the time Contractor takes maintenance of the signal installation until the acceptance of a receipt drawn by the LCDOT Traffic Signal Engineer indicating the items have been returned in good condition.

The Contractor shall safely store and arrange for pick up or delivery of all equipment to be returned to agencies other than the LCDOT. The Contractor shall package the equipment and provide all necessary documentation as stated above.

Traffic signal equipment which is lost or not returned to the LCDOT for any reason shall be replaced with new equipment meeting the requirements of these Specifications at no cost to the contract.

For all traffic signal posts or mast arms to remain, all vacated holes remaining in existing posts or mast arms shall be plugged with a kneadable, two-part epoxy putty. The putty shall cure in two hours or less and, when dried, the putty shall be sandable and paintable. It shall be capable of withstanding up to 500 degree Fahrenheit temperatures, with minimum tensile strength of 6000 psi and compressive strength of 18 psi. Products that include asbestos are prohibited.

The epoxy putty shall be applied to each vacated hole according to manufacturer's recommendations. The putty shall be shaped and smoothed, and excess putty shall be removed before it hardens. After the putty is fully hardened, it shall be sanded, cleaned, and painted to match the traffic signal post or mast arm.

RELOCATE EXISTING ITS CONTROLLER CABINET

Description: This work shall consist of the removal, storage, and relocation of an existing communications cabinet from one traffic signal installation to another traffic signal installation. This work shall also include the relocation of existing equipment from the communications cabinet to a traffic signal controller cabinet.

General: The communications cabinet with all equipment shall be relocated to a new location adjacent to the temporary controller cabinet where it will not be impacted by construction as shown on the plans or as directed by the Engineer. The relocation of all existing equipment within the communications cabinet shall be included in this item. The communications cabinet shall be connected to the temporary traffic signal installation. Any damage sustained to the equipment during removal, reinstallation and/or reconnection operations shall be repaired or replaced in kind to the satisfaction of the Engineer and Lake County at the Contractor's expense.

Prior to disconnecting the communications cabinet, the Contractor shall contact the Traffic Engineer. The interruption of communication shall be kept to an absolute minimum, as described in the INTERRUPTION OF COMMUNICATION section of the LAKE COUNTY DOT TRAFFIC SIGNAL GENERAL REQUIREMENTS special provision. All existing communication and/or network connections shall be re-established after the communications cabinet is relocated.

Upon removal of the temporary traffic signal installation, the splice trays and fiber enclosure boxes shall be relocated from the existing communications cabinet to the proposed traffic signal controller cabinet. The existing communications cabinet shall be returned to Lake County. All equipment within the communications cabinet that is not being relocated to the permanent traffic signal installation(s) shall be returned to Lake County.

Basis of Payment: This item will be paid for at the contract unit price per each for RELOCATE EXISTING ITS CONTROLLER CABINET. The unit price shall include all equipment, materials, and labor required to disconnect and remove the existing cabinet and equipment, package and store it, transport it, install the communications cabinet and equipment in the new location and in operation to the satisfaction of the Traffic Engineer. The unit price shall also include the relocation of the existing splice trays and fiber enclosure boxes from the existing communications cabinet to the proposed traffic signal controller cabinet.

RELOCATE EXISTING ADAPTIVE CONTROL SYSTEM

Description: This work shall consist of the removal, storage, transport, and relocation of an existing Adaptive Control System from one traffic signal installation to another location.

General: The Contractor shall remove all associated existing equipment related to the Adaptive Control System, deliver the equipment to LCDOT for storage during construction, and pick up the equipment from LCDOT for installation onto the new traffic signal installation.

The existing Adaptive Control System is InSync, previously procured from Rhythm Engineering, the County's Adaptive Signal System Deployment Consultant. Associated equipment may include, but is not limited to, video detection cameras, InSync Processor, SDLC module, Pedestrian intercept module, DIN relay, InSync power supply, customized InSync cables, ethernet cables, SDLC cables, Ethernet repeater(s) (Veracity OUTREACH Lite XT [In-line Ethernet extender/repeater] with Veracity OUTSOURCE Plus PoE injector) in the access panel of the mast arm where the camera is located and all brackets associated with the video detection cameras, including, but not limited to, the extension from the mast arm. Other hardware and components may also be included.

The Contractor shall be responsible for the condition of the traffic signal equipment from the time Contractor takes maintenance of the signal installation until the acceptance of the equipment by LCDOT, and again from the time the equipment is returned by LCDOT to the Contractor for reinstallation until the time that LCDOT accepts maintenance of the traffic signal installation. If the equipment is damaged while in the Contractor's possession or for any reason is found to be in unacceptable condition by the LCDOT, then the Contractor shall be responsible for providing new equipment that is approved by LCDOT at no additional cost to the contract.

The Adaptive Control System shall be installed and configured for simultaneous operation of the adaptive equipment as well as the proposed traffic signal equipment at the intersection. All necessary connectors, Ethernet repeaters, camera mounting hardware, wiring, materials, project related fees and labor to achieve proper operation of the Adaptive Control System shall be included in this pay item.

The County reserves the right to request a representative of the equipment supplier and/or vendor to be present during the installation and/or activation of the Adaptive Signal Control equipment. Any costs associated with equipment supplier and/or vendor representation shall be included in the unit price of this pay item. Any unforeseen costs incurred by the Contractor to provide this representation shall not be the responsibility of the County.

Removal: The existing Adaptive Control System and all associated equipment shall be removed by the Contractor and shall be returned to LCDOT for storage in accordance with the special provision REMOVE EXISTING TRAFFIC SIGNAL EQUIPMENT (LCDOT) contained herein.

Installation: When the new traffic signal installation has been constructed, the Contractor shall contact LCDOT to arrange for pick up of the Adaptive Video Detection Cameras and all associated equipment for installation on the new traffic signal.

Installation of the Adaptive Control System hardware and related components shall be completed without the use of any splices to existing or proposed cables. All required cable connections shall be achieved through the use of terminal blocks and shall be installed according to Section 1066 of the Standard Specifications.

The Adaptive video detection camera locations indicated on the plans are approximate and shall be installed according to vendor recommendations. Mounting hardware shall be installed according to vendor recommendations.

The repeater equipment shall be installed in the access panel of the mast arm where the camera is located as shown on the plans, or as directed by the Engineer.

The installation requirements for the InSync Adaptive Control System are detailed in the InSync® Installation and Maintenance Guide (Installation Guide). The Contractor shall install the system hardware and accessory components described according to the procedures and requirements detailed in the Installation Guide, and as directed by the Engineer.

Basis of Payment: This work shall be paid for at the contract unit price per each for RELOCATE EXISTING ADAPTIVE CONTROL SYSTEM which price shall be payment in full for removing the existing Adaptive Control System and all associated equipment, returning it to LCDOT, picking the equipment up from LCDOT and reinstalling it onto the new traffic signal installation. The pay item also includes furnishing and/or installing all necessary connectors, hardware, wiring, materials and all labor required to achieve proper operation of the Adaptive Control System to the satisfaction of LCDOT and the Engineer. Any additional related fees charged by others, if applicable, shall also be included in this pay item.

GENERAL ELECTRICAL REQUIREMENTS

This special provision replaces Articles 801.01 – 801.07, 801.09 – 801-16 of the Standard Specifications.

Definition. Codes, standards, and industry specifications cited for electrical work shall be by definition the latest adopted version thereof, unless indicated otherwise.

Materials by definition shall include electrical equipment, fittings, devices, motors, appliances, fixtures, apparatus, all hardware and appurtenances, and the like, used as part of, or in connection with, electrical installation.

Standards of Installation. Materials shall be installed according to the manufacturer's recommendations, the NEC, OSHA, the NESC, and AASHTO's Standard Specifications for Structural Supports for Highway Signs, Luminaires, and Traffic Signals.

All like materials shall be from the same manufacturer. Listed and labeled materials shall be used whenever possible. The listing shall be according to UL or an approved equivalent.

Safety and Protection. Safety and protection requirements shall be as follows.

Safety. Electrical systems shall not be left in an exposed or otherwise hazardous condition. All electrical boxes, cabinets, pole handholes, etc. which contain wiring, either energized or non-energized, shall be closed or shall have covers in place and be locked when possible, during nonworking hours.

Protection. Electrical raceway or duct openings shall be capped or otherwise sealed from the entrance of water and dirt. Wiring shall be protected from mechanical injury.

Equipment Grounding Conductor. All electrical systems, materials, and appurtenances shall be grounded. Good ground continuity throughout the electrical system shall be assured, even though every detail of the requirements is not specified or shown. Electrical circuits shall have a continuous insulated equipment grounding conductor. When metallic conduit is used, it shall be bonded to the equipment grounding conductor, but shall not be used as the equipment grounding conductor.

Detector loop lead-in circuits, circuits under 50 volts, and runs of fiber optic cable will not require an equipment grounding conductor.

Where connections are made to painted surfaces, the paint shall be scraped to fully expose metal at the connection point. After the connection is completed, the paint system shall be repaired to the satisfaction of the Engineer.

Bonding of all boxes and other metallic enclosures throughout the wiring system to the equipment grounding conductor shall be made using a splice and pigtail connection. Mechanical connectors shall have a serrated washer at the contact surface.

All connections to structural steel or fencing shall be made with exothermic welds. Care shall be taken not to weaken load carrying members. Where connections are made to epoxy coated reinforcing steel, the epoxy coating shall be sufficiently removed to facilitate a mechanical connection. The epoxy coating shall be repaired to the satisfaction of the Engineer. Where connections are made to insulated conductors, the connection shall be wrapped with at least four layers of electrical tape extended 6 in. (150 mm) onto the conductor insulation.

Submittals. At the preconstruction meeting, the Contractor shall submit a written listing of manufacturers for all major electrical and mechanical items. The list of manufacturers shall be binding, except by written request from the Contractor and approval by the Engineer. The request shall include acceptable reasons and documentation for the change.

Major items shall include, but not limited to the following:

Type of Work (discipline)	Item
All Electrical Work	Electric Service Metering Emergency Standby System Transformers Cable Unit Duct Splices Conduit Surge Suppression System
Lighting	Tower Pole Luminaire Foundation Breakaway Device Controllers Control Cabinet and Peripherals
ITS	Controller Cabinet and Peripherals CCTV Cameras Camera Structures Ethernet Switches Detectors Detector Loop Fiber Optic Cable

Within 30 calendar days after contract execution, the Contractor shall submit, for approval, one copy each of the manufacturer's product data (for standard products and components) and detailed shop drawings (for fabricated items). Submittals for the materials for each individual pay item shall be complete in every respect. Submittals which include multiple pay items shall have all submittal material for each item or group of items covered by a particular specification, grouped together and the applicable pay item identified. Various submittals shall, when taken together, form a complete coordinated package. A partial submittal will be returned without review unless prior written permission is obtained from the Engineer.

The submittal shall be properly identified by route, section, county, and contract number.

The Contractor shall have reviewed the submittal material and affixed his/her stamp of approval, with date and signature, for each individual item. In case of subcontractor submittal, both the subcontractor and the Contractor shall review, sign, and stamp their approval on the submittal.

Illegible print, incompleteness, inaccuracy, or lack of coordination will be grounds for rejection.

Items from multiple disciplines shall not be combined on a single submittal and transmittal. Items for lighting, signals, surveillance and CCTV must be in separate submittals since they may be reviewed by various personnel in various locations.

The Engineer will review the submittals for conformance with the design concept of the project according to Article 105.04 and the following. The Engineer will stamp the drawings indicating their status as "Approved", "Approved as Noted", "Disapproved", or "Information Only". Since the Engineer's review is for conformance with the design concept only, it shall be the Contractor's responsibility to coordinate the various items into a working system as specified. The Contractor shall not be relieved from responsibility for errors or omissions in the shop, working, or layout drawings by the Engineer's approval thereof. The Contractor shall still be in full compliance with contract and specification requirements.

All submitted items reviewed and marked "Disapproved" or "Approved as Noted" shall be resubmitted by the Contractor in their entirety, unless otherwise indicated within the submittal comments.

Work shall not begin until the Engineer has approved the submittal. Material installed prior to approval by the Engineer, will be subject to removal and replacement at no additional cost to the Department.

Unless otherwise approved by the Engineer, all of the above items shall be submitted to the Engineer at the same time. Each item shall be properly identified by route, section, and contract number.

Certifications. When certifications are specified and are available prior to material manufacture, the certification shall be included in the submittal information. When specified and

only available after manufacture, the submittal shall include a statement of intent to furnish certification. All certificates shall be complete with all appropriate test dates and data.

Authorized Project Delay. See Article 801.08

Maintenance transfer and Preconstruction Inspection:

General. Before performing any excavation, removal, or installation work (electrical or otherwise) at the site, the Contractor shall request a maintenance transfer and preconstruction site inspection, to be held in the presence of the Engineer and a representative of the party or parties responsible for maintenance of any lighting and/or traffic control systems which may be affected by the work. The request for the maintenance transfer and preconstruction inspection shall be made no less than seven (7) calendar days prior to the desired inspection date. The maintenance transfer and preconstruction inspection shall:

Establish the procedures for formal transfer of maintenance responsibility required for the construction period.

Establish the approximate location and operating condition of lighting and/or traffic control systems which may be affected by the work

Marking of Existing Cable Systems. The party responsible for maintenance of any existing lighting and/or traffic control systems at the project site will, at the Contractor's request, mark and/or stake, once per location, all underground cable routes owned or maintained by the Village. A project may involve multiple "locations" where separated electrical systems are involved (i.e. different controllers). The markings shall be taken to have a horizontal tolerance of at least 304.8 mm (one (1) foot) to either side.. The request for the cable locations and marking shall be made at the same time the request for the maintenance transfer and preconstruction inspection is made. The Contractor shall exercise extreme caution where existing buried cable runs are involved. The markings of existing systems are made strictly for assistance to the Contractor and this does not relieve the Contractor of responsibility for the repair or replacement of any cable run damaged in the course of his work, as specified elsewhere herein. Note that the contractor shall be entitled to only one request for location marking of existing systems and that multiple requests may only be honored at the contractor's expense. No locates will be made after maintenance is transferred, unless it is at the contractor's expense.

Condition of Existing Systems. The Contractor shall conduct an inventory of all existing electrical system equipment within the project limits, which may be affected by the work, making note of any parts which are found broken or missing, defective or malfunctioning. Megger and load readings shall be taken for all existing circuits which will remain in place or be modified. If a circuit is to be taken out in its entirety, then readings do not have to be taken. The inventory and test data shall be reviewed with and approved by the Engineer and a record of the inventory shall be submitted to the Engineer for the record. Without such a record, all systems transferred to the Contractor for maintenance during construction shall be returned at the end of construction in complete, fully operating condition.”

Marking Proposed Locations for Highway Lighting System. The Contractor shall mark or stake the proposed locations of all poles, cabinets, junction boxes, pull boxes, handholes, cable routes, pavement crossings, and other items pertinent to the work. A proposed location inspection by the Engineer shall be requested prior to any excavation, construction, or installation work after all proposed installation locations are marked. Any work installed without location approval is subject to corrective action at no additional cost to the Department.

Inspection of electrical work. Inspection of electrical work shall be according to Article 105.12 and the following.

Before any splice, tap, or electrical connection is covered in handholes, junction boxes, light poles, or other enclosures, the Contractor shall notify and make available such wiring for the Engineer's inspection.

Maintenance and Responsibility During Construction.

Lighting Operation and Maintenance Responsibility. The scope of work shall include the assumption of responsibility for the continuing operation and maintenance of the existing, proposed, temporary, sign and navigation lighting, or other lighting systems and all appurtenances affected by the work as specified elsewhere herein. Maintenance of lighting systems is specified elsewhere and will be paid for separately

The proposed lighting system must be operational prior to opening the roadway to traffic unless temporary lighting exists which is designed and installed to properly illuminate the roadway.

Energy and Demand Charges. The payment of basic energy and demand charges by the electric utility for existing lighting which remains in service will continue as a responsibility of the Owner, unless otherwise indicated. Unless otherwise indicated or required by the Engineer duplicate lighting systems (such as temporary lighting and proposed new lighting) shall not be operated simultaneously at the Owner's expense and lighting systems shall not be kept in operation during long daytime periods at the Owner's expense. Upon written authorization from the Engineer to place a proposed new lighting system in service, whether the system has passed final acceptance or not, (such as to allow temporary lighting to be removed), the Owner will accept responsibility for energy and demand charges for such lighting, effective the date of authorization. All other energy and demand payments to the utility shall be the responsibility of the Contractor until final acceptance.

Damage to Electrical Systems. Should damage occur to any existing electrical systems through the Contractor's operations, the Engineer will designate the repairs as emergency or non-emergency in nature.

Emergency repairs shall be made by the Contractor, or as determined by the Engineer, the Department, or its agent. Non-emergency repairs shall be performed by the Contractor within six working days following discovery or notification. All repairs shall be performed in an

expeditious manner to assure all electrical systems are operational as soon as possible. The repairs shall be performed at no additional cost to the Department.

Lighting. An outage will be considered an emergency when three or more lights on a circuit or three successive lights are not operational. Knocked down materials, which result in a danger to the motoring public, will be considered an emergency repair.

Temporary aerial multi-conductor cable, with grounded messenger cable, will be permitted if it does not interfere with traffic or other operations, and if the Engineer determines it does not require unacceptable modification to existing installations.

Testing. Before final inspection, the electrical work shall be tested. Tests may be made progressively as parts of the work are completed, or may be made when the work is complete. Tests shall be made in the presence of the Engineer. Items which fail to test satisfactorily shall be repaired or replaced. Tests shall include checks of control operation, system voltages, cable insulation, and ground resistance and continuity.

The forms for recording test readings will be available from the Engineer in electronic format. The Contractor shall provide the Engineer with a written report of all test data including the following:

- Voltage Tests
- Amperage Tests
- Insulation Resistance Tests
- Continuity tests
- Detector Loop Tests

Lighting systems. The following tests shall be made.

- (1) Voltage Measurements. Voltages in the cabinet from phase to phase and phase to neutral, at no load and at full load, shall be measured and recorded. Voltage readings at the last termination of each circuit shall be measured and recorded.
- (2) Insulation Resistance. Insulation resistance to ground of each circuit at the cabinet, with all loads connected, shall be measured and recorded.

On tests of new cable runs, the readings shall exceed 50 megohms for phase and neutral conductors with a connected load over 20 A, and shall exceed 100 megohms for conductors with a connected load of 20 A or less.

On tests of cable runs which include cables which were existing in service prior to this contract, the resistance readings shall be the same or better than the readings recorded at the maintenance transfer at the beginning of the contract. Measurements shall be taken with a megohm meter approved by the Engineer.

- (3) Loads. The current of each circuit, phase main, and neutral shall be measured and recorded. The Engineer may direct reasonable circuit rearrangement. The current readings shall be within ten percent of the connected load based on material ratings.
- (4) Ground Continuity. Resistance of the system ground as taken from the farthest extension of each circuit run from the controller (i.e. check of equipment ground continuity for each circuit) shall be measured and recorded. Readings shall not exceed 2.0 ohms, regardless of the length of the circuit.
- (5) Resistance of Grounding Electrodes. Resistance to ground of all grounding electrodes shall be measured and recorded. Measurements shall be made with a ground tester during dry soil conditions as approved by the Engineer. Resistance to ground shall not exceed 10 ohms.

ITS. The following test shall be made in addition to the lighting system test above.

Detector Loops. Before and after permanently securing the loop in the pavement, the resistance, inductance, resistance to ground, and quality factor for each loop and lead-in circuit shall be tested. The loop and lead-in circuit shall have an inductance between 20 and 2500 microhenries. The resistance to ground shall be a minimum of 50 megohms under any conditions of weather or moisture. The quality factor (Q) shall be 5 or greater.

Fiber Optic Systems. Fiber optic testing shall be performed as required in the fiber optic cable special provision and the fiber optic splice special provision.

All test results shall be furnished to the Engineer seven working days before the date the inspection is scheduled.

Contract Guarantee. The Contractor shall provide a written guarantee for all electrical work provided under the contract for a period of six months after the date of acceptance with the following warranties and guarantees.

- (a) The manufacturer's standard written warranty for each piece of electrical material or apparatus furnished under the contract. The warranty for light emitting diode (LED) modules, including the maintained minimum luminance, shall cover a minimum of 60 months from the date of delivery.
- (b) The Contractor's written guarantee that, for a period of six months after the date of final acceptance of the work, all necessary repairs to or replacement of said warranted material or apparatus for reasons not proven to have been caused by negligence on the part of the user or acts of a third party shall be made by the Contractor at no additional cost to the Department.

- (c) The Contractor's written guarantee for satisfactory operation of all electrical systems furnished and constructed under the contract for a period of six months after final acceptance of the work.

The warranty for an uninterruptable power supply (UPS) shall cover a minimum of two years from date the equipment is placed in operation; however, the batteries of the UPS shall be warranted for full replacement for a minimum of five years.

Record Drawings. Alterations and additions to the electrical installation made during the execution of the work shall be neatly and plainly marked in red by the Contractor on the full-size set of record drawings kept at the Engineer's field office for the project. These drawings shall be updated on a daily basis and shall be available for inspection by the Engineer during the course of the work. The record drawings shall include the following:

- Cover Sheet
- Summary of Quantities, electrical items only
- Legends, Schedules and Notes
- Plan Sheet
- Pertinent Details
- Single Line Diagram
- Other useful information useful to locate and maintain the systems.

Any modifications to the details shall be indicated. Final quantities used shall be indicated on the Summary of Quantities. Foundation depths used shall also be listed.

As part of the record drawings, the Contractor shall inventory all materials, new or existing, on the project and record information on inventory sheets provided by the Engineer.

The inventory shall include:

- Location of Equipment, including rack, chassis, slot as applicable.
- Designation of Equipment
- Equipment manufacturer
- Equipment model number
- Equipment Version Number
- Equipment Configuration
 - Addressing, IP or other
 - Settings, hardware or programmed
- Equipment Serial Number

The following electronic inventory forms are available from the Engineer:

- Lighting Controller Inventory
- Lighting Inventory
- Light Tower Inspection Checklist

- ITS Location Inventory

The information shall be entered in the forms; handwritten entries will not be acceptable; except for signatures. Electronic file shall also be included in the documentation.

When the work is complete, and seven days before the request for a final inspection, the set of contract drawings, stamped “**RECORD DRAWINGS**”, shall be submitted to the Engineer for review and approval and shall be stamped with the date and the signature of the Contractor’s supervising Engineer or electrician. The record drawings shall be submitted in PDF format on CDROM as well as hardcopy’s for review and approval.

In addition to the record drawings, PDF copies of the final catalog cuts which have been Approved and Approved as Noted with applicable follow-up shall be submitted along with the record drawings. The PDF files shall clearly indicate either by filename or PDF table of contents the respective pay item number. Specific part or model numbers of items which have been selected shall be clearly visible. Hard copies of the catalog are not required with this submittal.

The Contractor shall provide two sets of electronically produced drawings in a moisture proof pouch to be kept on the inside door of the controller cabinet or other location approved by the Engineer. These drawings shall show the final as-built circuit orientation(s) of the project in the form of a single line diagram with all luminaires numbered and clearly identified for each circuit.

Final documentation shall be submitted as a complete submittal package, i.e. record drawings, test results, inventory, etc. shall be submitted at the same time. Partial piecemeal submittals will be rejected without review. A total of five hardcopies and CDROMs of the final documentation shall be submitted.

GPS Documentation. In addition to the specified record drawings, the Contactor shall record GPS coordinates of the following electrical components being installed, modified or being affected in other ways by this contract:

- All light poles and light towers.
- Handholes and vaults.
- Junction Boxes
- Conduit roadway crossings.
- Controllers.
- Control Buildings.
- Structures with electrical connections, i.e. DMS, lighted signs.
- Electric Service locations.
- CCTV Camera installations.
- Roadway Surveillance installations.
- Fiber Optic Splice Locations.
- Fiber Optic Cables. Coordinates shall be recorded along each fiber optic cable route every 200 feet.

- All fiber optic slack locations shall be identified with quantity of slack cable included. When sequential cable markings are available, those markings shall be documented as cable marking into enclosure and marking out of enclosure.

Datum to be used shall be North American 1983.

Data shall be provided electronically and in print form. The electronic format shall be compatible with MS Excel. Latitude and Longitude shall be in decimal degrees with a minimum of 6 decimal places. Each coordinate shall have the following information:

1. District
2. Description of item
3. Designation
4. Use
5. Approximate station
6. Contract Number
7. Date
8. Owner
9. Latitude
10. Longitude
11. Comments

A spreadsheet template will be available from the Engineer for use by the Contractor.

Prior to the collection of data, the contractor shall provide a sample data collection of at least six data points of known locations to be reviewed and verified by the Engineer to be accurate within 20 feet. Upon verification, data collection can begin. Data collection can be made as construction progresses, or can be collected after all items are installed. If the data is unacceptable the contractor shall make corrections to the data collection equipment and or process and submit the data for review and approval as specified. **Data collection prior to the submittal and review of the sample data of existing data points will be unacceptable and rejected.**

Accuracy. Data collected is to be mapping grade. A handheld mapping grade GPS device shall be used for the data collection. The receiver shall support differential correction and data shall have minimum 5 meter accuracy after post processing.

GPS receivers integrated into cellular communication devices, recreational and automotive GPS devices are not acceptable.

The GPS shall be the product of an established major GPS manufacturer having been in the business for a minimum of 6 years.”

The documents on the CD shall be organized by the Electrical Maintenance Contract Management System (EMCMS) location designation. If multiple EMCMS locations are within the contract, separate folders shall be utilized for each location as follows:

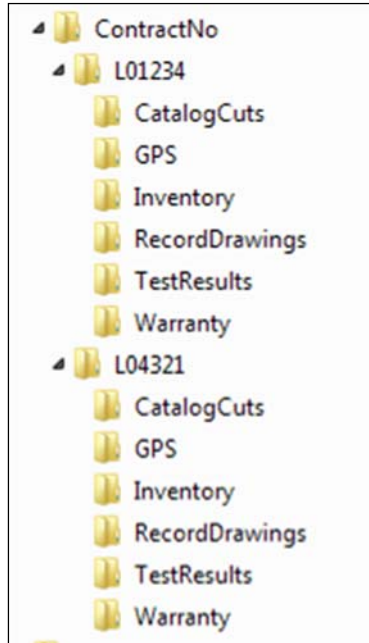

Extraneous information not pertaining to the specific EMCMS location shall not be included in that particular folder and sub-folder.

The inspection will not be made until after the delivery of acceptable record drawings, specified certifications, and the required guarantees.

The Final Acceptance Documentation Checklist shall be completed and is contained elsewhere herein.

All CD's shall be labeled as illustrated in the CD Label Template contained herein.

Acceptance. Acceptance of electrical work will be given at the time when the Village of Buffalo Grove assumes the responsibility to protect and maintain the work according to Article 107.30 or at the time of final inspection.

When the electrical work is complete, tested, and fully operational, the Contractor shall schedule an inspection for acceptance with the Engineer no less than seven working days prior to the desired inspection date. The Contractor shall furnish the necessary labor and equipment to make the inspection.

A written record of the test readings taken by the Contractor according to Article 801.13 shall be furnished to the Engineer seven working days before the date the inspection is scheduled.

Inspection will not be made until after the delivery of acceptable record drawings, specified certifications, and the required guarantees.

Final Acceptance Documentation Checklist

LOCATION	
Route	Common Name
Limits	Section
Contract #	County
Controller Designation(s)	EMC Database Location Number(s)

ITEM	Contractor (Verify)	Resident Engineer (Verify)
Record Drawings -Four hardcopies (11" x 17") -Scanned to two CD-ROMs	<input type="checkbox"/> <input type="checkbox"/>	<input type="checkbox"/> <input type="checkbox"/>
Field Inspection Tests -Voltage -Amperage -Cable Insulation Resistance -Continuity -Controller Ground Rod Resistance (Four Hardcopies & scanned to two CD's)	<input type="checkbox"/> <input type="checkbox"/> <input type="checkbox"/> <input type="checkbox"/> <input type="checkbox"/>	<input type="checkbox"/> <input type="checkbox"/> <input type="checkbox"/> <input type="checkbox"/> <input type="checkbox"/>
GPS Coordinates -Excel file (Check Special Provisions, Excel file scanned to two CD's)	<input type="checkbox"/>	<input type="checkbox"/>
Job Warranty Letter (Four Hardcopies & scanned to two CD's)	<input type="checkbox"/>	<input type="checkbox"/>
Catalog Cut Submittals -Approved & Approved as Noted (Scanned to two CD's)	<input type="checkbox"/>	<input type="checkbox"/>
Lighting Inventory Form (Four Hardcopies & scanned to two CD's)	<input type="checkbox"/>	<input type="checkbox"/>
Lighting Controller Inventory Form (Four Hardcopies & scanned to two CD's)	<input type="checkbox"/>	<input type="checkbox"/>
Light Tower Inspection Form (If applicable, Four Hardcopies & scanned to two CD's)	<input type="checkbox"/>	<input type="checkbox"/>

Four Hardcopies & scanned to two CD's shall be submitted for all items above. The CD ROM shall be labeled as shown in the example contained herein.

General Notes:

Record Drawings – The record drawings should contain contract cover sheet, summary of quantities showing all lighting pay item sheets, proposed lighting plans and lighting detail sheets. Submit hardcopies 11 x 17 size. Include the original “red-ink” copy. The red-ink markup should be neatly drawn. Record drawings copies should be legible. Blurred copies will not be acceptable. Temporary lighting plans and removal lighting plans should not be part of the set.

Field Inspection Tests – Testing should be done for proposed cables. Testing shall be per standard specifications. Forms shall be neatly filled out.

GPS Coordinates – Check special provisions “General Electrical Requirements”. Submit electronic “EXCEL” file.

Job Warranty Letter – See standard specifications.

Cutsheet Submittal – See special provisions “General Electrical Requirements”. Scan Approved and Approved as Noted cutsheets.

Lighting Inventory Form – Inventory form should include only proposed light poles, proposed light towers, proposed combination (traffic/light pole) lighting and proposed underpass luminaires.

Lighting Controller Inventory Form – Form should be filled out for only proposed lighting controllers.

Light Tower Safety Inspection Form – Form should be filled out for each proposed light tower.

CD LABEL FORMAT TEMPLATE.

Label must be printed; hand written labels are unacceptable and will be rejected.

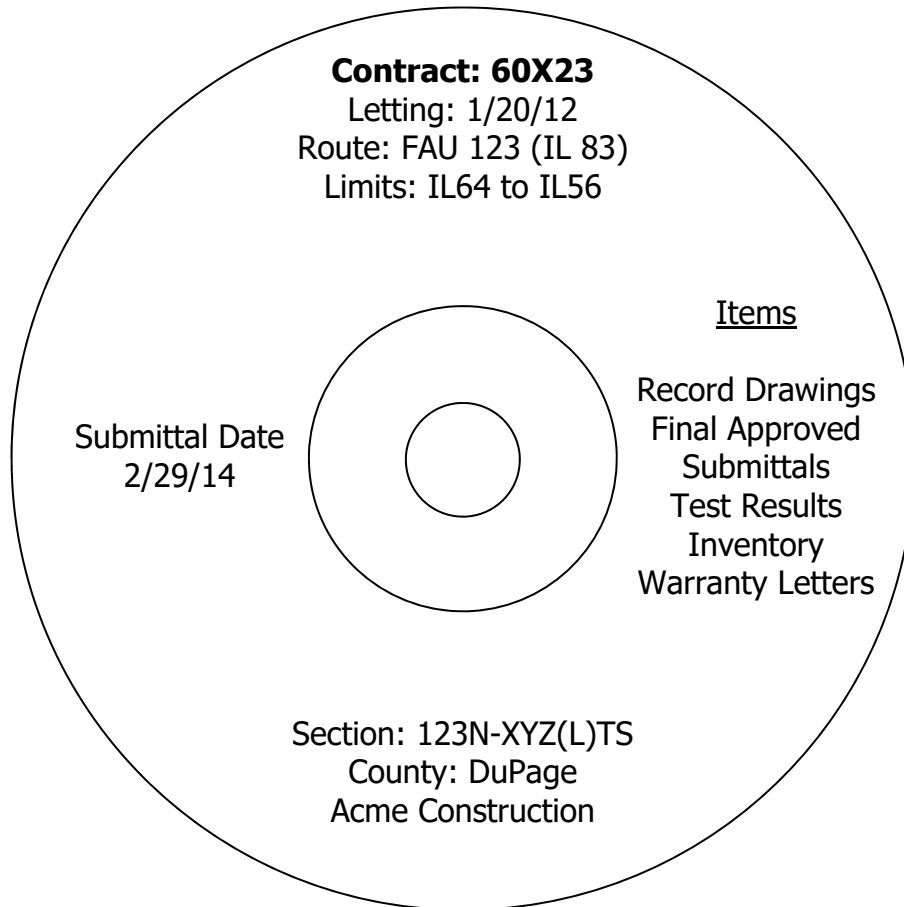

ELECTRIC SERVICE INSTALLATION

Effective: January 1, 2012

Description. This item shall consist of all material and labor required to extend, connect or modify the electric services, as indicated or specified, which is over and above the work performed by the utility. Unless otherwise indicated, the cost for the utility work, if any, will be reimbursed to the Contractor separately under ELECTRIC UTILITY SERVICE CONNECTION. This item may apply to the work at more than one service location and each will be paid separately.

Materials. Materials shall be in accordance with the Standard Specifications.

CONSTRUCTION REQUIREMENTS

General. The Contractor shall ascertain the work being provided by the electric utility and shall provide all additional material and work not included by other contract pay items required to complete the electric service work in complete compliance with the requirements of the utility.

No additional compensation will be allowed for work required for the electric service, even though not explicitly shown on the Drawings or specified herein

Method of Measurement. Electric Service Installation shall be counted, each.

Basis of Payment. This work will be paid for at the contract unit price each for ELECTRIC SERVICE INSTALLATION which shall be payment in full for the work specified herein.

ELECTRIC UTILITY SERVICE CONNECTION (COMED)

Effective: January 1, 2012

Description. This item shall consist of payment for work performed by ComEd in providing or modifying electric service as indicated. THIS MAY INVOLVE WORK AT MORE THAN ONE ELECTRIC SERVICE. For summary of the Electrical Service Drop Locations see the schedule contained elsewhere herein.

CONSTRUCTION REQUIREMENTS

General. It shall be the Contractor's responsibility to contact ComEd. The Contractor shall coordinate his work fully with the ComEd both as to the work required and the timing of the installation. No additional compensation will be granted under this or any other item for extra work caused by failure to meet this requirement. Please contact ComEd, New Business Center Call Center, at 866 NEW ELECTRIC (1-866-639-3532) to begin the service connection process. The Call Center Representatives will create a work order for the service connection. The representative will ask the requestor for information specific to the request. The representative will assign the request based upon the location of project.

The Contractor should make particular note of the need for the earliest attention to arrangements with ComEd for service. In the event of delay by ComEd, no extension of time will be considered applicable for the delay unless the Contractor can produce written evidence of a request for electric service within 30 days of execution.

Method of Payment. The Contractor will be reimbursed to the exact amount of money as billed by ComEd for its services. Work provided by the Contractor for electric service will be paid separately as described under ELECTRIC SERVICE INSTALLATION. No extra compensation shall be paid to the Contractor for any incidental materials and labor required to fulfill the requirements as shown on the plans and specified herein.

For bidding purposes, this item shall be estimated as \$5,000

Basis of Payment. This work will be paid for at the contract lump sum price for ELECTRIC UTILITY SERVICE CONNECTION which shall be reimbursement in full for electric utility service charges.

UNDERGROUND RACEWAYS

Effective: March 1, 2015

Revise Article 810.04 of the Standard Specifications to read:

“Installation. All underground conduits shall have a minimum depth of 30-inches (700 mm) below the finished grade.”

Add the following to Article 810.04 of the Standard Specifications:

“All metal conduit installed underground shall be Rigid Steel Conduit unless otherwise indicated on the plans.”

Add the following to Article 810.04 of the Standard Specifications:

“All raceways which extend outside of a structure or duct bank but are not terminated in a cabinet, junction box, pull box, handhole, post, pole, or pedestal shall extend a minimum of 300 mm (12”) or the length shown on the plans beyond the structure or duct bank. The end of this extension shall be capped and sealed with a cap designed for the conduit to be capped.

The ends of rigid metal conduit to be capped shall be threaded, the threads protected with full galvanizing, and capped with a threaded galvanized steel cap.

The ends of rigid nonmetallic conduit and coilable nonmetallic conduit shall be capped with a rigid PVC cap of not less than 3 mm (0.125”) thick. The cap shall be sealed to the conduit using a room-temperature-vulcanizing (RTV) sealant compatible with the material of both the cap and the conduit. A washer or similar metal ring shall be glued to the inside center of the cap with epoxy, and the pull cord shall be tied to this ring.”

UNIT DUCT

Effective: January 1, 2012

Revise the first paragraph of Article 810.04 to read:

“The unit duct shall be installed at a minimum depth of 30-inches (760 mm) unless otherwise directed by the Engineer.”

Revise Article 1088.01(c) to read:

“(c) Coilable Nonmetallic Conduit.

General:

The duct shall be a plastic duct which is intended for underground use and which can be manufactured and coiled or reeled in continuous transportable lengths and uncoiled for further processing and/or installation without adversely affecting its properties of performance. The duct shall be a plastic duct which is intended for underground use and can be manufactured and coiled or reeled in continuous transportable lengths and uncoiled for further processing and/or installation without adversely affecting its properties of performance.

The duct shall be made of high density polyethylene which shall meet the requirements of ASTM D 2447, for schedule 40. The duct shall be composed of black high density polyethylene meeting the requirements of ASTM D 3350, Class C, Grade P33. The wall thickness shall be in accordance with Table 2 for ASTM D 2447.

The duct shall be UL Listed per 651-B for continuous length HDPE coiled conduit. The duct shall also comply with NEC Article 354.100 and 354.120.

Submittal information shall demonstrate compliance with the details of these requirements.

Dimensions:

Duct dimensions shall conform to the standards listed in ASTM D2447. Submittal information shall demonstrate compliance with these requirements.

Nominal Size		Nominal I.D.		Nominal O.D.		Minimum Wall	
mm	in	mm	in	mm	in	mm	in
31.75	1.25	35.05	1.380	42.16	1.660	3.556 +0.51	0.140 +0.020
38.1	1.50	40.89	1.610	48.26	1.900	3.683 +0.51	0.145 +0.020

Nominal Size		Pulled Tensile	
mm	in	N	lbs
31.75	1.25	3322	747
38.1	1.50	3972	893

Marking:

As specified in NEMA Standard Publication No. TC-7, the duct shall be clearly and durably marked at least every 3.05 meters (10 feet) with the material designation (HDPE for high density polyethylene), nominal size of the duct and the name and/or trademark of the manufacturer.

Performance Tests:

Polyethylene Duct testing procedures and test results shall meet the requirements of UL 651. Certified copies of the test report shall be submitted to the Engineer prior to the installation of the duct. Duct crush test results shall meet or exceed the following requirements:

Duct Diameter		Min. force required to deform sample 50%	
mm	in	N	lbs
35	1.25	4937	1110
41	1.5	4559	1025

WIRE AND CABLE

Effective: January 1, 2012

Add the following to the first paragraph of Article 1066.02(a):

“The cable shall be rated at a minimum of 90°C dry and 75°C wet and shall be suitable for installation in wet and dry locations, and shall be resistant to oils and chemicals.”

Revise the Aerial Electric Cable Properties table of Article 1066.03(a)(3) to read:

Aerial Electric Cable Properties

Phase Conductor		Messenger wire			
Size AWG	Stranding	Average Insulation Thickness		Minimum Size AWG	Stranding
		mm	mils		
6	7	1.1	(45)	6	6/1
4	7	1.1	(45)	4	6/1
2	7	1.1	(45)	2	6/1
1/0	19	1.5	(60)	1/0	6/1
2/0	19	1.5	(60)	2/0	6/1
3/0	19	1.5	(60)	3/0	6/1
4/0	19	1.5	(60)	4/0	6/1

Add the following to Article 1066.03(b) of the Standard Specifications:

“Cable sized No. 2 AWG and smaller shall be U.L. listed Type RHH/RHW and may be Type RHH/RHW/USE. Cable sized larger than No. 2 AWG shall be U.L. listed Type RHH/RHW/USE.”

Revise Article 1066.04 to read:

“Aerial Cable Assembly. The aerial cable shall be an assembly of insulated aluminum conductors according to Section 1066.02 and 1066.03. Unless otherwise indicated, the cable assembly shall be composed of three insulated conductors and a steel reinforced bare aluminum conductor (ACSR) to be used as the ground conductor. Unless otherwise indicated, the code word designation of this cable assembly is “Palomino”. The steel reinforced aluminum conductor shall conform to ASTM B-232. The cable shall be assembled according to ANSI/ICEA S-76-474.”

Revise the second paragraph of Article 1066.05 to read:

“The tape shall have reinforced metallic detection capabilities consisting of a woven reinforced polyethylene tape with a metallic core or backing.”

MAINTENANCE OF LIGHTING SYSTEMS

Replace Article 801.11 and 801.12 of the Standard Specifications with the following:

Effective the date the Contractor's activities (electrical or otherwise) at the job site begin, the Contractor shall be responsible for the proper operation and maintenance of all existing and proposed lighting systems which are part of, or which may be affected by the work until final acceptance or as otherwise determined by the Engineer.

Before performing any excavation, removal, or installation work (electrical or otherwise) at the site, the Contractor shall initiate a request for a maintenance transfer and preconstruction inspection, as specified elsewhere herein, to be held in the presence of the Engineer and a representative of the party or parties responsible for maintenance of any lighting systems which may be affected by the work. During the maintenance preconstruction inspection, the party responsible for existing maintenance shall perform testing of the existing system in accordance with Article 801.13a. The Contractor shall request a date for the preconstruction inspection no less than fourteen (14) days prior to the desired date of the inspection.

The Engineer will document all test results and note deficiencies. All substandard equipment will be repaired or replaced by the existing maintenance contractor, or the Engineer can direct the Contractor to make the necessary repairs under Section 109.04.

Existing lighting systems, when depicted on the plans, are intended only to indicate the general equipment installation of the systems involved and shall not be construed as an exact representation of the field conditions. It remains the Contractor's responsibility to visit the site to confirm and ascertain the exact condition of the electrical equipment and systems to be maintained. Contract documents shall indicate the circuit limits.

Maintenance of Existing Lighting Systems

Existing lighting systems. Existing lighting systems shall be defined as any lighting system or part of a lighting system in service at the time of contract Letting. The contract drawings indicate the general extent of any existing lighting, but whether indicated or not, it remains the Contractor's responsibility to ascertain the extent of effort required for compliance with these specifications and failure to do so will not be justification for extra payment or reduced responsibilities.

Extent of Maintenance.

Partial Maintenance. Unless otherwise indicated, if the number of circuits affected by the contract is equal to or less than 40% of the total number of circuits in a given controller and the controller is not part of the contract work, the Contractor needs only to maintain the affected circuits within the project limits. The project limits are defined as those limits indicated in the contract plans.

Equipment outside of the project limits, on the affected circuits shall be maintained and paid for under Article 109.04. The affected circuits shall be isolated by means of in-line waterproof fuse holders as specified elsewhere and as approved by the Engineer. The unaffected circuits and the controller will remain under the maintenance of the Village.

Full Maintenance. If the number of circuits affected by the contract is greater than 40% of the total number of circuits in a given controller, or if the controller is modified in any way under the contract work, the Contractor shall maintain the entire controller and all associated circuits within the project limits. Equipment outside of the project limits shall be maintained and paid for under Article 109.04.

If the existing equipment is damaged by normal vehicular traffic, not contractor operations, is beyond repair and cannot be re-set, the contractor shall replace the equipment in kind with payment made for such equipment under Article 109.04. If the equipment damaged by any construction operations, not normal vehicular traffic, is beyond repair and cannot be re-set, the contractor shall replace the equipment in kind and the cost of the equipment shall be included in the cost of this pay item and shall not be paid for separately.

Maintenance of Proposed Lighting Systems

Proposed Lighting Systems. Proposed lighting systems shall be defined as any lighting system or part of a lighting system, temporary or permanent, which is to be constructed under this contract regardless of the project limits indicated in the plans.

The Contractor shall be fully responsible for maintenance of all items installed under this contract. Maintenance shall include, but not be limited to, any equipment failures or malfunctions as well as equipment damage either by the motoring public, Contractor operations, vandalism, or other means. The potential cost of replacing or repairing any malfunctioning, damaged, or vandalized equipment shall be included in the bid price of this item and will not be paid for separately.

Lighting System Maintenance Operations

The Contractor's responsibility shall include all applicable responsibilities of the Electrical Maintenance Contract, Village of Buffalo Grove. These responsibilities shall include the maintenance of lighting units (including sign lighting), cable runs and lighting controls. In the case of a pole knockdown or sign light damage, the Contractor shall promptly clear the lighting unit and circuit discontinuity and restore the system to service. The equipment shall then be re-set by the contractor within the time limits specified herein.

If the existing equipment is damaged by normal vehicular traffic, not contractor operations, is beyond repair and cannot be re-set, the contractor shall replace the equipment in kind with payment made for such equipment under Article 109.04. If the equipment damaged by any construction

operations, not normal vehicular traffic, is beyond repair and cannot be re-set, the contractor shall replace the equipment in kind and the cost of the equipment shall be included in the cost of this pay item and shall not be paid for separately.

Responsibilities shall also include weekly night-time patrol of the lighting system, with patrol reports filed immediately with the Engineer and with deficiencies corrected within 24 hours of the patrol. Patrol reports shall be presented on standard forms as designated by the Engineer. Uncorrected deficiencies may be designated by the Engineer as necessitating emergency repairs as described elsewhere herein.

The following chart lists the maximum response, service restoration, and permanent repair time the Contractor will be allowed to perform corrective action on specific lighting system equipment.

INCIDENT OR PROBLEM	SERVICE RESPONSE TIME	SERVICE RESTORATION TIME	PERMANENT REPAIR TIME
Control cabinet out	1 hour	4 hours	7 Calendar days
Hanging mast arm	1 hour to clear	na	7 Calendar days
Radio problem	1 hour	4 hours	7 Calendar days
Motorist caused damage or leaning light pole 10 degrees or more	1 hour to clear	4 hours	7 Calendar days
Circuit out – Needs to reset breaker	1 hour	4 hours	na
Circuit out – Cable trouble	1 hour	24 hours	21 Calendar days
Outage of 3 or more successive lights	1 hour	4 hours	na
Outage of 75% of lights on one tower	1 hour	4 hours	na
Outage of light nearest RR crossing approach, Islands and gores	1 hour	4 hours	na
Outage (single or multiple) found on night outage survey or reported to EMC	na	na	7 Calendar days
Navigation light outage	na	na	24 hours

- **Service Response Time** -- amount of time from the initial notification to the Contractor until a patrolman physically arrives at the location.
- **Service Restoration Time** – amount of time from the initial notification to the Contractor until the time the system is fully operational again (In cases of motorist caused damage the undamaged portions of the system are operational.)
- **Permanent Repair Time** – amount of time from initial notification to the Contractor until the time permanent repairs are made if the Contractor was required to make temporary repairs to meet the service restoration requirement.

Damage caused by the Contractor's operations shall be repaired at no additional cost to the Contract.

Operation of Lighting

The lighting shall be operational every night, dusk to dawn. Duplicate lighting systems (such as temporary lighting and proposed new lighting) shall not be operated simultaneously. Lighting systems shall not be kept in operation during long daytime periods.

Method of Measurement

The contractor shall demonstrate to the satisfaction of the Engineer that the lighting system is fully operational prior to submitting a pay request. Failure to do so will be grounds for denying the pay request. Months in which the lighting systems are not maintained and not operational will not be paid. Payment shall not be made retroactively for months in which lighting systems were not operational.

Basis of Payment. Maintenance of lighting systems shall be paid for at the contract unit price per calendar month for **MAINTENANCE OF LIGHTING SYSTEM.**

LUMINAIRE INSTALLATION

Description. This work shall consist of furnishing and installing LED lighting unit as specified herein.

Materials. The luminaire shall be American Electric Lighting Autobahn Series ATB2 and shall be in compliance with ANSI C136.37. Material for the LED luminaire shall be according to the following.

Type 1 – ATB2 60BLEDE70 MVOLT R3

Type 2 – ATB2 80BLEDE10 MVOLT R3

Optics

- IP66 rated
- Type III light distribution per IESNA classification.

Performance

- Rated for -40°C to 40°C ambient air temperature range
- Color temperature of 4000K
- Fixture wattage of 130 watts or 268 watts

Electronic Drivers

- Performance package for Luminaire Installation, Type 1 is 130 watt luminaire, 60B LED chips with drive current of 700 mA and 17,714 lumens.
- Performance package for Luminaire Installation, Type 2 is 268 watt luminaire, 80B LED chips with drive current of 1000 mA and 32,416 lumens.
- LED light engines are rated > 100,000 hours at 25°C, L70. Electric driver has a rated life of 100,000 hours at a 25°C ambient.
- Minimum of ANSI C136.2 10kV/5kA level of surge protection.

Housing

- Autobahn Series ATB2 is 31” long x 14” wide x 4” high with an approximate weight of 21 lbs.
- Die cast aluminum housing.
- Color: Type 1 is powder coated Dark Bronze (color must be approved with local agencies before purchasing). Type 2 is powder coated Black to match traffic signal poles and mast arms.
- The luminaire shall include a fully prewired, 7 pin twist lock ANSI C136-41 – compliant receptacle. Unused pins shall be connected as directed by the Manufacturer and approved by the Engineer. A shorting cap shall be provided with the luminaire.
- All luminaires shall be vibration tested and pass ANSI C136.31 requirements. Luminaires shall be rated for “3G” peak acceleration. Vibration testing shall be run using the same luminaire in all three axes.

Finish

- Housing is polyester powder-coated for durability and corrosion resistance.
- Rigorous five-stage pre-treating and painting process yields a finish that achieves a scribe creepage rating of 7 (per ASTM D1654) after over 5,000 hours exposure to salt fog chamber (operate per ASTM B117)

Photo-cell

- Shall be mounted on luminaire as specified on the contract plans.

Warranty

- All electrical components warranted for minimum of 5 years

Submittal Requirements. The Contractor shall submit, for approval, an electronic version of all associated luminaire IES files, AGi32 files and the TM-21 or TM-28 calculator spreadsheet with inputs and reports associated with the project luminaires. The Contractor shall also provide (as a minimum) an electronic (PDF) version of each of the following manufacturer's product data for each type of luminaire:

1. Descriptive literature and catalogue cuts for luminaire, LED driver, and surge protection device.
2. LED drive current, total luminaire input wattage and total luminaire current at the system operating voltage or voltage range and ambient temperature of 25 C.
3. LED efficacy per luminaire expressed in lumens per watt (lpw).
4. Initial delivered lumens at the specified color temperature, drive current, and ambient temperature.
5. Computer photometric calculation reports as specified and in the luminaire performance table.
6. TM-15 BUG rating report.
7. Isofootcandle chart with max candela point and half candela trace indicated.
8. Documentation of manufacturers experience and verification that luminaires were assembled in the U.S.A. as specified.
9. Supporting documentation of compliance with ANSI standards as well as UL listing as specified.
10. Supporting documentation of laboratory accreditations and certifications for specified testing as indicated.
11. Thermal testing documents as specified.
12. IESNA LM-79, LM-80 (or LM-84) and TM-21 (or TM-28) reports as specified.
13. Salt fog test reports and certification as specified.
14. Vibration Characteristics Test Reports and certification as specified.

15. Ingress Protection Test Reports as specified.

16. Written warranty.

A sample luminaire shall be provided upon request of the Engineer. The sample shall be as proposed for the contract and shall be delivered to the District Headquarters.

No luminaire testing according to Article 1067.01(h) will be required.

IDOT DISTRICT 1 LUMINAIRE PERFORMANCE TABLE
ROADWAY LIGHTING
Luminaire Installation, Type 1

GIVEN CONDITIONS		
ROADWAY DATA	Pavement Width	79 (ft)
	Number of Lanes	6
	Median Width	none
	I.E.S. Surface Classification	R3
	Q-Zero Value	.07
LIGHT POLE DATA	Mounting Height	35 (ft)
	Mast Arm Length	6 (ft)
	Pole Set-Back From Edge Of Pavement	4.5 (ft)
LUMINAIRE DATA	Lumens	17,714
	BUG Rating	B3 – U0 – G3 (Max)
	I.E.S. Vertical Distribution	Medium
	I.E.S. Lateral Distribution	Type III
	Total Light Loss Factor	0.70
LAYOUT DATA	Spacing	190 (ft)
	Configuration	Opposite
	Luminaire Overhang over EOP	1.5 (ft)

NOTE: Variations from the above specified I.E.S. distribution pattern may be requested and acceptance of variations will be subject to review by the Engineer based on how well the performance requirements are met.

PERFORMANCE REQUIREMENTS		
---------------------------------	--	--

NOTE: These performance requirements shall be the minimum acceptable standards of photometric performance for the luminaire, based on the given conditions listed above.

ROADWAY	Average Luminance, L_{AVE}	Cd/m^2 (Max)
LUMINANCE		0.6 Cd/m^2 (Min)
	Uniformity Ratio, L_{AVE}/L_{MIN}	3.5 (Max)
	Uniformity Ratio, L_{MAX}/L_{MIN}	6.0 (Max)
	Veiling Luminance Ratio, L_V/L_{AVE}	0.4 (Max)

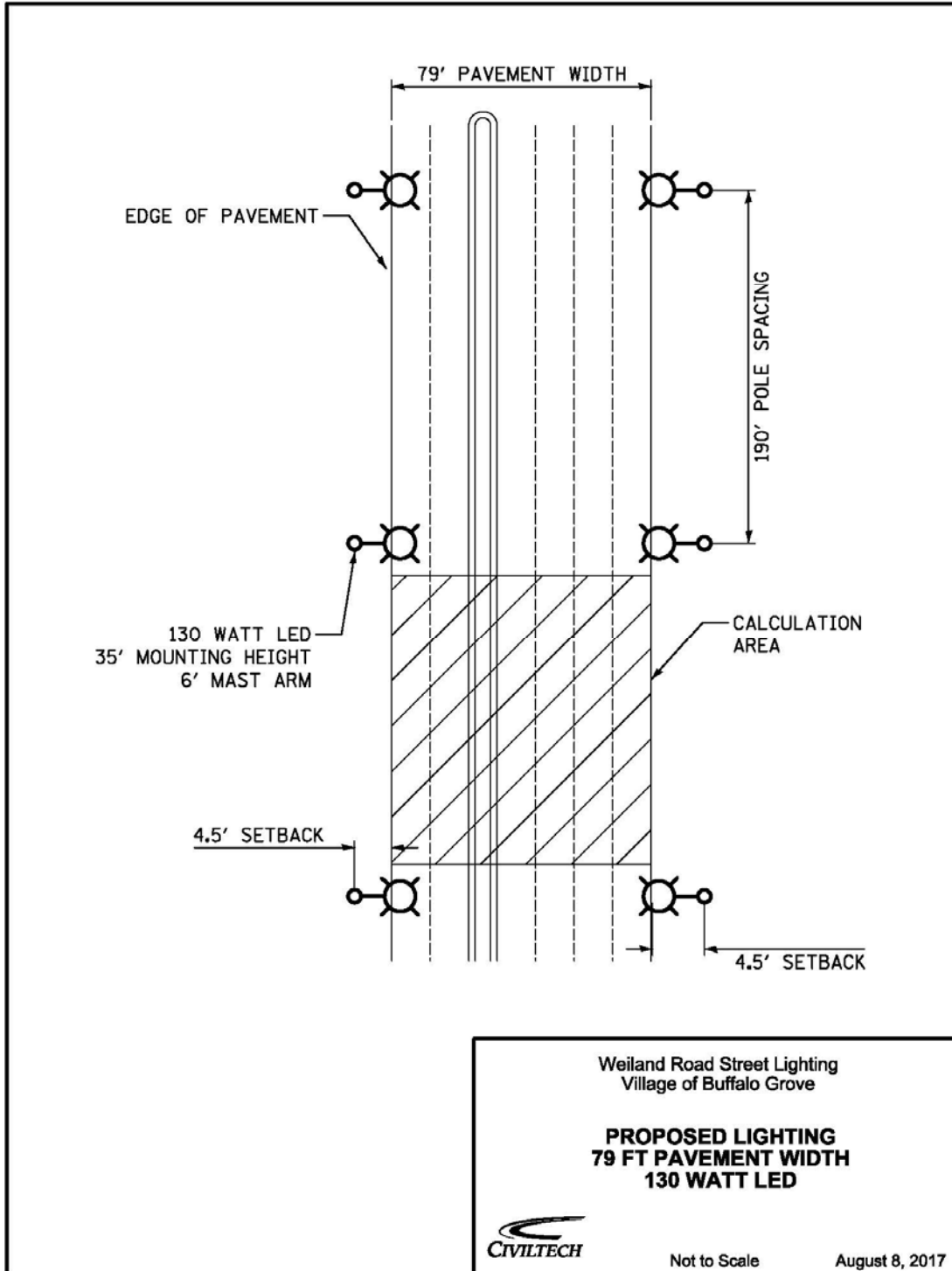

Installation.

Each luminaire shall be installed according to the luminaire manufacturer's recommendations.

Luminaires which are pole mounted shall be mounted on site such that poles and arms are not left unloaded. Pole mounted luminaires shall be leveled/adjusted after poles are set and vertically aligned before being energized. When mounted on a tenon, care shall be exercised to assure maximum insertion of the mounting tenon. Each luminaire shall be checked to assure compatibility with the project power system. When the night-time check of the lighting system by the Engineer indicates that any luminaires are mis-aligned, the mis-aligned luminaires shall be corrected at no additional cost.

No luminaire shall be installed before it is approved. Where independent testing is required, full approval will not be given until complete test results, demonstrating compliance with the specifications, have been reviewed and accepted by the Engineer.

Pole wiring shall be provided with the luminaire. Pole wire shall run from handhole to luminaire.

Pole wire shall be sized No. 10, rated 600 V, RHW/USE-2, and have copper conductors, stranded in conformance with ASTM B 8. Pole wire shall be insulated with cross-linked polyethylene (XLP) insulation. Wire shall be trained within the pole or sign structure so as to avoid abrasion or damage to the insulation.

Pole wire shall be extended through the pole, pole grommet, luminaire ring, and any associated arm and tenon. The pole wire shall be terminated in a manner that avoids sharp kinks, pinching, pressure on the insulation, or any other arrangement prone to damaging insulation value and producing poor megger test results. Wires shall be trained away from heat sources within the luminaire. Wires shall be terminated so all strands are extended to the full depth of the terminal lug with the insulation removed far enough so it abuts against the shoulder of the lug, but is not compressed as the lug is tightened.

Included with the pole wiring shall be fusing located in the handhole. Fusing shall be according to Article 1065.01 and the fuse size as specified by the luminaire manufacturer.

Each luminaire and optical assembly shall be free of all dirt, smudges, etc. Should the optical assembly require cleaning, a luminaire manufacturer approved cleaning procedure shall be used.

Horizontal mount luminaires shall be installed in a level, horizontal plane, with adjustments as needed to insure the optics are set perpendicular to the traveled roadway.

When the pole is bridge mounted, a minimum size stainless steel 1/4-20NC set screw shall be provided to secure the luminaire to the mast arm tenon. A hole shall be drilled and tapped through the tenon and luminaire mounting bracket and then fitted with the screw.

Basis of Payment. This work will be paid for at the contract unit price per each as LUMINAIRE INSTALLATION, TYPE 1; LUMINAIRE INSTALLATION, TYPE 2; as specified in the contract plans which shall include all labor, material and equipment necessary to complete the work as specified.

LUMINAIRE (SPECIAL)

Description. This item shall consist of furnishing and installing LED luminaire as shown in the contract plans, as specified in the LUMINAIRE INSTALLATION specification, and as specified herein.

The luminaire shall be LUMINAIRE INSTALLATION, TYPE 1, as described in the Luminaire Installation specification in this contract. A photocell control will be installed on the luminaire closest to the lighting controller and as specified in the contract plans. 3-1/C No. 10 wires will run from the photocell receptacle to the lighting controller. The wires for the photocell running inside the light pole will not be paid for separately but will be included in the cost of the luminaire. The wire and conduit from the pole to the lighting controller will be paid for separately.

Basis of Payment. This work will be paid for at the contract unit price per each as LUMINAIRE (SPECIAL), as specified in the contract plans which shall include all labor, material and equipment necessary to complete the work as specified.

LIGHT POLE, WEATHERING STEEL, 35 FT. M.H., 6 FT MAST ARM

Description. This item shall consist of furnishing and installing light poles as specified herein, shown on the contract drawings and with Section 830 of the Standard Specification. This item shall include all of the internal wiring, fusing, anchor bolts, and the hardware required for final attachment to the foundation as shown in the drawings.

Material:

The weathering steel light poles are square tapered steel as detailed on the contract drawings.

The pole shall come complete with a 6'-2" mast arm as shown in the plans. Both the pole and the mast arm shall be weathering steel. The pole shaft shall be 7-gauge weathering steel. The pole shall include an internal vibration damper. The pole shaft shall be square in cross section having flat sides, radiused corners and a uniform taper. A handhole shall be provided 1'-6" above the base.

The poles shall be internally painted up to 4'-0" above the base plate with a rust inhibitor / anti-corrosion coating. In addition to the internal paint, the pole shall also be externally painted up to 4'-0" above the base plate including base plate and full base cover with the rust inhibitor / anti-corrosion coating. This information shall be clearly stated in the shop drawings.

The pole and luminaire arm shall fit together to make a final luminaire mounting height of 35'-0" as specified in the plans.

The pole shall come complete with frangible coupling and a full height ventilated base cover. The base covers shall be made of weathering steel and be provided by the pole manufacturer. The frangible coupling and base cover will not be included in this pay item but will be paid for separately.

A grounding nut and stud shall be provided in the base of each pole at the handhole for lug attachment. The handhole shall be gasketed to meet U.L. requirements.

The pole shall meet the 2015 AASHTO LRFD Specifications for Structural Supports for Highway Signs, Luminaire and Traffic Signals with wind design velocity of 120 miles per hour with a mean recurrence interval of 1700 years. The pole will be able to support a luminaire, non-breakaway 30"x96" banner, and 36"x48" sign panel and meet 2015 AASHTO Specification.

Shipment:

The poles shall be carefully inspected at the factory prior to shipment to assure that the poles are complete and free of defects.

When poles are stacked together, they shall be supported with suitable spacers or shall otherwise be protected from dents and other potential shipping damage. The spacing and protective materials shall be suitable for and usable in the storage of the poles.

Installation:

The light pole shall be set plumb on the foundation without the use of shims, grout or any other leveling devices under the Pole Base. The mast arm shall be set at right angles to the centerline of the pavement. (The leveling area of the luminaire shall be set in a plane parallel to the roadway taking into consideration the upgrade or downgrade and the super-elevation of the roadway.)

This item shall be coordinated with the applicable luminaire (with pole wire and fusing), foundation, anchor bolts and breakaway devices.

Pole shall not be installed until luminaires are available for installation at the same time the poles are installed. Poles shall not be installed and left standing without a coordinated installation of the mast arm and luminaire. Poles shall not be paid unless the coordinated assembly, including the mast arm, and luminaire is complete.

Basis of Payment. This item will be paid for at the contract unit price each for LIGHT POLE, WEATHERING STEEL, 35 FT. M.H., 6 FT. MAST ARM, which shall be payment in full for furnishing, installing and performing the work described herein and as shown on the plans.

LIGHT POLE, SPECIAL

Description. This item shall consist of furnishing and installing light poles as specified herein, shown on the contract drawings and with Section 830 of the Standard Specification. This item shall include all of the internal wiring, fusing, anchor bolts, and the hardware required for final attachment to the foundation as shown in the drawings.

The light pole is as described in the Light Pole, Weathering Steel, 35 ft. M.H., 6 ft. Mast Arm specification in this contract but with two 6 ft. mast arms at 90 degrees.

Basis of Payment. This work shall be paid for at the contract unit price per each for LIGHT POLE, WEATHERING STEEL, 35 FT. M.H., 6 FT. MAST ARM, which shall be payment in full for furnishing, installing and performing the work described herein and as shown on the plans.

LIGHT POLE, SPECIAL, TYPE 2

Description. This item shall consist of furnishing and installing light poles as specified herein, shown on the contract drawings and with Section 830 of the Standard Specification. This item shall include all of the internal wiring, fusing, anchor bolts, and the hardware required for final attachment to the foundation as shown in the drawings.

Material:

The weathering steel light poles are square tapered steel as detailed on the contract drawings.

The pole shall come complete with a 3'-2" mast arm as shown in the plans. Both the pole and the mast arm shall be weathering steel. The pole shaft shall be 7-gauge weathering steel. The pole shall include an internal vibration damper. The pole shaft shall be square in cross section having flat sides, radiused corners and a uniform taper. A handhole shall be provided 1'-6" above the base.

The poles shall be internally painted up to 4'-0" above the base plate with a rust inhibitor / anti-corrosion coating. In addition to the internal paint, the pole shall also be externally painted up to 4'-0" above the base plate including base plate and full base cover with the rust inhibitor / anti-corrosion coating. This information shall be clearly stated in the shop drawings.

The pole and luminaire arm shall fit together to make a final luminaire mounting height of 15'-0" as specified in the plans.

The pole shall come complete with frangible coupling and a full height ventilated base cover. The base covers shall be made of weathering steel and be provided by the pole manufacturer. The frangible coupling and base cover will not be included in this pay item but will be paid for separately.

A grounding nut and stud shall be provided in the base of each pole at the handhole for lug attachment. The handhole shall be gasketed to meet U.L. requirements.

The pole shall meet the 2015 AASHTO LRFD Specifications for Structural Supports for Highway Signs, Luminaire and Traffic Signals with wind design velocity of 120 miles per hour with a mean recurrence interval of 1700 years. The pole will be able to support a luminaire and 36"x48" sign panel and meet 2015 AASHTO Specification.

Shipment:

The poles shall be carefully inspected at the factory prior to shipment to assure that the poles are complete and free of defects.

When poles are stacked together, they shall be supported with suitable spacers or shall otherwise be protected from dents and other potential shipping damage. The spacing and protective materials shall be suitable for and usable in the storage of the poles.

Installation:

The light pole shall be set plumb on the foundation without the use of shims, grout or any other leveling devices under the Pole Base. The mast arm shall be set at right angles to the centerline of the pavement. (The leveling area of the luminaire shall be set in a plane parallel to the roadway taking into consideration the upgrade or downgrade and the super-elevation of the roadway.)

This item shall be coordinated with the applicable luminaire (with pole wire and fusing), foundation, anchor bolts and breakaway devices.

Pole shall not be installed until luminaires are available for installation at the same time the poles are installed. Poles shall not be installed and left standing without a coordinated installation of the mast arm and luminaire. Poles shall not be paid unless the coordinated assembly, including the mast arm, and luminaire is complete.

Basis of Payment. This item will be paid for at the contract unit price each for LIGHT POLE, SPECIAL, TYPE 2, which shall be payment in full for furnishing, installing and performing the work described herein and as shown on the plans.

BASE COVER, LIGHT POLE

Description. This item shall consist of furnishing and installing light pole base covers for the proposed lighting unit as shown on the plans and as specified herein.

Proposed weathering steel base covers shall cover the entire anchor bolt and breakaway coupling assembly. It shall be the contractor's responsibility to verify the exact size required. The full base cover is a 2 piece 11 GA. weathering steel. The base covers shall contain ventilation slots for air circulation and drainage on all 4 sides. The base covers shall be as detailed on the plans. The base cover shall be provided by the pole manufacturer.

The dimension of the Base Cover, Light Pole is 17.5" x 17.5" and 13" high. The dimension of the Base Cover, Light Pole, Type 2 is 15.5" x 15.5" and 13" high.

Basis of Payment. This work shall be paid for at the contract unit price per each for BASE COVER, LIGHT POLE; or BASE COVER, LIGHT POLE, TYPE 2 which price shall include all the labor, material and equipment necessary to perform the work as specified herein.

BREAKAWAY DEVICE, COUPLING

Description. This work shall consist of furnishing and installing of the light pole breakaway device, coupling according to Section 838 of the Standard Specification and as specified herein.

The breakaway support system for light poles are couplings manufactured by Transpo Industries, Inc.

Breakaway Device, Coupling is 1-1/4" breakaway coupling, Pole-Safe Model No. 4125.

Breakaway Device, Coupling, Type 2 is 1" breakaway coupling, Pole-Safe Model No. 4100.

It shall be the Contractor's responsibility to verify the exact size required.

The breakaway couplings used for breakaway devices will be measured for payment as a set of four and not as each individual coupling used.

Basis of Payment. This work shall be paid for at the contract unit price per each for BREAKAWAY DEVICE, COUPLING; or BREAKAWAY DEVICE, COUPLING, TYPE 2, which price shall include all the labor, material and equipment necessary to perform the work as specified herein.

LIGHT POLE FOUNDATION, OFFSET

Description. This work shall consist of excavating, constructing, and backfilling offset light pole foundations in accordance with Section 836 of the Standard Specifications except as specified herein, and the details shown in the plans. Offset foundations shall be installed at locations where the utility conflict can be resolved by laterally offsetting the drilled shaft of the foundation.

The determination of foundation type shall be made in the field by the Engineer, based upon the actual locations of utilities. Payment will be made according quantity of each foundation type installed, and no additional compensation will be allowed for subtractions or additions to contract quantities for the various foundation types.

Excavation, including shoring, material disposal, and pumping, bailing or otherwise draining the excavated area shall not be paid for separately, but shall be included in the contract unit price for offset foundations.

Backfilling and thoroughly compacting material conforming to Article 1004 and shall not be paid for separately, but shall be considered as included in the contract unit price for offset foundations. Concrete shall cure in accordance with Article 1020.13 before being backfilled.

Basis of Payment. Offset foundations will be measured for payment in accordance with Article 836.04 of the Standard Specifications, and paid at the contract unit price per foot for LIGHT POLE FOUNDATION, of the diameter specified, OFFSET.

REMOVAL OF LIGHTING UNIT, SALVAGE

Description. This work shall consist of the removal of existing lighting system as described in Section 842 of the Standard Specification and as specified herein and shown in the contract plans.

The poles, mast arms, luminaires, and cables in the light poles shall be removed and shall remain the property of the Village of Buffalo Grove. It shall be delivered and unloaded at the Village of Buffalo Grove or as directed by the Engineer.

Basis of Payment. This work will be paid for at the contract unit price per each for REMOVAL OF LIGHTING UNIT, SALVAGE, and shall include all labor, material and equipment necessary to perform the work as specified in the plan documentation and as herein specified.

TEMPORARY LIGHTING CONTROLLER

Description. This work shall consist of furnishing and installing an electrical controller as specified in Section 825 of the Standard Specifications and as specified herein.

The temporary lighting controller shall be 120/240 volt, 100 amps, single phase and 3 wires. The enclosure and control components may be used (not new) but must be able to function properly and safely according to Section 1068 of the Standard Specification and the National Electrical Code (NEC). The temporary lighting will be controlled by photocell mounted on the cabinet, there will be 8 - 30 amp double pole circuit breakers, and the cabinet and control components must be grounded.

The removal of the temporary lighting controller shall not be paid for separately but shall be included in this pay item. The temporary lighting controller shall not be removed until the proposed lighting is in place and the proposed lighting controller is functioning.

Basis of Payment. This work will be paid for at the contract unit price per each for TEMPORARY LIGHTING CONTROLLER, and shall include all material, labor and equipment necessary to perform the work as specified in the plan documentation and as herein specified.

TEMPORARY WOOD POLE

Description. This work shall consist of furnishing and installing a temporary wood pole according to Section 830 of the Standard Specifications and as specified herein and shown in the plans.

The wood pole material shall be according to Illinois Department of Transportation Standard Specifications for Road and Bridge Construction in Article 1069.04. The wood pole shall be installed according to Illinois Department of Transportation Standard Specifications for Road and Bridge Construction in Article 830.03 (c) and 830.04.

When specified in the contract plans, a 15 foot or 3 foot truss style mast arm shall be installed on a temporary wood pole with all the necessary hardware and accessories required. The mast arm shall be set at right angles to the centerline of the pavement.

Basis of Payment. This work will be paid for at the contract unit price per each for TEMPORARY WOOD POLE, 50 FT., CLASS 4; or TEMPORARY WOOD POLE, 50 FT., CLASS 4, 15 FT MAST ARM; or TEMPORARY WOOD POLE, 25 FT., CLASS 4, 3 FT MAST ARM, which price shall be payment in full for the material including guy wire, excavation, labor, and equipment necessary to complete the work described herein.

TEMPORARY LUMINAIRE

Description. This work shall consist of furnishing and installing a temporary luminaire per Section 821 except as revised in this special provision and the details in the plan.

Add the following to first paragraph of Article 1067(c) of the Standard Specifications:

“The reflector shall not be altered by paint or other opaque coatings which would cover or coat the reflecting surface. Control of the light distribution by any method other than the reflecting material and the aforementioned clear protective coating that will alter the reflective properties of the reflecting surface is unacceptable”

Add the following to Article 1067(f) of the Standard Specifications:

“The ballast shall be a High Pressure Sodium, high power factor, constant wattage auto-regulator, lead type (CWA) for operation on a nominal 240 volt system.”

Revise Article 1067(f)(1) of the Standard Specifications to read:

“The high pressure sodium, auto-regulator, lead type (CWA) ballast shall be designed to ANSI Standards and shall be designed and rated for operation on a nominal 240 volt system. The ballast shall provide positive lamp ignition at the input voltage of 216 volts. It shall operate the lamp over a range of input voltages from 216 to 264 volts without damage to the ballast. It shall provide lamp operation within lamp specifications for rated lamp life at input design voltage range. Operating characteristics shall produce output regulation not exceeding the following values:

Nominal Ballast Wattage	Maximum Ballast Regulation
750	25%
400	26%
310	26%
250	26%
150	24%
70	18%

For this measure, regulation shall be defined as the ratio of the lamp watt difference between the upper and lower operating curves to the nominal lamp watts; with the lamp watt difference taken within the ANSI trapezoid at the nominal lamp operating voltage point parallel to the minimum lamp volt line:

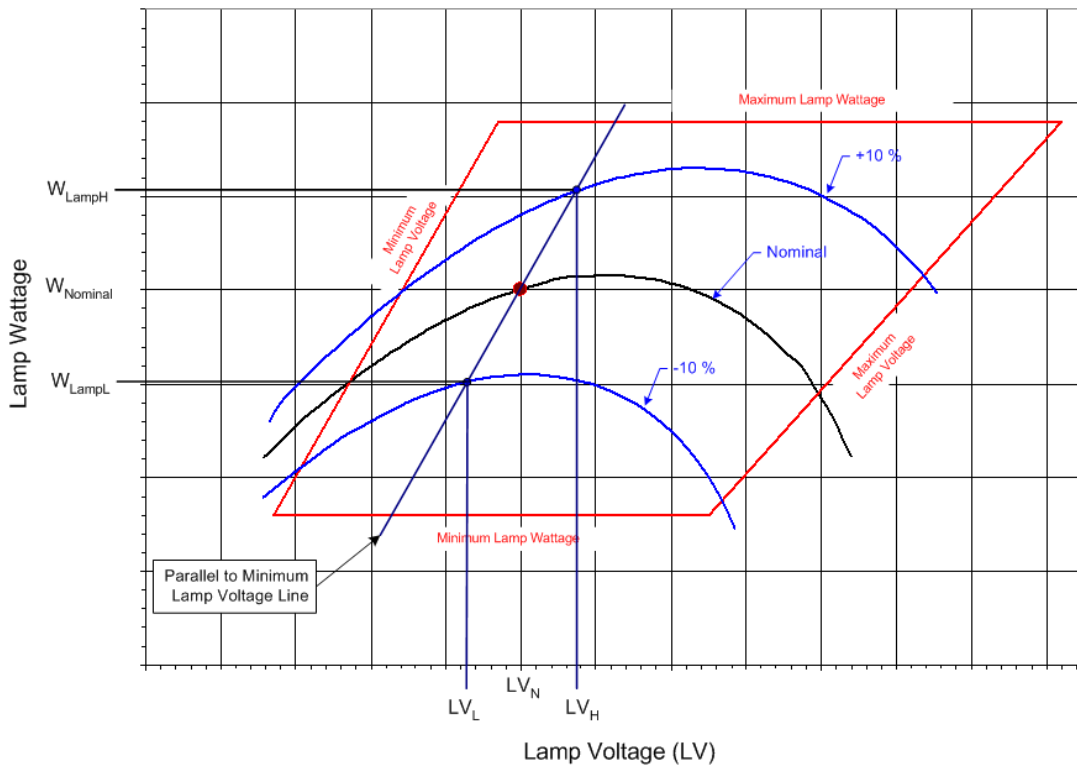

$$\text{Ballast Regulation} = \frac{W_{LampH} - W_{LampL}}{W_{LampN}} \times 100$$

where:

W_{LampH} = lamp watts at +10% line voltage when Lamp voltage = LV_H

W_{LampL} = lamp watts at - 10% line voltage when lamp voltage = LV_L

W_{lampN} = lamp watts at nominal lamp operating voltage = LV_N

Wattage	Nominal Lamp Voltage, LV _N	LV _L	LV _H
750	120v	115v	125v
400	100v	95v	105v
310	100v	95v	105v
250	100v	95v	105v
150	55v	50v	60v
70	52v	47v	57v

Ballast losses, based on cold bench tests, shall not exceed the following values:

Nominal Ballast Wattage	Maximum Ballast Losses
750	15%
400	20%
310	21%
250	24%
150	26%
70	34%

Ballast losses shall be calculated based on input watts and lamp watts at nominal system voltage as indicated in the following equation:

$$\text{Ballast Losses} = \frac{W_{Line} - W_{Lamp}}{W_{Lamp}} \times 100$$

where:

W_{line} = line watts at nominal system voltage

W_{lamp} = lamp watts at nominal system voltage

Ballast output to lamp. At nominal system voltage and nominal lamp voltage, the ballast shall deliver lamp wattage with the variation specified in the following table.

Nominal Ballast Wattage	Output to lamp variation
750	± 7.5%
400	± 7.5%
310	± 7.5%
250	± 7.5%
150	± 7.5%
70	± 7.5%

Example: For a 400w luminaire, the ballast shall deliver 400 watts ±7.5% at a lamp voltage of 100v for the nominal system voltage of 240v which is the range of 370w to 430w.

Ballast output over lamp life. Over the life of the lamp the ballast shall produce average output wattage of the nominal lamp rating as specified in the following

table. Lamp wattage readings shall be taken at 5-volt increments throughout the ballast trapezoid. Reading shall begin at the lamp voltage (Lv) specified in the table and continue at 5 volt increments until the right side of the trapezoid is reached. The lamp wattage values shall then be averaged and shall be within the specified value of the nominal ballast rating. Submittal documents shall include a tabulation of the lamp wattage vs. lamp voltage readings.

Nominal Ballast Wattage	LV Readings begin at	Maximum Wattage Variation
750	110v	± 7.5%
400	90v	± 7.5%
310	90v	± 7.5%
250	90v	± 7.5%
150	50v	± 7.5%
70	45v	± 7.5%

Example: For a 400w luminaire, the averaged lamp wattage reading shall not exceed the range of ±7.5% which is 370w to 430w”

Delete Article 1067.01(h) of the Standard Specifications.

Revise Article 1067.06(a)(1) of the Standard Specifications to read:

“The lamps shall be of the clear type and shall have a color of 1900° to 2200° Kelvin.”

Add the following table(s) to Article 1067 of the Standard Specifications:

**IDOT DISTRICT 1 LUMINAIRE PERFORMANCE TABLE
 TEMPORARY LIGHTING – 250 WATT HPS**

GIVEN CONDITIONS		
ROADWAY DATA	Pavement Width	79 (ft)
	Number of Lanes	6
	I.E.S. Surface Classification	R3
	Q-Zero Value	.07
LIGHT POLE DATA	Mounting Height	40 (ft)
	Mast Arm Length	15 (ft)

	Pole Set-Back From Edge of Pavement	12' one side and 17' opposite side (ft)
LUMINAIRE DATA	Lamp Type	HPS
	Lamp Lumens	28,000 – 29,000
	I.E.S. Vertical Distribution	Medium
	I.E.S. Control Of Distribution	Cutoff
	I.E.S. Lateral Distribution	Type III
	Total Light Loss Factor	0.7
LAYOUT DATA	Spacing	210 (ft)
	Configuration	Opposite
	Luminaire Overhang over edge of pavement	3' on one side and -2' on opposite side (ft)

NOTE: Variations from the above specified I.E.S. distribution pattern may be requested and acceptance of variations will be subject to review by the Engineer based on how well the performance requirements are met.

PERFORMANCE REQUIREMENTS

NOTE: These performance requirements shall be the minimum acceptable standards of photometric performance for the luminaire, based on the given conditions listed above.

LUMINANCE	Average Luminance, L_{AVE}	0.6 Cd/m ²
	Uniformity Ratio, L_{AVE}/L_{MIN}	3.5 (Max)
	Uniformity Ratio, L_{MAX}/L_{MIN}	6.0 (Max)
	Veiling Luminance Ratio, L_V/L_{AVE}	0.4 (Max)

Basis of Payment. This work will be paid for at the contract unit price per each for TEMPORARY LUMINAIRE, HIGH PRESSURE SODIUM VAPOR, HORIZONTAL MOUNT, 250 WATT, or TEMPORARY LUMINAIRE, HIGH PRESSURE SODIUM VAPOR, HORIZONTAL MOUNT, 100 WATT.

TEMPORARY ELECTRIC SERVICE INSTALLATION

Description. This work shall consist of all material and labor required to extend, connect or modify the electric services, as indicated or specified, which are over and above the work performed by the utility. This work shall be conducted according to Section 804 of the Standard Special Provision as specified herein.

The Contractor shall ascertain the work being provided by the electric utility and shall provide all additional material and work not included by other contract pay items required to complete the electric service work in complete compliance with the requirements of the utility. Materials shall be in accordance with the Standard Specifications.

No additional compensation will be allowed for work required for the electric service, even though not explicitly shown on the Drawings or specified herein

The removal of the temporary electric service installation shall not be paid for separately but shall be included in this pay item.

Basis of Payment. This work shall be paid for at the contract unit price per each for TEMPORARY ELECTRIC SERVICE INSTALLATION, which price shall include all labor, material and equipment necessary to perform the work as specified herein. This item may apply to the work at more than one service location and each will be paid for separately.

TEMPORARY MAST ARM, ALUMINUM, 15 FT

Description. This work shall consist of installing a mast arm on a temporary wood pole as described in Section 830 of the Standard Specification and as specified herein.

The temporary wood pole shall be clean and free of debris before installing the mast arm. The mast arm may be aluminum or steel and shall be set at right angles to the centerline of the road. Pole bands or clamps with bolts, nuts, lockwashers, and other necessary hardware shall be used to secure the installation of the mast arm on the pole.

Basis of Payment. This work will be paid for at the contract unit price per each for TEMPOARY MAST ARM, ALUMINUM, 15 FT., and shall include all labor, material and equipment necessary to perform the work as specified in the plan documentation and as herein specified.

State of Illinois
Department of Transportation
Bureau of Local Roads and Streets

SPECIAL PROVISION
FOR
INSURANCE

Effective: February 1, 2007
Revised: August 1, 2007

All references to Sections or Articles in this specification shall be construed to mean specific Section or Article of the Standard Specifications for Road and Bridge Construction, adopted by the Department of Transportation.

The Contractor shall name the following entities as additional insured under the Contractor's general liability insurance policy in accordance with Article 107.27:

Lake County Division of Transportation

Village of Buffalo Grove

Village of Lincolnshire

The entities listed above and their officers, employees, and agents shall be indemnified and held harmless in accordance with Article 107.26.



A. Submittal Date Contracting Agency District Office Aeronautics Local Agency Other Addendum #
 Previous survey request(s) submitted for this site? Yes No Date(s) of prior submittal(s)

B. Route Marked County(ies) District
 Section Project Number Job Number P- C- Contract Number

C. Borrow Location (Legal Description - indicate section, sub-section, township, range, and street address, if available.)
 Limits staked in field: Yes No Specify if: Staked Corners Approximate Center
 Latitude Longitude County(ies)

D. yds³ (m³) borrow from this site Borrow Site Size: acres (ha)
 Current Land Use (Check each which applies): Timber Row Crops Pasture Other (Describe)
 Tree Removal Yes No Number Acres

E. Name of Contractor Contact Person Phone
 Address
 Name of District Local Resident Engineer Phone E-mail

F. Has the site been cleared by IDOT for cultural resources within the past 5 years?
 Yes No Unknown

G. The request is number of requests for this project.

- ATTACHMENTS REQUIRED:**
1. Ground Level Color Photos
 2. U.S.G.S. 7.5' Topo. Quad. Map
 3. Aerial Photo
 4. Landowner Agreement (See page 2)
 5. Sketched Map with Landmarks

LEAVE THIS SPACE BLANK



Landowner Agreement
For BDE 2289



To whom it may concern:

I (we),

(Name and Address of the Property Owner)

owner(s) of said property, located:

(Indicate location of property by county, section, sub-section, township, range)

do hereby grant to the Illinois State Archeological Survey (ISAS), or their agents acting on behalf of Illinois Department of Transportation, permission to survey and/or test excavate said property;

do hereby grant permission for ISAS, or their agents, acting on behalf of the Illinois Department of Transportation, to remove artifacts and scientific samples from said property and agree that all artifacts and samples shall remain in public ownership, in the custody of ISAS at the University of Illinois, Urbana-Champaign;

and do hereby grant to the Contractor,

(Name and Address of Contractor)

permission to excavate and remove soil from said property for use on the construction project (Contract #).

(Signature of Property Owner)

(Name of Property Owner)

(Street Address of Property Owner)

(City, State, Zip Code of Property Owner)

(Phone Number of Property Owner)



Route FAU 2665	Marked Route Weiland Road	Section 18-00158-13-WR
Project Number XHE4(442)	County Lake	Contract Number 61F25

This plan has been prepared to comply with the provisions of the National Pollutant Discharge Elimination System (NPDES) Permit No. ILR10 (Permit ILR10), issues by the Illinois Environmental Protection Agency (IEPA) for storm water discharges from construction site activities.

I certify under penalty of law that this document and all attachments were prepared under my direction or supervision in accordance with a system designed to assure that qualified personnel properly gathered and evaluated the information submitted. Based on my inquiry of the person or persons who manage the system, or those persons directly responsible for gathering the information, the information submitted is, to the best of my knowledge and belief, true, accurate and complete. I am aware that there are significant penalties for submitting false information, including the possibility of fine and imprisonment for knowing violations.

Print Name Shane E. Schneider	Title County Engineer	Agency Lake County DoT
Signature 	Date 9/27/18	

I. Site Description

- A. Provide a description of the project location (include latitude and longitude):

The project is located at Weiland Road from Deerfield Parkway to Aptakisic Road, in Sections 21, 27 and 28 of Vernon Township, Lake County, Illinois. Approximate latitude of the project location is 42D 10' 44" N, and the longitude is 87D 56' 54" W.
- B. Provide a description of the construction activity which is subject of this plan:

The items of work include pavement reconstruction, PCC sidewalks, HMA bike paths, retaining walls, storm sewers, earth excavation, erosion control, landscaping, tree removal, proposed trees, lighting improvements and signal improvements.
- C. Provide the estimated duration of this project:

Estimated construction duration is one construction season.
- D. The total area of the construction site is estimated to be 17.1 acres.
 The total area of the site estimated to be disturbed by excavation, grading or other activities is 16.4 acres.
- E. The following is a weighted average of the runoff coefficient for this project after construction activities are completed:

Existing Runoff Coefficient = 0.72
 Post-Construction Runoff Coefficient = 0.73
- F. List all soils found within project boundaries. Include map unit name, slope information and erosivity:

Source: WSS: <http://websoilsurvey.nrcs.usda.gov/app/WebSoilSurvey.aspx>

MU Description

146A Elliott silt loam, 0 to 2 percent slopes
153A Pella silty clay loam, 0 to 2 percent slopes
223B Varna silt loam, 2 to 4 percent slopes
531C2 Markham silt loam, 4 to 6 percent slopes, eroded

G. Provide an aerial extent of wetland acreage at the site:

No wetlands present within the limits of the project.

H. Provide a description of potentially erosive areas associated with this project:

Areas around retaining walls and where benching is proposed may be susceptible to erosion during construction.

I. The following is a description of soil disturbing activities by stages, their locations, and their erosive factors (e.g. steepness of slopes, length of scopes, etc.):

The construction will take place in three separate stages. Stage 1 will include the construction of the east side of Weiland Road along with a sidewalk, walls, and temporary widening on the west side of the roadway. Stage 2 will include the construction of the west side of Weiland Road, including bike path. Stage 3 will include the construction of roadway medians and center lane pavement. In general 4:1 grading slopes are proposed throughout this project. The erosion control plans are presented according to these three (3) stages.

J. See the erosion control plans and/or drainage plans for this contract for information regarding drainage patterns, approximate slopes anticipated before and after major grading activities, locations where vehicles enter or exit the site and controls to prevent off site sediment tracking (to be added after contractor identifies locations), areas of soil disturbance, the location of major structural and non-structural controls identified in the plan, the location of areas where stabilization practices are expected to occur, surface waters (including wetlands) and locations where storm water is discharged to surface water including wetlands.

K. Identify who owns the drainage system (municipality or agency) this project will drain into:

The Lake County Division of Transportation owns the drainage system to which the project will drain.

L. The following is a list of General NPDES ILR40 permittees within whose reporting jurisdiction this project is located.

Lake County (0517)

M. The following is a list of receiving water(s) and the ultimate receiving water(s) for this site. The location of the receiving waters can be found on the erosion and sediment control plans:

Aptakasic Creek is the receiving water for this site, which is a part of Des Plaines River watershed.

N. Describe areas of the site that are to be protected or remain undisturbed. These areas may include steep slopes, highly erodible soils, streams, stream buffers, specimen trees, natural vegetation, nature preserves, etc.

Any trees outside of the grading limits within the project area shall be protected during construction.

O. The following sensitive environmental resources are associated with this project, and may have the potential to be impacted by the proposed development:

- Floodplain
- Wetland Riparian
- Threatened and Endangered Species
- Historic Preservation
- 303(d) Listed receiving waters for suspended solids, turbidity, or siltation
- Receiving waters with Total Maximum Daily Load (TMDL) for sediment, total suspended solids, turbidity, or siltation
- Applicable Federal, Tribal, State or Local Programs
- Other

1. 303(d) Listed receiving waters (fill out this section if checked above):

None

a. The name(s) of the listed water body, and identification of all pollutants causing impairment:

b. Provide a description of how erosion and sediment control practices will prevent a discharge of sediment resulting from a storm event equal to or greater than a twenty-five (25) year, twenty-four (24) hour rainfall event:

c. Provide a description of the location(s) of direct discharge from the project site to the 303(d) water body:

d. Provide a description of the location(s) of any dewatering discharges to the MS4 and/or water body:

2. TMDL (fill out this section if checked above)

a. The name(s) of the listed water body:

b. Provide a description of the erosion and sediment control strategy that will be incorporated into the site design that is consistent with the assumptions and requirements of the TMDL:

c. If a specific numeric waste load allocation has been established that would apply to the project's discharges, provide a description of the necessary steps to meet the allocation:

P. The following pollutants of concern will be associated with this construction project:

- | | |
|---|--|
| <input checked="" type="checkbox"/> Soil Sediment | <input checked="" type="checkbox"/> Petroleum (gas, diesel, oil, kerosene, hydraulic oil / fluids) |
| <input checked="" type="checkbox"/> Concrete | <input checked="" type="checkbox"/> Antifreeze / Coolants |
| <input checked="" type="checkbox"/> Concrete Truck waste | <input checked="" type="checkbox"/> Waste water from cleaning construction equipment |
| <input checked="" type="checkbox"/> Concrete Curing Compounds | <input type="checkbox"/> Other (specify) _____ |
| <input checked="" type="checkbox"/> Solid waste Debris | <input type="checkbox"/> Other (specify) _____ |
| <input checked="" type="checkbox"/> Paints | <input type="checkbox"/> Other (specify) _____ |
| <input checked="" type="checkbox"/> Solvents | <input type="checkbox"/> Other (specify) _____ |
| <input checked="" type="checkbox"/> Fertilizers / Pesticides | <input type="checkbox"/> Other (specify) _____ |

II. Controls

This section of the plan addresses the controls that will be implemented for each of the major construction activities described in I.C. above and for all use areas, borrow sites, and waste sites. For each measure discussed, the Contractor will be responsible for its implementation as indicated. The Contractor shall provide to the Resident Engineer a plan for the implementation of the measures indicated. The Contractor and subcontractors, will notify the Resident Engineer of any proposed changes, maintenance, or modifications to keep construction activities compliant with the Permit ILR10. Each such Contractor has signed the required certification on forms which are attached to, and are a part of, this plan:

- A. **Erosion and Sediment Controls:** At a minimum, controls must be coordinated, installed, and maintained to:
1. Minimize the amount of soil exposed during construction activity;
 2. Minimize the disturbance of steep slopes;
 3. Maintain natural buffers around surface waters, direct storm water to vegetated areas to increase sediment removal and maximize storm water infiltration, unless infeasible;
 4. Minimize soil compaction and, unless infeasible, preserve topsoil.

B. **Stabilization Practices:** Provided below is a description of interim and permanent stabilization practices, including

site- specific scheduling of the implementation of the practices. Site plans will ensure that existing vegetation is preserved where attainable and disturbed portions of the site will be stabilized. Stabilization practices may include but are not limited to: temporary seeding, permanent seeding, mulching, geotextiles, sodding, vegetative buffer strips, protection of trees, preservation of mature vegetation, and other appropriate measures. Except as provided below in II(B)(1) and II(B)(2), stabilization measures shall be initiated **immediately** where construction activities have temporarily or permanently ceased, but in no case more than **one (1) day** after the construction activity in that portion of the site has temporarily or permanently ceases on all disturbed portions of the site where construction will not occur for a period of fourteen (14) or more calendar days.

1. Where the initiation of stabilization measures is precluded by snow cover, stabilization measures shall be initiated as soon as practicable.
2. On areas where construction activity has temporarily ceased and will resume after fourteen (14) days, a temporary stabilization method can be used.

The following stabilization practices will be used for this project:

- | | |
|---|--|
| <input checked="" type="checkbox"/> Preservation of Mature Vegetation | <input checked="" type="checkbox"/> Erosion Control Blanket / Mulching |
| <input type="checkbox"/> Vegetated Buffer Strips | <input checked="" type="checkbox"/> Sodding |
| <input checked="" type="checkbox"/> Protection of Trees | <input checked="" type="checkbox"/> Geotextiles |
| <input checked="" type="checkbox"/> Temporary Erosion Control Seeding | <input type="checkbox"/> Other (specify) _____ |
| <input type="checkbox"/> Temporary Turf (Seeding, Class 7) | <input type="checkbox"/> Other (specify) _____ |
| <input type="checkbox"/> Temporary Mulching | <input type="checkbox"/> Other (specify) _____ |
| <input checked="" type="checkbox"/> Permanent Seeding | <input type="checkbox"/> Other (specify) _____ |

Describe how the stabilization practices listed above will be utilized during construction:

Preservation of Mature Vegetation and Protection of Trees: All trees outside of the limits of grading shall be protected prior to any other construction work in the area. Tree Protection and Preservation is shown on the erosion control plan.

Temporary Erosion Control Seeding: A quantity for temporary erosion control seeding has been included in the plans for the placement in disturbed areas or as directed by the Engineer in accordance with the IDOT Standard Specifications for Road and Bridge Construction (latest edition) as a measure if the area cannot be permanently seeded.

Permanent Seeding: Seeding, Class 2A is proposed as the permanent vegetation on the Landscaping Plan.

Erosion Control Blanket/Mulching: Erosion Control Blanket shall be placed on top of all of the seeding areas as shown on the Landscaping Plan.

Sodding shall be applied to all areas shown on the Landscaping Plan.

Geotextiles shall be used where Perimeter Erosion Barrier is shown on the Erosion Control Plan.

Describe how the stabilization practices listed above will be utilized after construction activities have been completed:

Protection of Trees shall remain in place after construction is finished until most of the permanent vegetation has been established. **Temporary Erosion Control Seeding** shall provide stabilization until the permanent seeding can be established.

- C. **Structural Practices:** Provided below is a description of structural practices that will be implemented, to the degree attainable, to divert flows from exposed soils, store flows or otherwise limit runoff and the discharge of pollutants from exposed areas of the site. Such practices may include but are not limited to: perimeter erosion barrier, earth dikes, drainage swales, sediment traps, ditch checks, subsurface drains, pipe slope drains, level spreaders, storm drain inlet protection, rock outlet protection, reinforced soil retaining systems, gabions, and temporary or permanent sediment basins. The installation of these devices may be subject to Section 404 of the Clean Water Act.

The following stabilization practices will be used for this project:

- | | |
|--|--|
| <input checked="" type="checkbox"/> Perimeter Erosion Barrier | <input type="checkbox"/> Rock Outlet Protection |
| <input checked="" type="checkbox"/> Temporary Ditch Check | <input checked="" type="checkbox"/> Riprap |
| <input checked="" type="checkbox"/> Storm Drain Inlet Protection | <input type="checkbox"/> Gabions |
| <input checked="" type="checkbox"/> Sediment Trap | <input type="checkbox"/> Slope Mattress |
| <input type="checkbox"/> Temporary Pipe Slope Drain | <input type="checkbox"/> Retaining Walls |
| <input type="checkbox"/> Temporary Sediment Basin | <input type="checkbox"/> Slope Walls |
| <input type="checkbox"/> Temporary Stream Crossing | <input type="checkbox"/> Concrete Revetment Mats |
| <input type="checkbox"/> Stabilized Construction Exits | <input type="checkbox"/> Level Spreaders |
| <input type="checkbox"/> Turf Reinforcement Mats | <input type="checkbox"/> Other (specify) _____ |
| <input type="checkbox"/> Permanent Check Dams | <input type="checkbox"/> Other (specify) _____ |
| <input type="checkbox"/> Permanent Sediment Basin | <input type="checkbox"/> Other (specify) _____ |
| <input type="checkbox"/> Aggregate Ditch | <input type="checkbox"/> Other (specify) _____ |
| <input type="checkbox"/> Paved Ditch | <input type="checkbox"/> Other (specify) _____ |

Describe how the structural practices listed above will be utilized during construction:

Perimeter Erosion Barrier: Perimeter Erosion Barrier will be installed along the downslope areas of the construction limits as indicated in the plans or as approved by the Engineer, according to LCDOT Standard LC2051, to prevent sediment from leaving the site.

Temporary Ditch Checks: Temporary Ditch Checks will be placed along all ditch flow lines, or as approved by the Engineer, to minimize erosion and sediment runoff, according to LCDOT Standard LC2050.

Storm Drain Inlet Protection: Storm Drain Inlet Protection shall be placed on all drainage structures with open lids or grates and inlet pipes/culverts as shown on the staged Erosion Control Plans. Inlet filters shall be checked and cleaned if necessary after major rainfall event. Inlet and Pipe Protection shall be installed per IDOT Standard 280001-07.

Riprap: Riprap shall be placed to protect the culvert end sections.

Describe how the structural practices listed above will be utilized after construction activities have been completed:

Perimeter Erosion Barrier, Temporary Ditch Checks, and Storm Drain Inlet Protection shall remain in place after construction is completed until vegetation has been established.

Riprap shall remain in place after the completion of the project for permanent stabilization measures.

D. Treatment Chemicals

Will polymer flocculents or treatment chemicals be utilized on this project: Yes No

If yes above, identify where and how polymer flocculents or treatment chemicals will be utilized on this project.

Flocculation powder shall be used in the proposed stormwater storage area in order to increase the settling of sediment particles prior to any discharges offsite.

E. Permanent Storm Water Management Controls: Provided below is a description of measures that will be installed during the construction process to control volume and pollutants in storm water discharges that will occur after construction operations have been completed. The installation of these devices may be subject to Section 404 of the Clean Water act.

1. Such practices may include but are not limited to: storm water detention structures (including wet ponds), storm water retention structures, flow attenuation by use of open vegetated swales and natural depressions, infiltration of runoff on site, and sequential systems (which combine several practices).

The practices selected for implementation were determined on the basis of the technical guidance in Chapter 41 (Construction Site Storm Water Pollution Control) of the IDOT Bureau of Design & Environment Manual. If practices other than those discussed in Chapter 41 are selected for implementation or if practices are applied to situations different from those covered in Chapter 41, the technical basis for such decisions will be explained below.

2. Velocity dissipation devices will be placed at discharge locations and along the length of any outfall channel as necessary to provide a non-erosive velocity flow from the structure to a water course so that the natural physical and biological characteristics and functions are maintained and protected (e.g. maintenance of hydrologic conditions such as the hydroperiod and hydrodynamics present prior to the initiation of construction activities).

Description of permanent storm water management controls:

Due to limited right-of-way, a majority of the drainage on the project is conveyed through storm sewer pipes. For water quality measures, catch basins, swales, and ditches shall be used where practicable near discharge areas into waterways.

- F. **Approved State or Local Laws:** The management practices, controls, and provisions contained in this plan will be in accordance with IDOT specifications, which are at least as protective as the requirements contained in the Illinois Environmental Protection Agency's Illinois Urban Manual. Procedures and requirements specified in applicable sediment and erosion site plans or storm water management plans approved by local officials shall be described or incorporated by reference in the space provided below. Requirements specified in sediment and erosion site plans, site permits, storm water management site plans or site permits approved by local officials that are applicable to protecting surface water resources are, upon submittal of an NOI, to be authorized to discharge under the Permit ILR10 incorporated by reference and are enforceable under this permit even if they are not specifically included in the plan.

Description of procedures and requirements specified in applicable sediment and erosion site plans or storm water management plans approved by local officials:

All practices are in accordance with Lake County Division of Transportation Standard Details, IDOT Standard Specifications for Road and Bridge Construction, IDOT Supplemental Specifications and Recurring Special Provisions, and any details included in the plan set.

- G. **Contractor Required Submittals:** Prior to conducting any professional services at the site covered by this plan, the Contractor and each subcontractor responsible for compliance with the permit shall submit to the Resident Engineer a Contractor Certification Statement, BDE 2342a.

1. The Contractor shall provide a construction schedule containing an adequate level of detail to show major activities with implementation of pollution prevention BMPs, including the following items:
 - Approximate duration of the project, including each stage of the project
 - Rainy season, dry season, and winter shutdown dates
 - Temporary stabilization measures to be employed by contract phases
 - Mobilization time frame
 - Mass clearing and grubbing/roadside clearing dates
 - Deployment of Erosion Control Practices
 - Deployment of Sediment Control Practices (including stabilized construction entrances/exits)
 - Deployment of Construction Site Management Practices (including concrete washout facilities, chemical storage, refueling locations, etc.)
 - Paving, saw-cutting, and any other pavement related operations
 - Major planned stockpiling operations
 - Time frame for other significant long-term operations or activities that may plan non-storm water discharges such as dewatering, grinding, etc.
 - Permanent stabilization activities for each area of the project
2. The Contractor and each subcontractor shall provide, as an attachment to their signed Contractor Certification Statement, a discussion of how they will comply with the requirements of the permit in regard to the following items and provide a graphical representation showing location and type of BMPs to be used when applicable:

- Vehicle Entrances and Exits - Identify type and location of stabilized construction entrances and exits to be used and how they will be maintained.
- Material delivery, Storage, and Use - Discuss where and how materials including chemicals, concrete curing compounds, petroleum products, etc. will be stored for this project.
- Stockpile Management - Identify the location of both on-site and off-site stockpiles. Discuss what BMPs will be used to prevent pollution of storm water from stockpiles.
- Waste Disposal - Discuss methods of waste disposal that will be used for this project.
- Spill Prevention and Control - Discuss steps that will be taken in the event of a material spill (chemicals, concrete curing compounds, petroleum, etc.).
- Concrete Residuals and Washout Wastes - Discuss the location and type of concrete washout facilities to be used on this project and how they will be signed and maintained.
- Litter Management - Discuss how litter will be maintained for this project (education of employees, number of dumpsters, frequency of dumpster pick-up, etc.).
- Vehicle and Equipment Cleaning and Maintenance - Identify where equipment cleaning and maintenance locations for this project and what BMPs will be used to ensure containment and spill prevention.
- Dewatering Activities - Identify the controls which will be used during dewatering operations to ensure sediments will not leave the construction site.
- Polymer Flocculants and Treatment Chemicals - Identify the use and dosage of treatment chemicals and provide the Resident Engineer with Material Safety Data Sheets. Describe procedures on how the chemicals will be used and identify who will be responsible for the use and application of these chemicals. The selected individual must be trained on the established procedures.
- Additional measures indicated in the plan.

III. Maintenance

When requested by the Contractor, the Resident Engineer will provide general maintenance guides to the Contractor for the practices associated with this project. The following additional procedures will be used to maintain, in good and effective operating conditions, the vegetation, erosion and sediment control measures and other protective measures identified in this plan. It will be Contractor's responsibility to attain maintenance guidelines for any manufactured BMPs which are to be installed and maintained per manufacture's specifications.

--

IV. Inspections

Qualified personnel shall inspect disturbed areas of the construction site which have not yet been finally stabilized, structural control measures, and locations where vehicles and equipment enter and exit the site using IDOT Storm Water Pollution Prevention Plan Erosion Control Inspection Report (BC 2259). Such inspections shall be conducted at least once every seven (7) calendar days and within twenty-four (24) hours of the end of a storm or by the end of the following business or work day that is 0.5 inch or greater or equivalent snowfall.

Inspections may be reduced to once per month when construction activities have ceased due to frozen conditions. Weekly inspections will recommence when construction activities are conducted, or if there is 0.5" or greater rain event, or a discharge due to snowmelt occurs.

If any violation of the provisions of this plan is identified during the conduct of the construction work covered by this plan, the Resident Engineer shall notify the appropriate IEPA Field Operations Section office by e-mail at: epa.swnoncomp@illinois.gov, telephone or fax within twenty-four (24) hours of the incident. The Resident Engineer shall then complete and submit an "Incidence of Non-Compliance" (ION) report for the identified violation within five (5) days of the incident. The Resident Engineer shall use forms provided by IEPA and shall include specific information on the cause of noncompliance, actions which were taken to prevent any further causes of noncompliance, and a statement detailing any environmental impact which may have resulted from the noncompliance. All reports of non-compliance shall be signed by a responsible authority in accordance with Part VI. G of the Permit ILR10.

The Incidence of Non-Compliance shall be mailed to the following address:

Illinois Environmental Protection Agency
Division of Water Pollution Control
Attn: Compliance Assurance Section
1021 North Grand East
Post Office Box 19276
Springfield, Illinois 62794-9276

Additional Inspections Required:

--

V. Failure to Comply

Failure to comply with any provisions of this Storm Water Pollution Prevention Plan will result in the implementation of a National Pollutant Discharge Elimination System/Erosion and Sediment Control Deficiency Deduction against the Contractor and/or penalties under the Permit ILR10 which could be passed on to the Contractor.



Prior to conducting any professional services at the site covered by this contract, the Contractor and every subcontractor must complete and return to the Resident Engineer the following certification. A separate certification must be submitted by each firm. Attach to this certification all items required by Section II.G of the Storm Water Pollution Prevention Plan (SWPPP) which will be handled by the Contractors/subcontractor completing this form.

Route FAU 2665	Marked Route Weiland Road	Section 18-00158-13-WR
Project Number XHE4(442)	County Lake	Contract Number 61F25

This certification statement is a part of SWPPP for the project described above, in accordance with the General NPDES Permit No. ILR10 issued by the Illinois Environmental Protection Agency.

I certify under penalty of law that I understand the terms of the Permit No. ILR10 that authorizes the storm water discharges associated with industrial activity from the construction site identified as part of this certification.

In addition, I have read and understand all of the information and requirements stated in SWPPP for the above mentioned project; I have received copies of all appropriate maintenance procedures; and, I have provided all documentation required to be in compliance with the Permit ILR10 and SWPPP and will provide timely updates to these documents as necessary.

- Contractor
- Sub-Contractor

Print Name

Signature

Title

Date

Name of Firm

Telephone

Street Address

City/State/Zip

Items which the Contractor/subcontractor will be responsible for as required in Section II.G. of SWPPP:

Soil Map—Lake County, Illinois



Map Scale: 1:7,340 if printed on A portrait (8.5" x 11") sheet.

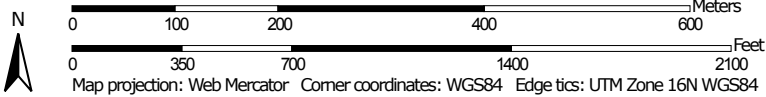





































Natural Resources
Conservation Service

Web Soil Survey
National Cooperative Soil Survey

327

6/18/2018
Page 1 of 3

MAP LEGEND

-  Area of Interest (AOI)
-  Soils
-  Soil Map Unit Polygons
-  Soil Map Unit Lines
-  Soil Map Unit Points
- Special Point Features**
 -  Blowout
 -  Borrow Pit
 -  Clay Spot
 -  Closed Depression
 -  Gravel Pit
 -  Gravelly Spot
 -  Landfill
 -  Lava Flow
 -  Marsh or swamp
 -  Mine or Quarry
 -  Miscellaneous Water
 -  Perennial Water
 -  Rock Outcrop
 -  Saline Spot
 -  Sandy Spot
 -  Severely Eroded Spot
 -  Sinkhole
 -  Slide or Slip
 -  Sodic Spot
-  Spoil Area
-  Stony Spot
-  Very Stony Spot
-  Wet Spot
-  Other
-  Special Line Features
- Water Features**
 -  Streams and Canals
- Transportation**
 -  Rails
 -  Interstate Highways
 -  US Routes
 -  Major Roads
 -  Local Roads
- Background**
 -  Aerial Photography

MAP INFORMATION

The soil surveys that comprise your AOI were mapped at 1:12,000.

Please rely on the bar scale on each map sheet for map measurements.

Source of Map: Natural Resources Conservation Service
 Web Soil Survey URL:
 Coordinate System: Web Mercator (EPSG:3857)

Maps from the Web Soil Survey are based on the Web Mercator projection, which preserves direction and shape but distorts distance and area. A projection that preserves area, such as the Albers equal-area conic projection, should be used if more accurate calculations of distance or area are required.

This product is generated from the USDA-NRCS certified data as of the version date(s) listed below.

Soil Survey Area: Lake County, Illinois
 Survey Area Data: Version 12, Oct 1, 2017

Soil map units are labeled (as space allows) for map scales 1:50,000 or larger.

Date(s) aerial images were photographed: Jul 3, 2011—Oct 22, 2016

The orthophoto or other base map on which the soil lines were compiled and digitized probably differs from the background imagery displayed on these maps. As a result, some minor shifting of map unit boundaries may be evident.

Map Unit Legend

Map Unit Symbol	Map Unit Name	Acres in AOI	Percent of AOI
146A	Elliott silt loam, 0 to 2 percent slopes	10.3	24.9%
153A	Pella silty clay loam, 0 to 2 percent slopes	7.5	18.2%
223B	Varna silt loam, 2 to 4 percent slopes	23.6	57.0%
531C2	Markham silt loam, 4 to 6 percent slopes, eroded	0.0	0.0%
Totals for Area of Interest		41.4	100.0%



**Storm Water Pollution Prevention Plan
Erosion Control Inspection Report**

Date of Inspection: _____ County: _____
 Name of Inspector: _____ Section: _____
 Type of Inspection: Weekly Route: _____
 >0.5" Precip. Precip. Amt: _____ " District: _____
 Contractor: _____ Contract No: _____
 Subs: _____ Job No. _____
 _____ Project: _____
 NPDES/ESC Deficiency Deduction: \$ _____ NPDES Permit No: _____
 Total Disturbed Area: _____ acre Ready for Final Cover: _____ acre
 Final Cover Established: _____ acre

Erosion and Sediment Control Practices

Item # / BMP		YES	NO	N/A
1.	Slopes: Do all slopes and exposed areas where soil disturbing activities have temporarily or permanently ceased, and not permanently stabilized, have adequate temporary seed or other stabilization in accordance with the NPDES permitted 7 and 14 day rule?	<input type="checkbox"/>	<input type="checkbox"/>	<input type="checkbox"/>
2.	Ditches Are all ditches (existing and temporary) clear of sediment and/or debris? Do all ditches have adequate stabilization and structural practices in place?	<input type="checkbox"/> <input type="checkbox"/>	<input type="checkbox"/> <input type="checkbox"/>	<input type="checkbox"/> <input type="checkbox"/>
3.	Perimeter Erosion Barrier: Are all perimeter erosion barriers in good working order? Has perimeter barrier no longer needed been removed and the area stabilized?	<input type="checkbox"/> <input type="checkbox"/>	<input type="checkbox"/> <input type="checkbox"/>	<input type="checkbox"/> <input type="checkbox"/>
4.	Temporary Ditch Checks: Are all temporary ditch checks in good working order? Are the current ditch checks adequate to control erosion?	<input type="checkbox"/> <input type="checkbox"/>	<input type="checkbox"/> <input type="checkbox"/>	<input type="checkbox"/> <input type="checkbox"/>
5.	Temp Diversions/ Slope Drains: Are all Temporary Diversions and Slope Drains functioning properly?	<input type="checkbox"/>	<input type="checkbox"/>	<input type="checkbox"/>
6.	Inlet Protection: Are ALL inlet protection devices in good working order? Are ALL inlet filters less than 25% full and fabric unobstructed?	<input type="checkbox"/> <input type="checkbox"/>	<input type="checkbox"/> <input type="checkbox"/>	<input type="checkbox"/> <input type="checkbox"/>
7.	Sediment Basins/Traps: Are ALL sediment basins/traps in good working order? Does sufficient capacity exist for the design stormwater event?	<input type="checkbox"/> <input type="checkbox"/>	<input type="checkbox"/> <input type="checkbox"/>	<input type="checkbox"/> <input type="checkbox"/>
8.	Areas of Interest – Wetland/Prairie/Tree Preservation: Has the contractor remained clear of all designated “no entry” areas? Are all “no intrusion” areas adequately marked to prevent accidental entry?	<input type="checkbox"/> <input type="checkbox"/>	<input type="checkbox"/> <input type="checkbox"/>	<input type="checkbox"/> <input type="checkbox"/>
9.	Stock Piles: Are all stockpiles properly situated and maintained to prevent runoff and protected to minimize discharge of materials or residue in case of erosion?	<input type="checkbox"/>	<input type="checkbox"/>	<input type="checkbox"/>
10.	Borrow/Waste Sites: Are all borrow and waste locations, including those located offsite, in compliance with NPDES requirements?	<input type="checkbox"/>	<input type="checkbox"/>	<input type="checkbox"/>
11.	Other Installations: Are all other BMP installations shown in the plans properly functioning? (note in comments)	<input type="checkbox"/>	<input type="checkbox"/>	<input type="checkbox"/>

General Site Maintenance Required of the Permit

12.	Vehicle Tracking: Is the site free from mud, sediment and debris from the vehicles entering/leaving off road areas throughout the site? Are Stabilized Construction field entrances properly located? Are Stabilized Construction field entrances in good working condition?	<input type="checkbox"/> <input type="checkbox"/> <input type="checkbox"/>	<input type="checkbox"/> <input type="checkbox"/> <input type="checkbox"/>	<input type="checkbox"/> <input type="checkbox"/> <input type="checkbox"/>
-----	---	--	--	--



Illinois Environmental Protection Agency

1021 North Grand Avenue East • P.O. Box 19276 • Springfield • Illinois • 62794-9276 • (217) 782-3397

Division of Water Pollution Control Notice of Intent (NOI) for General Permit to Discharge Storm Water Associated with Construction Site Activities

This fillable form may be completed online, a copy saved locally, printed and signed before it is submitted to the Permit Section at the above address.

For Office Use Only

OWNER INFORMATION

Permit No. ILR10 _____

Company/Owner Name: Lake County Division of Transportation

Mailing Address: 600 W. Winchester Rd

Phone: 847-377-7400

City: Libertyville State: IL Zip: 60048

Fax: 847-984-5888

Contact Person: Thomas Somodji E-mail: TSomodji@lakecountyil.gov

Owner Type (select one) County

CONTRACTOR INFORMATION

MS4 Community: Yes No

Contractor Name: _____

Mailing Address: _____ Phone: _____

City: _____ State: _____ Zip: _____ Fax: _____

CONSTRUCTION SITE INFORMATION

Select One: New Change of information for: ILR10 _____

Project Name: Weiland Road (Deerfield Parkway to Aptakisic Road) County: Lake

Street Address: Weiland Road and Pauline Avenue City: Buffalo Grove IL Zip: 60089

Latitude: 42 10 44 Longitude: -87 56 54 21, 28 43N 11E
(Deg) (Min) (Sec) (Deg) (Min) (Sec) Section Township Range

Approximate Construction Start Date Apr 22, 2019 Approximate Construction End Date Nov 29, 2019

Total size of construction site in acres: 17.1

If less than 1 acre, is the site part of a larger common plan of development?

Yes No

Fee Schedule for Construction Sites:
Less than 5 acres - \$250
5 or more acres - \$750

STORM WATER POLLUTION PREVENTION PLAN (SWPPP)

Has the SWPPP been submitted to the Agency? Yes No

(Submit SWPPP electronically to: epa.constilr10swppp@illinois.gov)

Location of SWPPP for viewing: Address: 600 W. Winchester Rd City: Libertyville

SWPPP contact information: Inspector qualifications:

Contact Name: Petro Kravets P.E.

Phone: 630-735-3392 Fax: 630-773-3975 E-mail: PKravets@civiltchinc.com

Project inspector, if different from above Inspector qualifications:

Inspector's Name: _____

Phone: _____ Fax: _____ E-mail: _____

This Agency is authorized to require this information under Section 4 and Title X of the Environmental Protection Act (415 ILCS 5/4, 5/39). Failure to disclose this information may result in: a civil penalty of not to exceed \$50,000 for the violation and an additional civil penalty of not to exceed \$10,000 for each day during which the violation continues (415 ILCS 5/42) and may also prevent this form from being processed and could result in your application being denied. This form has been approved by the Forms Management Center.

TYPE OF CONSTRUCTION (select one)

Construction Type Transportation

SIC Code: _____

Type a detailed description of the project:

The Weiland Road Improvement consists of the reconstruction and widening of Weiland Road, between Deerfield Parkway and Aptakisic Road, into a five-lane highway section with pedestrian and cyclist accommodations. Retaining walls shall be provided in areas along the project corridor and a new enclosed drainage system shall be installed.

HISTORIC PRESERVATION AND ENDANGERED SPECIES COMPLIANCE

Has the project been submitted to the following state agencies to satisfy applicable requirements for compliance with Illinois law on:

Historic Preservation Agency Yes No

Endangered Species Yes No

RECEIVING WATER INFORMATION

Does your storm water discharge directly to: Waters of the State or Storm Sewer

Owner of storm sewer system: Lake County Division of Transportation

Name of closest receiving water body to which you discharge: _____

Mail completed form to: Illinois Environmental Protection Agency
Division of Water Pollution Control
Attn: Permit Section
Post Office Box 19276
Springfield, Illinois 62794-9276
or call (217) 782-0610
FAX: (217) 782-9891

Or submit electronically to: epa.constilr10swppp@illinois.gov

I certify under penalty of law that this document and all attachments were prepared under my direction and supervision in accordance with a system designed to assure that qualified personnel properly gather and evaluate the information submitted. Based on my inquiry of the person or persons who manage this system, or those persons directly responsible for gathering the information, the information submitted is, to the best of my knowledge and belief, true, accurate, and complete. I am aware that there are significant penalties for submitting false information, including the possibility of fine and imprisonment. In addition, I certify that the provisions of the permit, including the development and implementation of a storm water pollution prevention plan and a monitoring program plan, will be complied with.

Any person who knowingly makes a false, fictitious, or fraudulent material statement, orally or in writing, to the Illinois EPA commits a Class 4 felony. A second or subsequent offense after conviction is a Class 3 felony. (415 ILCS 5/44(h))

Owner Signature:

Date:

Printed Name:

Title:

INSTRUCTIONS FOR COMPLETION OF CONSTRUCTION ACTIVITY NOTICE OF INTENT (NOI) FORM

Submit original, electronic or facsimile copies. Facsimile and/or electronic copies should be followed-up with submission of an original signature copy as soon as possible. Please write "copy" under the "For Office Use Only" box in the upper right hand corner of the first page.

This fillable form may be completed online, a copy saved locally, printed and signed before it is submitted to the Permit Section at:

Illinois Environmental Protection Agency
Division of Water Pollution Control
Permit Section
Post Office Box 19276
Springfield, Illinois 62794-9276
or call (217) 782-0610

FAX: (217) 782-9891

Or submit electronically to: epa.constilr10swppp@illinois.gov

Reports must be typed or printed legibly and signed.

Any facility that is not presently covered by the General NPDES Permit for Storm Water Discharges From Construction Site Activities is considered a new facility.

If this is a change in your facility information, renewal, etc., please fill in your permit number on the appropriate line, changes of information or permit renewal notifications do not require a fee.

NOTE: FACILITY LOCATION IS NOT NECESSARILY THE FACILITY MAILING ADDRESS, BUT SHOULD DESCRIBE WHERE THE FACILITY IS LOCATED.

Use the formats given in the following examples for correct form completion.

	Example	Format
Section	12	1 or 2 numerical digits
Township	12N	1 or 2 numerical digits followed by "N" or "S"
Range	12W	1 or 2 numerical digits followed by "E" or "W"

For the Name of Closest Receiving Waters, do not use terms such as ditch or channel. For unnamed tributaries, use terms which include at least a named main tributary such as "Unnamed Tributary to Sugar Creek to Sangamon River."

Submission of initial fee and an electronic submission of Storm Water Pollution Prevention Plan (SWPPP) for Initial Permit prior to the Notice of Intent being considered complete for coverage by the ILR10 General Permits. Please make checks payable to: Illinois EPA at the above address.

Construction sites with less than 5 acres of land disturbance - fee is \$250.

Construction sites with 5 or more acres of land disturbance - fee is \$750.

SWPPP should be submitted electronically to: epa.constilr10swppp@illinois.gov. When submitting electronically, use Project Name and City as indicated on NOI form.



STORMWATER MANAGEMENT COMMISSION

January 25, 2017

Thomas Somodji
Lake County Division of Transportation
600 W Winchester Road
Libertyville, IL 60048

Subject: Watershed Development Permit #C16-83-016
Weiland Rd Improvements between Woodstone Dr. and Rt. 22

Dear Mr. Somodji:

Accompanying this letter is the required Watershed Development Permit (WDP) for the subject project including additional drive lanes and a section of new road between Aptakisic Road and IL Route 22. This approval is subject to the conditions on the back of the permit including the following:

- Provide prior notification to Tim Cook (of the SMC) of the pre-construction meeting at least 5 calendar days in advance to enable SMC attendance
- The project will impact waters of the U.S. (WOUS); state funds (or federal funds passed through the state) will be used for the project. As such, the following conditions are made part of this WDP:
 - A copy of the Section 404 permit for this project shall be provided for SMC files, upon receipt. No work may occur in WOUS prior to permit issuance by the Army Corps. You shall notify SMC immediately if the plans referenced in this letter are modified to the extent that additional wetland impacts may occur. Any proposed wetland impacts associated with plan modification(s) may require an amended Section 404 permit from the U.S. Army Corps of Engineers-Chicago District (USACE) and/or additional wetland mitigation prior to the commencement of work.
 - You shall submit documentation to SMC demonstrating compliance with the Interagency Wetland Policy Act (e.g., ledger showing credits assigned to the Weiland Road project), upon finalization by the USACE of the wetland impact acreage.

Discussion at the preconstruction meeting will include:

- Resident Engineer contact information
- Dewatering

500 W. Winchester Road • Libertyville, Illinois 60048 • 847/377-7700 • FAX 847/984-5747

- NPDES permit number
- Reduced copy of the permitted plan set that has been signed and sealed by a professional engineer

Provide an as-built submittal including:

- Copies of the native vegetation seed tags and/or landscaper invoices clearly showing the species of native vegetation that were planted
- As built grading for each detention pond constructed/modified to verify compliance with the permitted plan set

This approval is based on the plans entitled:

STATE OF ILLINOIS, DEPARTMENT OF TRANSPORTATION, DIVISION OF HIGHWAYS, PLANS FOR PROPOSED FEDERAL AID HIGHWAY, FAU RTE 2665 (WEILAND ROAD), WOODSTONE DRIVE TO IL ROUTE 22, ADD LANES, BIKE/PED PATH, AND INTERSECTION IMPROVEMENT, SECTION 07-00094-00-PV, PROJECT NO. XXX, LAKE COUNTY, C-XX-XXX-XX, PRELIMINARY, NOT FOR CONSTRUCTION, prepared by CivilTech, received by SMC December 23, 2016, 1148-sheets.

and Report entitled:

WEILAND ROAD IMPROVEMENTS, WOODSTONE DRIVE TO ILLINOIS ROUTE 22, Volumes I and II, prepared by CivilTech Engineering, received 12/23/2016.

We would like to be of assistance. Do not hesitate to contact Tim Cook at (847)377-7703 if you have questions or would like to set up the pre-construction meeting.

If you have any additional concerns that have not been addressed by the regulatory staff, you may contact Chief Engineer Kurt Woolford kwoolford@lakecountyil.gov or Executive Director Michael Warner mwarner@lakecountyil.gov at (847) 377-7700.

Sincerely,

LAKE COUNTY STORMWATER MANAGEMENT COMMISSION



Robert D. Gardiner, P.E., CFM
Permit Engineer



Kurt Woolford, P.E., CFM
Chief Engineer

Attachment As-Built Checklist

500 W. Winchester Road • Libertyville, Illinois 60048 • 847/377-7700 • FAX 847/984-5747

C: Tom Liliensiek – CivilTech Engineering
Barry Stuedemann – Stuedemann Environmental
Melyssa Navis – USACE (LRC-2016-90)
Darren Monico – Village of Buffalo Grove
Dan Krill – Lake County Planning, Building & Development

500 W. Winchester Road • Libertyville, Illinois 60048 • 847/377-7700 • FAX 847/984-5747

As-built Review Checklist

Revised April 25, 2005

Please provide the following information, where applicable, when submitting as-built plans to Lake County Stormwater Management Commission (SMC) for approval. Please ensure that the as-built information is annotated onto the permitted construction plans and is not a stand-alone current conditions exhibit.

- _____ Spot elevations, contours, and cross-sections for cut and fill areas located in the Regulatory Floodplain
- _____ Floodplain cut and fill calculations based on the as-built survey
- _____ Spot elevations and contours for all constructed detention and water quality treatment facilities, including:
 - 2-yr and 100-yr water elevation contours
 - Flared end section and restrictor inverts
 - Detailed topography for the emergency overflow spillway
 - Top of berm spot elevations surrounding detention facility
- _____ Detention volume calculations based on the as-built survey
- _____ Storm sewer locations, sizes, inverts and rim elevations
- _____ Top of curb elevations at locations of overland flow paths
- _____ Overland flow path (swale) as-built cross-section survey
(A minimum of 2 cross-sections with at least 3 points, one on either bank and one at the invert)
- _____ Low floor elevations/lowest adjacent grade elevations for structures adjacent to Regulatory Floodplain, overland flow paths, or detention facilities
- _____ Verification of at least 90% coverage, on an areal basis, of plants comprising a minimum of 50% of the native vegetation seed list as approved on the permitted plan set at the end of the second full growing season.



STORMWATER MANAGEMENT COMMISSION

**WATERSHED DEVELOPMENT PERMIT NUMBER
Permit #C16-83-016
HAS BEEN SECURED**

**Project: Weiland Road Improvements between Woodstone
and IL Route 22**

Date Issued: January 25, 2017

Lat/Long: 42.1574, -87.9537

PIN No.: 1533402126

Conditions:

- Install and maintain all SE/SC measures
- Minimize environmental impacts

Issued By: Robert D. Gardiner, PE, CFM
Permit Engineer

Kurt A. Woolford, PE, CFM, LEED AP
Chief Engineer

Notice to Contractors and Owners

Post this card at the site, visible from the street and so located as to permit the inspector to record the indicated inspections on the placard. Do not post in the interior of a building.

Inspectors and sheriff's deputies are instructed to stop all work where this permit card is not displayed.

Always mention the Watershed Development Permit number when referring to this project. If this card becomes mislaid or lost please contact Lake County Stormwater Management Commission for a replacement.

Lake County Stormwater Management Commission (847) 377-7700



REPLY TO
ATTENTION OF:

DEPARTMENT OF THE ARMY
CHICAGO DISTRICT, CORPS OF ENGINEERS
231 SOUTH LA SALLE STREET
CHICAGO, ILLINOIS 60604-1437

February 7, 2017

Technical Services Division
Regulatory Branch
LRC-2016-00090

SUBJECT: Request Authorization to Impact 0.034 Acres of Wetland for the Weiland Road Improvements Project Located Woodstone Drive to IL Route 22 in the Village of Buffalo Grove, Lake County, Illinois

Thomas Somodji
Lake County Department of Transportation
600 West Winchester Road
Libertyville, IL 60048

Dear Mr. Somodji:

This office has verified that your proposed activity complies with the terms and conditions of Regional Permit 3 and the General Conditions for all activities authorized under the Regional Permit Program.

This verification expires three (3) years from the date of this letter and covers only your activity as described in your notification and as shown on the plans entitled "State of Illinois, Department of Transportation, Division of Highways Plan for Proposed Federal AID Highway, FAU RTE 2665 (Weiland Road) Woodstone Drive to IL Route 22, ADD LANES, BIKE/PED PATH AND INTERSECTION IMPROVEMENT SECTION, 07-00094-00-PV, PROJECT NO. XXX, Lake County, C-XX-XXX-XX, Sheets 1, 50, 55, 178, 182, 188, 208, 231, 544-547, 1182, 1183, 1270", dated November 23, 2015, prepared by Civil Tech. Caution must be taken to prevent construction materials and activities from impacting waters of the United States beyond the scope of this authorization. If you anticipate changing the design or location of the activity, you should contact this office to determine the need for further authorization.

The activity may be completed without further authorization from this office provided the activity is conducted in compliance with the terms and conditions of the RPP, including conditions of water quality certification issued under Section 401 of the Clean Water Act by the Illinois Environmental Protection Agency (IEPA). If the design, location, or purpose of the project is changed, you should contact this office to determine the need for further authorization.

1. This authorization is contingent upon implementing and maintaining soil erosion and sediment controls in a serviceable condition throughout the duration of the project. You shall comply with the Lake County Stormwater Management Commission (LCSMC)'s written and verbal recommendations regarding the soil erosion and sediment control

(SESC) plan and the installation and maintenance requirements of the SESC practices on-site.

- a. You shall schedule a preconstruction meeting with LCSMC to discuss the SESC plan and the installation and maintenance requirements of the SESC practices on the site. You shall contact the LCSMC at least 10 calendar days prior to the preconstruction meeting so that a representative may attend.
 - b. You shall notify the LCSMC or the LCSMC's designated agent of any changes or modifications to the approved plan set. Field conditions during project construction may require the implementation of additional SESC measures. If you fail to implement corrective measures, this office may require more frequent site inspections to ensure the installed SESC measures are acceptable.
 - c. Prior to commencement of any in-stream work, you shall submit construction plans and a detailed narrative disclosing the contractor's preferred method of cofferdam and dewatering method to the LCSMC or the LCSMC's designated agent. Work in the waterway shall NOT commence until the LCSMC notifies you, in writing, that the plans have been approved.
2. Under no circumstances shall the Contractor prolong final grading and shaping so that the entire project can be permanently seeded at one time. Permanent stabilization within the wetland and stream buffers identified in the plans shall be initiated immediately following the completion of work. Final stabilization of these areas should not be delayed due to utility work to be performed by others.
3. This site is within the aboriginal homelands of several American Indian Tribes. If any human remains, Native American cultural items or archaeological evidence are discovered during any phase of this project, interested Tribes request immediate consultation with the entity of jurisdiction for the location of discovery. In such case, please contact Melyssa R. Navis by telephone at (312) 846-5533, or email at melyssa.r.navis@usace.army.mil.
4. You are responsible for all work authorized herein and for ensuring that all contractors are aware of the terms and conditions of this authorization.
5. A copy of this authorization must be present at the project site during all phases of construction.
6. You shall notify this office of any proposed modifications to the project, including revisions to any of the plans or documents cited in this authorization. You must receive approval from this office before work affected by the proposed modification is performed.
7. You shall notify this office prior to the transfer of this authorization and liabilities associated with compliance with its terms and conditions.

The authorization is without force and effect until all other permits or authorizations from local, state, or other Federal agencies are secured. Please note that IEPA has issued Section 401 Water Quality Certification for this RP. These conditions are included in the enclosed fact sheet. If you have any questions regarding Section 401 certification, please contact Mr. Dan Heacock at IEPA's Division of Water Pollution Control, Permit Section #15, by telephone at (217) 782-3362.

Once you have completed the authorized activity, please sign and return the enclosed compliance certification. If you have any questions, please contact Melyssa R. Navis of my staff by telephone at (312) 846-5533, or email at melyssa.r.navis@usace.army.mil.

Sincerely,

Kathleen G. Chernich
Chief, East Section
Regulatory Branch

Enclosures

Copy Furnished:

Lake County Stormwater Management Commission (Kurt Woolford)
Lake County Planning, Building and Development Department (Matthew Meyers)
Civil Tech (Tom Liliensiek)

RAILROAD RIGHT OF ENTRY

This section includes the WCL/CN Special Provisions and requirements for working near, over, or under the railroad.

In addition to railroad protective liability insurance, any contractors working the WCL/CN right of way will need to apply for a right-of-entry permit and pay the \$1,000 fee. The prime contractor would apply for this permit and all subcontractors and subconsultants will be covered under the prime's policy and permit. This is only required in instances where the contract will require work on the WCL/CN right of way.

The contractor must contact the Wisconsin Central Limited Railroad Manager of Public Works at (708) 332-3557 at least 10 days prior to work start up to arrange for railroad flagging, protection, etc.

Method of Measurement. There will be no separate measurement or payment for fulfilling the requirements described herein, and all costs, direct or indirect, shall be included in the prices for other items.

It is the Contractor's sole responsibility to coordinate with the Wisconsin Central Ltd Railroad whenever construction activity is within 25 feet of the Railroad ROW. The Contractor shall retain flagmen employed and designated by the Wisconsin Central Ltd Railroad to monitor on-coming train traffic, and advise Contractor personnel when activity on or near the Railroad Right-of-Way may proceed. This item will be paid for according to article 107.12 and will be reimbursed according to article 109.05.



Manager Public Works

Paul Chojenski
17641 Ashland Avenue
Homewood, IL 60430

T 708.332.3557

F 708.332.3514

Email: Paul.Chojenski@cn.ca

Right of Entry (ROE) License Agreement Information

Railroad Company requires everyone (contractor, consultants, etc.) working on Railroad Company property to have a Right-of-Entry (ROE) License Agreement. No work may occur on Railroad Company property nor will flagging protection be provided until ROE License Agreement has been fully executed by both parties and returned.

Follow these steps to obtain a ROE:

1. Applicant will **Email** this completed application to paul.chojenski@cn.ca
2. Applicant will **mail** a check for the application fee \$1000.00* to the address listed at the end of this document
3. Applicant will **Email** a COI (Certificate of Insurance) meeting the requirements outlined in the Insurance requirements section of this document
4. Once steps 1-3 are completed, the Railroad Company will begin processing the ROE application
5. If approved, the Applicant will receive an electronic copy of the ROE agreement by email
6. Applicant will have the ROE agreement executed by Applicant's VP or president of Applicant's company
7. Applicant will return a **HARD COPY** of the partially executed ROE agreement by mail to the Railroad Company address listed at the end of this document
8. The Railroad Company will return a fully executed digital copy of the ROE License Agreement by email for the Applicants records.

Please use this form and return by email to submit application request for a Right of Entry agreement.

Contact name and Email address –

Name of Applicant/contractor and email address -

Street Address –

City, State, Zip –

Telephone –

Detailed Purpose for ROE –

Start and Completion Date of ROE –

Public Agency's Project No. –

Public Agency Easement No. (if known) –

Location of project –

Subdivision and Milepost –

FRA/AAR/DOT Crossing No. and Name –
(Nearest to jobsite)

If unable to locate this number at jobsite, please use following links to obtain:

<http://safetydata.fra.dot.gov/officeofsafety/publicsite/crossing/xingqryloc.aspx>

In Illinois

<http://www.icc.illinois.gov/railroad/advanced.aspx?>

Please attach an aerial snapshot and a Google Earth kmz file to help identify specific location.

FAQ

What time frame can I expect to begin work and have flagging protection for my work?

A **Right of Entry License Agreement usually takes 4 to 6 weeks to obtain**. Once you have a fully executed ROE agreement, you will receive a flagging request form. This flagging request form along with prepayment for flagging fees will need to be *mailed to the physical address listed on the flagging request form*. Once this flagging request form is received, it is usually about **10 days until a flagger can be scheduled**. These are normal time frames. **Time frames can vary substantially** based on many factors. Expedited time frames may be able to be requested at an additional fee.

A brief summary of time frame for each step toward obtaining flagging protection...

1. Right of Entry License Agreement usually takes **4 to 6 weeks to obtain**.
2. Send in flagging check and flagging request form...about **1 week**
3. Once this flagging request form is received, it is usually about **10 days** until a flagger can be scheduled

What are the insurance requirements?

Railroad Company allows outside parties to come onto Railroad Company property to perform work, such as survey or inspection work, installation of pipelines and wirelines, and other work for projects necessitating the occupancy of Railroad Company. Before commencing work, and until the license of allowing such occupancy ends or is terminated, outside parties shall provide and maintain the following insurance in form and amount with companies satisfactory to and as approved by Railroad Company.

1. Minimum insurance required of outside party:
 - A. Statutory Workers Compensation and Employer's Liability Insurance.
 - B. Automobile Liability Insurance in an amount not less than \$1,000,000 combined single limit.
 - C. Commercial General Liability Insurance (Occurrence Form) in an amount not less than **\$5,000,000 per occurrence, with an aggregate limit of not less than \$10,000,000**. The policy must name Railroad Company and its Parents as additional insureds in the following form:

Wisconsin Central Ltd. Company and its Parents
Attn: Paul Chojenski
17641 South Ashland Avenue
Homewood, IL 60430
(708) 332-3557 (office)
Paul.Chojenski@cn.ca

The policy must remove any provisions excluding coverage for injury, loss or damage arising out of or resulting from doing business or undertaking construction or demolition on, near, or adjacent to railroad track or facilities using endorsement CG 2417 10 01 or equivalent approved by Railroad Company.

- D. When outside party is required by Railroad Company or Governing Authority to purchase Railroad Protective Liability Insurance to cover work on, near or adjacent to railroad track or facilities, and outside party is not being hired for this project by Railroad Company, outside party must procure Railroad Protective Liability Insurance in the following form;

This coverage shall be written on an Occurrence Form with limits of not less than \$5,000,000 per occurrence for Bodily Injury, Personal Injury and Physical Damage to Property, with an aggregate limit of not less than \$10,000,000. The policy must name:

Wisconsin Central Ltd. Company and its Parents
Attn: Paul Chojenski
17641 South Ashland Avenue
Homewood, IL 60430
(708) 332-3557 (office)
Paul.Chojenski@cn.ca

- E. In the event the privileges provided herein to Applicant involve any work that could result in the discharge, spillage, disposal, release or escape of any Hazardous Material or petroleum product onto the Railroad Company's property, Applicant shall purchase and maintain in effect at all times during the term of this License a Contractor's Pollution Liability policy in an amount not less than two million dollars (\$2,000,000) combined single limit (and with a deductible not to exceed \$50,000) insuring Railroad against any and all damages, costs, liabilities and expenses resulting from on- or off-site bodily injury (including death to any person), on or off-site loss, damage or destruction of property (including that belonging to the parties hereto), and on-or off-site cleanup costs (including expenses incurred in the investigation, removal, remediation, neutralization, or immobilization of contaminated soils, surface water, groundwater or any other contamination) growing out of or incidental to any discharge, spillage, disposal, release, or escape of any Hazardous Material or petroleum product arising therefrom. For purposes of this Agreement, the term "Hazardous Material" shall include, without limit, any flammable explosives, radioactive materials, hazardous materials, hazardous wastes, hazardous or toxic substances, or related materials defined in the Comprehensive Environmental Response, Compensation and Liability Act of 1980, as amended (42 U.S.C. §§ 9601, et seq.), the Hazardous Material Transportation Act, as amended (49 U.S.C. §§ 1801, et seq.), the Resource Conservation and Recovery Act, as amended (42 U.S.C. §§ 6901 et seq.), the Toxic Substances Control Act, as amended (15 U.S.C. §§ 2601, et seq.), similar laws or ordinances enacted by any state, county or municipality in which the Property is located, or in the regulations adopted and publications promulgated pursuant to any of the above, as such laws or regulations now exist or may exist in the future.

Applicant is required to advise Railroad Company by thirty (30) day advance written notice when any work to be performed under this License may require Pollution Liability Insurance pursuant to the previous paragraph.

- F. All policies described above must include description of operations, Railroad Company milepost, highway or street name, city and state of location, project number, and Railroad Company contact person on the certificate.
2. Before commencing work, outside party shall deliver to Railroad Company a certificate of insurance evidencing the foregoing coverages and, if requested by Railroad Company, true and complete copies of the policies described above. If the policy is being issued in conjunction with, or as a result of, a city, county or state contract, the policy should be initially submitted to the respective city, county or state agency that will review it first and then forward it to Railroad Company.
3. Common Policy Provisions. Each policy described in paragraph 1, parts A through E above, must include the following provisions:
- A. Each policy shall include a waiver by the insurer of any right of subrogation against any recovery by or on behalf of any insured.
- B. Each policy shall provide for not less than thirty (30) days prior written notice to Railroad Company at the address listed above of cancellation of or any material change in that policy.

4. It is understood and agreed that the foregoing insurance coverage requirements, and outside party's compliance with those requirements, is not intended to, and shall not, relieve outside party from, or serve to limit, outside party's liability and indemnity obligations under the provisions herein.
5. Railroad Company shall have the right, from time to time, to revise the amount or form of insurance coverage required as circumstances or changing economic conditions may require. Railroad Company shall give outside party written notice of any such requested change at least thirty (30) days before the date of expiration of the then-existing policy or policies, outside party agrees to, and shall, thereupon provide Railroad Company with such revised policy or policies.
6. Insurance required of SUBCONTRACTOR:
 - A. If a SUBCONTRACTOR is to be employed by outside party to perform work on Railroad Company under or by the permission for occupancy granted to outside party by Railroad Company, before commencing work, the SUBCONTRACTOR shall provide and thereafter maintain all of the insurance described in paragraph 1, parts A through E, above, in the same forms and amounts as provided for above and subject to the other terms and conditions provided for in paragraphs 2 through 4 above.
 - B. In the alternative, before the SUBCONTRACTOR commences work for outside party on Railroad Company, outside party may provide and thereafter maintain all of the insurance described in paragraph 1, parts A through E, above, in the same forms and amounts as provided for above and subject to the other terms and conditions provided for in paragraphs 2 through 5 above, provided that all such insurance names SUBCONTRACTOR as an additional insured and all such insurance provides coverage to all additional insureds, including Railroad Company, for any liability arising out of work performed by all other additional insureds, including SUBCONTRACTOR.

Is safety training required?

Prior to any entry onto Railroad Company's property, the employees and/or subcontractors of a Contractor, Grantee, Licensee, or Permittee shall determine by the guidelines hereinafter provided and by the work to be performed the level of safety training to be required.

All employees and/or subcontractors of a Contractor, Grantee, Licensee, or Permittee not hired by Railroad Company that will work on CN property are required to have minimum www.contractororientation.com.

- a. EXCEPTION: Railroad Company has exempted those it classifies as "Delivery Persons" from this training. This will include contractors such as UPS, FedEx, trucking companies, etc. who merely access the property to supply materials or equipment.

All employees and/or subcontractors of a Contractor, Grantee, Licensee, or Permittee hired by Railroad Company which will work on Railroad Company property are required to have minimum CN Safety and Security Awareness training, in addition to undergoing a background check. This training and background check must be obtained through the eRailSafe.com website. If not done before, the contractor must contact e-RailSafe at 855-383-7434 to be issued either a vendor number or issued instructions on obtaining a non –railroad contractor vendor number prior to accessing the noted website. Minimum information required of a Contractor, Grantee, Licensee, or Permittee and/or their subcontractor when contacting e-RailSafe is Name, Address, Telephone, Contact Person for State Projects, DOT Contract Number, and the AAR/DOT Number. This training is good for a period of two years.

- a. EXCEPTION: Railroad Company has exempted those employees of contractors providing paving services at a road crossing under construction or repair from this requirement.
- b. EXCEPTION: Railroad Company has exempted those it classifies as "Delivery Persons" from this training. This will include contractors such as UPS, FedEx, trucking companies, etc. who merely access the property to supply materials or equipment.

All employees and/or subcontractors of a Contractor, Grantee, Licensee, or Permittee hired by Railroad Company, whose duties include and who are engaged in the inspection, construction, maintenance, or repair of railroad track, bridges, roadway, signal and communication systems, roadway facilities, or roadway machinery that will work foul of or have the potential to foul a live track are considered Roadway Workers under FRA regulations and CN Policy. They must complete the On-Track Safety Training course approved by Railroad Company and provided by R.R. Safety – AMR, P.O. Box 75, Lomira, WI 53048, telephone (920) 517-1677, email rrsafetytraining@yahoo.com. This training must be repeated at least once each calendar year.

- a. EXCEPTION: Railroad Company has exempted those employees of contractors providing paving services at a road crossing under construction or repair from this requirement.
- b. EXCEPTION: Railroad Company has exempted those it classifies as "Delivery Persons" from this training. This will include contractors such as UPS, FedEx, trucking companies, etc. who merely access the property to supply materials or equipment.
- c. All the employees and/or subcontractors of a Contractor, Grantee, Licensee, or Permittee who will operate on-track machinery or those who will provide protection for other employees and/or subcontractors of a Contractor, Grantee, Licensee, or Permittee must also be trained on CN US Operating Rules pertaining to their duties. They must take and pass the required examination. This training is good for a period of two years.
- d. "Potential to foul a live track" is considered, at a minimum, to be working within twenty-five (25) feet of the track; or as otherwise to be determined by CN Design & Construction Department.

The employees, subcontractors, and/or agents of the Licensee and/or its contractor shall qualify for, and make available for inspection to Railroad Company's employees or other authorized personnel at all times while on Railroad Company property, a photo identification issued by www.e-railsafe.com, along with at least one other government-issued form of identification. Licensee and/or their contractor shall bear all costs of compliance with the requirements of this Section. Railroad Company reserves the right to bar any of employees or agents of a Contractor, Grantee, Licensee, or Permittee and/or their contractor from Railroad Company's property at any time for any reason.

What are the costs and address to mail documents and ROE application fee check?

Application Fee Information:

Cost is \$1000.00* for application

*Fee may be increased for special handling, expedited handling, or multiple reviews.

Check Payable To: Wisconsin Central Ltd. Company
Mail To: Chicago, Central & Pacific Railroad Company
Attn: Paul Chojenski
17641 South Ashland Ave
Homewood, IL 60430

Mailing Address Information:

Mail To: Wisconsin Central Ltd. Company
Attn: Paul Chojenski
17641 South Ashland Ave
Homewood, IL 60430

Flagging Protection Rates:

Basic daily rate – = \$1,300.00 per day
Monday thru Friday regular business hours
Includes 8 standard rate hours and 2 OT hours to set flags
Overtime rate – = \$150.00 per hour
hours in excess of 8 hours or outside of regular business hours
Weekend or holiday rate - = \$1,500.00 per day
\$150.00 per hour with a 10 hour minimum

Email the completed first page above to: Paul.Chojenski@cn.ca

Revised 11-07-2016

SPECIAL PROVISIONS

RELATIVE TO FLAGGING AND OTHER PROTECTION OF RAILROAD COMPANY TRAFFIC AND FACILITIES DURING CONSTRUCTION ADJACENT AND ABOVE, ON OR ACROSS, THE PROPERTY OF, OR ON, ABOVE AND BENEATH THE TRACKS OF THE WISCONSIN CENTRAL LTD.

The Grantee, Licensee, Permittee and/or its Contractor shall, before entering upon the property of Railroad Company for performance of any work, secure a fully executed right of entry license from Railroad Company's Engineering Manager or their authorized representative for the occupancy and use of Railroad Company's property. Grantee, Licensee, Permittee and/or its Contractor and/or subcontractor(s) shall confer with Railroad Company relative to requirements for railroad clearances, operation and general safety regulations.

Prior to any entry onto Railroad Company's property, employees and/or subcontractors of Grantee, Licensee, Permittee and/or its Contractor doing work shall determine by the guidelines hereinafter provided and by the work to be performed the level of safety training to be required.

All employees and/or subcontractors of Grantee, Licensee, Permittee and/or its Contractor not hired by Railroad Company that will work on CN property are required to have minimum www.contractororientation.com.

- a. EXCEPTION: Railroad Company has exempted those it classifies as "Delivery Persons" from this training. This will include contractors such as UPS, FedEx, trucking companies, etc. who merely access the property to supply materials or equipment.

All employees and/or subcontractors of Grantee, Licensee, Permittee and/or its Contractor hired by Railroad Company which will work on Railroad Company property are required to have minimum CN Safety and Security Awareness training, in addition to undergoing a background check. This training and background check must be obtained through the eRailSafe.com website. If not done before, the contractor must contact CN Special Agent James Conroy at 708-332-5947 or James.Conroy@cn.ca to be issued a vendor number prior to accessing the noted website. Minimum information required of the Grantee, Licensee, Permittee and/or its Contractor and/or subcontractor(s) when contacting either Special Agent James Conroy or e-RailSafe is Name, Address, Telephone, Contact Person for State Projects, DOT Contract Number, and the AAR/DOT Number. This training is good for a period of two years.

- a. EXCEPTION: Railroad Company has exempted those employees of contractors providing paving services at a road crossing under construction or repair from this requirement.
- b. EXCEPTION: Railroad Company has exempted those it classifies as "Delivery Persons" from this training. This will include contractors such as UPS, FedEx, trucking companies, etc. who merely access the property to supply materials or equipment.

All employees and/or subcontractors of Grantee, Licensee, Permittee and/or its Contractor hired by Railroad Company, whose duties include and who are engaged in the inspection, construction, maintenance, or repair of railroad track, bridges, roadway, signal and communication systems, roadway facilities, or roadway machinery that will work foul of or have the potential to foul a live track are considered Roadway Workers under FRA regulations and CN Policy. They must complete the On-Track Safety Training course approved by Railroad Company and provided by R.R. Safety – AMR, P.O. Box 75, Lomira, WI 53048,

telephone (920) 517-1677, email rrsafetytraining@yahoo.com. This training must be repeated at least once each calendar year.

- a. EXCEPTION: Railroad Company has exempted those employees of contractors providing paving services at a road crossing under construction or repair from this requirement.
- b. EXCEPTION: Railroad Company has exempted those it classifies as “Delivery Persons” from this training. This will include contractors such as UPS, FedEx, trucking companies, etc. who merely access the property to supply materials or equipment.
- c. All the employees and/or subcontractors of Grantee, Licensee, Permittee and/or its Contractor who will operate on-track machinery or those who will provide protection for other employees and/or subcontractors of Grantee, Licensee, Permittee and/or its Contractor must also be trained on CN US Operating Rules pertaining to their duties. They must take and pass the required examination. This training is good for a period of two years.
- d. “Potential to foul a live track” is considered, at a minimum, to be working within twenty-five feet of the track; or as otherwise to be determined by CN Design & Construction Department.

The employees, subcontractors, and/or agents of the Grantee, Licensee, Permittee and/or its Contractor shall qualify for, and make available for inspection to Railroad Company's employees or other authorized personnel at all times while on Railroad Company property, a photo identification issued by www.e-railsafe.com, along with at least one other government-issued form of identification. Grantee, Licensee, Permittee and/or its Contractor and/or subcontractor(s) shall bear all costs of compliance with the requirements of this Section. Railroad Company reserves the right to bar any of employees or agents of Grantee, Licensee, Permittee and/or its Contractor and/or subcontractor(s) from Railroad Company's property at any time for any reason.

Grantee, Licensee, Permittee and/or its Contractor and/or any contractor engaged on their behalf, shall at all times conduct work in a manner satisfactory to the Engineering Manager of Railroad Company, or their authorized representative, and shall exercise care so as to not damage the property of Railroad Company, or that belonging to any other grantees, licensees, permittees or tenants of Railroad Company, or to interfere with railroad operations.

Engineering Manager of Railroad Company, or their authorized representative, will at all times have jurisdiction over the safety of railroad operations., The decision of the Engineering Manager or their authorized representative as to procedures which may affect the safety of railroad operations shall be final, and Grantee, Licensee, Permittee and/or its Contractor and/or subcontractor(s) shall be governed by such decision.

All work shall be conducted in such a manner as will assure the safety of Railroad Company. Railroad Company's authorized representative shall have the right, but not the duty, to require certain procedures to be used or to supervise the work on Railroad Company's property.

Should any damage occur to Railroad Company property as a result of the authorized or unauthorized operations of Grantee, Licensee, Permittee and/or its Contractor and/or subcontractor(s) and Railroad Company deems it necessary to repair such damage or perform any work for the protection of its property or operations, the Grantee, Licensee, Permittee and/or its Contractor, as the case may be, shall promptly reimburse Railroad Company for the actual cost of such repairs or work. For the purpose of these

Special Provisions, actual cost shall be deemed to include the direct cost of any labor, materials, equipment, or contract expense plus Railroad Company's current standard additives in each instance.

If the work requires the construction of a temporary grade crossing across the track(s) of Railroad Company, Grantee, Licensee, Permittee and/or its Contractor and/or subcontractor(s) shall make the necessary arrangements and execute Railroad Company's temporary grade crossing agreement for the construction, protection, maintenance, and later removal of such temporary grade crossing. The cost of such temporary grade crossing construction and later removal shall be prepaid to Railroad Company. Additional costs for repairs, maintenance or protection will be paid within thirty (30) days upon receipt of bill(s) therefor.

Grantee, Licensee, Permittee and/or its Contractor and/or subcontractor(s) shall at no time cross Railroad Company's property or tracks with vehicles or equipment of any kind or character, except at such temporary grade crossing as may be constructed as outlined herein, or at any existing and open public grade crossing. Operation over such crossing shall be at the direction and method of Railroad Company's Engineering Manager or their authorized representative.

Railroad Company may, at Grantee's, Licensee's, Permittee's and/or its Contractor's and/or their contractor's sole cost, risk and expense, furnish whatever protective services it considers necessary, including, but not limited to, flagger(s), inspector(s), and stand-by personnel. Flagging protection, inspection services, or standby personnel required by Railroad Company for the safety of railroad operations because of work being conducted by Grantee, Licensee, Permittee and/or its Contractor, or in connection therewith, will be provided by Railroad Company and the cost of Grantee, Licensee, Permittee and/or its Contractor and shall be prepaid to Railroad Company by Grantee, Licensee, Permittee and/or its Contractor. Flagging protection, inspection services, or standby personnel, necessary or provided in excess of prepayment amounts will be billed at the proper rates and will be promptly paid by overnight delivery.

In the event Railroad Company is unable to furnish protective services at the desired time or on the desired date(s), or if Grantee's, Licensee's, Permittee's and/or its Contractor's prepayment for such services is exhausted and not replenished by Grantee, Licensee, Permittee and/or its Contractor, Grantee, Licensee, Permittee and/or its Contractor and/or subcontractor(s) shall not perform any work on Railroad Company's property until such time and date(s) that appropriate Railroad Company services can be made available and/or appropriate prepayment is received. It is understood that Railroad Company shall not be liable for any delay or increased costs incurred by Grantee, Licensee, Permittee and/or its Contractor and/or subcontractor(s) owing to Railroad Company's inability or failure to have appropriate protective services available at the time or on the date requested.

Grantee, Licensee, Permittee and/or its Contractor and/or subcontractor(s) shall request and secure flagging protection by written notice to Railroad Company using CN's "Request for Flagging Services" form. This form must be submitted at least ten (10) working days in advance of proposed performance of any work or access to Railroad Company's property.

Flagging protection will be required during any operation involving direct and potential interference with Railroad Company's tracks or traffic. This may include but is not limited to fouling of railroad operating clearances, reasonable proximity of accidental hazard to railroad traffic, work within twenty-five (25) feet horizontally of the nearest centerline of any railroad track, any work over any railroad track, or in any other condition that Railroad Company deems protective services necessary, which may include work on or off Railroad Company's property more than twenty-five (25) feet from the nearest centerline of any railroad track, such as any equipment extension (including but not limited to a crane boom) that will reach or has the potential to reach within twenty-five (25) feet of any track.

Grantee, Licensee, Permittee and/or its Contractor and/or subcontractor(s) shall request, prepay, and secure Railroad Company signal facility locates by written notice to Railroad Company along with submission of CN's "Request for Flagging Services" form at least ten (10) working days in advance of proposed performance of any work or access to Railroad Company property. Notice to Railroad Company does not fulfill or satisfy any other notification requirements for utility locates for non-railroad facilities.

Railroad Company may require that prior to digging, trenching, or boring activities on or near Railroad Company property, or beneath any railroad track, an on-site meeting be conducted with Railroad Company's Signal Department representative. No digging, trenching or boring activities shall be conducted in the proximity of any known buried Railroad Company signal cables without Railroad Company's Signal Department representative being present.

The rate of pay for Railroad Company employees will be the prevailing hourly rate for not less than eight (8) hours for the class of labor at regular rates during regularly assigned work hours, and at overtime rates outside of regular hours and in accordance with Labor Agreements or Schedules plus Railroad Company's current standard additives in each instance.

Wage rates are subject to change, at any time, by law or agreement between Railroad Company and employees, and may be retroactive because of negotiations or a ruling by an authorized Governmental Agent. If the wage rates are changed, Grantee, Licensee, Permittee and/or its Contractor and/or subcontractor(s) shall pay on the basis of the new rates and/or additives.

No digging, trenching, or boring on Railroad Company property shall be conducted without Railroad Company's written approval of the plans that were furnished to Railroad Company's Engineering Manager at least thirty (30) in advance of the excavation.

The following temporary clearances are the minimum that must be maintained at all times during any operation on or adjacent to Railroad Company property:

Vertical: 22'-0" (7.00 m) above top of highest rail within 12'-0" (3.81 m) of the centerline of any track

Horizontal: 12'-0" (3.81 m) from centerline of the nearest track, measured at right angles thereto

If lesser clearances than the above are required for any part of the work, Grantee, Licensee, Permittee and/or its Contractor and/or subcontractor(s) shall secure written authorization from Railroad Company's Engineering Manager for such lesser clearances in advance of the start of that portion of the work.

No materials, supplies, or equipment will be stored within twenty-five (25) feet from the centerline of any railroad track, measured at right angles thereto.

Grantee, Licensee, Permittee and/or its Contractor and/or subcontractor(s) will be required upon the completion of the work to remove from within the limits of Railroad Company's property all machinery, equipment, surplus materials, false work, rubbish or temporary buildings, and to leave said property in a condition satisfactory to the Engineering Manager of Railroad Company or their authorized representative.

Nothing in these Special Provisions shall be construed to place any responsibility on Railroad Company for the quality or conduct of the work performed by Grantee, Licensee, Permittee and/or its Contractor and/or subcontractor(s) hereunder. Any approval given or supervision exercised by Railroad Company hereunder, or failure of Railroad Company to object to any work done, material used, or method

of operation shall not be construed to relieve Grantee, Licensee, Permittee and/or its Contractor and/or subcontractor(s) and/or subcontractor of any obligations pursuant hereto or under the License these Special Provisions are appended to.



A Subsidiary of GZA

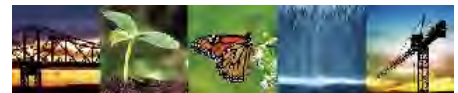

To: Reid T. Magner, P.E. – Civiltech Engineering, Inc.
 From: Jeremy J. Reynolds, P.G.
 Date: October 17, 2017
 Re: CCDD LPC-663 Form – Weiland Road Improvements

GEOTECHNICAL

ENVIRONMENTAL

ECOLOGICAL

WATER

CONSTRUCTION
MANAGEMENT

915 Harger Road
 Suite 330
 Oak Brook, IL 60523
 T: 630.684.9100
 F: 630.684.9120
 www.huffnhuff.com
 www.gza.com

Huff & Huff, Inc. (H&H) provided services in support of a Form LPC-663 for Stages I, III, and IV of the Weiland Road Improvement Project. Based on a 2012 Preliminary Environmental Site Assessment (PESA), and additional due diligence performed by H&H, 8 sites were identified as Potentially Impacted Properties (PIPs) in relation to this portion of the Project Corridor. As PIPs were identified, completion of Uncontaminated Soil Certification by Licensed Professional Engineer or Geologist (LPC-663) is appropriate for acceptance of excavated spoils as *uncontaminated soil* at a Clean Construction and Demolition Debris (CCDD) facility or Uncontaminated Soil Fill Operation (USFO).

A Preliminary Site Investigation (PSI) of the Project Corridor was performed by H&H in August 2017, and soil samples were collected for analyses in support of Form LPC-663. Twenty-seven (27) soil borings were advanced within the Stage I, III, and IV Project Corridor based on potential impacts associated with the eight (8) identified PIPs. Soils were screened in the field using a photoionization detector (PID) and representative soil samples were collected and analyzed for contaminants of concern (COCs) associated with the PIPs, including VOCs, BTEX, PNAs, RCRA metals, pesticides, and herbicides. In addition, the soil was tested for pH to provide a full characterization of the Project Corridor for soil management purposes.

Analytical results achieved at maximum allowable concentrations (MACs), and the soil pH results ranged from 7.03 to 8.50, within the soil pH requirement for CCDD disposal (between 6.25 and 9.0). Based on the findings contained within this document, soils achieve the CCDD requirements and are certified for disposal using the attached Form LPC-663. Refer to the attached narrative for a full description of the Project Corridor, identified sites, and analytical testing.

However, soils within the CN Railway ROW are precluded from acceptance at CCDD facilities or USFOs, as they could not be assessed during the PSI. Soils generated from this area are NOT certified for CCDD disposal, and if design cannot avoid these soils or reuse them within the Project Corridor, they require disposal at a subtitle D sanitary landfill or analytical testing for CCDD characterization.

Should conditions within the Project Area differ from those encountered in the Preliminary Site Investigation, such as unusual staining, odors, or if loads become rejected, additional analytical assessment may be required for final disposition of spoils from this Project Area. If you have any questions regarding this matter, please contact us at 630-684-9100.

Jeremy J. Reynolds, P.G.
 Associate Principal



Bureau of Land • 1021 North Grand Avenue East • P.O. Box 19276 • Springfield • Illinois • 62794-9276

Uncontaminated Soil Certification by Licensed Professional Engineer or Licensed Professional Geologist for Use of Uncontaminated Soil as Fill in a CCDD or Uncontaminated Soil Fill Operation LPC-663

Revised in accordance with 35 Ill. Adm. Code 1100, as amended by PCB R2012-009 (eff. Aug. 27, 2012)

This certification form is to be used by professional engineers and professional geologists to certify, pursuant to 35 Ill. Adm. Code 1100.205(a)(1)(B), that soil (i) is uncontaminated soil and (ii) is within a pH range of 6.26 to 9.0. If you have questions about this form, please telephone the Bureau of Land Permit Section at 217/524-3300.

This form may be completed online, saved locally, printed and signed, and submitted to prospective clean construction or demolition debris (CCDD) fill operations or uncontaminated soil fill operations.

I. Source Location Information

(Describe the location of the source of the uncontaminated soil)

Project Name: Weiland Road Improvements Office Phone Number, if available: 847-377-7400

Physical Site Location (address, including number and street):

Weiland Rd (N of Deerfield Pkwy) from Cobble Ln to Aptakisic Rd & Prairie Rd from Aptakisic Rd to Half Day Rd

City: Buffalo Grove State: IL Zip Code: 60089

County: Lake Township: Vernon

Lat/Long of approximate center of site in decimal degrees (DD.ddddd) to five decimal places (e.g., 40.67890, -90.12345):

Latitude: 42.18264 Longitude: -87.94893

(Decimal Degrees) (-Decimal Degrees)

Identify how the lat/long data were determined:

GPS Map Interpolation Photo Interpolation Survey Other

ISGS Public Land Survey System, lat/long refers to the approximate center of the Project Corridor

IEPA Site Number(s), if assigned: BOL: _____ BOW: _____ BOA: _____

II. Owner/Operator Information for Source Site

Site Owner

Site Operator

Name: Lake County Division of Transportation

Name: Lake County Division of Transportation

Street Address: 600 W. Winchester Road

Street Address: 600 W. Winchester Road

PO Box: _____

PO Box: _____

City: Libertyville State: IL

City: Libertyville State: IL

Zip Code: 60048-1381 Phone: 847-377-7400

Zip Code: 60048-1381 Phone: 847-377-7400

Contact: Thomas Somodji - Project Manager

Contact: Thomas Somodji - Project Manager

Email, if available: TSomodji@lakecountyil.gov

Email, if available: TSomodji@lakecountyil.gov

This Agency is authorized to require this information under Section 4 and Title X of the Environmental Protection Act (415 ILCS 5/4, 5/39). Failure to disclose this information may result in: a civil penalty of not to exceed \$50,000 for the violation and an additional civil penalty of not to exceed \$10,000 for each day during which the violation continues (415 ILCS 5/42). This form has been approved by the Forms Management Center.

Project Name: Weiland Road Improvements

Latitude: 42.18264 Longitude: -87.94893

Uncontaminated Site Certification

III. Basis for Certification and Attachments

For each item listed below, reference the attachments to this form that provide the required information.

- a. A Description of the soil sample points and how they were determined to be sufficient in number and appropriately located 35 Ill. Adm. Code 1100.610(a):

Based on review of a PESA (May 2012), and due diligence by H&H in 2017, 8 PIPs were identified in relation to the portion of the Project Corridor (N. of Deerfield Pkwy) represented by this 663 Form. 27 borings were advanced to identify potential impacts associated with the PIPs and characterize soils for soil management. See attached narrative for further details.

- b. Analytical soil testing results to show that soil chemical constituents comply with the maximum allowable concentrations established pursuant to 35 Ill. Adm. Code Part 1100, Subpart F and that the soil pH is within the range of 6.25 to 9.0, including the documentation of chain of custody control, a copy of the lab analysis; the accreditation status of the laboratory performing the analysis; and certification by an authorized agent of the laboratory that the analysis has been performed in accordance with the Agency's rules for the accreditation of environmental and the scope of the accreditation [35 Ill. Adm. Code 1100.201(g), 1100.205(a), 1100.610]:

Soil samples were continuously screened with a PID and select samples were analyzed for one or more of the following: VOCs, BTEX, PNAs, RCRA metals, pesticides, herbicides, and pH. All soil results achieved their MACs, and pH ranged from 7.03 to 8.50, within the CCDD requirement. See attached narrative for further details and discussion on a CCDD exclusion zone.

IV. Certification Statement, Signature and Seal of Licensed Professional Engineer or Licensed Professional Geologist

I, Jeremy J. Reynolds, P.G. (name of licensed professional engineer or geologist) certify under penalty of law that the information submitted, including but not limited to, all attachments and other information, is to the best of my knowledge and belief, true, accurate and complete. In accordance with the Environmental Protection Act [415 ILCS 5/22.51 or 22.51a] and 35 Ill. Adm. Code 1100.205(a), I certify that the soil from this site is uncontaminated soil. I also certify that the soil pH is within the range of 6.25 to 9.0. In addition, I certify that the soil has not been removed from the site as part of a cleanup or removal of contaminants. All necessary documentation is attached.

Any person who knowingly makes a false, fictitious, or fraudulent material statement, orally or in writing, to the Illinois EPA commits a Class 4 felony. A second or subsequent offense after conviction is a Class 3 felony. (415 ILCS 5/44(h))

Company Name: Huff & Huff, Inc. A Subsidiary of GZA GeoEnvironmental, Inc.
 Street Address: 915 Harger Road, Suite 330
 City: Oak Brook State: IL Zip Code: 60523
 Phone: 630-684-4406

Jeremy J. Reynolds, P.G.
 Printed Name:

[Signature]
 Licensed Professional Engineer or
 Licensed Professional Geologist Signature:

10/17/17
 Date:

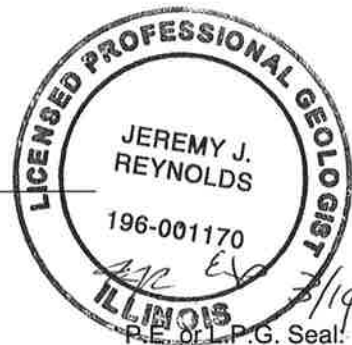



Uncontaminated Soil Certification

by Licensed Professional Engineer or Licensed Professional Geologist for Use of Uncontaminated Soil as Fill in a CCDD or Uncontaminated Soil Fill Operation.

LPC-663

Owner: Lake County DOT

Project Name: Weiland Road Improvements – Stage I, III, and IV Corridor

III. Basis for Certification and Attachments

Explain the basis upon which you are certifying that the soil from this site is uncontaminated soil.

This form pertains to soils generated from a portion (Stages I, III, and IV) of the Weiland Road Improvement Project. Specifically, the portion of the Project Corridor includes proposed improvements along Weiland Road, north of Deerfield Parkway, and Prairie Road, with limits extending from Cobble Lane to Half Day Road (663 Corridor). The 663 Corridor also includes proposed acquisition of Right-of-Way (ROW) and easements for detention basin construction and a to-be-constructed roadway connecting Weiland Road to Prairie Road. The northern portion (north of Aptakisic Road) of the 663 Corridor is located within a residential neighborhood in Prairie View, IL. The southern portion of the 663 Corridor (south of Aptakisic Road) is located within a mix of residential, commercial, and industrial land use and is located within three different towns: Prairie View, Buffalo Grove, and Lincolnshire. The latitude/longitude (decimal degrees) at the approximate center of the Project Area is 42.18264 / -87.94893. Proposed improvements consist of roadway reconstruction, detention basin construction, sewer and drainage improvements, sidewalk installation, street lighting improvements, and retaining wall installation. The maximum depth up excavation is anticipated to be approximately 16 feet below ground surface (bgs).

It should be noted that the remaining portion of the Weiland Road Improvements Project Corridor (Project Corridor), which includes an approximate 4,700-foot section of Weiland Road south of Deerfield Parkway (662 Corridor), is included under a separate LPC-662 Form due to lack of PIPs associated with that portion of the Project Corridor.

Refer to **Attachment A** for maps depicting the Project Corridor, 663 Corridor, potentially impacted properties (PIPs), and soil boring locations. A map depicting the 662 Corridor has also been included in **Attachment A** for reference. Refer to **Attachment B** for a photo log of the 663 Corridor.

Due Diligence

A Preliminary Environmental Site Assessment (PESA) was conducted in May 2012 for the Project Corridor by Cardno ENTRIX, Inc. and ATC Associates, Inc. The PESA report is included in **Attachment C (on CD)** and includes a description of the Project Corridor, the screening process, and the identified sites. Based on a review of database records, historical resources, and site reconnaissance, seven (7) Recognized Environmental Conditions (RECs) were identified in relation to the Project Corridor of high or medium risk. Huff & Huff, Inc. (H&H) reviewed the information provided in the PESA, and confirmed the 7 RECs to be PIPs in relation to the Project Corridor. All further discussion within this document refers to the identified RECs as PIPs. It is important to note all seven (7) PIPs are located north of Deerfield Parkway, within the project limits for this 663-Form.



In addition, H&H conducted site reconnaissance activities on August 2, 2017 to inspect the Project Corridor for indications of potential environmental concern, such as spills, staining, storage of hazardous materials, and stressed vegetation. During the site reconnaissance, H&H identified the Canadian National (CN) Railway adjacent to the Project Corridor. The CN Railway is considered a PIP in relation to the Project Corridor. The CN Railway is also located north of Deerfield Parkway and is within the project limits for this 663-Form.

The eight (8) identified PIPs are summarized in the following table. The locations of the PIPs are depicted on a figure included in **Attachment A**.

Summary of Potentially Impacted Properties

Site Name	Address	Reason(s)
Aptakistic Junior High School ¹	1231 North Weiland Road, Buffalo Grove, IL	UST, LUST – Known Fuel Oil Release
Weiland Partnership ¹	21555 North Weiland Road, Buffalo Grove, IL	RCRA NON GEN, UST, LUST – Known Fuel Oil Release
Single-Family Residences ¹	16154-16202 West Aptakistic Road, Lincolnshire, IL	Poor Housekeeping – 55-Gallon Drums, Various Debris, Vehicle Parts, etc.
Residential Property ¹	16226 West Aptakistic Road, Lincolnshire, IL	Chemical Use Historically Associated with the Automotive Industry; Poor Housekeeping – Junk Yard with Vehicles, Automotive Parts, and Machinery.
American Pet Hotel ¹	22096 North Pet Lane, Prairie View, IL	Potential Contamination Associated with Use of a Septic Tank Leach Field
Rolling Hills Nursery ¹	22149 North Pet Lane, Prairie View, IL	Pesticide/Herbicide Use Historically Associated with Nurseries; Oil-Stained Soil On Site
Wooded Land ¹	22825 North Prairie Road, Prairie View, IL	Empty 800-Gallon AST; Oil Sheen Observed in On-Site Pond
CN Railway ²	Intersection at Aptakistic Road, Lincolnshire, IL	Pesticide/Herbicide Use Historically Associated with Railroad Tracks

¹Site identified in the May 2012 PESA conducted by Cardno ENTRIX, Inc. and ATC Associates, Inc.

²Site identified by H&H during August 2017 site reconnaissance.

A summary of each site, as described in the PESA report (except for the CN Railway), is presented below. Refer to the PESA report in **Attachment C** for further details.

Aptakistic Junior High School

The property was identified as a Facility Index System (FINDS), Underground Storage Tank (UST), and Leaking Underground Storage Tank (LUST) facility. According to the database report, one (1) 2,000-gallon heating oil UST was removed from the property. On July 20, 1989, a release of fuel oils was reported to the Illinois Environmental Protection Agency (IEPA). In January 2008, this facility received a No Further Remediation (NFR) letter for the LUST incident. H&H further reviewed the site using the IEPA Document Explorer Website and identified the former location of the UST at the southwest portion of the property. This site was identified as a Moderate Risk REC and **is considered a PIP**.



Weiland Partnership

The property was identified as a Resource Conservation and Recovery Act (RCRA) generator of hazardous waste, FINDS, UST, and LUST facility. According to the database report, three (3) heating oil USTs and one (1) gasoline UST were reportedly last used in 1968 and 1973 and were removed on August 26, 1993. Two (2) LUST incidents are associated with the facility. On April 4, 1990, a release of diesel fuel was reported to the IEPA, and on July 13, 1995, a release of fuel oil was reported to the IEPA. An NFR letter has been received for the diesel fuel release, but an NFR letter is not associated with the fuel oil release. This site was identified as a High Risk REC and **is considered a PIP**.

Single-Family Residences

These properties consist of three (3) one-story single-family residences with detached garages located between the CN Railway and Pet Lane, along Aptakistic Road. Based on historical information, these residences were developed in the 1940s. During the property reconnaissance, various trash and debris was observed on the properties. The debris consisted of 55-gallon drums, various sized containers, vehicle parts, non-operational vehicles, and various debris including plastic, wood, and metals. The owner of the northern adjoining property (Rolling Hills Nursery) stated that these properties use private septic systems for sanitary sewage. This site was identified as a Moderate Risk REC and **is considered a PIP**.

Residential Property

The property was observed as a single-family residence with a detached garage and appeared to be a junk yard/auto repair facility. During property reconnaissance, the property appeared to be utilized as an auto repair facility. The property's signage identified the occupant as "Caribbean Landscape, Inc."; however, automobile parts, machinery, and other miscellaneous equipment were observed on the property. In addition, what appeared to be an employee changing the oil of a vehicle, with the oil spilling directly onto bare soil, was witnessed. Numerous other soil stains were observed on the property. In addition, this site utilizes a private septic system for sanitary sewage. This site was identified as a High Risk REC and **is considered a PIP**.

American Pet Hotel

The property consists of approximately nine (9) buildings currently utilized as a dog kennel. The facility manager indicated the site uses a private septic system for sanitary sewage, and the septic leach field is located on the northern portion of the property (location of the to-be-constructed roadway). The facility manager also indicated the property was formerly utilized as agricultural land and the existing buildings were constructed in the mid-1970s. This site was identified as a Moderate Risk REC and **is considered a PIP**.

Rolling Hills Nursery

The property was developed with a commercial building and attached garage. The remaining portion of the property was occupied by a nursery consisting of various flowers, plants, mulch, and trees. The property was identified as a RCRA Small Quantity Generator (SQG) of hazardous waste and FINDS facility. During the property reconnaissance, pooled rain water was observed with a minor oily sheen. Various trash and debris was also observed along the western portion of the property. Based on the historic nature of this property, there is potential for pesticide, herbicide, and fertilizer usage. According to the property owner, a septic system is utilized for sanitary drainage. This site was identified as a High Risk REC and **is considered a PIP**.



Wooded Land

The property was observed as wooded land located on the southeast corner of IL Route 22 and North Prairie Road. During property reconnaissance, various water bodies were observed within the wooded area. A sheen covering a small area, approximately two (2) feet long, was observed on the edge of one of the water bodies. However, evidence of potential dumping, storage of hazardous materials, and/or dumping was not observed in the vicinity. As such, the origin of the sheen is unknown. One (1) abandoned, empty heating oil aboveground storage tank (AST), approximately 800-gallons in capacity, was observed on the central portion of the wooded area. Areas of staining were not apparent; however, a faint odor of petroleum-based oil was noted. This site was identified as a Moderate Risk REC and **is considered a PIP**.

CN Railway

The property was observed during property reconnaissance activities in August 2017 by H&H. Railroads are historically known for transporting a wide variety of chemicals. Additionally, weed control such as herbicides and pesticides, are known to have been commonly used along railroad track. Based on this information, this site **is considered a PIP**.

Subsurface Investigation

The PIPs were further evaluated by a Preliminary Subsurface Investigation (PSI), dated September 2017, to characterize potential impacts associated with the PIPs, as well as to determine suitability for CCDD disposal of any excavated material within the Project Corridor. On August 7, August 8, and August 22, Environmental Soil Probing (ESP), under the supervision of H&H, advanced 33 soil borings along the Project Corridor to depths between 8 and 16 feet below ground surface (bgs), as appropriate, to reflect the maximum anticipated depth of excavation for the planned improvements. The PSI report is included in **Attachment C (on CD)** for reference. Note, only 27 soil borings were performed within the project limits of this 663-Form and are discussed herein.

The 27 soil boring locations were determined based on potential impacts associated with the eight (8) PIPs, and to best represent the Project Corridor from a soil management perspective. Specifically, soil borings SB-1 to SB-18 were performed to assess conditions adjacent to PIPs, and soil borings SB-25 to SB-34 were performed for soil management and characterization purposes. Note that SB-10 was not performed due to risk of damaging underground utilities. Also note that soils within the CN Railway could not be assessed as part of the PSI. A figure in **Attachment A** depicts the location of the soil borings relative to the identified PIPs. A photo log of the subsurface investigation is included in **Attachment B**.

Soil sample(s) were selected from each soil boring for laboratory analysis of one or more constituents identified as contaminants of concern (COCs) and/or analyzed in field for soil pH. Samples were submitted for laboratory analysis based on PID screening results, geological considerations, and other visual/olfactory observations. The analysis conducted includes one or more of the following: volatile organic compounds (VOCs); benzene, toluene, ethyl benzene, and total xylenes (BTEX, a sub-set of the VOC list); polynuclear aromatic compounds (PNAs), 8 total RCRA metals¹, pesticides, and herbicides. Samples were also analyzed in field for soil pH using a digital Hanna direct soil pH meter (HI99121) to assess CCDD suitability of 663 Corridor soils.

¹ Total RCRA metals includes arsenic, barium, cadmium, chromium, lead, mercury, silver, and selenium.



Soil sample PID readings were at or near background as confirmed by laboratory analysis of samples. Tables summarizing the PID readings, analyses, and analytical results are included in **Attachment D**. The laboratory analytical report is also included in **Attachment D** for reference.

Analytical Results Summary

Analytical results were compared to the Maximum Allowable Concentrations (MACs) for assessment of disposal options, and the results are summarized by COC below.

VOCs

Table 3-2, included in **Attachment D**, presents the soil VOC (and subset BTEX) results compared to the MACs. Fourteen (14) samples were analyzed for VOCs, and three (3) additional samples were analyzed for BTEX to address potential petroleum impacts. Samples SB-1 (5-8 feet) and SB-4 (3-5 feet) had reportable detections of toluene (0.005 mg/kg) and chloroform (0.027 mg/kg), respectively. However, the results achieved their respective MACs. The remaining VOC (and subset BTEX) results were below reporting limits for the samples analyzed, achieving the MACs.

PNAs

Table 3-4, included in **Attachment D**, presents the soil PNA results compared to the MACs. Fifteen (15) soil samples were analyzed for PNAs. The following three samples had reportable detections of one or more PNAs: SB-1 (5-8 feet); SB-13 (3-5 feet); and SB-17 (1-3 feet). Several PNA constituents were detected at low concentrations in each of these samples. However, PNA detections achieved their respective MACs. The remaining PNA results were below reporting limits for the samples analyzed, achieving the MACs.

Total Metals

Table 3-6, included in **Attachment D**, presents the soil metals results compared to the MACs. Four (4) soil samples were analyzed for the 8 total RCRA metals. Each sample had reportable detections of arsenic, barium, chromium, lead, and silver. However, RCRA metals detections achieved their respective MACs. The remaining RCRA metals results were below reporting limits for the samples analyzed, achieving the MACs.

Pesticides/Herbicides

Table 3-8, included in **Attachment D**, presents the soil pesticides and herbicides results compared to the MACs. Nine (9) soil samples were analyzed for pesticides, and six (6) soil samples were analyzed for herbicides. The sample results for pesticides and herbicides were below reporting limits for the samples analyzed, achieving the MACs.

Soil pH

The pH sampling report is included in **Attachment D** for reference. Twenty-seven (27) soil samples were analyzed for soil pH by H&H using a digital Hanna direct soil pH meter (HI99121) and are considered representative of the 663 Corridor. CCDD regulations require soil pH between 6.25 and 9.00 to be acceptable for disposal at a CCDD facility or Uncontaminated Soil Fill Operation (USFO). The soil pH results ranged from 7.03 to 8.50, within the required 6.25 to 9.00 range for CCDD disposal.



CCDD Determination

Based on the due diligence and analytical testing conducted, soils generated from Stages I, III, and IV of the Weiland Road Improvement Project (663 Corridor) meet the requirements for CCDD or USFO facilities located within the following areas:

- Within City of Chicago Corporate Limits;
- Within a populated area² in a Metropolitan Statistical Area (MSA)³;
- Within a populated area in a non-MSA county; and
- Outside a populated area.

However, soils within the CN Railway ROW are precluded from acceptance at CCDD facilities or USFOs, as they were not assessed during the PSI. Soils generated from this area are NOT certified for CCDD disposal, and if design cannot avoid these soils or reuse them within the Project Corridor, they require disposal at a subtitle D sanitary landfill or analytical testing for CCDD characterization. A CCDD exclusion map is included in **Attachment A**.

Should conditions within the 663 Corridor differ from those encountered in the Preliminary Site Investigation, such as observed unusual staining, odors, elevated PID readings, or if loads become rejected, additional analytical assessment may be required for final disposition of spoils from this Project. If you have any questions regarding this matter, please contact us at 630-684-9100.

J:\81.0220092.27 CivTch Weiland Road\Reports\LPC-663\663 Narrative CivTch Weiland.docx

² “Populated Area” means: an area within the boundaries of a municipality that has a population of 10,000 or greater based on the year 2000 or most recent census; or an area less than three miles from the boundary of a municipality that has a population of 10,000 or greater based on the year 2000 or most recent census.

³ Counties within Metropolitan Statistical Areas: Boone, Champaign, Clinton, Cook, DuPage, Grundy, Henry, Jersey, Kane, Kankakee, Kendall, Lake, Macon, Madison, McHenry, McLean, Menard, Monroe, Peoria, Rock Island, Sangamon, St. Clair, Tazewell, Will, Winnebago, and Woodford.



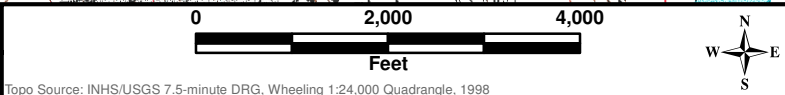
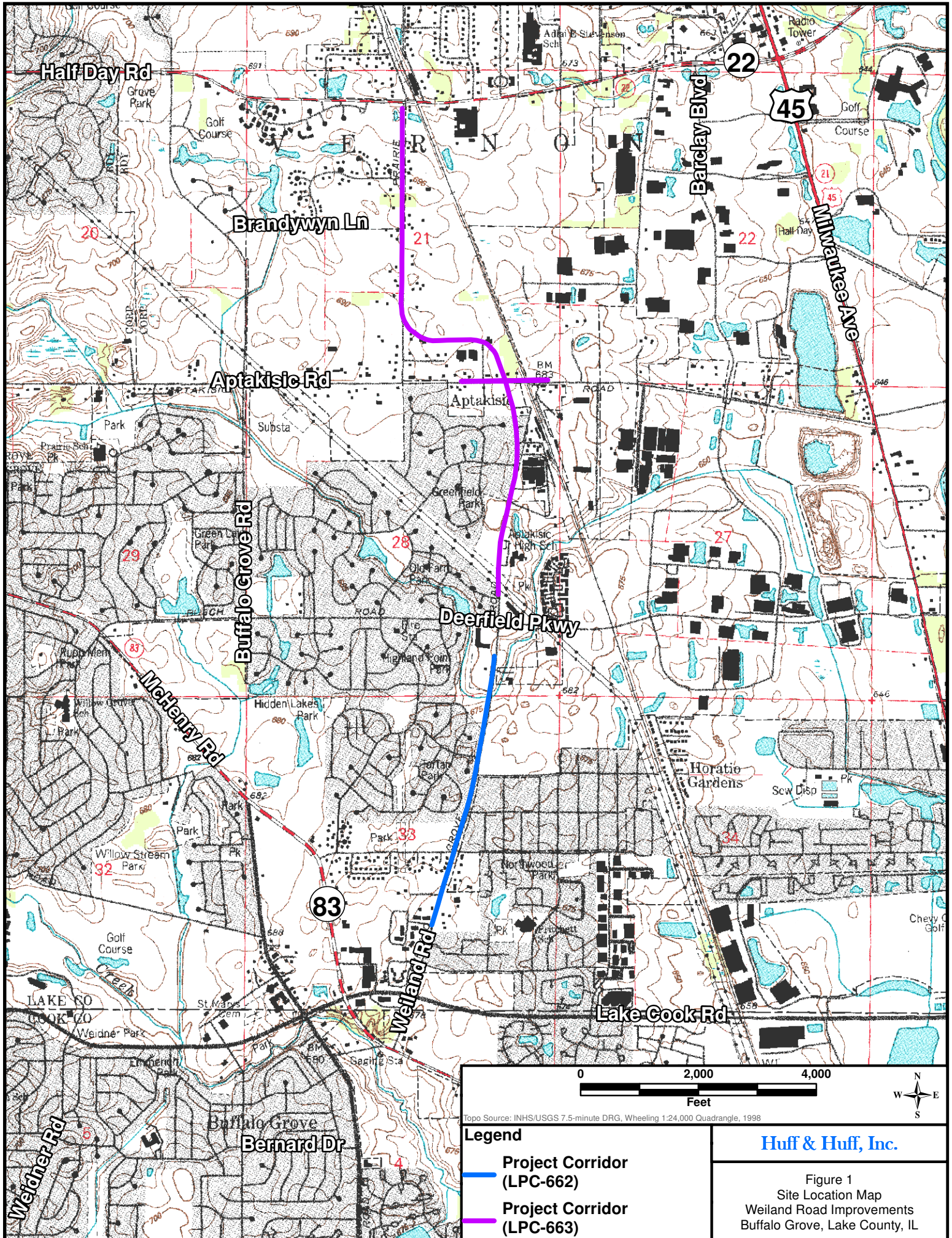

ATTACHMENT A

FIGURES



Topo Source: INHS/USGS 7.5-minute DRG, Wheeling 1:24,000 Quadrangle, 1998

Legend	
	Project Corridor (LPC-662)
	Project Corridor (LPC-663)

Huff & Huff, Inc.

Figure 1
 Site Location Map
 Weiland Road Improvements
 Buffalo Grove, Lake County, IL



Aerial Source: ESRI Online World Imagery

Legend

- Project Corridor (LPC-662)
- pH Only Borings

Huff & Huff, Inc.

Figure 2
Soil Boring Location Map – LPC-662
Weiland Road Improvements
Buffalo Grove, Lake County, IL

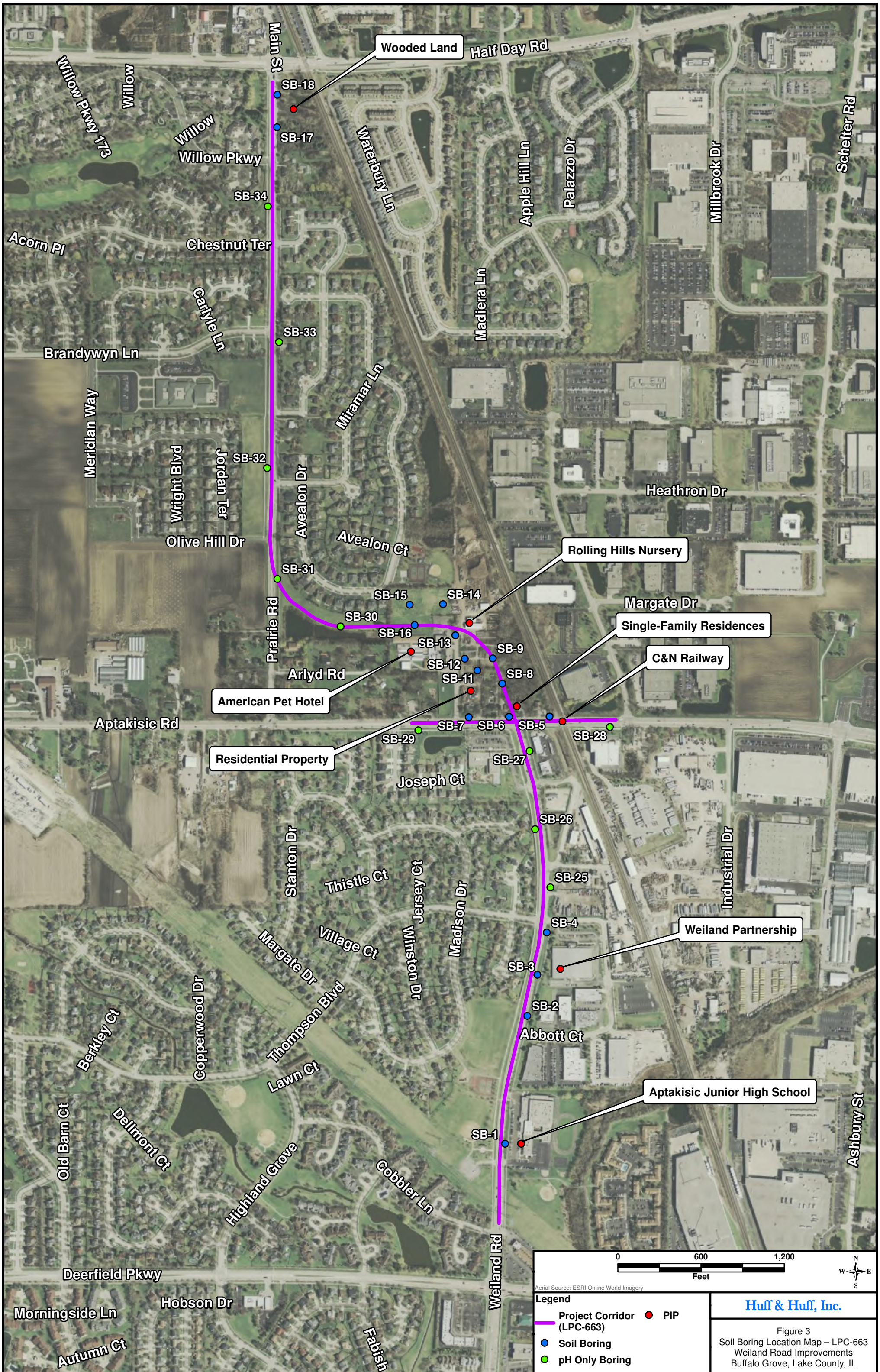

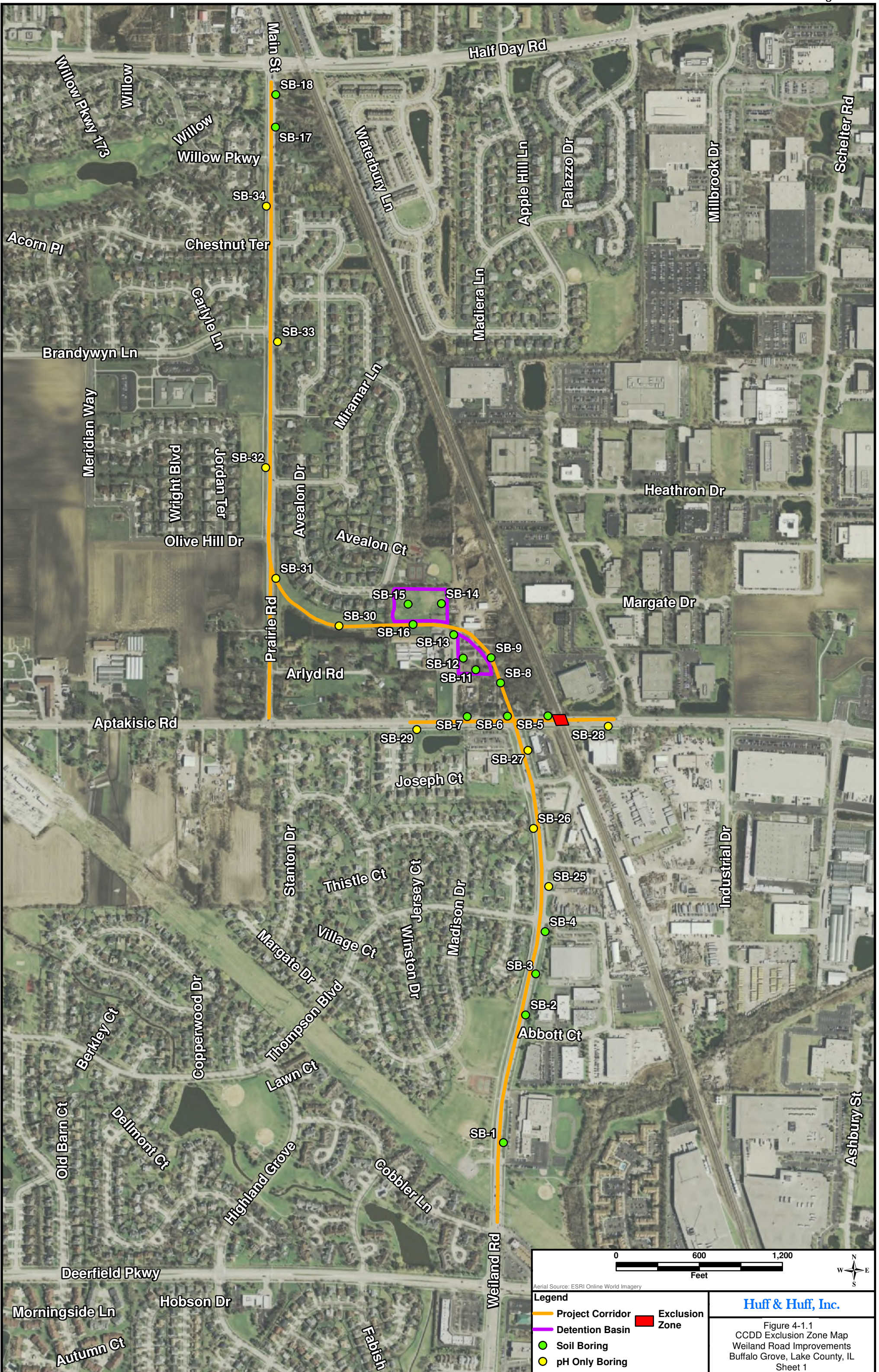



BLUFF CITY MATERIALS, INC

**2252 SOUTHWIND BLVD
BARTLETT, IL 60103**

7 February 2019

Jeremy J. Reynolds, P.G.
Senior Geologist
Huff & Huff, Inc.
A subsidiary of GZA GeoEnvironmental, Inc.
915 Harger Road, Suite 330
Oak Brook, IL 60523
Office: 630-684-9100
Fax: 630-684-9120
Cell: 224-423-3489

Re: Letter of Acceptance
Weiland Road Improvements CCDD
Weiland Road Buffalo Grove

Dear Mr. Reynolds:

Bluff City Materials has reviewed the Huff & Huff LPC-662, LPC-663, and supporting documents for the project located on Weiland Road in Buffalo Grove, IL. Based on the project information provided in your LPC-662/LPC-663 certifications, Bluff City Materials agrees to accept the CCDD specified/labeled material at our facilities located in Elgin and Lake in the Hills, IL. The following areas are excluded-

- Material within the red area depicted in the page 2 map.

Bluff City Materials is permitted by the IEPA to accept this material and our IEPA Permit number is CCDD2007-028-DE/OP. All loads entering the facility are inspected visually, with a photo ionization detector (PID) meter, and manifested from the source location. Our facilities comply with all local zoning codes and all applicable local, state and federal rules and regulations.

If you have any questions, please contact me at 630.497.8700 x 289

Sincerely,

Andy Paxson
Bluff City Materials
Environmental Assessments

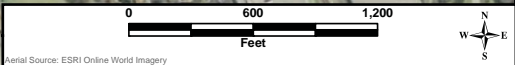
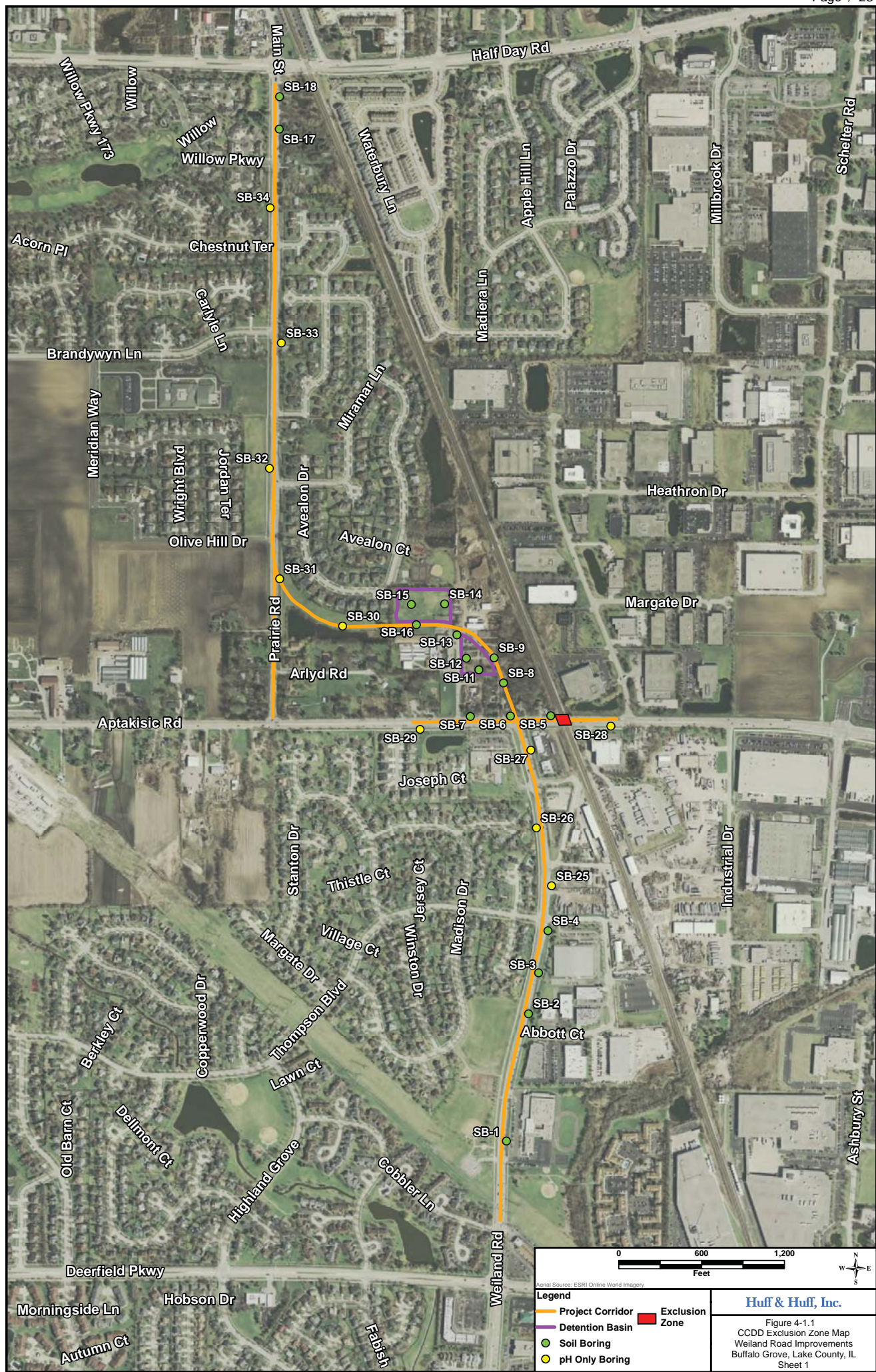

Aerial Source: ESRI Online World Imagery

Legend	
—	Project Corridor
—	Detention Basin
●	Soil Boring
●	pH Only Boring
■	Exclusion Zone

Huff & Huff, Inc.

Figure 4-1.1
 CCDD Exclusion Zone Map
 Welland Road Improvements
 Buffalo Grove, Lake County, IL
 Sheet 1

BITUMINOUS MATERIALS COST ADJUSTMENTS (BDE)

Effective: November 2, 2006

Revised: August 1, 2017

Description. Bituminous material cost adjustments will be made to provide additional compensation to the Contractor, or credit to the Department, for fluctuations in the cost of bituminous materials when optioned by the Contractor. The bidder shall indicate with their bid whether or not this special provision will be part of the contract.

The adjustments shall apply to permanent and temporary hot-mix asphalt (HMA) mixtures, bituminous surface treatments (cover and seal coats), and preventative maintenance type surface treatments that are part of the original proposed construction, or added as extra work and paid for by agreed unit prices. The adjustments shall not apply to bituminous prime coats, tack coats, crack filling/sealing, joint filling/sealing, or extra work paid for at a lump sum price or by force account.

Method of Adjustment. Bituminous materials cost adjustments will be computed as follows.

$$CA = (BPI_P - BPI_L) \times (\%AC_V / 100) \times Q$$

Where: CA = Cost Adjustment, \$.

BPI_P = Bituminous Price Index, as published by the Department for the month the work is performed, \$/ton (\$/metric ton).

BPI_L = Bituminous Price Index, as published by the Department for the month prior to the letting for work paid for at the contract price; or for the month the agreed unit price letter is submitted by the Contractor for extra work paid for by agreed unit price, \$/ton (\$/metric ton).

%AC_V = Percent of virgin Asphalt Cement in the Quantity being adjusted. For HMA mixtures, the % AC_V will be determined from the adjusted job mix formula. For bituminous materials applied, a performance graded or cutback asphalt will be considered to be 100% AC_V and undiluted emulsified asphalt will be considered to be 65% AC_V.

Q = Authorized construction Quantity, tons (metric tons) (see below).

For HMA mixtures measured in square yards: $Q, \text{ tons} = A \times D \times (G_{mb} \times 46.8) / 2000$. For HMA mixtures measured in square meters: $Q, \text{ metric tons} = A \times D \times (G_{mb} \times 1) / 1000$. When computing adjustments for full-depth HMA pavement, separate calculations will be made for the binder and surface courses to account for their different G_{mb} and % AC_V.

For bituminous materials measured in gallons: $Q, \text{ tons} = V \times 8.33 \text{ lb/gal} \times SG / 2000$

For bituminous materials measured in liters: $Q, \text{ metric tons} = V \times 1.0 \text{ kg/L} \times SG / 1000$

Where: A = Area of the HMA mixture, sq yd (sq m).

D = Depth of the HMA mixture, in. (mm).

G_{mb} = Average bulk specific gravity of the mixture, from the approved mix design.

V = Volume of the bituminous material, gal (L).
SG = Specific Gravity of bituminous material as shown on the bill of lading.

Basis of Payment. Bituminous materials cost adjustments may be positive or negative but will only be made when there is a difference between the BPI_L and BPI_P in excess of five percent, as calculated by:

$$\text{Percent Difference} = \{(BPI_L - BPI_P) \div BPI_L\} \times 100$$

Bituminous materials cost adjustments will be calculated for each calendar month in which applicable bituminous material is placed; and will be paid or deducted when all other contract requirements for the work placed during the month are satisfied. The adjustments shall not apply during contract time subject to liquidated damages for completion of the entire contract.

80173

**BUILDING REMOVAL - CASE I (NON-FRIABLE AND FRIABLE ASBESTOS ABATEMENT)
(BDE)**

Effective: September 1, 1990

Revised: April 1, 2010

BUILDING REMOVAL: This work shall consist of the removal and disposal of two (2) building(s), together with all foundations, retaining walls, and piers, down to a plane 1 ft (300 mm) below the ultimate or existing grade in the area and also all incidental and collateral work necessary to complete the removal of the building(s) in a manner approved by the Engineer. Any holes, such as basements, shall be filled with a suitable granular material. The building(s) are identified as follows:

<u>Bldg. No.</u>	<u>Parcel No.</u>	<u>Location</u>	<u>Description</u>
1	0045	16154 Aptakisic, Prairie View IL 60069	Single Family Wood Frame 2-story
2	0045	16154 Aptakisic, Prairie View IL 60069	Detached 2-car garage Wood Frame

Discontinuance of Utilities: The Contractor shall arrange for the discontinuance of all utility services and the removal of the metering devices that serve the building(s) according to the respective requirements and regulations of the City, County, or utility companies involved. The Contractor shall disconnect and seal, in an approved manner, all service outlets that serve any building(s) he/she is to remove.

Signs: Immediately upon execution of the contract and prior to the wrecking of any structures, the Contractor shall be required to paint or stencil, in contrasting colors of an oil base paint, on all four sides of each residence and two opposite sides of other structures, the following sign:

PROPERTY ACQUIRED FOR
HIGHWAY CONSTRUCTION
TO BE DEMOLISHED BY THE

VANDALS WILL BE PROSECUTED

The signs shall be positioned in a prominent location on the structure so that they can be easily seen and read and at a sufficient height to prevent defacing. The Contractor shall not paint signs nor start demolition of any building(s) prior to the time that the State becomes the owner of the respective building(s).

All friable asbestos shall be removed from the building(s) prior to demolition. The Contractor has the option of removing the non-friable asbestos prior to demolition or demolishing the building(s) with the non-friable asbestos in place. Refer to the Special Provisions titled "Asbestos Abatement (General Conditions)", "Removal and Disposal of Friable Asbestos Building No. 1", and "Removal and Disposal of Non-Friable Asbestos Building No. 1 & 2" contained herein.

Basis of Payment: This work will be paid for at the contract lump sum unit price for BUILDING REMOVAL, numbers as listed above, which price shall be payment in full for complete removal of the buildings and structures, including any necessary backfilling material as specified herein. The lump sum unit price(s) for this work shall represent the cost of demolition and disposal assuming all asbestos, friable and non-friable, is removed prior to demolition. Any salvage value shall be reflected in the contract unit price for this item.

EXPLANATION OF BIDDING TERMS: Three separate contract unit price items have been established for the removal of each building. They are:

1. BUILDING REMOVAL NO. 1 and 2
2. REMOVAL AND DISPOSAL OF FRIABLE ASBESTOS, BUILDING NO. 1
3. REMOVAL AND DISPOSAL OF NON-FRIABLE ASBESTOS, BUILDING NO. 1 and 2

The Contractor shall have two options available for the removal and disposal of the non-friable asbestos.

The pay item for removal and disposal of non-friable asbestos will not be deleted regardless of the option chosen by the Contractor.

ASBESTOS ABATEMENT (GENERAL CONDITIONS): This work consists of the removal and disposal of friable and non-friable asbestos from the building(s) to be demolished. All work shall be done according to the requirements of the U.S. Environmental Protection Agency (USEPA), the Illinois Environmental Protection Agency (IEPA), the Occupational Safety and Health Administration (OSHA), the Special Provisions for "Removal and Disposal of Friable Asbestos, Building No. 1" and "Removal and Disposal of Non-Friable Asbestos, Building No. 1 & 2", and as outlined herein.

Sketches indicating the location of Asbestos Containing Material (ACM) are included in the proposal on pages 8 thru 15. Also refer to the Materials Description Table on page 16 & 17 for a brief description and location of the various materials. Also included is a Materials Quantities Table on page 16 & 17. This table states whether the ACM is friable or non-friable and gives the approximate quantity. The quantities are given only for information and it shall be the Contractor's responsibility to determine the exact quantities prior to submitting his/her bid.

The work involved in the removal and disposal of friable asbestos, and non-friable asbestos if done prior to demolition, shall be performed by a Contractor or Sub-Contractor prequalified with the Illinois Capital Development Board.

The Contractor shall provide a shipping manifest, similar to the one shown on page 18, to the Engineer for the disposal of all ACM wastes.

Permits: The Contractor shall apply for permit(s) in compliance with applicable regulations of the Illinois Environmental Protection Agency. Any and all other permits required by other federal, state, or local agencies for carrying on the work shall be the responsibility of the Contractor. Copies of these permits shall be sent to the district office and the Engineer.

Notifications: The "Demolition/Renovation Notice" form, which can be obtained from the IEPA office, shall be completed and submitted to the address listed below at least ten days prior to commencement of any asbestos removal or demolition activity. Separate notices shall be sent for the asbestos removal work and the building demolition if they are done as separate operations.

Asbestos Demolition/Renovation Coordinator
Illinois Environmental Protection Agency
Division of Air Pollution Control
P. O. Box 19276
Springfield, Illinois 62794-9276
(217)785-1743

Notices shall be updated if there is a change in the starting date or the amount of asbestos changes by more than 20 percent.

Submittals:

- A. All submittals and notices shall be made to the Engineer, except where otherwise specified herein.
- B. Submittals that shall be made prior to start of work:
 1. Submittals required under Asbestos Abatement Experience.
 2. Submit documentation indicating that all employees have had medical examinations and instruction on the hazards of asbestos exposure, on use and fitting of respirators, on protective dress, on use of showers, on entry and exit from work areas, and on all aspects of work procedures and protective measures as specified in Worker Protection Procedures.
 3. Submit manufacturer's certification stating that vacuums, ventilation equipment, and other equipment required to contain airborne fibers conform to ANSI 29.2.

4. Submit to the Engineer the brand name, manufacturer, and specification of all sealants or surfactants to be used. Testing under existing conditions will be required at the direction of the Engineer.
 5. Submit proof that all required permits, site locations, and arrangements for transport and disposal of asbestos-containing or asbestos-contaminated materials, supplies, and the like have been obtained (i.e., a letter of authorization to utilize designated landfill).
 6. Submit a list of penalties, including liquidated damages, incurred through non-compliance with asbestos abatement project specifications.
 7. Submit a detailed plan of the procedures proposed for use in complying with the requirements of this specification. Include in the plan the location and layout of decontamination units, the sequencing of work, the respiratory protection plan to be used during this work, a site safety plan, a disposal plan including the location of an approved disposal site, and a detailed description of the methods to be used to control pollution. The plan shall be submitted to the Engineer prior to the start of work.
 8. Submit proof of written notification and compliance with Paragraph "Notifications".
- C. Submittals that shall be made upon completion of abatement work:
1. Submit copies of all waste chain-of-custodies, trip tickets, and disposal receipts for all asbestos waste materials removed from the work area;
 2. Submit daily copies of work site entry logbooks with information on worker and visitor access;
 3. Submit logs documenting filter changes on respirators, HEPA vacuums, negative pressure ventilation units, and other engineering controls; and
 4. Submit results of any bulk material analysis and air sampling data collected during the course of the abatement including results of any on-site testing by any federal, state, or local agency.

Certificate of Insurance:

- A. The Contractor shall document general liability insurance for personal injury, occupational disease and sickness or death, and property damage.
- B. The Contractor shall document current Workmen's Compensation Insurance coverage.
- C. The Contractor shall supply insurance certificates as specified by the Department.

Asbestos Abatement Experience:

- A. Company Experience: Prior to starting work, the Contractor shall supply evidence that he/she has been prequalified with the Illinois Capital Development Board and that he/she has been included on the Illinois Department of Public Health's list of approved Contractors.
- B. Personnel Experience:
 - 1. For Superintendent, the Contractor shall supply:
 - a. Evidence of knowledge of applicable regulations in safety and environmental protection is required as well as training in asbestos abatement as evidenced by the successful completion of a training course in supervision of asbestos abatement as specified in 40 CFR 763, Subpart E, Appendix C, EPA Model Contractor Accreditation Plan. A copy of the certificate of successful completion shall be provided to the Engineer prior to the start of work.
 - b. Documentation of experience with abatement work in a supervisory position as evidenced through supervising at least two asbestos abatement projects; provide names, contact, phone number, and locations of two projects in which the individual(s) has worked in a supervisory capacity.
 - 2. For workers involved in the removal of friable and non-friable asbestos, the Contractor shall provide training as evidenced by the participation and successful completion of an accredited training course for asbestos abatement workers as specified in 40 CFR 763, Subpart E, Appendix C, EPA Model Contractor Accreditation Plan. A copy of the certificate of successful completion shall be provided to all employees who will be working on this project.

ABATEMENT AIR MONITORING: The Contractor shall comply with the following:

- A. Personal Monitoring: All personal monitoring shall be conducted per specifications listed in OSHA regulation, Title 29, Code of Federal Regulation 1926.58. All area sampling shall be conducted according to 40 CFR Part 763.90. All air monitoring equipment shall be calibrated and maintained in proper operating condition. Excursion limits shall be monitored daily. Personal monitoring is the responsibility of the Contractor. Additional personal samples may be required by the Engineer at any time during the project.
- B. Contained Work Areas for Removal of Friable Asbestos: Area samples shall be collected for the department within the work area daily. A minimum of one sample shall be taken outside of the abatement area removal operations. The Engineer will also have the option to require additional personal samples and/or clearance samples during this type of work.
- C. Interior Non-Friable Asbestos-Containing Materials: The Contractor shall perform personal air monitoring during removal of all nonfriable Transite and floor tile removal

operations. The Engineer will also have the option to require additional personal samples and/or clearance samples during this type of work.

- D. Exterior Non-Friable Asbestos-Containing Materials: The Contractor shall perform personal air monitoring during removal of all nonfriable cementitious panels, piping, roofing felts, and built up roofing materials that contain asbestos.

The Contractor shall conduct down wind area sampling to monitor airborne fiber levels at a frequency of no less than three per day.

E. Air Monitoring Professional

1. All air sampling shall be conducted by a qualified Air Sampling Professional supplied by the Contractor. The Air Sampling Professional shall submit documentation of successful completion of the National Institute for Occupational Safety and Health (NIOSH) course #582 - "Sampling and Evaluating Airborne Asbestos Dust".
2. Air sampling shall be conducted according to NIOSH Method 7400. The results of these tests shall be provided to the Engineer within 24 hours of the collection of air samples.

REMOVAL AND DISPOSAL OF FRIABLE ASBESTOS, BUILDING NO. 1: This work consists of the removal and disposal of all friable asbestos from the building(s) prior to demolition. The work shall be done according to the Special Provision titled "Asbestos Abatement (General Conditions)" and as outlined herein.

This work will be paid for at the contract unit price per lump sum for REMOVAL AND DISPOSAL OF FRIABLE ASBESTOS, BUILDING NO. 1, as shown, which price shall include furnishing all labor, materials, equipment and services required to remove and dispose of the friable asbestos.

REMOVAL AND DISPOSAL OF NON-FRIABLE ASBESTOS, BUILDING NO. 1 & 2: The Contractor has the option of removing and disposing of the non-friable asbestos prior to demolition of the building(s) or demolishing the building(s) with the non-friable asbestos in place.

Option #1 - If the Contractor chooses to remove all non-friable asbestos prior to demolition, the work shall be done according to the Special Provision titled "Asbestos Abatement (General Conditions)".

Option #2 - If the Contractor chooses to demolish the building(s) with the non-friable asbestos in place, the following provisions shall apply:

1. Continuously wet all non-friable ACM and other building debris with water during demolition.

2. Dispose of all demolition debris as asbestos containing material by placing it in lined, covered transport haulers and placing it in an approved landfill.

This work will be paid for at the contract unit price per lump sum for REMOVAL AND DISPOSAL OF NON-FRIABLE ASBESTOS, BUILDING NO. 1 & 2, as shown.

The cost for this work shall be determined as follows:

Option #1 - Actual cost of removal and disposal of non-friable asbestos.

Option #2 - The difference in cost between removing and disposing of the building if all non-friable asbestos is left in place and removing and disposing of the building assuming all non-friable asbestos is removed prior to demolition.

The cost of removing and disposing of the building(s), assuming all asbestos, friable and non-friable is removed first, shall be represented by the pay item "BUILDING REMOVAL NO. 1 & 2".

Regardless of the option chosen by the Contractor, this pay item will not be deleted, nor will the pay item BUILDING REMOVAL NO. 1 & 2 be deleted.

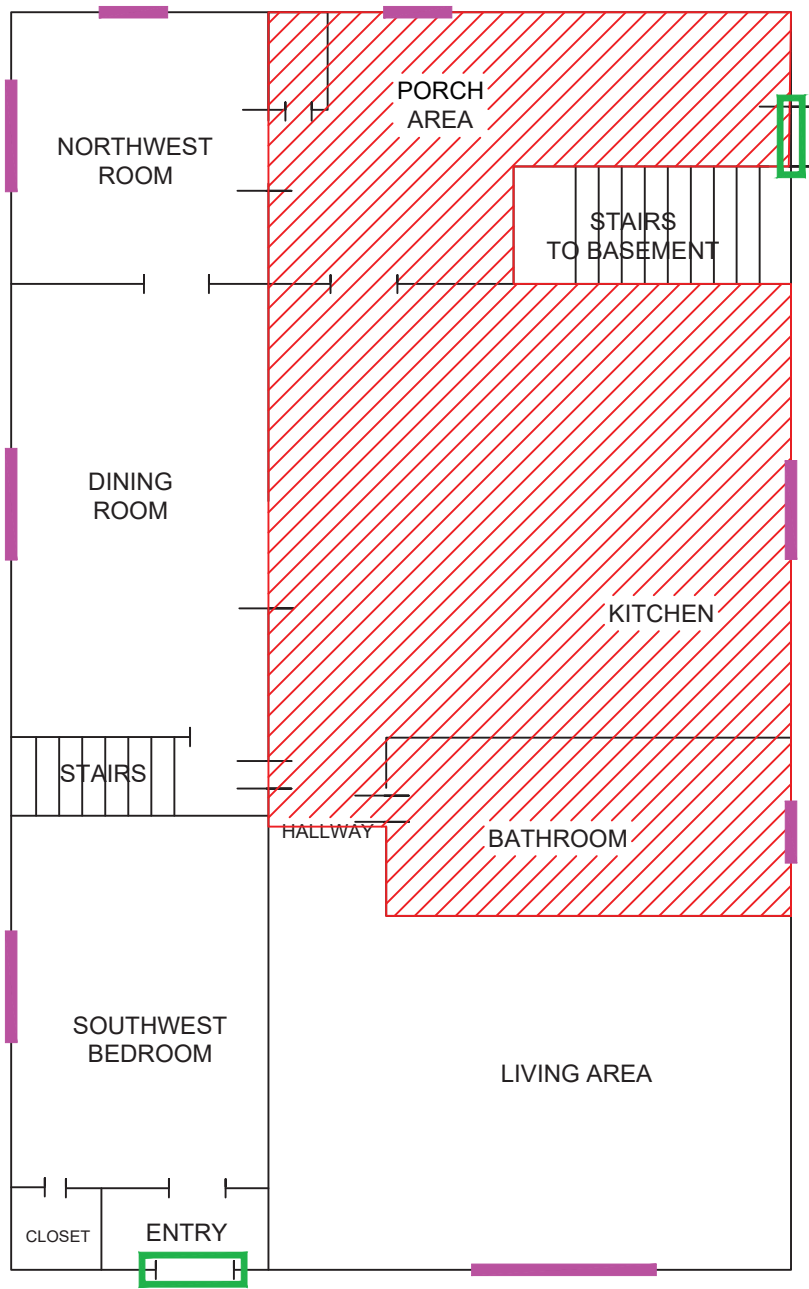

FIRST FLOOR

LEGEND:

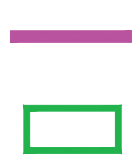

HA4 - EXTERIOR WINDOW GLAZE
 HA6 - EXTERIOR DOOR CAULK



HA7, HA8, HA13 - FIBER BACKING ON SHEET FLOORING

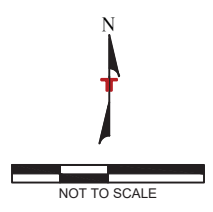

Project Mng:	HEE	Project No.	11147432
Drawn By:	SDM	Scale:	NOT-TO-SCALE
Checked By:	HEE	Revised By:	-
Approved By:	BJQ	Date:	December 5, 2018

Terracon
 Consulting Engineers and Scientists

192 EXCHANGE BOULEVARD GLENDALE HEIGHTS, ILLINOIS 60139
 PH. (630) 717-4263 FAX. (630) 357-9489

ASBESTOS LOCATION MAP

Parcel 0045
 16154 Aptakisic
 Prairie View, Illinois

EXHIBIT
1

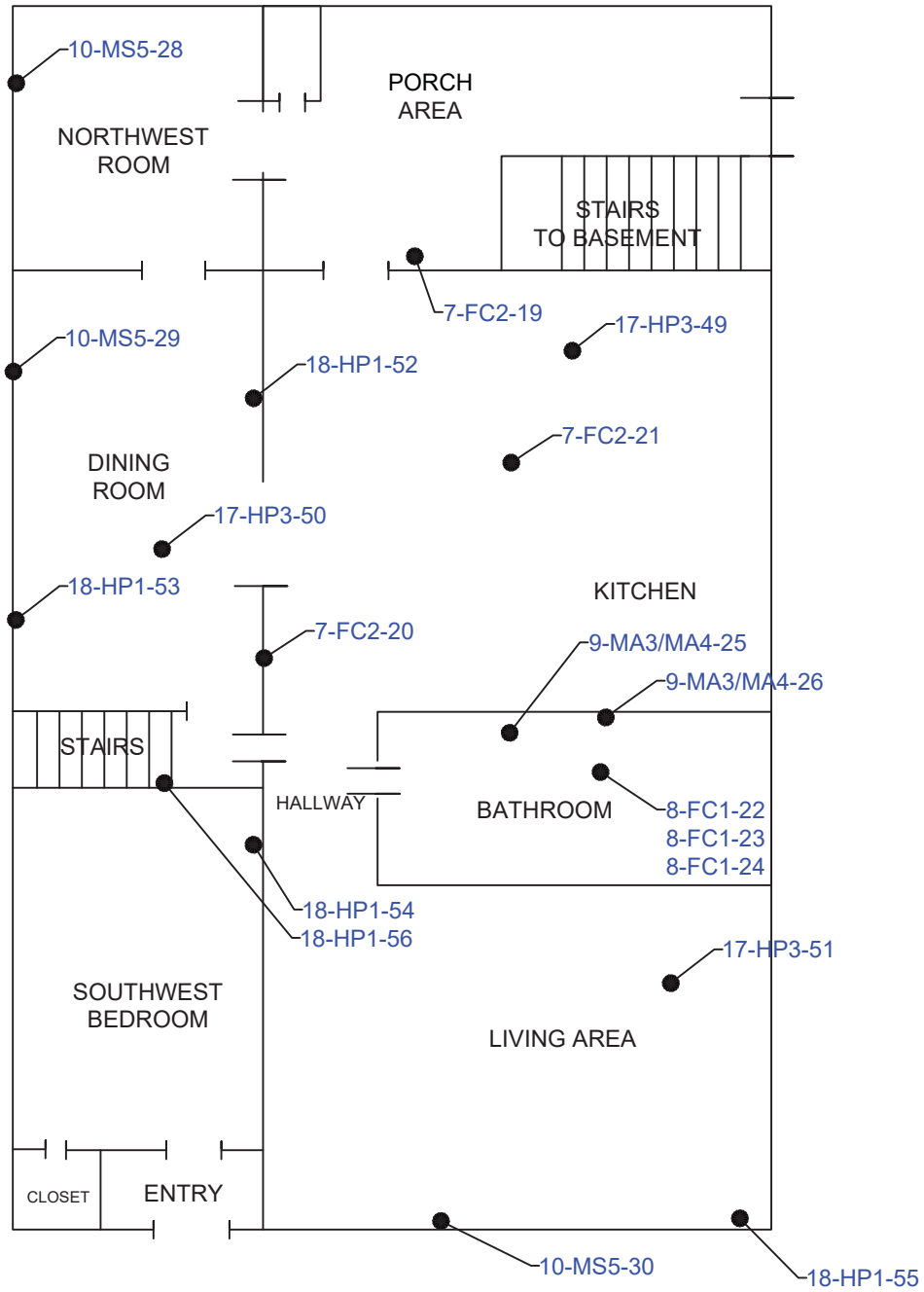

FIRST FLOOR

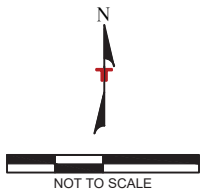

Project Mng:	HEE	Project No.	11147432
Drawn By:	SDM	Scale:	NOT-TO-SCALE
Checked By:	HEE	Revised By:	-
Approved By:	BJQ	Date:	December 5, 2018

Terracon
Consulting Engineers and Scientists

192 EXCHANGE BOULEVARD GLENDALE HEIGHTS, ILLINOIS 60139
PH. (630) 717-4263 FAX. (630) 357-9489



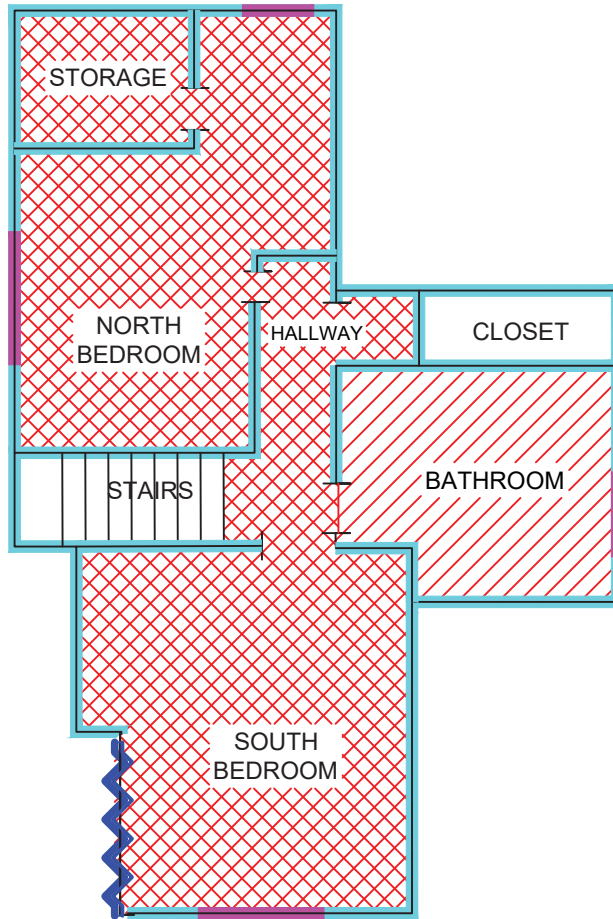

SAMPLE LOCATION MAP
Parcel 0045 16154 Aptakisic Prairie View, Illinois

EXHIBIT
1



SECOND FLOOR

LEGEND:

- | | | | |
|---|--|---|--|
|  | HA4 - EXTERIOR WINDOW GLAZE |  | HA7, HA8, HA13 - FIBER BACKING ON SHEET FLOORING |
|  | HA14 - DRYWALL JOINT COMPOUND |  | HA15 - 9" x 9" BROWN FLOOR AND BLACK MASTIC (UNDER CARPET AND 12" X 12" VINYL FLOOR TILES) |
|  | HA16 - WHITE PAPER (HEAT SHIELD) BEHIND RADIATOR | | |

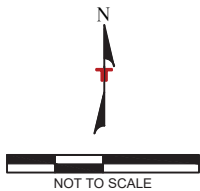

Project Mng:	HEE	Project No.	11147432
Drawn By:	SDM	Scale:	NOT-TO-SCALE
Checked By:	HEE	Revised By:	-
Approved By:	BJQ	Date:	December 5, 2018

Terracon
Consulting Engineers and Scientists

192 EXCHANGE BOULEVARD GLENDALE HEIGHTS, ILLINOIS 60139
PH. (630) 717-4263 FAX. (630) 357-9489

ASBESTOS LOCATION MAP
Parcel 0045 16154 Aptakisic Prairie View, Illinois

EXHIBIT
2

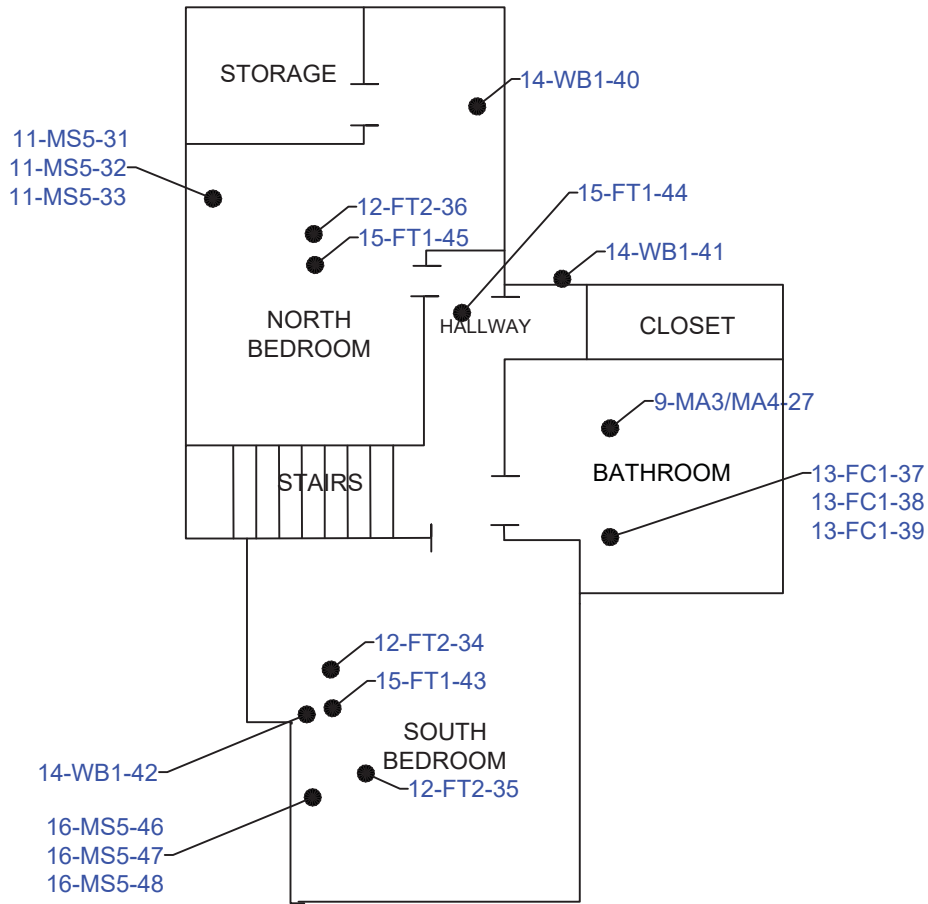

SECOND FLOOR

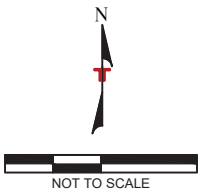

Project Mng:	HEE	Project No.	11147432
Drawn By:	SDM	Scale:	NOT-TO-SCALE
Checked By:	HEE	Revised By:	-
Approved By:	BJQ	Date:	December 5, 2018

Terracon
Consulting Engineers and Scientists

192 EXCHANGE BOULEVARD GLENDALE HEIGHTS, ILLINOIS 60139
PH. (630) 717-4263 FAX. (630) 357-9489

SAMPLE LOCATION MAP
Parcel 0045 16154 Aptakisic Prairie View, Illinois

EXHIBIT
2

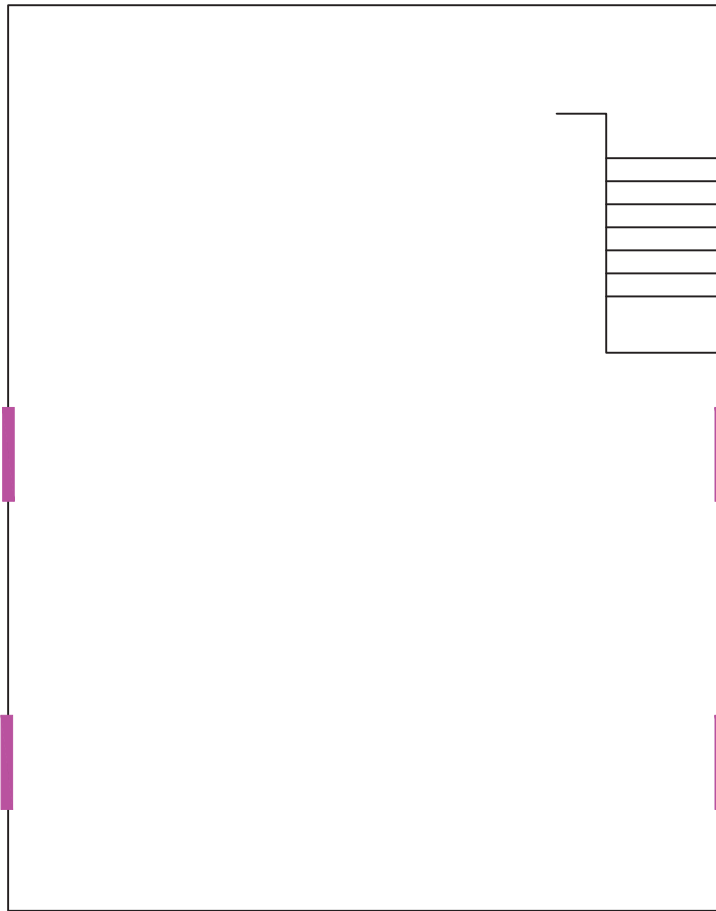

BASEMENT

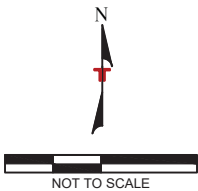

LEGEND:

HA4 - EXTERIOR WINDOW GLAZE

Project Mngr:	HEE	Project No.	11147432
Drawn By:	SDM	Scale:	NOT-TO-SCALE
Checked By:	HEE	Revised By:	-
Approved By:	BJQ	Date:	December 5, 2018



Terracon
Consulting Engineers and Scientists

192 EXCHANGE BOULEVARD GLENDALE HEIGHTS, ILLINOIS 60139
PH. (630) 717-4263 FAX. (630) 357-9489

ASBESTOS LOCATION MAP
Parcel 0045 16154 Aptakisic Prairie View, Illinois

EXHIBIT
3

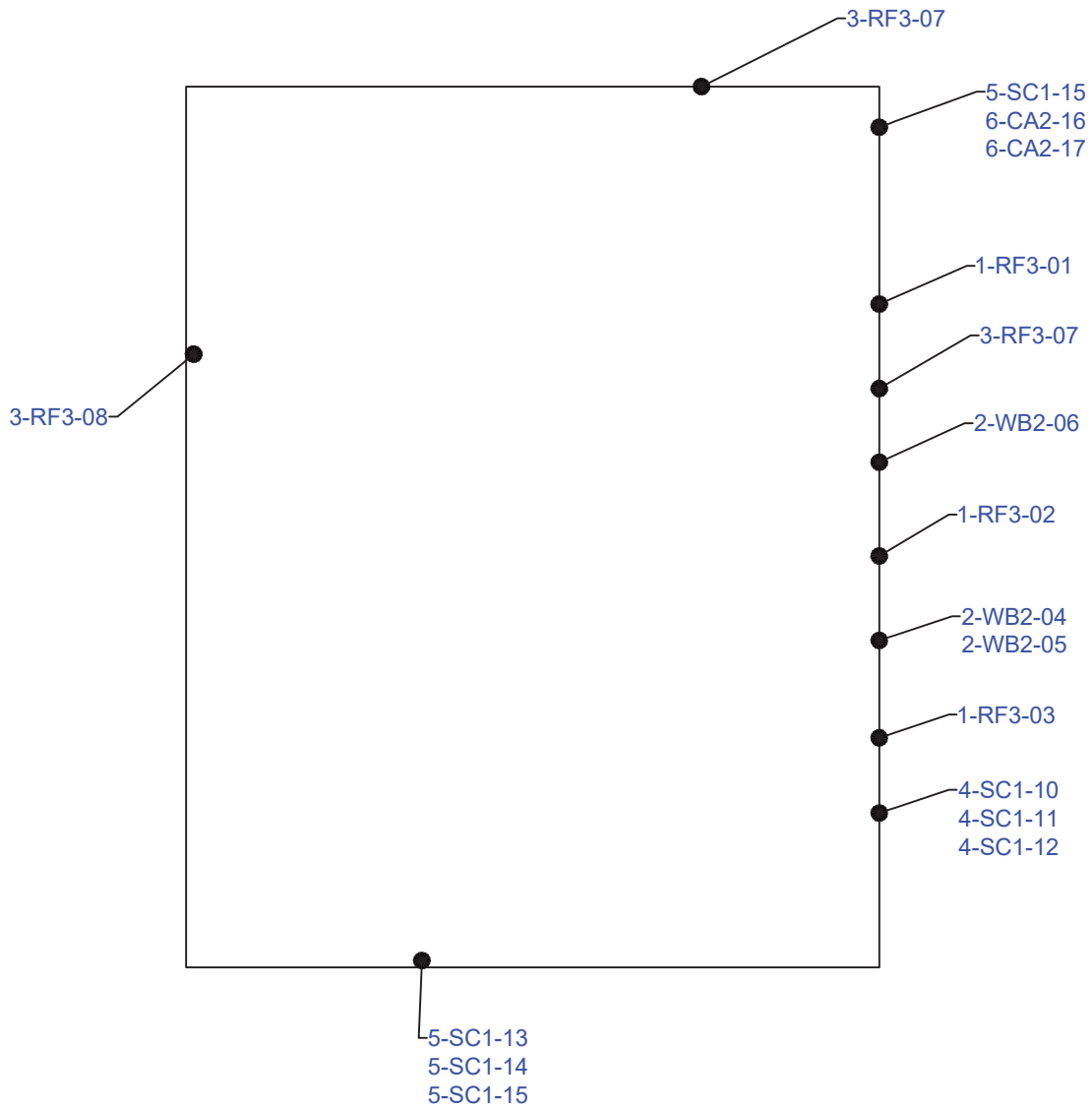

ROOF AND EXTERIOR

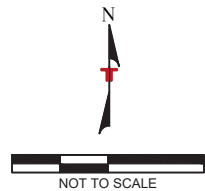

Project Mng:	HEE	Project No.	11147432
Drawn By:	SDM	Scale:	NOT-TO-SCALE
Checked By:	HEE	Revised By:	-
Approved By:	BJQ	Date:	December 5, 2018

Terracon
Consulting Engineers and Scientists

192 EXCHANGE BOULEVARD GLENDALE HEIGHTS, ILLINOIS 60139
PH. (630) 717-4263 FAX. (630) 357-9489

SAMPLE LOCATION MAP
Parcel 0045 16154 Aptakisic Prairie View, Illinois

EXHIBIT
3

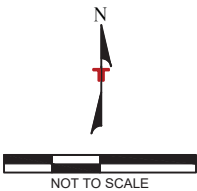
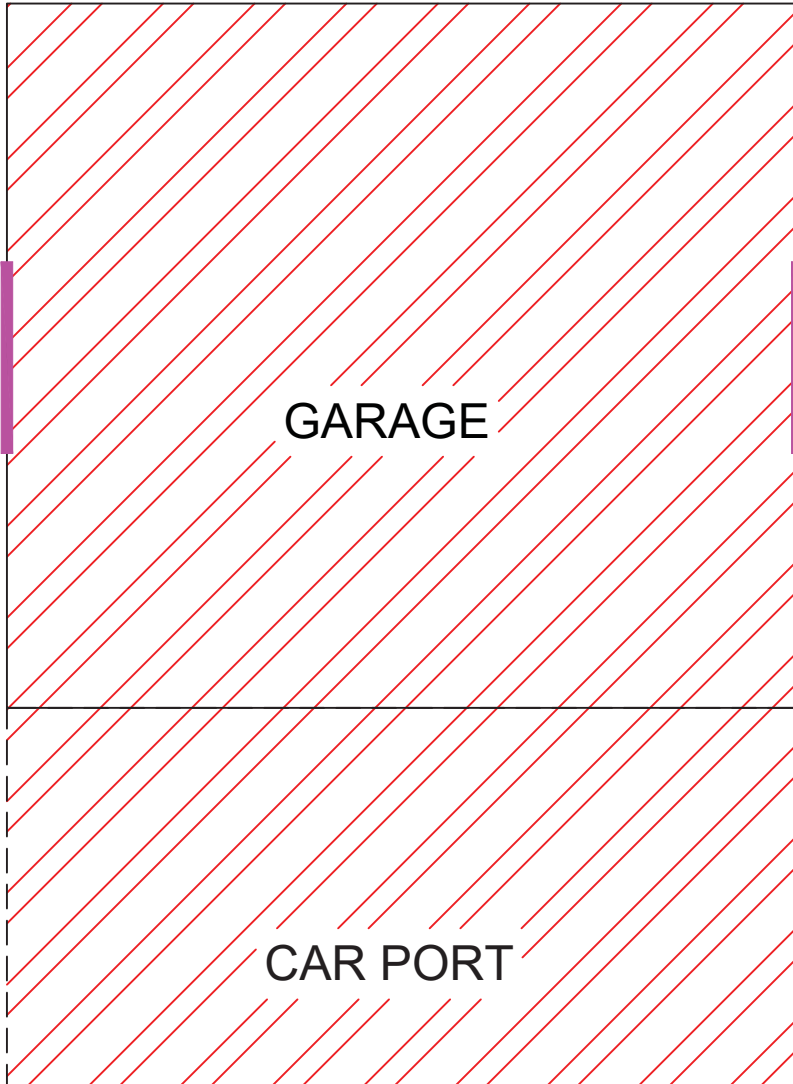

LEGEND:



HA19 - EXTERIOR WINDOW GLAZE



HA22, HA23 - FLASHING MATERIAL ON ROOF

Project Mng:	HEE	Project No.	11147432
Drawn By:	SDM	Scale:	NOT-TO-SCALE
Checked By:	HEE	Revised By:	-
Approved By:	BJQ	Date:	December 5, 2018

Terracon
Consulting Engineers and Scientists

192 EXCHANGE BOULEVARD GLENDALE HEIGHTS, ILLINOIS 60139
PH. (630) 717-4263 FAX. (630) 357-9489

ASBESTOS LOCATION MAP

Parcel 0045
16154 Aptakisic
Prairie View, Illinois

EXHIBIT
4

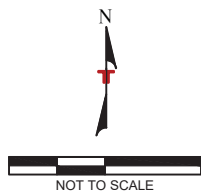
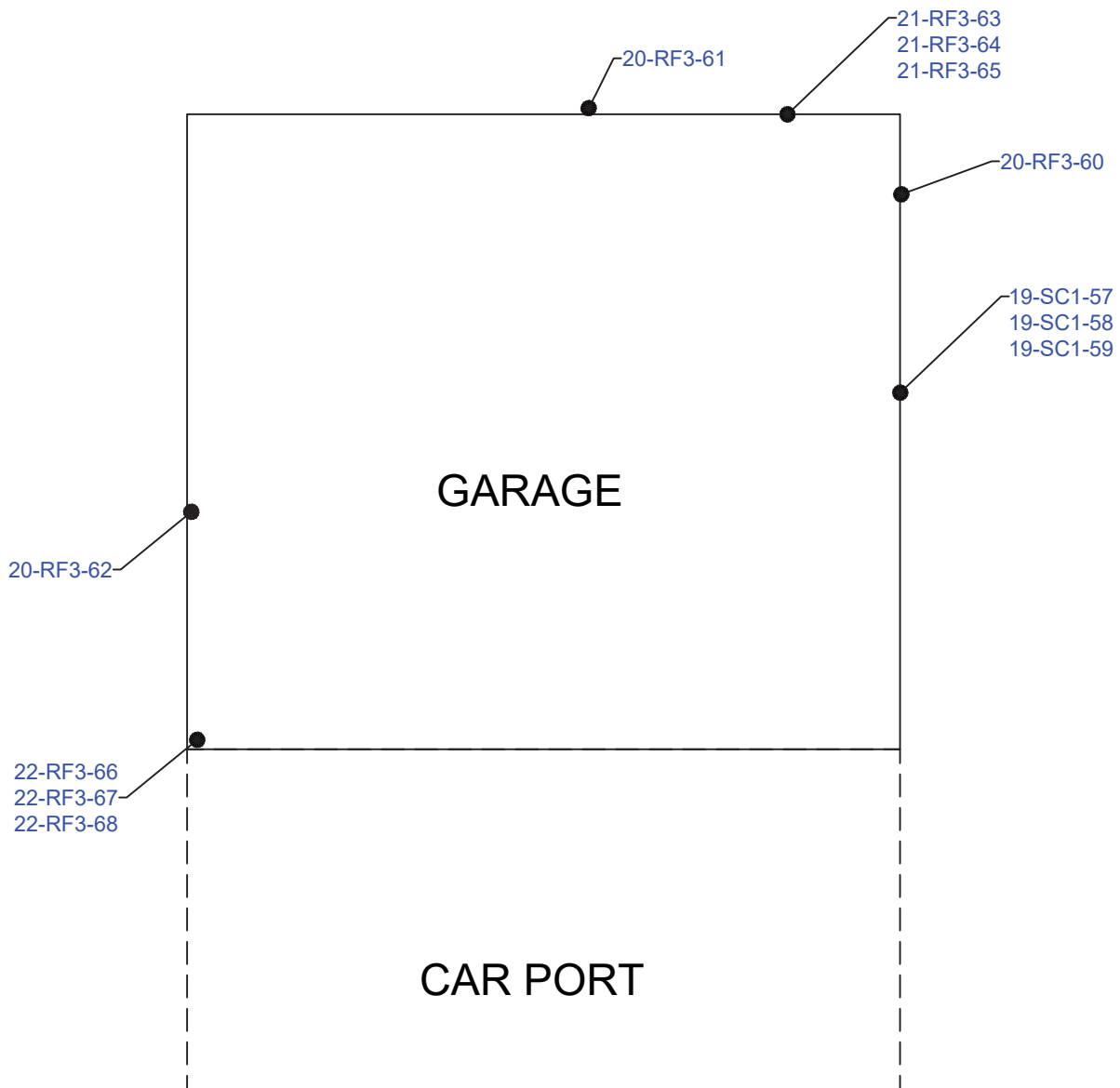

Project Mng:	HEE	Project No.	11147432
Drawn By:	SDM	Scale:	NOT-TO-SCALE
Checked By:	HEE	Revised By:	-
Approved By:	BJQ	Date:	December 5, 2018

Terracon
 Consulting Engineers and Scientists

192 EXCHANGE BOULEVARD GLENDALE HEIGHTS, ILLINOIS 60139
 PH. (630) 717-4263 FAX. (630) 357-9489

SAMPLE LOCATION MAP
Parcel 0045 16154 Aptakisic Prairie View, Illinois

EXHIBIT
4

APPENDIX B

**CONFIRMED ASBESTOS-CONTAINING MATERIALS
SINGLE FAMILY HOUSE AND DETACHED GARAGE
16154 APTAKASIC
PRAIRIE VIEW, ILLINOIS**

**Terracon Project No. 11147432
December 5, 2018**

HA No.	Description	Material Location	NESHAP Classification	Percent/Type Asbestos	Estimated Quantity*
Single-Family House					
4	Exterior window glazing	All windows	Category II non-friable	2% Chrysotile	300 LF
6	Exterior door caulk	Front door & side door	Category II non-friable	5% Chrysotile	30 LF
7	Fiber backing on beige rock pattern sheet flooring	East entrance vestibule & kitchen	RACM	45% Chrysotile	240 SF
8	Fiber backing on tan square pattern sheet flooring	1 st floor bathroom	RACM	45% Chrysotile	50 SF
13	Fiber backing on beige terrazzo pattern sheet flooring	2 nd floor bathroom	RACM	45% Chrysotile	100 SF
14	Drywall joint compound	2nd floor walls & ceilings	RACM	2% Chrysotile	2,100 SF
15	9"x9" brown floor tile and black mastic	2 nd floor hallway under carpet & under 12" vinyl floor tile in the 2 nd floor bedrooms	Category I non-friable	5% Chrysotile-Floor Tile 5% Chrysotile-Black Mastic	500 SF
16	White paper (heat shield) behind radiators	2 nd floor south bedroom west wall	RACM	30% Chrysotile	6 LF
Garage					
19	Exterior window glazing	Garage windows	Category II non-friable	2% Chrysotile	150 LF
22	Flashing material on brown roof shingles	Garage roof	Category I non-friable	5% Chrysotile	500 SF
23	Bottom flashing material on built-up roof	Garage car port roof	Category I non-friable	5% Chrysotile	450 SF

*Estimated quantities are based on a cursory field evaluation, and actual quantities may vary.

APPENDIX B (continued)

HA = homogeneous area

SF = square feet

LF = linear feet

RACM = Includes friable ACM, category I nonfriable ACM that has become friable, Category I nonfriable ACM that will be or has been subjected to sanding, grinding, cutting, or abrading, or category II nonfriable ACM that has a high probability of becoming or has become crumbled, pulverized, or reduced to powder by the forces expected to act on the material in the course of demolition or renovation operations.

Category I: Includes asbestos-containing packings, gaskets, asphaltic roofing products, resilient flooring, pliable sealants and pliable mastics

SHIPPING MANIFEST
Generator

1. Work Site Name and Mailing Address	Owner's Name	Owner's Telephone No.
2. Operator's Name and Address		Operator's Telephone No
3. Waste Disposal Site (WDS) Name Mailing Address, and Physical Site Location		WDS Telephone No.
4. Name and Address of Responsible Agency		
5. Description of Materials		
6. Containers	No.	Type
7. Total Quantity	M ³	(Yd ³)
8. Special Handling Instructions and Additional Information		
9. OPERATOR'S CERTIFICATION: I hereby declare that the contents of this consignment are fully and accurately described above by proper shipping name and are classified, packed, marked, and labeled, and are in all respects in proper condition for transport by highway according to applicable international and government regulations.		
Printed/Typed Name & Title	Signature	Month Day Year
Transporter		
10. Transporter 1 (Acknowledgement of Receipt of Materials)		
Printed/Typed Name & Title	Signature	Month Day Year
Address and Telephone No.		
11. Transporter 2 (Acknowledgement of Receipt of Materials)		
Printed/Typed Name & Title	Signature	Month Day Year
Address and Telephone No.		
Disposal Site		
12. Discrepancy Indication Space		
13. Waste Disposal Site Owner or Operator: Certification of Receipt of Asbestos Materials Covered By This Manifest Except As Noted in Item 12		
Printed/Typed Name & Title	Signature	Month Day Year

INSTRUCTIONS

Waste Generator Section (Items 1-9)

1. Enter the name of the facility at which asbestos waste is generated and the address where the facility is located. In the appropriate spaces, also enter the name of the owner of the facility and the owner's phone number.
2. If a demolition or renovation, enter the name and address of the Company and authorized agent responsible for performing the asbestos removal. In the appropriate spaces, also enter the phone number of the operator.
3. Enter the name, address, and physical site location of the waste disposal site (WDS) that will be receiving the asbestos materials. In the appropriate spaces, also enter the phone number of the WDS. Enter "on-site" if the waste will be disposed of on the generator's property.
4. Provide the name and address of the local, State, or EPA Regional Office responsible for administering the asbestos NESHAP program.
5. Indicate the types of asbestos waste materials generated. If from a demolition or renovation, indicate the amount of asbestos that is
 - Friable asbestos material
 - Nonfriable asbestos material
6. Enter the number of containers used to transport the asbestos materials listed in Item 5. Also enter one of the following container codes used in transporting each type of asbestos material (specify any other type of container used if not listed below):
 - DM - Metal drums, barrels
 - DP - Plastic drums, barrels
 - BA - 6 mil plastic bags or wrapping
7. Enter the quantities of each type of asbestos material removed in units of cubic meters (cubic yards).
8. Use this space to indicate special transportation, treatment, storage or disposal or Bill of Lading information. If an alternate waste disposal site is designated, note it here. Emergency response telephone numbers or similar information may be included here.
9. The authorized agent of the waste generator shall read and then sign and date this certification. The date is the date of receipt by transporter.

NOTE: The waste generator shall retain a copy of this form.

INSTRUCTIONS

Transporter Section (Items 10 & 11)

10. & 11. Enter name, address, and telephone number of each transporter used, if applicable. Print or type the full name and title of person accepting responsibility and acknowledging receipt of materials as listed on this waste shipment record for transport.

NOTE: The transporter shall retain a copy of this form.

Disposal Site Section (Items 12 & 13)

12. The authorized representative of the WDS shall note in this space any discrepancy between waste described on this manifest and waste actually received as well as any improperly enclosed or contained waste. Any rejected materials should be listed and destination of those materials provided. A site that converts asbestos-containing waste material to nonasbestos material is considered a WDS.
13. The signature (by hand) of the authorized WDS agent indicates acceptance and agreement with statements on this manifest except as noted in Item 12. The date is the date of signature and receipt of shipment.

NOTE: The WDS shall retain a completed copy of this form. The WDS shall also send a completed copy to the operator listed in Item 2.

COMPENSABLE DELAY COSTS (BDE)

Effective: June 2, 2017

Revised: April 1, 2019

Revise Article 107.40(b) of the Standard Specifications to read:

“(b) Compensation. Compensation will not be allowed for delays, inconveniences, or damages sustained by the Contractor from conflicts with facilities not meeting the above definition; or if a conflict with a utility in an unanticipated location does not cause a shutdown of the work or a documentable reduction in the rate of progress exceeding the limits set herein. The provisions of Article 104.03 notwithstanding, compensation for delays caused by a utility in an unanticipated location will be paid according to the provisions of this Article governing minor and major delays or reduced rate of production which are defined as follows.

- (1) Minor Delay. A minor delay occurs when the work in conflict with the utility in an unanticipated location is completely stopped for more than two hours, but not to exceed two weeks.
- (2) Major Delay. A major delay occurs when the work in conflict with the utility in an unanticipated location is completely stopped for more than two weeks.
- (3) Reduced Rate of Production Delay. A reduced rate of production delay occurs when the rate of production on the work in conflict with the utility in an unanticipated location decreases by more than 25 percent and lasts longer than seven calendar days.”

Revise Article 107.40(c) of the Standard Specifications to read:

“(c) Payment. Payment for Minor, Major, and Reduced Rate of Production Delays will be made as follows.

- (1) Minor Delay. Labor idled which cannot be used on other work will be paid for according to Article 109.04(b)(1) and (2) for the time between start of the delay and the minimum remaining hours in the work shift required by the prevailing practice in the area.

Equipment idled which cannot be used on other work, and which is authorized to standby on the project site by the Engineer, will be paid for according to Article 109.04(b)(4).

- (2) Major Delay. Labor will be the same as for a minor delay.

Equipment will be the same as for a minor delay, except Contractor-owned equipment will be limited to two weeks plus the cost of move-out to either the

Contractor's yard or another job and the cost to re-mobilize, whichever is less. Rental equipment may be paid for longer than two weeks provided the Contractor presents adequate support to the Department (including lease agreement) to show retaining equipment on the job is the most economical course to follow and in the public interest.

- (3) Reduced Rate of Production Delay. The Contractor will be compensated for the reduced productivity for labor and equipment time in excess of the 25 percent threshold for that portion of the delay in excess of seven calendar days. Determination of compensation will be in accordance with Article 104.02, except labor and material additives will not be permitted.

Payment for escalated material costs, escalated labor costs, extended project overhead, and extended traffic control will be determined according to Article 109.13.”

Revise Article 108.04(b) of the Standard Specifications to read:

“(b) No working day will be charged under the following conditions.

- (1) When adverse weather prevents work on the controlling item.
- (2) When job conditions due to recent weather prevent work on the controlling item.
- (3) When conduct or lack of conduct by the Department or its consultants, representatives, officers, agents, or employees; delay by the Department in making the site available; or delay in furnishing any items required to be furnished to the Contractor by the Department prevents work on the controlling item.
- (4) When delays caused by utility or railroad adjustments prevent work on the controlling item.
- (5) When strikes, lock-outs, extraordinary delays in transportation, or inability to procure critical materials prevent work on the controlling item, as long as these delays are not due to any fault of the Contractor.
- (6) When any condition over which the Contractor has no control prevents work on the controlling item.”

Revise Article 109.09(f) of the Standard Specifications to read:

“(f) Basis of Payment. After resolution of a claim in favor of the Contractor, any adjustment in time required for the work will be made according to Section 108. Any adjustment in the costs to be paid will be made for direct labor, direct materials, direct equipment, direct jobsite overhead, direct offsite overhead, and other direct costs allowed by the resolution. Adjustments in costs will not be made for interest charges, loss of anticipated profit, undocumented loss of efficiency, home office overhead and unabsorbed overhead

other than as allowed by Article 109.13, lost opportunity, preparation of claim expenses and other consequential indirect costs regardless of method of calculation.

The above Basis of Payment is an essential element of the contract and the claim cost recovery of the Contractor shall be so limited.”

Add the following to Section 109 of the Standard Specifications.

“109.13 Payment for Contract Delay. Compensation for escalated material costs, escalated labor costs, extended project overhead, and extended traffic control will be allowed when such costs result from a delay meeting the criteria in the following table.

Contract Type	Cause of Delay	Length of Delay
Working Days	Article 108.04(b)(3) or Article 108.04(b)(4)	No working days have been charged for two consecutive weeks.
Completion Date	Article 108.08(b)(1) or Article 108.08(b)(7)	The Contractor has been granted a minimum two week extension of contract time, according to Article 108.08.

Payment for each of the various costs will be according to the following.

- (a) Escalated Material and/or Labor Costs. When the delay causes work, which would have otherwise been completed, to be done after material and/or labor costs have increased, such increases will be paid. Payment for escalated material costs will be limited to the increased costs substantiated by documentation furnished by the Contractor. Payment for escalated labor costs will be limited to those items in Article 109.04(b)(1) and (2), except the 35 percent and 10 percent additives will not be permitted.
- (b) Extended Project Overhead. For the duration of the delay, payment for extended project overhead will be paid as follows.
 - (1) Direct Jobsite and Offsite Overhead. Payment for documented direct jobsite overhead and documented direct offsite overhead, including onsite supervisory and administrative personnel, will be allowed according to the following table.

Original Contract Amount	Supervisory and Administrative Personnel
Up to \$5,000,000	One Project Superintendent
Over \$ 5,000,000 - up to \$25,000,000	One Project Manager, One Project Superintendent or Engineer, and One Clerk
Over \$25,000,000 - up to \$50,000,000	One Project Manager, One Project Superintendent, One Engineer, and

	One Clerk
Over \$50,000,000	One Project Manager, Two Project Superintendents, One Engineer, and One Clerk

(2) Home Office and Unabsorbed Overhead. Payment for home office and unabsorbed overhead will be calculated as 8 percent of the total delay cost.

(c) Extended Traffic Control. Traffic control required for an extended period of time due to the delay will be paid for according to Article 109.04.

When an extended traffic control adjustment is paid under this provision, an adjusted unit price as provided for in Article 701.20(a) for increase or decrease in the value of work by more than ten percent will not be paid.

Upon payment for a contract delay under this provision, the Contractor shall assign subrogation rights to the Department for the Department's efforts of recovery from any other party for monies paid by the Department as a result of any claim under this provision. The Contractor shall fully cooperate with the Department in its efforts to recover from another party any money paid to the Contractor for delay damages under this provision."

80384

CONSTRUCTION AIR QUALITY – DIESEL RETROFIT (BDE)

Effective: June 1, 2010

Revised: November 1, 2014

The reduction of emissions of particulate matter (PM) for off-road equipment shall be accomplished by installing retrofit emission control devices. The term “equipment” refers to diesel fuel powered devices rated at 50 hp and above, to be used on the jobsite in excess of seven calendar days over the course of the construction period on the jobsite (including rental equipment).

Contractor and subcontractor diesel powered off-road equipment assigned to the contract shall be retrofitted using the phased in approach shown below. Equipment that is of a model year older than the year given for that equipment’s respective horsepower range shall be retrofitted:

Effective Dates	Horsepower Range	Model Year
June 1, 2010 ^{1/}	600-749	2002
	750 and up	2006
June 1, 2011 ^{2/}	100-299	2003
	300-599	2001
	600-749	2002
	750 and up	2006
June 1, 2012 ^{2/}	50-99	2004
	100-299	2003
	300-599	2001
	600-749	2002
	750 and up	2006

1/ Effective dates apply to Contractor diesel powered off-road equipment assigned to the contract.

2/ Effective dates apply to Contractor and subcontractor diesel powered off-road equipment assigned to the contract.

The retrofit emission control devices shall achieve a minimum PM emission reduction of 50 percent and shall be:

- a) Included on the U.S. Environmental Protection Agency (USEPA) *Verified Retrofit Technology List* (<http://www.epa.gov/cleandiesel/verification/verif-list.htm>), or verified by the California Air Resources Board (CARB) (<http://www.arb.ca.gov/diesel/verdev/vt/cvt.htm>); or
- b) Retrofitted with a non-verified diesel retrofit emission control device if verified retrofit emission control devices are not available for equipment proposed to be used on the project, and if the Contractor has obtained a performance certification from the retrofit

device manufacturer that the emission control device provides a minimum PM emission reduction of 50 percent.

Note: Large cranes (Crawler mounted cranes) which are responsible for critical lift operations are exempt from installing retrofit emission control devices if such devices adversely affect equipment operation.

Diesel powered off-road equipment with engine ratings of 50 hp and above, which are unable to be retrofitted with verified emission control devices or if performance certifications are not available which will achieve a minimum 50 percent PM reduction, may be granted a waiver by the Department if documentation is provided showing good faith efforts were made by the Contractor to retrofit the equipment.

Construction shall not proceed until the Contractor submits a certified list of the diesel powered off-road equipment that will be used, and as necessary, retrofitted with emission control devices. The list(s) shall include (1) the equipment number, type, make, Contractor/rental company name; and (2) the emission control devices make, model, USEPA or CARB verification number, or performance certification from the retrofit device manufacturer. Equipment reported as fitted with emissions control devices shall be made available to the Engineer for visual inspection of the device installation, prior to being used on the jobsite.

The Contractor shall submit an updated list of retrofitted off-road construction equipment as retrofitted equipment changes or comes on to the jobsite. The addition or deletion of any diesel powered equipment shall be included on the updated list.

If any diesel powered off-road equipment is found to be in non-compliance with any portion of this special provision, the Engineer will issue the Contractor a diesel retrofit deficiency deduction.

Any costs associated with retrofitting any diesel powered off-road equipment with emission control devices shall be considered as included in the contract unit prices bid for the various items of work involved and no additional compensation will be allowed. The Contractor's compliance with this notice and any associated regulations shall not be grounds for a claim.

Diesel Retrofit Deficiency Deduction

When the Engineer determines that a diesel retrofit deficiency exists, a daily monetary deduction will be imposed for each calendar day or fraction thereof the deficiency continues to exist. The calendar day(s) will begin when the time period for correction is exceeded and end with the Engineer's written acceptance of the correction. The daily monetary deduction will be \$1,000.00 for each deficiency identified.

The deficiency will be based on lack of diesel retrofit emissions control.

If a Contractor accumulates three diesel retrofit deficiency deductions for the same piece of equipment in a contract period, the Contractor will be shutdown until the deficiency is corrected.

Such a shutdown will not be grounds for any extension of the contract time, waiver of penalties, or be grounds for any claim.

80261

DISADVANTAGED BUSINESS ENTERPRISE PARTICIPATION (BDE)

Effective: September 1, 2000

Revised: March 2, 2019

FEDERAL OBLIGATION. The Department of Transportation, as a recipient of federal financial assistance, is required to take all necessary and reasonable steps to ensure nondiscrimination in the award and administration of contracts. Consequently, the federal regulatory provisions of 49 CFR Part 26 apply to this contract concerning the utilization of disadvantaged business enterprises. For the purposes of this Special Provision, a disadvantaged business enterprise (DBE) means a business certified by the Department in accordance with the requirements of 49 CFR Part 26 and listed in the Illinois Unified Certification Program (IL UCP) DBE Directory.

STATE OBLIGATION. This Special Provision will also be used by the Department to satisfy the requirements of the Business Enterprise for Minorities, Females, and Persons with Disabilities Act, 30 ILCS 575. When this Special Provision is used to satisfy state law requirements on 100 percent state-funded contracts, the federal government has no involvement in such contracts (not a federal-aid contract) and no responsibility to oversee the implementation of this Special Provision by the Department on those contracts. DBE participation on 100 percent state-funded contracts will not be credited toward fulfilling the Department's annual overall DBE goal required by the US Department of Transportation to comply with the federal DBE program requirements.

CONTRACTOR ASSURANCE. The Contractor makes the following assurance and agrees to include the assurance in each subcontract the Contractor signs with a subcontractor.

The Contractor, subrecipient, or subcontractor shall not discriminate on the basis of race, color, national origin, or sex in the performance of this contract. The Contractor shall carry out applicable requirements of 49 CFR Part 26 in the award and administration of contracts funded in whole or in part with federal or state funds. Failure by the Contractor to carry out these requirements is a material breach of this contract, which may result in the termination of this contract or such other remedy as the recipient deems appropriate, which may include, but is not limited to:

- (a) Withholding progress payments;
- (b) Assessing sanctions;
- (c) Liquidated damages; and/or
- (d) Disqualifying the Contractor from future bidding as non-responsible.

OVERALL GOAL SET FOR THE DEPARTMENT. As a requirement of compliance with 49 CFR Part 26, the Department has set an overall goal for DBE participation in its federally assisted contracts. That goal applies to all federal-aid funds the Department will expend in its federally assisted contracts for the subject reporting fiscal year. The Department is required to make a

good faith effort to achieve the overall goal. The dollar amount paid to all approved DBE companies performing work called for in this contract is eligible to be credited toward fulfillment of the Department's overall goal.

CONTRACT GOAL TO BE ACHIEVED BY THE CONTRACTOR. This contract includes a specific DBE utilization goal established by the Department. The goal has been included because the Department has determined the work of this contract has subcontracting opportunities that may be suitable for performance by DBE companies. The determination is based on an assessment of the type of work, the location of the work, and the availability of DBE companies to do a part of the work. The assessment indicates, in the absence of unlawful discrimination and in an arena of fair and open competition, DBE companies can be expected to perform 24.00 % of the work. This percentage is set as the DBE participation goal for this contract. Consequently, in addition to the other award criteria established for this contract, the Department will only award this contract to a bidder who makes a good faith effort to meet this goal of DBE participation in the performance of the work. A bidder makes a good faith effort for award consideration if either of the following is done in accordance with the procedures set for in this Special Provision:

- (a) The bidder documents enough DBE participation has been obtained to meet the goal or,
- (b) The bidder documents a good faith effort has been made to meet the goal, even though the effort did not succeed in obtaining enough DBE participation to meet the goal.

DBE LOCATOR REFERENCES. Bidders shall consult the IL UCP DBE Directory as a reference source for DBE-certified companies. In addition, the Department maintains a letting and item specific DBE locator information system whereby DBE companies can register their interest in providing quotes on particular bid items advertised for letting. Information concerning DBE companies willing to quote work for particular contracts may be obtained by contacting the Department's Bureau of Small Business Enterprises at telephone number (217) 785-4611, or by visiting the Department's website at:

<http://www.idot.illinois.gov/doing-business/certifications/disadvantaged-business-enterprise-certification/il-ucp-directory/index>.

BIDDING PROCEDURES. Compliance with this Special Provision is a material bidding requirement and failure of the bidder to comply will render the bid not responsive.

The bidder shall submit a DBE Utilization Plan (form SBE 2026), and a DBE Participation Statement (form SBE 2025) for each DBE company proposed for the performance of work to achieve the contract goal, with the bid. If the Utilization Plan indicates the contract goal will not be met, documentation of good faith efforts shall also be submitted. The documentation of good faith efforts must include copies of each DBE and non-DBE subcontractor quote submitted to the bidder when a non-DBE subcontractor is selected over a DBE for work on the contract. The required forms and documentation must be submitted as a single .pdf file using the "Integrated Contractor Exchange (iCX)" application within the Department's "EBids System".

The Department will not accept a Utilization Plan if it does not meet the bidding procedures set forth herein and the bid will be declared not responsive. In the event the bid is declared not responsive, the Department may elect to cause the forfeiture of the penal sum of the bidder's proposal guaranty and may deny authorization to bid the project if re-advertised for bids.

GOOD FAITH EFFORT PROCEDURES. The contract will not be awarded until the Utilization Plan is approved. All information submitted by the bidder must be complete, accurate and adequately document enough DBE participation has been obtained or document the good faith efforts of the bidder, in the event enough DBE participation has not been obtained, before the Department will commit to the performance of the contract by the bidder. The Utilization Plan will be approved by the Department if the Utilization Plan documents sufficient commercially useful DBE work to meet the contract goal or the bidder submits sufficient documentation of a good faith effort to meet the contract goal pursuant to 49 CFR Part 26, Appendix A. This means the bidder must show that all necessary and reasonable steps were taken to achieve the contract goal. Necessary and reasonable steps are those which, by their scope, intensity and appropriateness to the objective, could reasonably be expected to obtain sufficient DBE participation, even if they were not successful. The Department will consider the quality, quantity, and intensity of the kinds of efforts the bidder has made. Mere *pro forma* efforts, in other words efforts done as a matter of form, are not good faith efforts; rather, the bidder is expected to have taken genuine efforts that would be reasonably expected of a bidder actively and aggressively trying to obtain DBE participation sufficient to meet the contract goal.

- (a) The following is a list of types of action that the Department will consider as part of the evaluation of the bidder's good faith efforts to obtain participation. These listed factors are not intended to be a mandatory checklist and are not intended to be exhaustive. Other factors or efforts brought to the attention of the Department may be relevant in appropriate cases and will be considered by the Department.
 - (1) Soliciting through all reasonable and available means (e.g. attendance at pre-bid meetings, advertising and/or written notices) the interest of all certified DBE companies that have the capability to perform the work of the contract. The bidder must solicit this interest within sufficient time to allow the DBE companies to respond to the solicitation. The bidder must determine with certainty if the DBE companies are interested by taking appropriate steps to follow up initial solicitations.
 - (2) Selecting portions of the work to be performed by DBE companies in order to increase the likelihood that the DBE goals will be achieved. This includes, where appropriate, breaking out contract work items into economically feasible units to facilitate DBE participation, even when the Contractor might otherwise prefer to perform these work items with its own forces.
 - (3) Providing interested DBE companies with adequate information about the plans, specifications, and requirements of the contract in a timely manner to assist them in responding to a solicitation.

- (4) a. Negotiating in good faith with interested DBE companies. It is the bidder's responsibility to make a portion of the work available to DBE subcontractors and suppliers and to select those portions of the work or material needs consistent with the available DBE subcontractors and suppliers, so as to facilitate DBE participation. Evidence of such negotiation includes the names, addresses, and telephone numbers of DBE companies that were considered; a description of the information provided regarding the plans and specifications for the work selected for subcontracting; and evidence as to why additional agreements could not be reached for DBE companies to perform the work.
 - b. A bidder using good business judgment would consider a number of factors in negotiating with subcontractors, including DBE subcontractors, and would take a firm's price and capabilities as well as contract goals into consideration. However, the fact that there may be some additional costs involved in finding and using DBE companies is not in itself sufficient reason for a bidder's failure to meet the contract DBE goal, as long as such costs are reasonable. Also the ability or desire of a bidder to perform the work of a contract with its own organization does not relieve the bidder of the responsibility to make good faith efforts. Bidders are not, however, required to accept higher quotes from DBE companies if the price difference is excessive or unreasonable. In accordance with the above Bidding Procedures, the documentation of good faith efforts must include copies of each DBE and non-DBE subcontractor quote submitted to the bidder when a non-DBE subcontractor was selected over a DBE for work on the contract.
- (5) Not rejecting DBE companies as being unqualified without sound reasons based on a thorough investigation of their capabilities. The bidder's standing within its industry, membership in specific groups, organizations, or associations and political or social affiliations (for example union vs. non-union employee status) are not legitimate causes for the rejection or non-solicitation of bids in the bidder's efforts to meet the project goal.
 - (6) Making efforts to assist interested DBE companies in obtaining bonding, lines of credit, or insurance as required by the recipient or Contractor.
 - (7) Making efforts to assist interested DBE companies in obtaining necessary equipment, supplies, materials, or related assistance or services.
 - (8) Effectively using the services of available minority/women community organizations; minority/women contractors' groups; local, state, and federal minority/women business assistance offices; and other organizations as allowed on a case-by-case basis to provide assistance in the recruitment and placement of DBE companies.
- (b) If the Department determines the bidder has made a good faith effort to secure the work commitment of DBE companies to meet the contract goal, the Department will award the contract provided it is otherwise eligible for award. If the Department determines the

bidder has failed to meet the requirements of this Special Provision or that a good faith effort has not been made, the Department will notify the responsible company official designated in the Utilization Plan that the bid is not responsive. The notification will also include a statement of reasons for the adverse determination. If the Utilization Plan is not approved because it is deficient as a technical matter, unless waived by the Department, the bidder will be notified and will be allowed no more than a five calendar day period to cure the deficiency.

- (c) The bidder may request administrative reconsideration of an adverse determination by emailing the Department at "DOT.DBE.UP@illinois.gov" within the five calendar days after the receipt of the notification of the determination. The determination shall become final if a request is not made on or before the fifth calendar day. A request may provide additional written documentation or argument concerning the issues raised in the determination statement of reasons, provided the documentation and arguments address efforts made prior to submitting the bid. The request will be reviewed by the Department's Reconsideration Officer. The Reconsideration Officer will extend an opportunity to the bidder to meet in person to consider all issues of documentation and whether the bidder made a good faith effort to meet the goal. After the review by the Reconsideration Officer, the bidder will be sent a written decision within ten working days after receipt of the request for reconsideration, explaining the basis for finding that the bidder did or did not meet the goal or make adequate good faith efforts to do so. A final decision by the Reconsideration Officer that a good faith effort was made shall approve the Utilization Plan submitted by the bidder and shall clear the contract for award. A final decision that a good faith effort was not made shall render the bid not responsive.

CALCULATING DBE PARTICIPATION. The Utilization Plan values represent work anticipated to be performed and paid for upon satisfactory completion. The Department is only able to count toward the achievement of the overall goal and the contract goal the value of payments made for the work actually performed by DBE companies. In addition, a DBE must perform a commercially useful function on the contract to be counted. A commercially useful function is generally performed when the DBE is responsible for the work and is carrying out its responsibilities by actually performing, managing, and supervising the work involved. The Department and Contractor are governed by the provisions of 49 CFR Part 26.55(c) on questions of commercially useful functions as it affects the work. Specific counting guidelines are provided in 49 CFR Part 26.55, the provisions of which govern over the summary contained herein.

- (a) DBE as the Contractor: 100 percent goal credit for that portion of the work performed by the DBE's own forces, including the cost of materials and supplies. Work that a DBE subcontracts to a non-DBE does not count toward the DBE goals.
- (b) DBE as a joint venture Contractor: 100 percent goal credit for that portion of the total dollar value of the contract equal to the distinct, clearly defined portion of the work performed by the DBE's own forces.

- (c) DBE as a subcontractor: 100 percent goal credit for the work of the subcontract performed by the DBE's own forces, including the cost of materials and supplies, excluding the purchase of materials and supplies or the lease of equipment by the DBE subcontractor from the Contractor or its affiliates. Work that a DBE subcontractor in turn subcontracts to a non-DBE does not count toward the DBE goal.
- (d) DBE as a trucker: 100 percent goal credit for trucking participation provided the DBE is responsible for the management and supervision of the entire trucking operation for which it is responsible. At least one truck owned, operated, licensed, and insured by the DBE must be used on the contract. Credit will be given for the following:
 - (1) The DBE may lease trucks from another DBE firm, including an owner-operator who is certified as a DBE. The DBE who leases trucks from another DBE receives credit for the total value of the transportation services the lessee DBE provides on the contract.
 - (2) The DBE may also lease trucks from a non-DBE firm, including from an owner-operator. The DBE who leases trucks from a non-DBE is entitled to credit only for the fee or commission is receives as a result of the lease arrangement.
- (e) DBE as a material supplier:
 - (1) 60 percent goal credit for the cost of the materials or supplies purchased from a DBE regular dealer.
 - (2) 100 percent goal credit for the cost of materials of supplies obtained from a DBE manufacturer.
 - (3) 100 percent credit for the value of reasonable fees and commissions for the procurement of materials and supplies if not a DBE regular dealer or DBE manufacturer.

CONTRACT COMPLIANCE. Compliance with this Special Provision is an essential part of the contract. The Department is prohibited by federal regulations from crediting the participation of a DBE included in the Utilization Plan toward either the contract goal or the Department's overall goal until the amount to be applied toward the goals has been paid to the DBE. The following administrative procedures and remedies govern the compliance by the Contractor with the contractual obligations established by the Utilization Plan. After approval of the Utilization Plan and award of the contract, the Utilization Plan and individual DBE Participation Statements become part of the contract. If the Contractor did not succeed in obtaining enough DBE participation to achieve the advertised contract goal, and the Utilization Plan was approved and contract awarded based upon a determination of good faith, the total dollar value of DBE work calculated in the approved Utilization Plan as a percentage of the awarded contract value shall become the amended contract goal. All work indicated for performance by an approved DBE shall be performed, managed, and supervised by the DBE executing the DBE Participation Commitment Statement.

- (a) NO AMENDMENT. No amendment to the Utilization Plan may be made without prior written approval from the Department's Bureau of Small Business Enterprises. All requests for amendment to the Utilization Plan shall be emailed to the Department at DOT.DBE.UP@illinois.gov.
- (b) CHANGES TO WORK. Any deviation from the DBE condition-of-award or contract plans, specifications, or special provisions must be approved, in writing, by the Department as provided elsewhere in the Contract. The Contractor shall notify affected DBEs in writing of any changes in the scope of work which result in a reduction in the dollar amount condition-of-award to the contract. Where the revision includes work committed to a new DBE subcontractor, not previously involved in the project, then a Request for Approval of Subcontractor, Department form BC 260A or AER 260A, must be signed and submitted. If the commitment of work is in the form of additional tasks assigned to an existing subcontract, a new Request for Approval of Subcontractor will not be required. However, the Contractor must document efforts to assure the existing DBE subcontractor is capable of performing the additional work and has agreed in writing to the change.
- (c) SUBCONTRACT. The Contractor must provide copies of DBE subcontracts to the Department upon request. Subcontractors shall ensure that all lower tier subcontracts or agreements with DBEs to supply labor or materials be performed in accordance with this Special Provision.
- (d) ALTERNATIVE WORK METHODS. In addition to the above requirements for reductions in the condition of award, additional requirements apply to the two cases of Contractor-initiated work substitution proposals. Where the contract allows alternate work methods which serve to delete or create underruns in condition of award DBE work, and the Contractor selects that alternate method or, where the Contractor proposes a substitute work method or material that serves to diminish or delete work committed to a DBE and replace it with other work, then the Contractor must demonstrate one of the following:
- (1) The replacement work will be performed by the same DBE (as long as the DBE is certified in the respective item of work) in a modification of the condition of award; or
 - (2) The DBE is aware its work will be deleted or will experience underruns and has agreed in writing to the change. If this occurs, the Contractor shall substitute other work of equivalent value to a certified DBE or provide documentation of good faith efforts to do so; or
 - (3) The DBE is not capable of performing the replacement work or has declined to perform the work at a reasonable competitive price. If this occurs, the Contractor shall substitute other work of equivalent value to a certified DBE or provide documentation of good faith efforts to do so.

- (e) TERMINATION AND REPLACEMENT PROCEDURES. The Contractor shall not terminate or replace a DBE listed on the approved Utilization Plan, or perform with other forces work designated for a listed DBE except as provided in this Special Provision. The Contractor shall utilize the specific DBEs listed to perform the work and supply the materials for which each is listed unless the Contractor obtains the Department's written consent as provided in subsection (a) of this part. Unless Department consent is provided for termination of a DBE subcontractor, the Contractor shall not be entitled to any payment for work or material unless it is performed or supplied by the DBE in the Utilization Plan.

As stated above, the Contractor shall not terminate or replace a DBE subcontractor listed in the approved Utilization Plan without prior written consent. This includes, but is not limited to, instances in which the Contractor seeks to perform work originally designated for a DBE subcontractor with its own forces or those of an affiliate, a non-DBE firm, or with another DBE firm. Written consent will be granted only if the Bureau of Small Business Enterprises agrees, for reasons stated in its concurrence document, that the Contractor has good cause to terminate or replace the DBE firm. Before transmitting to the Bureau of Small Business Enterprises any request to terminate and/or substitute a DBE subcontractor, the Contractor shall give notice in writing to the DBE subcontractor, with a copy to the Bureau, of its intent to request to terminate and/or substitute, and the reason for the request. The Contractor shall give the DBE five days to respond to the Contractor's notice. The DBE so notified shall advise the Bureau and the Contractor of the reasons, if any, why it objects to the proposed termination of its subcontract and why the Bureau should not approve the Contractor's action. If required in a particular case as a matter of public necessity, the Bureau may provide a response period shorter than five days.

For purposes of this paragraph, good cause includes the following circumstances:

- (1) The listed DBE subcontractor fails or refuses to execute a written contract;
- (2) The listed DBE subcontractor fails or refuses to perform the work of its subcontract in a way consistent with normal industry standards. Provided, however, that good cause does not exist if the failure or refusal of the DBE subcontractor to perform its work on the subcontract results from the bad faith or discriminatory action of the Contractor;
- (3) The listed DBE subcontractor fails or refuses to meet the Contractor's reasonable, nondiscriminatory bond requirements;
- (4) The listed DBE subcontractor becomes bankrupt, insolvent, or exhibits credit unworthiness;
- (5) The listed DBE subcontractor is ineligible to work on public works projects because of suspension and debarment proceedings pursuant 2 CFR Parts 180, 215 and 1200 or applicable state law.

- (6) The Contractor has determined the listed DBE subcontractor is not a responsible contractor;
- (7) The listed DBE subcontractor voluntarily withdraws from the projects and provides written notice to the Contractor of its withdrawal;
- (8) The listed DBE is ineligible to receive DBE credit for the type of work required;
- (9) A DBE owner dies or becomes disabled with the result that the listed DBE subcontractor is unable to complete its work on the contract;
- (10) Other documented good cause that compels the termination of the DBE subcontractor. Provided, that good cause does not exist if the Contractor seeks to terminate a DBE it relied upon to obtain the contract so that the Contractor can self-perform the work for which the DBE contractor was engaged or so that the Contractor can substitute another DBE or non-DBE contractor after contract award.

When a DBE is terminated or fails to complete its work on the Contract for any reason, the Contractor shall make a good faith effort to find another DBE to substitute for the original DBE to perform at least the same amount of work under the contract as the terminated DBE to the extent needed to meet the established Contract goal. The good faith efforts shall be documented by the Contractor. If the Department requests documentation under this provision, the Contractor shall submit the documentation within seven days, which may be extended for an additional seven days if necessary at the request of the Contractor. The Department will provide a written determination to the Contractor stating whether or not good faith efforts have been demonstrated.

- (f) FINAL PAYMENT. After the performance of the final item of work or delivery of material by a DBE and final payment therefore to the DBE by the Contractor, but not later than 30 calendar days after payment has been made by the Department to the Contractor for such work or material, the Contractor shall submit a DBE Payment Agreement on Department form SBE 2115 to the Resident Engineer. If full and final payment has not been made to the DBE, the DBE Payment Agreement shall indicate whether a disagreement as to the payment required exists between the Contractor and the DBE or if the Contractor believes the work has not been satisfactorily completed. If the Contractor does not have the full amount of work indicated in the Utilization Plan performed by the DBE companies indicated in the Utilization Plan and after good faith efforts are reviewed, the Department may deduct from contract payments to the Contractor the amount of the goal not achieved as liquidated and ascertained damages. The Contractor may request an administrative reconsideration of any amount deducted as damages pursuant to subsection (h) of this part.
- (g) ENFORCEMENT. The Department reserves the right to withhold payment to the Contractor to enforce the provisions of this Special Provision. Final payment shall not be

made on the contract until such time as the Contractor submits sufficient documentation demonstrating achievement of the goal in accordance with this Special Provision or after liquidated damages have been determined and collected.

- (h) RECONSIDERATION. Notwithstanding any other provision of the contract, including but not limited to Article 109.09 of the Standard Specifications, the Contractor may request administrative reconsideration of a decision to deduct the amount of the goal not achieved as liquidated damages. A request to reconsider shall be delivered to the Contract Compliance Section and shall be handled and considered in the same manner as set forth in paragraph (c) of “Good Faith Effort Procedures” of this Special Provision, except a final decision that a good faith effort was not made during contract performance to achieve the goal agreed to in the Utilization Plan shall be the final administrative decision of the Department. The result of the reconsideration process is not administratively appealable to the U.S. Department of Transportation.

80029

DISPOSAL FEES (BDE)

Effective: November 1, 2018

Replace Articles 109.04(b)(5) – 109.04(b)(8) of the Standard Specifications with the following:

- “(5) Disposal Fees. When the extra work performed includes paying for disposal fees at a clean construction and demolition debris facility, an uncontaminated soil fill operation or a landfill, the Contractor shall receive, as administrative costs, an amount equal to five percent of the first \$10,000 and one percent of any amount over \$10,000 of the total approved costs of such fees.
- (6) Miscellaneous. No additional allowance will be made for general superintendence, the use of small tools, or other costs for which no specific allowance is herein provided.
- (7) Statements. No payment will be made for work performed on a force account basis until the Contractor has furnished the Engineer with itemized statements of the cost of such force account work. Statements shall be accompanied and supported by invoices for all materials used and transportation charges. However, if materials used on the force account work are not specifically purchased for such work but are taken from the Contractor’s stock, then in lieu of the invoices, the Contractor shall furnish an affidavit certifying that such materials were taken from his/her stock, that the quantity claimed was actually used, and that the price and transportation claimed represent the actual cost to the Contractor.

Itemized statements at the cost of force account work shall be detailed as follows.

- a. Name, classification, date, daily hours, total hours, rate, and extension for each laborer and foreman. Payrolls shall be submitted to substantiate actual wages paid if so requested by the Engineer.
 - b. Designation, dates, daily hours, total hours, rental rate, and extension for each unit of machinery and equipment.
 - c. Quantities of materials, prices and extensions.
 - d. Transportation of materials.
 - e. Cost of property damage, liability and workmen’s compensation insurance premiums, unemployment insurance contributions, and social security tax.
- (8) Work Performed by an Approved Subcontractor. When extra work is performed by an approved subcontractor, the Contractor shall receive, as administrative costs, an amount equal to five percent of the total approved costs of such work with the minimum payment being \$100.

- (9) All statements of the cost of force account work shall be furnished to the Engineer not later than 60 days after receipt of the Central Bureau of Construction form "Extra Work Daily Report". If the statement is not received within the specified time frame, all demands for payment for the extra work are waived and the Department is released from any and all such demands. It is the responsibility of the Contractor to ensure that all statements are received within the specified time regardless of the manner or method of delivery."

80402

EMULSIFIED ASPHALTS (BDE)

Effective: August 1, 2019

Revise Article 1032.06 of the Standard Specifications to read:

“1032.06 Emulsified Asphalts. Emulsified asphalts will be accepted according to the current Bureau of Materials Policy Memorandum, “Emulsified Asphalt Acceptance Procedure”. These materials shall be homogeneous and shall show no separation of asphalt after thorough mixing, within 30 days after delivery, provided separation has not been caused by freezing. They shall coat the aggregate being used in the work to the satisfaction of the Engineer and shall be according to the following requirements.

- (a) Anionic Emulsified Asphalt. Anionic emulsified asphalts RS-1, RS-2, HFRS-2, SS-1h, and SS-1 shall be according to AASHTO M 140, except as follows.
 - (1) The cement mixing test will be waived when the emulsion is being used as a tack coat.
 - (2) The Solubility in Trichloroethylene test according to AASHTO T 44 may be run in lieu of Ash Content and shall meet a minimum of 97.5 percent.
- (b) Cationic Emulsified Asphalt. Cationic emulsified asphalts CRS-1, CRS-2, CSS-1h, and CSS-1 shall be according to AASHTO M 208, except as follows.
 - (1) The cement mixing test will be waived when the emulsion is being used as a tack coat.
 - (2) The Solubility in Trichloroethylene test according to AASHTO T 44 may be run in lieu of Ash Content and shall meet a minimum of 97.5 percent.
- (c) High Float Emulsion. High float emulsions HFE-90, HFE-150, and HFE-300 are medium setting and shall be according to the following table.

Test	HFE-90	HFE-150	HFE-300
Viscosity, Saybolt Furol, at 122 °F (50 °C), (AASHTO T 59), SFS ^{1/}	50 min.	50 min.	50 min.
Sieve Test, No. 20 (850 µm), retained on sieve, (AASHTO T 59), %	0.10 max.	0.10 max.	0.10 max.
Storage Stability Test, 1 day, (AASHTO T 59), %	1 max.	1 max.	1 max.
Coating Test (All Grades), (AASHTO T 59), 3 minutes	stone coated thoroughly		
Distillation Test, (AASHTO T 59): Residue from distillation test to 500 °F (260 °C), % Oil distillate by volume, %	65 min. 7 max.	65 min. 7 max.	65 min. 7 max.

Characteristics of residue from distillation test to 500 °F (260 °C): Penetration at 77 °F (25 °C), (AASHTO T 49), 100 g, 5 sec, dmm	90-150	150-300	300 min.
Float Test at 140 °F (60 °C), (AASHTO T 50), sec.	1200 min.	1200 min.	1200 min.

1/ The emulsion shall be pumpable.

- (d) Penetrating Emulsified Prime. Penetrating Emulsified Prime (PEP) shall be according to AASHTO T 59, except as follows.

Test	Result
Viscosity, Saybolt Furol, at 77 °F (25 °C), SFS	75 max.
Sieve test, retained on No. 20 (850 µm) sieve, %	0.10 max.
Distillation to 500 °F (260 °C) residue, %	38 min.
Oil distillate by volume, %	4 max.

The PEP shall be tested according to the current Bureau of Materials Illinois Laboratory Test Procedure (ILTP), "Sand Penetration Test of Penetrating Emulsified Prime (PEP)". The time of penetration shall be equal to or less than that of MC-30. The depth of penetration shall be equal to or greater than that of MC-30.

- (e) Delete this subparagraph.
- (f) Polymer Modified Emulsified Asphalt. Polymer modified emulsified asphalts, e.g. SS-1hP, CSS-1hP, CRS-2P (formerly CRSP), CQS-1hP (formerly CSS-1h Latex Modified) and HFRS-2P (formerly HFP) shall be according to AASHTO M 316, except as follows.
- (1) The cement mixing test will be waived when the polymer modified emulsion is being used as a tack coat.
 - (2) CQS-1hP (formerly CSS-1h Latex Modified) emulsion for micro-surfacing treatments shall use latex as the modifier.
 - (3) Upon examination of the storage stability test cylinder after standing undisturbed for 24 hours, the surface shall show minimal to no white, milky colored substance and shall be a homogenous brown color throughout.
 - (4) The distillation for all polymer modified emulsions shall be performed according to AASHTO T 59, except the temperature shall be 374 ± 9 °F (190 ± 5 °C) to be held for a period of 15 minutes and measured using an ASTM 16F (16C) thermometer.
 - (5) The specified temperature for the Elastic Recovery test for all polymer modified emulsions shall be 50.0 ± 1.0 °F (10.0 ± 0.5 °C).

(6) The Solubility in Trichloroethylene test according to AASHTO T 44 may be run in lieu of Ash Content and shall meet a minimum of 97.5 percent.

(g) Non-Tracking Emulsified Asphalt. Non-tracking emulsified asphalt NTEA (formerly SS-1vh) shall be according to the following.

Test	Requirement
Saybolt Viscosity at 77 °F (25 °C), (AASHTO T 59), SFS	20-100
Storage Stability Test, 24 hr, (AASHTO T 59), %	1 max.
Residue by Distillation, 500 ± 10 °F (260 ± 5 °C), or Residue by Evaporation, 325 ± 5 °F (163 ± 3 °C), (AASHTO T 59), %	50 min.
Sieve Test, No. 20 (850 µm), (AASHTO T 59), %	0.3 max.
Tests on Residue from Evaporation	
Penetration at 77 °F (25 °C), 100 g, 5 sec, (AASHTO T 49), dmm	40 max.
Softening Point, (AASHTO T 53), °F (°C)	135 (57) min.
Ash Content, (AASHTO T 111), % ^{1/}	1 max.

1/ The Solubility in Trichloroethylene test according to AASHTO T 44 may be run in lieu of Ash Content and shall meet a minimum of 97.5 percent

The different grades are, in general, used for the following.

Grade	Use
SS-1, SS-1h, RS-1, RS-2, CSS-1, CRS-1, CRS-2, CSS-1h, HFE-90, SS-1hP, CSS-1hP, NTEA (formerly SS-1vh)	Tack Coat
PEP	Prime Coat
RS-2, HFE-90, HFE-150, HFE-300, CRS-2P (formerly CRSP), HFRS-2P (formerly HFP), CRS-2, HFRS-2	Bituminous Surface Treatment
CQS-1hP (formerly CSS-1h Latex Modified)	Micro-Surfacing Slurry Sealing Cape Seal"

80415

EQUIPMENT PARKING AND STORAGE (BDE)

Effective: November 1, 2017

Replace the first paragraph of Article 701.11 of the Standard Specifications with the following.

“701.11 Equipment Parking and Storage. During working hours, all vehicles and/or nonoperating equipment which are parked, two hours or less, shall be parked at least 8 ft (2.5 m) from the open traffic lane. For other periods of time during working and for all nonworking hours, all vehicles, materials, and equipment shall be parked or stored as follows.

- (a) When the project has adequate right-of-way, vehicles, materials, and equipment shall be located a minimum of 30 ft (9 m) from the pavement.
- (b) When adequate right-of-way does not exist, vehicles, materials, and equipment shall be located a minimum of 15 ft (4.5 m) from the edge of any pavement open to traffic.
- (c) Behind temporary concrete barrier, vehicles, materials, and equipment shall be located a minimum of 24 in. (600 mm) behind free standing barrier or a minimum of 6 in. (150 mm) behind barrier that is either pinned or restrained according to Article 704.04. The 24 in. or 6 in. measurement shall be from the base of the non-traffic side of the barrier.
- (d) Behind other man-made or natural barriers meeting the approval of the Engineer.”

80388

FUEL COST ADJUSTMENT (BDE)

Effective: April 1, 2009

Revised: August 1, 2017

Description. Fuel cost adjustments will be made to provide additional compensation to the Contractor, or a credit to the Department, for fluctuations in fuel prices when optioned by the Contractor. The bidder shall indicate with their bid whether or not this special provision will be part of the contract. Failure to indicate "Yes" for any category of work will make that category of work exempt from fuel cost adjustment.

General. The fuel cost adjustment shall apply to contract pay items as grouped by category. The adjustment shall only apply to those categories of work checked "Yes", and only when the cumulative plan quantities for a category exceed the required threshold. Adjustments to work items in a category, either up or down, and extra work paid for by agreed unit price will be subject to fuel cost adjustment only when the category representing the added work was subject to the fuel cost adjustment. Extra work paid for at a lump sum price or by force account will not be subject to fuel cost adjustment. Category descriptions and thresholds for application and the fuel usage factors which are applicable to each are as follows:

(a) Categories of Work.

- (1) Category A: Earthwork. Contract pay items performed under Sections 202, 204, and 206 including any modified standard or nonstandard items where the character of the work to be performed is considered earthwork. The cumulative total of all applicable item plan quantities shall exceed 25,000 cu yd (20,000 cu m). Included in the fuel usage factor is a weighted average 0.10 gal/cu yd (0.50 liters/cu m) factor for trucking.
- (2) Category B: Subbases and Aggregate Base Courses. Contract pay items constructed under Sections 311, 312 and 351 including any modified standard or nonstandard items where the character of the work to be performed is considered construction of a subbase or aggregate, stabilized or modified base course. The cumulative total of all applicable item plan quantities shall exceed 5000 tons (4500 metric tons). Included in the fuel usage factor is a 0.60 gal/ton (2.50 liters/metric ton) factor for trucking.
- (3) Category C: Hot-Mix Asphalt (HMA) Bases, Pavements and Shoulders. Contract pay items constructed under Sections 355, 406, 407 and 482 including any modified standard or nonstandard items where the character of the work to be performed is considered HMA bases, pavements and shoulders. The cumulative total of all applicable item plan quantities shall exceed 5000 tons (4500 metric tons). Included in the fuel usage factor is 0.60 gal/ton (2.50 liters/metric ton) factor for trucking.
- (4) Category D: Portland Cement Concrete (PCC) Bases, Pavements and Shoulders. Contract pay items constructed under Sections 353, 420, 421 and 483 including any

modified standard or nonstandard items where the character of the work to be performed is considered PCC base, pavement or shoulder. The cumulative total of all applicable item plan quantities shall exceed 7500 sq yd (6000 sq m). Included in the fuel usage factor is 1.20 gal/cu yd (5.94 liters/cu m) factor for trucking.

- (5) Category E: Structures. Structure items having a cumulative bid price that exceeds \$250,000 for pay items constructed under Sections 502, 503, 504, 505, 512, 516 and 540 including any modified standard or nonstandard items where the character of the work to be performed is considered structure work when similar to that performed under these sections and not included in categories A through D.

(b) Fuel Usage Factors.

English Units Category	Factor	Units
A - Earthwork	0.34	gal / cu yd
B – Subbase and Aggregate Base courses	0.62	gal / ton
C – HMA Bases, Pavements and Shoulders	1.05	gal / ton
D – PCC Bases, Pavements and Shoulders	2.53	gal / cu yd
E – Structures	8.00	gal / \$1000

Metric Units Category	Factor	Units
A - Earthwork	1.68	liters / cu m
B – Subbase and Aggregate Base courses	2.58	liters / metric ton
C – HMA Bases, Pavements and Shoulders	4.37	liters / metric ton
D – PCC Bases, Pavements and Shoulders	12.52	liters / cu m
E – Structures	30.28	liters / \$1000

(c) Quantity Conversion Factors.

Category	Conversion	Factor
B	sq yd to ton	0.057 ton / sq yd / in depth
	sq m to metric ton	0.00243 metric ton / sq m / mm depth
C	sq yd to ton	0.056 ton / sq yd / in depth
	sq m to metric ton	0.00239 m ton / sq m / mm depth
D	sq yd to cu yd	0.028 cu yd / sq yd / in depth
	sq m to cu m	0.001 cu m / sq m / mm depth

Method of Adjustment. Fuel cost adjustments will be computed as follows.

$$CA = (FPI_P - FPI_L) \times FUF \times Q$$

Where: CA = Cost Adjustment, \$
FPI_P = Fuel Price Index, as published by the Department for the month the work is performed, \$/gal (\$/liter)
FPI_L = Fuel Price Index, as published by the Department for the month prior to the letting for work paid for at the contract price; or for the month the agreed unit price letter is submitted by the Contractor for extra work paid for by agreed unit price, \$/gal (\$/liter)
FUF = Fuel Usage Factor in the pay item(s) being adjusted
Q = Authorized construction Quantity, tons (metric tons) or cu yd (cu m)

The entire FUF indicated in paragraph (b) will be used regardless of use of trucking to perform the work.

Basis of Payment. Fuel cost adjustments may be positive or negative but will only be made when there is a difference between the FPI_L and FPI_P in excess of five percent, as calculated by:

$$\text{Percent Difference} = \{(FPI_L - FPI_P) \div FPI_L\} \times 100$$

Fuel cost adjustments will be calculated for each calendar month in which applicable work is performed; and will be paid or deducted when all other contract requirements for the items of work are satisfied. The adjustments shall not apply during contract time subject to liquidated damages for completion of the entire contract.

80229

GROOVING FOR RECESSED PAVEMENT MARKINGS (BDE)

Effective: November 1, 2012

Revised: November 1, 2017

Description. This work shall consist of grooving the pavement surface in preparation for the application of recessed pavement markings.

Equipment. Equipment shall be according to the following.

- (a) Preformed Plastic Pavement Marking Installations. The grooving equipment shall have a free-floating saw blade cutting head equipped with gang-stacked diamond saw blades. The diamond saw blades shall be of uniform wear and shall produce a smooth textured surface. Any ridges in the groove shall have a maximum height of 15 mils (0.38 mm).
- (b) Liquid and Thermoplastic Pavement Marking Installations. The grooving equipment shall be equipped with either a free-floating saw blade cutting head or a free-floating grinder cutting head configuration with diamond or carbide tipped cutters and shall produce an irregular textured surface.

CONSTRUCTION REQUIREMENTS

General. The Contractor shall supply the Engineer with a copy of the pavement marking material manufacturer's recommendations for constructing a groove.

Pavement Grooving Methods. The grooves for recessed pavement markings shall be constructed using the following methods.

- (a) Wet Cutting Head Operation. When water is required or used to cool the cutting head, the groove shall be flushed with high pressure water immediately following the cut to avoid build up and hardening of slurry in the groove. The pavement surface shall be allowed to dry for a minimum of 24 hours prior to the final cleaning of the groove and application of the pavement marking material.
- (b) Dry Cutting Head Operation. When used on HMA pavements, the groove shall be vacuumed or cleaned by blasting with high-pressure air to remove loose aggregate, debris, and dust generated during the cutting operation. When used on PCC pavements, the groove shall be flushed with high pressure water or shot blasted to remove any PCC particles that may have become destabilized during the grooving process. If high pressure water is used, the pavement surface shall be allowed to dry for a minimum of 24 hours prior to the final cleaning of the groove and application of the pavement marking material.

Pavement Grooving. Grooving shall not cause ravels, aggregate fractures, spalling or disturbance of the joints to the underlying surface of the pavement. Grooves shall be cut into

the pavement prior to the application of the pavement marking material. Grooves shall be cut such that the width is 1 in. (25 mm) greater than the width of the pavement marking line as specified on the plans. Grooves for letters and symbols shall be cut in a square or rectangular shape so that the entire marking will fit within the limits of the grooved area. The position of the edge of the grooves shall be a minimum of 2 in. (50 mm) from the edge of all longitudinal joints. The depth of the groove shall not be less than the manufacturer's recommendations for the pavement marking material specified, but shall be installed to a minimum depth of 110 mils (2.79 mm) and a maximum depth of 200 mils (5.08 mm) for pavement marking tapes thermoplastic markings and a minimum depth of 40 mils (1.02 mm) and a maximum depth of 80 mils (2.03 mm) for liquid markings. The cutting head shall be operated at the appropriate speed in order to prevent undulation of the cutting head and grooving at an inconsistent depth.

At the start of grooving operations, a 50 ft (16.7 m) test section shall be installed and depth measurements shall be made at 10 ft (3.3 m) intervals within the test section. The individual depth measurements shall be within the allowable ranges according to this Article. If it is determined the test section has not been grooved at the appropriate depth or texture, adjustments shall be made to the cutting head and another 50 ft (16.7 m) test section shall be installed and checked. This process shall continue until the test section meets the requirements of this Article.

For new HMA pavements, grooves shall not be installed within 10 days of the placement of the final course of pavement.

Final Cleaning. Immediately prior to the application of the pavement marking material or primer sealer, the groove shall be cleaned with high-pressure air blast.

Method of Measurement. This work will be measured for payment in place, in feet (meter) for the groove width specified.

Grooving for letter, numbers and symbols will be measured in square feet (square meters).

Basis of Payment. This work will be paid for at the contract unit price per foot (meter) for GROOVING FOR RECESSED PAVEMENT MARKING of the groove width specified, and per square foot (square meter) for GROOVING FOR RECESSED PAVEMENT MARKING, LETTERS AND SYMBOLS.

The following shall only apply when preformed plastic pavement markings are to be recessed:

Add the following paragraph after the first paragraph of Article 780.07 of the Standard Specifications.

"The markings shall be capable of being applied in a grooved slot on new and existing portland cement concrete and HMA surfaces, by means of a pressure-sensitive, pre-coated adhesive, or liquid contact cement which shall be applied at the time of installation. A primer sealer shall be applied with a roller and shall cover and seal the entire bottom of the groove.

The primer sealer shall be recommended by the manufacturer of the pavement marking material and shall be compatible with the material being used. The Contractor shall install the markings in the groove as soon as possible after the primer sealer cures according to the manufacturer's recommendations. The markings placed in the groove shall be rolled and tamped into the groove with a roller or tamper cart cut to fit the groove and loaded with or weighing at least 200 lb (90kg). Vehicle tires shall not be used for tamping. The Contractor shall roll and tamp the material with a minimum of 6 passes to prevent easy removal or peeling."

80304

HOT-MIX ASPHALT - DENSITY TESTING OF LONGITUDINAL JOINTS (BDE)

Effective: January 1, 2010

Revised: August 1, 2018

Description. This work shall consist of testing the density of longitudinal joints as part of the quality control/quality assurance (QC/QA) of hot-mix asphalt (HMA). Work shall be according to Section 1030 of the Standard Specifications except as follows.

Quality Control/Quality Assurance (QC/QA). Delete the second and third sentence of the third paragraph of Article 1030.05(d)(3) of the Standard Specifications.

Add the following paragraphs to the end of Article 1030.05(d)(3) of the Standard Specifications:

“Longitudinal joint density testing shall be performed at each random density test location. Longitudinal joint testing shall be located at a distance equal to the lift thickness or a minimum of 4 in. (100 mm), from each pavement edge. (i.e. for a 5 in. (125 mm) lift the near edge of the density gauge or core barrel shall be within 5 in. (125 mm) from the edge of pavement.) Longitudinal joint density testing shall be performed using either a correlated nuclear gauge or cores.

- a. Confined Edge. Each confined edge density shall be represented by a one-minute nuclear density reading or a core density and shall be included in the average of density readings or core densities taken across the mat which represents the Individual Test.
- b. Unconfined Edge. Each unconfined edge joint density shall be represented by an average of three one-minute density readings or a single core density at the given density test location and shall meet the density requirements specified herein. The three one-minute readings shall be spaced 10 ft (3 m) apart longitudinally along the unconfined pavement edge and centered at the random density test location.

When a longitudinal joint sealant (LJS) is applied, longitudinal joint density testing will not be required on the joint(s) sealed.”

Revise the Density Control Limits table in Article 1030.05(d)(4) of the Standard Specifications to read:

“Mixture Composition	Parameter	Individual Test (includes confined edges)	Unconfined Edge Joint Density Minimum
IL-4.75	Ndesign = 50	93.0 – 97.4% ^{1/}	91.0%
IL-9.5	Ndesign = 90	92.0 – 96.0%	90.0%
IL-9.5,IL-9.5L	Ndesign < 90	92.5 – 97.4%	90.0%
IL-19.0	Ndesign = 90	93.0 – 96.0%	90.0%
IL-19.0, IL-19.0L	Ndesign < 90	93.0 ^{2/} – 97.4%	90.0%

SMA	Ndesign = 50 & 80	93.5 – 97.4%	91.0%”
-----	-------------------	--------------	--------

80246

HOT-MIX ASPHALT – LONGITUDINAL JOINT SEALANT (BDE)

Effective: August 1, 2018
Revised: January 1, 2019

Add the following to Article 406.02 of the Standard Specifications.

“(d) Longitudinal Joint Sealant (LJS)1032”

Add the following to Article 406.03 of the Standard Specifications.

- “(k) Longitudinal Joint Sealant (LJS) Pressure Distributor (Note 2)
- (l) Longitudinal Joint Sealant (LJS) Melter Kettle (Note 3)

Note 2. When a pressure distributor is used to apply the LJS, the distributor shall be equipped with a heating and recirculating system along with a functioning auger agitating system or vertical shaft mixer in the hauling tank to prevent localized overheating. The distributor shall be equipped with a guide or laser system to aid in proper placement of the LJS application.

Note 3. When a melter kettle is used to transport and apply the LJS, the melter kettle shall be an oil jacketed double-boiler with agitating and recirculating systems. Material from the kettle may be dispensed through a pressure feed wand with an applicator shoe or through a pressure feed wand into a hand-operated thermal push cart.”

Revise Article 406.06(g)(2) of the Standard Specifications to read:

“(2) Longitudinal Joints. Unless prohibited by stage construction, any HMA lift shall be complete before construction of the subsequent lift. The longitudinal joint in all lifts shall be at the centerline of the pavement if the roadway comprises two lanes in width, or at lane width if the roadway is more than two lanes in width.

When stage construction prohibits the total completion of a particular lift, the longitudinal joint in one lift shall be offset from the longitudinal joint in the preceding lift by not less than 3 in. (75 mm). The longitudinal joint in the surface course shall be at the centerline of the pavement if the roadway comprises two lanes in width, or at lane width if the roadway is more than two lanes in width.

A notched wedge longitudinal joint shall be used between successive passes of HMA binder course that has a difference in elevation of greater than 2 in. (50 mm) between lanes on pavement that is open to traffic.

The notched wedge longitudinal joint shall consist of a 1 to 1 1/2 in. (25 to 38 mm) vertical notch at the lane line, a 9 to 12 in. (230 to 300 mm) wide uniform taper sloped toward and extending into the open lane, and a second 1 to 1 1/2 in. (25 to 38 mm) vertical notch at the outside edge.

The notched wedge longitudinal joint shall be formed by the strike off device on the paver. The wedge shall then be compacted by the joint roller.

Tack coat shall be applied to the entire surface of the notched wedge joint immediately prior to placing the adjacent lift of binder. The material shall be uniformly applied at a rate of 0.05 to 0.1 gal/sq yd (0.2 to 0.5 L/sq m).

When the use of LJS is specified, it shall be applied for the lift(s) of paving as shown on the plans. The surface to which the LJS is applied shall be dry and cleaned of all dust, debris, and any substances that will prevent the LJS from adhering. Cleaning shall be accomplished by means of a sweeper/vacuum truck, power broom, air compressor or by hand. The LJS may be placed before or after the tack or prime coat. When placed after the tack or prime coat, the tack or prime shall be fully cured prior to placement of the LJS.

The LJS shall be centered ± 2 in. (± 50 mm) under the joint of the next HMA lift to be constructed.

The width and minimum application rate of LJS shall be according to the following table.

LJS Application Table		
Overlay Thickness in. (mm)	LJS Width in. (mm)	Application Rate ^{1/} lb/ft (kg/m)
HMA Mixtures		
3/4 (19)	18 (450)	0.88 (1.31)
1 (25)	18 (450)	1.15 (1.71)
1 1/4 (32)	18 (450)	1.31 (1.95)
1 1/2 (38)	18 (450)	1.47 (2.19)
1 3/4 (44)	18 (450)	1.63 (2.43)
2 (50)	18 (450)	1.80 (2.68)
2 1/4 (60)	18 (450)	1.96 (2.92)
2 1/2 (63)	18 (450)	2.12 (3.16)
2 3/4 (70)	18 (450)	2.29 (3.41)
3 (75)	18 (450)	2.45 (3.65)
3 1/4 (83)	18 (450)	2.61 (3.89)
3 1/2 (90)	18 (450)	2.78 (4.14)
3 3/4 (95)	18 (450)	2.94 (4.38)
4 (100)	18 (450)	3.10 (4.62)
SMA Mixtures		
1 1/2 (38)	18 (450)	1.26 (1.88)
1 3/4 (44)	18 (450)	1.38 (2.06)

2 (50)	18 (450)	1.51 (2.25)
--------	----------	-------------

- 1/ The application rate has a surface demand for liquid included within it. The thickness of the LJS may taper from the center of the application to a lesser thickness on the edge of the application, provided the correct width and application rate are maintained.

The Contractor shall furnish to the Engineer a bill of lading for each tanker supplying material to the project. The application rate of LJS shall be verified within the first 1000 ft (300 m) of the day's scheduled application length and every 12,000 ft (3600 m) the remainder of the day. For projects less than 3000 ft (900 m), the rate shall be verified once. A suitable paper or pan shall be placed at a random location in the path of the LJS. After application of the LJS, the paper or pan shall be picked up, weighed, and the application rate calculated. The tolerance between the application rate shown in the LJS Application Table and the calculated rate shall be ± 15 percent. The Contractor shall replace the LJS in the area where the sample was taken.

A 1 qt (1 L) sample shall be taken from the pressure distributor or melting kettle at the jobsite once for each contract and sent to the Central Bureau of Materials.

The LJS shall be applied in a single pass with a pressure distributor, melter kettle, or hand applied from a roll for HMA lifts up to 2 in. (50 mm) in thickness. The LJS shall be applied in two passes for HMA lifts between 2 and 4 in. (50 and 100 mm) in thickness. At the time of installation, the pavement surface temperature and the ambient temperature shall be a minimum of 40 °F (4 °C) and rising.

The LJS shall be applied at a width of not less than or greater than 1 1/2 in. (38 mm) of the width specified. If the LJS flows more than 2 in. (50 mm) from the initial placement width, LJS placement shall stop and remedial action shall be taken.

When starting another run of LJS placement, suitable release paper shall be placed over the previous application of LJS to prevent doubling up of thickness of LJS.

The LJS shall be suitable for construction traffic to drive on without pickup or tracking of the LJS within 30 minutes of placement. If pickup or tracking occurs, LJS placement shall stop and damaged areas shall be repaired.

Prior to paving, the Contractor shall ensure the paver end plate and grade control device is adequately raised above the finished height of the LJS.

The LJS shall not flush to the final surface of the HMA pavement."

Add the following paragraph after the second paragraph of Article 406.13(b) of the Standard Specifications.

“Application of longitudinal joint sealant (LJS) will be measured for payment in place in feet (meters).”

Add the following paragraph after the first paragraph of Article 406.14 of the Standard Specifications.

“Longitudinal joint sealant will be paid for at the contract unit price per foot (meter) for LONGITUDINAL JOINT SEALANT.”

Add the following to Section 1032 of the Standard Specifications.

“1032.12 Longitudinal Joint Sealant (LJS). Longitudinal joint sealant (LJS) will be accepted according to the current Bureau of Materials and Physical Research Policy Memorandum, “Performance Graded Asphalt Binder Acceptance Procedure” with the following exceptions: Article 3.1.9 and 3.4.1.4 of the policy memorandum will be excluded. The bituminous material used for the LJS shall be according to the following table. Elastomers shall be added to a base asphalt and shall be either a styrene-butadiene diblock or triblock copolymer without oil extension, or a styrene-butadiene rubber. Air blown asphalt, acid modification, or other modifiers will not be allowed. LJS in the form of pre-formed rollout banding may also be used.

Test	Test Requirement	Test Method
Dynamic shear @ 88°C (unaged), G*/sin δ, kPa	1.00 min.	AASHTO T 315
Creep stiffness @ -18°C (unaged), Stiffness (S), MPa m-value	300 max. 0.300 min.	AASHTO T 313
Ash, %	1.0 – 4.0	AASHTO T 111
Elastic Recovery, 100 mm elongation, cut immediately, 25°C, %	70 min.	ASTM D 6084 (Procedure A)
Separation of Polymer, Difference in °C of the softening point (ring and ball)	3 max.	ITP Separation of Polymer from Asphalt Binder”

80398

HOT-MIX ASPHALT – OSCILLATORY ROLLER (BDE)

Effective: August 1, 2018
 Revised: November 1, 2018

Add the following to Article 406.03 of the Standard Specifications:

“(j) Oscillatory Roller 1101.01”

Revise Table 1 and Note 3/ of Table 1 in Article 406.07(a) of the Standard Specifications to read:

“TABLE 1 - MINIMUM ROLLER REQUIREMENTS FOR HMA				
	Breakdown Roller (one of the following)	Intermediate Roller	Final Roller (one or more of the following)	Density Requirement
Level Binder: (When the density requirements of Article 406.05(c) do not apply.)	P ^{3/}	--	V _S , P ^{3/} , T _B , T _F , 3W, O _T	To the satisfaction of the Engineer.
Binder and Surface ^{1/} Level Binder ^{1/} : (When the density requirements of Article 406.05(c) apply.)	V _D , P ^{3/} , T _B , 3W, O _T , O _B	P ^{3/} , O _T , O _B	V _S , T _B , T _F , O _T	As specified in Articles: 1030.05(d)(3), (d)(4), and (d)(7).
IL-4.75 and SMA ^{4/5/}	T _B , 3W, O _T	--	T _F , 3W, O _T	
Bridge Decks ^{2/}	T _B	--	T _F	As specified in Articles 582.05 and 582.06.

3/ A vibratory roller (V_D) or oscillatory roller (O_T or O_B) may be used in lieu of the pneumatic-tired roller on mixtures containing polymer modified asphalt binder.”

Add the following to EQUIPMENT DEFINITION in Article 406.07(a) contained in the Errata of the Supplemental Specifications:

“O_T - Oscillatory roller, tangential impact mode. Maximum speed is 3.0 mph (4.8 km/h) or 264 ft/min (80 m/min).

O_B - Oscillatory roller, tangential and vertical impact mode, operated at a speed to produce not less than 10 vertical impacts/ft (30 impacts/m).”

Add the following to Article 1101.01 of the Standard Specifications:

“(h) Oscillatory Roller. The oscillatory roller shall be self-propelled and provide a smooth operation when starting, stopping, or reversing directions. The oscillatory roller shall be able to operate in a mode that will provide tangential impact force with or without vertical impact force by using at least one drum. The oscillatory roller shall be equipped with water tanks and sprinkling devices, or other approved methods, which shall be used to wet the drums to prevent material pickup. The drum(s) amplitude and frequency of the tangential and vertical impact force shall be approximately the same in each direction and meet the following requirements:

- (1) The minimum diameter of the drum(s) shall be 42 in. (1070 mm)48 in. (1200 mm);
- (2) The minimum length of the drum(s) shall be 57 in. (1480 mm)66 in. (1650 mm);
- (3) The minimum unit static force on the drum(s) shall be 125 lb/in. (22 N/m); and
- (4) The minimum force on the oscillatory drum shall be 18,000 lb (80 kN).”; and
- (5) Self-adjusting eccentrics, and reversible eccentrics on non-driven drum(s).”

80399

LIGHTS ON BARRICADES (BDE)

Effective: January 1, 2018

Revise Article 701.16 of the Standard Specifications to read:

“701.16 Lights. Lights shall be used on devices as required in the plans, the traffic control plan, and the following table.

Circumstance	Lights Required
Daylight operations	None
First two warning signs on each approach to the work involving a nighttime lane closure and “ROUGH GROOVED SURFACE” (W8-I107) signs	Flashing mono-directional lights
Devices delineating isolated obstacles, excavations, or hazards at night (Does not apply to patching)	Flashing bi-directional lights
Devices delineating obstacles, excavations, or hazards exceeding 100 ft (30 m) in length at night (Does not apply to widening)	Steady burn bi-directional lights
Channelizing devices for nighttime lane closures on two-lane roads	None
Channelizing devices for nighttime lane closures on multi-lane roads	None
Channelizing devices for nighttime lane closures on multi-lane roads separating opposing directions of traffic	None
Channelizing devices for nighttime along lane shifts on multilane roads	Steady burn mono-directional lights
Channelizing devices for night time along lane shifts on two lane roads	Steady burn bi-directional lights
Devices in nighttime lane closure tapers on Standards 701316 and 701321	Steady burn bi-directional lights
Devices in nighttime lane closure tapers	Steady burn mono-directional lights
Devices delineating a widening trench	None
Devices delineating patches at night on roadways with an ADT less than 25,000	None
Devices delineating patches at night on roadways with an ADT of 25,000 or more	None

Batteries for the lights shall be replaced on a group basis at such times as may be specified by the Engineer.”

Delete the fourth sentence of the first paragraph of Article 701.17(c)(2) of the Standard Specifications.

Revise the first paragraph of Article 603.07 of the Standard Specifications to read:

“603.07 Protection Under Traffic. After the casting has been adjusted and Class SI concrete has been placed, the work shall be protected by a barricade for at least 72 hours.”

80392

MANHOLES, VALVE VAULTS, AND FLAT SLAB TOPS (BDE)

Effective: January 1, 2018
 Revised: March 1, 2019

Description. In addition to those manufactured according to the current standards included in this contract, manholes, valve vaults, and flat slab tops manufactured prior to March 1, 2019, according to the previous Highway Standards listed below will be accepted on this contract:

Product	Previous Standards		
Precast Manhole Type A, 4' (1.22 m) Diameter	602401-05	602401-04	602401-03
Precast Manhole Type A, 5' (1.52 m) Diameter	602402-01	602402	602401-03
Precast Manhole Type A, 6' (1.83 m) Diameter	602406-09	602406-08	602406-07
Precast Manhole Type A, 7' (2.13 m) Diameter	602411-07	602411-06	602411-05
Precast Manhole Type A, 8' (2.44 m) Diameter	602416-07	602416-06	602416-05
Precast Manhole Type A, 9' (2.74 m) Diameter	602421-07	602421-06	602421-05
Precast Manhole Type A, 10' (3.05 m) Diameter	602426-01	602426	
Precast Valve Vault Type A, 4' (1.22 m) Diameter	602501-04	602501-03	602501-02
Precast Valve Vault Type A, 5' (1.52 m) Diameter	602506-01	602506	602501-02
Precast Reinforced Concrete Flat Slab Top	602601-05	602601-04	

The following revisions to the Standard Specifications shall apply to manholes, valve vaults, and flat slab tops manufactured according to the current standards included in this contract:

Revise Article 602.02(g) of the Standard Specifications to read:

“(g) Structural Steel (Note 4) 1006.04

Note 4. All components of the manhole joint splice shall be galvanized according to the requirements of AASHTO M 111 or M 232 as applicable.”

Add the following to Article 602.02 of the Standard Specifications:

“(s) Anchor Bolts and Rods (Note 5) 1006.09

Note 5. The threaded rods for the manhole joint splice shall be according to the requirements of ASTM F 1554, Grade 55, (Grade 380).”

Revise the second paragraph of Article 1042.10 of the Standard Specifications to read:

“Catch basin Types A, B, C, and D; Manhole Type A; Inlet Types A and B; Drainage Structures Types 1, 2, 3, 4, 5, and 6; Valve Vault Type A; and reinforced concrete flat slab top (Highway Standard 602601) shall be manufactured according to AASHTO M 199 (M 199M), except the minimum wall thickness shall be as shown on the plans. Additionally, catch basins, inlets, and drainage structures shall have a minimum concrete compressive strength of 4500 psi

(31,000 kPa) at 28 days and manholes, valve vaults, and reinforced concrete flat slab tops shall have a minimum concrete compressive strength of 5000 psi (34,500 kPa) at 28 days.”

80393

MAST ARM ASSEMBLY AND POLE (BDE)

Effective: August 1, 2018

Revise the first sentence of Article 1077.03(b) of the Standard Specifications to read:

“Anchor rods shall be according to Article 1006.09, Grade 105, and shall be threaded a minimum of 7 1/2 in. (185 mm) at one end and threaded a minimum of 2 in. (50 mm) with matching hex head nut at the other end.”

80400

PAVEMENT MARKING BLACKOUT TAPE (BDE)

Effective: November 1, 2014

Revised: April 1, 2016

Revise the fourth paragraph of Article 701.04 of the Standard Specifications to read:

“The traffic control shall remain in place only as long as needed and shall be removed when directed by the Engineer. Signs that do not apply to current conditions shall be removed, covered, or turned from the view of motorists. All existing pavement markings which conflict with the revised traffic pattern shall be removed according to Section 783 or when specified, temporarily covered with pavement marking blackout tape. The width of blackout tape shall be at least 1 in. (25 mm) wider than the width of the pavement marking being covered. The removing or covering of existing markings shall be scheduled immediately to facilitate the revised traffic pattern. If darkness or inclement weather prohibits the removal or covering operations, such operations shall be resumed the next morning or when weather permits.”

Revise Article 701.19(f) of the Standard Specifications to read:

“(f) Removal of existing pavement markings and raised reflective pavement markers will be measured for payment according to Article 783.05. Temporary covering of existing pavement markings with blackout tape will be measured for payment in feet (meters) in place. Removal of blackout tape will be measured for payment in square feet (square meters).”

Revise Article 701.20(j) of the Standard Specifications to read:

“(j) Removal of existing pavement markings and raised reflective pavement markers will be paid for according to Article 783.06. Temporary covering of existing pavement markings with blackout tape will be paid for at the contract unit price per foot for PAVEMENT MARKING BLACKOUT TAPE, of the line width specified.” Removal of blackout tape will be paid for as short term pavement marking removal according to Article 703.07.”

Revise the first two paragraphs of Article 1095.06 of the Standard Specifications to read:

“**1095.06 Pavement Marking Tape.** White or yellow marking tape shall consist of glass spheres of high optical quality embedded into a binder on a suitable backing that is precoated with a pressure sensitive adhesive. The spheres shall be of uniform gradation and distributed evenly over the surface of the tape. Blackout marking tape shall be a Type III tape consisting of a matte black, non-reflective, patterned surface that is precoated with a pressure sensitive adhesive. The surface of the blackout pavement marking tape shall provide a minimum skid resistance value of 45 BPN when tested according to ASTM E 303-74.

The material shall be white, yellow, or matte black as specified. White and yellow colors shall conform closely to Federal color tolerances for pavement marking paint.”

Revise the second table of Article 1095.06 to read:

"Test	Type I		Type III		
	White	Yellow	White	Yellow	Blackout
Initial Thickness, mils (mm)	20 (0.51)	20 (0.51)	20 (0.51)	20 (0.51)	65 (1.65) ^{1/} 10 (0.25) ^{2/}
Durability (cycles)	5,000	5,000	1,500	1,500	1,500

Notes:

- 1/ Measured at the thickest point of the patterned surface.
- 2/ Measured at the thinnest point of the patterned surface."

80349

PAVEMENT MARKING REMOVAL (BDE)

Effective: July 1, 2016

Revise Article 783.02 of the Standard Specifications to read:

“783.02 Equipment. Equipment shall be according to the following.

Item	Article/Section
(a) Grinders (Note 1)	
(b) Water Blaster with Vacuum Recovery	1101.12

Note 1. Grinding equipment shall be approved by the Engineer.”

Revise the first paragraph of Article 783.03 of the Standard Specifications to read:

“783.03 Removal of Conflicting Markings. Existing pavement markings that conflict with revised traffic patterns shall be removed. If darkness or inclement weather prohibits the removal operations, such operations shall be resumed the next morning or when weather permits. In the event of removal equipment failure, such equipment shall be repaired, replaced, or leased so removal operations can be resumed within 24 hours.”

Revise the first and second sentences of the first paragraph of Article 783.03(a) of the Standard Specifications to read:

“The existing pavement markings shall be removed by the method specified and in a manner that does not materially damage the surface or texture of the pavement or surfacing. Small particles of tightly adhering existing markings may remain in place, if in the opinion of the Engineer, complete removal of the small particles will result in pavement surface damage.”

Revise the first paragraph of Article 783.04 of the Standard Specifications to read:

“783.04 Cleaning. The roadway surface shall be cleaned of debris or any other deleterious material by the use of compressed air or water blast.”

Revise the first paragraph of Article 783.06 of the Standard Specifications to read:

“783.06 Basis of Payment. This work will be paid for at the contract unit price per each for RAISED REFLECTIVE PAVEMENT MARKER REMOVAL, or at the contract unit price per square foot (square meter) for PAVEMENT MARKING REMOVAL – GRINDING and/or PAVEMENT MARKING REMOVAL – WATER BLASTING.”

Delete Article 1101.13 from the Standard Specifications.

80371

PAYMENTS TO SUBCONTRACTORS (BDE)

Effective: November 2, 2017

Add the following to the end of the fourth paragraph of Article 109.11 of the Standard Specifications:

“If reasonable cause is asserted, written notice shall be provided to the applicable subcontractor and/or material supplier and the Engineer within five days of the Contractor receiving payment. The written notice shall identify the contract number, the subcontract or material purchase agreement, a detailed reason for refusal, the value of payment being withheld, and the specific remedial actions required of the subcontractor and/or material supplier so that payment can be made.”

80390

PORTLAND CEMENT CONCRETE (BDE)

Effective: November 1, 2017

Revise the Air Content % of Class PP Concrete in Table 1 Classes of Concrete and Mix Design Criteria in Article 1020.04 of the Standard Specifications to read:

"TABLE 1. CLASSES OF CONCRETE AND MIX DESIGN CRITERIA		
Class of Conc.	Use	Air Content %
PP	Pavement Patching Bridge Deck Patching (10)	
	PP-1	4.0 - 8.0"
	PP-2	
	PP-3	
	PP-4	
	PP-5	

Revise Note (4) at the end of Table 1 Classes of Concrete and Mix Design Criteria in Article 1020.04 of the Standard Specifications to read:

“(4) For all classes of concrete, the maximum slump may be increased to 7 in (175 mm) when a high range water-reducing admixture is used. For Class SC, the maximum slump may be increased to 8 in. (200 mm). For Class PS, the maximum slump may be increased to 8 1/2 in. (215 mm) if the high range water-reducing admixture is the polycarboxylate type.”

80389

PROGRESS PAYMENTS (BDE)

Effective: November 2, 2013

Revise Article 109.07(a) of the Standard Specifications to read:

“(a) Progress Payments. At least once each month, the Engineer will make a written estimate of the quantity of work performed in accordance with the contract, and the value thereof at the contract unit prices. The amount of the estimate approved as due for payment will be vouchered by the Department and presented to the State Comptroller for payment. No amount less than \$1000.00 will be approved for payment other than the final payment.

Progress payments may be reduced by liens filed pursuant to Section 23(c) of the Mechanics' Lien Act, 770 ILCS 60/23(c).

If a Contractor or subcontractor has defaulted on a loan issued under the Department's Disadvantaged Business Revolving Loan Program (20 ILCS 2705/2705-610), progress payments may be reduced pursuant to the terms of that loan agreement. In such cases, the amount of the estimate related to the work performed by the Contractor or subcontractor, in default of the loan agreement, will be offset, in whole or in part, and vouchered by the Department to the Working Capital Revolving Fund or designated escrow account. Payment for the work shall be considered as issued and received by the Contractor or subcontractor on the date of the offset voucher. Further, the amount of the offset voucher shall be a credit against the Department's obligation to pay the Contractor, the Contractor's obligation to pay the subcontractor, and the Contractor's or subcontractor's total loan indebtedness to the Department. The offset shall continue until such time as the entire loan indebtedness is satisfied. The Department will notify the Contractor and Fund Control Agent in a timely manner of such offset. The Contractor or subcontractor shall not be entitled to additional payment in consideration of the offset.

The failure to perform any requirement, obligation, or term of the contract by the Contractor shall be reason for withholding any progress payments until the Department determines that compliance has been achieved.”

80328

RAILROAD PROTECTIVE LIABILITY INSURANCE (5 AND 10) (BDE)

Effective: January 1, 2006

Description. Railroad Protective Liability and Property Damage Liability Insurance shall be carried according to Article 107.11 of the Standard Specifications, except the limits shall be a minimum of \$5,000,000 combined single limit per occurrence for bodily injury liability and property damage liability with an aggregate limit of \$10,000,000 over the life of the policy. A separate policy is required for each railroad unless otherwise noted.

NAMED INSURED & ADDRESS	NUMBER & SPEED OF PASSENGER TRAINS	NUMBER & SPEED OF FREIGHT TRAINS
Wisconsin Central Limited 17641 South Ashland Avenue Homewood, IL 60430	22 Trains/Day Min Psgr Speed: 5 MPH Max Psgr Speed: 50 MPH	20 Trains/Day Min Freight Speed: 5 MPH Max Freight Speed: 50 MPH
DOT/AAR No.: 689692X RR Division: Chicago Terminal	RR Mile Post: 33.21 RR Sub-Division: Waukesha	
For Freight/Passenger Information Contact: Paul Chojenski For Insurance Information Contact: Paul Chojenski		Phone: (708) 332-3557 Phone: (708) 332-3557

DOT/AAR No.:	RR Mile Post:	
RR Division:	RR Sub-Division:	
For Freight/Passenger Information Contact:		Phone:
For Insurance Information Contact:		Phone:

Approval of Insurance. The original and one certified copy of each required policy shall be submitted to the following address for approval:

Illinois Department of Transportation
Bureau of Design and Environment
2300 South Dirksen Parkway, Room 326
Springfield, Illinois 62764

The Contractor will be advised when the Department has received approval of the insurance from the railroad(s). Before any work begins on railroad right-of-way, the Contractor shall submit to the Engineer evidence that the required insurance has been approved by the railroad(s). The Contractor shall also provide the Engineer with the expiration date of each required policy.

Basis of Payment. Providing Railroad Protective Liability and Property Damage Liability Insurance will be paid for at the contract unit price per Lump Sum for RAILROAD PROTECTIVE LIABILITY INSURANCE.

80157

SUBCONTRACTOR AND DBE PAYMENT REPORTING (BDE)

Effective: April 2, 2018

Add the following to Section 109 of the Standard Specifications.

“109.14 Subcontractor and Disadvantaged Business Enterprise Payment Reporting.
The Contractor shall report all payments made to the following parties:

- (a) first tier subcontractors;
- (b) lower tier subcontractors affecting disadvantaged business enterprise (DBE) goal credit;
- (c) material suppliers or trucking firms that are part of the Contractor’s submitted DBE utilization plan.

The report shall be made through the Department’s on-line subcontractor payment reporting system within 21 days of making the payment.”

80397

SUBCONTRACTOR MOBILIZATION PAYMENTS (BDE)

Effective: November 2, 2017

Revised: April 1, 2019

Replace the second paragraph of Article 109.12 of the Standard Specifications with the following:

“This mobilization payment shall be made at least seven days prior to the subcontractor starting work. The amount paid shall be at the following percentage of the amount of the subcontract reported on form BC 260A submitted for the approval of the subcontractor’s work.

Value of Subcontract Reported on Form BC 260A	Mobilization Percentage
Less than \$10,000	25%
\$10,000 to less than \$20,000	20%
\$20,000 to less than \$40,000	18%
\$40,000 to less than \$60,000	16%
\$60,000 to less than \$80,000	14%
\$80,000 to less than \$100,000	12%
\$100,000 to less than \$250,000	10%
\$250,000 to less than \$500,000	9%
\$500,000 to \$750,000	8%
Over \$750,000	7%”

80391

TEMPORARY PAVEMENT MARKING (BDE)

Effective: April 1, 2012

Revised: April 1, 2017

Revise Article 703.02 of the Standard Specifications to read:

“703.02 Materials. Materials shall be according to the following.

- (a) Pavement Marking Tape, Type I and Type III 1095.06
- (b) Paint Pavement Markings 1095.02
- (c) Pavement Marking Tape, Type IV 1095.11”

Revise the second paragraph of Article 703.05 of the Standard Specifications to read:

“Type I marking tape or paint shall be used at the option of the Contractor, except paint shall not be applied to the final wearing surface unless authorized by the Engineer for late season applications where tape adhesion would be a problem. Type III or Type IV marking tape shall be used on the final wearing surface when the temporary pavement marking will conflict with the permanent pavement marking such as on tapers, crossovers and lane shifts.”

Revise Article 703.07 of the Standard Specifications to read:

“703.07 Basis of Payment. This work will be paid for as follows.

- a) Short Term Pavement Marking. Short term pavement marking will be paid for at the contract unit price per foot (meter) for SHORT TERM PAVEMENT MARKING. Removal of short term pavement markings will be paid for at the contract unit price per square foot (square meter) for SHORT TERM PAVEMENT MARKING REMOVAL.
- b) Temporary Pavement Marking. Where the Contractor has the option of material type, temporary pavement marking will be paid for at the contract unit price per foot (meter) for TEMPORARY PAVEMENT MARKING of the line width specified, and at the contract unit price per square foot (square meter) for TEMPORARY PAVEMENT MARKING LETTERS AND SYMBOLS.

Where the Department specifies the use of pavement marking tape, the Type III or Type IV temporary pavement marking will be paid for at the contract unit price per foot (meter) for PAVEMENT MARKING TAPE, TYPE III or PAVEMENT MARKING TAPE, TYPE IV of the line width specified and at the contract unit price per square feet (square meter) for PAVEMENT MARKING TAPE, TYPE III - LETTERS AND SYMBOLS or PAVEMENT MARKING TAPE, TYPE IV – LETTERS AND SYMBOLS.

Removal of temporary pavement markings will be paid for at the contract unit price per square foot (square meter) for TEMPORARY PAVEMENT MARKING REMOVAL.

When temporary pavement marking is shown on the Standard, the cost of the temporary pavement marking and its removal will be included in the cost of the Standard.”

Add the following to Section 1095 of the Standard Specifications:

“1095.11 Pavement Marking Tape, Type IV. The temporary, preformed, patterned markings shall consist of a white or yellow tape with wet retroreflective media incorporated to provide immediate and continuing retroreflection during both wet and dry conditions. The tape shall be manufactured without the use of heavy metals including lead chromate pigments or other similar, lead-containing chemicals.

The white and yellow Type IV marking tape shall meet the Type III requirements of Article 1095.06 and the following.

- (a) Composition. The retroreflective pliant polymer pavement markings shall consist of a mixture of high-quality polymeric materials, pigments and glass beads distributed throughout its base cross-sectional area, with a layer of wet retroreflective media bonded to a durable polyurethane topcoat surface. The patterned surface shall have approximately 40% ± 10% of the surface area raised and presenting a near vertical face to traffic from any direction. The channels between the raised areas shall be substantially free of exposed beads or particles.
- (b) Retroreflectance. The white and yellow markings shall meet the following for initial dry and wet retroreflectance.
 - (1) Dry Retroreflectance. Dry retroreflectance shall be measured under dry conditions according to ASTM D 4061 and meet the values described in Article 1095.06 for Type III tape.
 - (2) Wet Retroreflectance. Wet retroreflectance shall be measured under wet conditions according to ASTM E 2177 and meet the values shown in the following table.

Wet Retroreflectance, Initial R_L

Color	R _L 1.05/88.76
White	300
Yellow	200

- (c) Color. The material shall meet the following requirements for daylight reflectance and color, when tested, using a color spectrophotometer with 45 degrees circumferential/zero degree geometry, illuminant D65, and a two degree observer angle. The color instrument shall measure the visible spectrum from 380 to 720 nm with a wavelength measurement interval and spectral bandpass of 10 nm.

Color	Daylight Reflectance %Y
White	65 minimum
*Yellow	36-59

*Shall match Federal 595 Color No. 33538 and the chromaticity limits as follows.

x	0.490	0.475	0.485	0.530
y	0.470	0.438	0.425	0.456

- (d) Skid Resistance. The surface of the markings shall provide an average minimum skid resistance of 50 BPN when tested according to ASTM E 303.
- (e) Sampling, Testing, Acceptance, and Certification. Prior to approval and use of the wet reflective, temporary, removable pavement marking tape, the manufacturer shall submit a notarized certification from an independent laboratory, together with the results of all tests, stating that the material meets the requirements as set forth herein. The certification test report shall state the lot tested, manufacturer's name, and date of manufacture.

After approval by the Department, samples and certification by the manufacturer shall be submitted for each batch used. The manufacturer shall submit a certification stating that the material meets the requirements as set forth herein and is essentially identical to the material sent for qualification. The certification shall state the lot tested, manufacturer's name, and date of manufacture.

All costs of testing (other than tests conducted by the Department) shall be borne by the manufacturer."

80298

TRAFFIC CONTROL DEVICES - CONES (BDE)

Effective: January 1, 2019

Revise Article 701.15(a) of the Standard Specifications to read:

“(a) Cones. Cones are used to channelize traffic. Cones used to channelize traffic at night shall be reflectorized; however, cones shall not be used in nighttime lane closure tapers or nighttime lane shifts.”

Revise Article 1106.02(b) of the Standard Specifications to read:

“(b) Cones. Cones shall be predominantly orange. Cones used at night that are 28 to 36 in. (700 to 900 mm) in height shall have two white circumferential stripes. If non-reflective spaces are left between the stripes, the spaces shall be no more than 2 in. (50mm) in width. Cones used at night that are taller than 36 in. (900 mm) shall have a minimum of two white and two fluorescent orange alternating, circumferential stripes with the top stripe being fluorescent orange. If non-reflective spaces are left between the stripes, the spaces shall be no more than 3 in. (75 mm) in width.

The minimum weights for the various cone heights shall be 4 lb for 18 in. (2 kg for 450 mm), 7 lb for 28 in. (3 kg for 700 mm), and 10 lb for 36 in. (5 kg for 900 mm) with a minimum of 60 percent of the total weight in the base. Cones taller than 36 in. shall be weighted per the manufacturer’s specifications such that they are not moved by wind or passing traffic.”

80409

WARM MIX ASPHALT (BDE)

Effective: January 1, 2012

Revised: April 1, 2016

Description. This work shall consist of designing, producing and constructing Warm Mix Asphalt (WMA) in lieu of Hot Mix Asphalt (HMA) at the Contractor's option. Work shall be according to Sections 406, 407, 408, 1030, and 1102 of the Standard Specifications, except as modified herein. In addition, any references to HMA in the Standard Specifications, or the special provisions shall be construed to include WMA.

WMA is an asphalt mixture which can be produced at temperatures lower than allowed for HMA utilizing approved WMA technologies. WMA technologies are defined as the use of additives or processes which allow a reduction in the temperatures at which HMA mixes are produced and placed. WMA is produced by the use of additives, a water foaming process, or combination of both. Additives include minerals, chemicals or organics incorporated into the asphalt binder stream in a dedicated delivery system. The process of foaming injects water into the asphalt binder stream, just prior to incorporation of the asphalt binder with the aggregate.

Approved WMA technologies may also be used in HMA provided all the requirements specified herein, with the exception of temperature, are met. However, asphalt mixtures produced at temperatures in excess of 275 °F (135 °C) will not be considered WMA when determining the grade reduction of the virgin asphalt binder grade.

Equipment.

Revise the first paragraph of Article 1102.01 of the Standard Specifications to read:

“1102.01 Hot-Mix Asphalt Plant. The hot-mix asphalt (HMA) plant shall be the batch-type, continuous-type, or dryer drum plant. The plants shall be evaluated for prequalification rating and approval to produce HMA according to the current Bureau of Materials and Physical Research Policy Memorandum, “Approval of Hot-Mix Asphalt Plants and Equipment”. Once approved, the Contractor shall notify the Bureau of Materials and Physical Research to obtain approval of all plant modifications. The plants shall not be used to produce mixtures concurrently for more than one project or for private work unless permission is granted in writing by the Engineer. The plant units shall be so designed, coordinated and operated that they will function properly and produce HMA having uniform temperatures and compositions within the tolerances specified. The plant units shall meet the following requirements.”

Add the following to Article 1102.01(a) of the Standard Specifications.

“(11) Equipment for Warm Mix Technologies.

- a. Foaming. Metering equipment for foamed asphalt shall have an accuracy of ± 2 percent of the actual water metered. The foaming control system shall be electronically interfaced with the asphalt binder meter.

- b. Additives. Additives shall be introduced into the plant according to the supplier's recommendations and shall be approved by the Engineer. The system for introducing the WMA additive shall be interlocked with the aggregate feed or weigh system to maintain correct proportions for all rates of production and batch sizes."

Mix Design Verification.

Add the following to Article 1030.04 of the Standard Specifications.

"(e) Warm Mix Technologies.

- (1) Foaming. WMA mix design verification will not be required when foaming technology is used alone (without WMA additives). However, the foaming technology shall only be used on HMA designs previously approved by the Department.
- (2) Additives. WMA mix designs utilizing additives shall be submitted to the Engineer for mix design verification."

Construction Requirements.

Revise the second paragraph of Article 406.06(b)(1) of the Standard Specifications to read:

"The HMA shall be delivered at a temperature of 250 to 350 °F (120 to 175 °C).
WMA shall be delivered at a minimum temperature of 215 °F (102 °C)."

Basis of Payment.

This work will be paid at the contract unit price bid for the HMA pay items involved. Anti-strip will not be paid for separately, but shall be considered as included in the cost of the work.

80288

WEEKLY DBE TRUCKING REPORTS (BDE)

Effective: June 2, 2012

| Revised: April 2, 2015

| The Contractor shall submit a weekly report of Disadvantaged Business Enterprise (DBE) trucks hired by the Contractor or subcontractors (i.e. not owned by the Contractor or subcontractors) that are used for DBE goal credit.

| The report shall be submitted to the Engineer on Department form "SBE 723" within ten business days following the reporting period. The reporting period shall be Monday through Sunday for each week reportable trucking activities occur.

Any costs associated with providing weekly DBE trucking reports shall be considered as included in the contract unit prices bid for the various items of work involved and no additional compensation will be allowed.

80302

WORKING DAYS (BDE)

Effective: January 1, 2002

The Contractor shall complete the work within 135 working days.

80071

PIPE UNDERDRAINS FOR STRUCTURES

Effective: May 17, 2000

Revised: January 22, 2010

Description. This work shall consist of furnishing and installing a pipe underdrain system as shown on the plans, as specified herein, and as directed by the Engineer.

Materials. Materials shall meet the requirements as set forth below:

The perforated pipe underdrain shall be according to Article 601.02 of the Standard Specifications. Outlet pipes or pipes connecting to a separate storm sewer system shall not be perforated.

The drainage aggregate shall be a combination of one or more of the following gradations, FA1, FA2, CA5, CA7, CA8, CA11, or CA13 thru 16, according to Sections 1003 and 1004 of the Standard Specifications.

The fabric surrounding the drainage aggregate shall be Geotechnical Fabric for French Drains according to Article 1080.05 of the Standard Specifications.

Construction Requirements. All work shall be according to the applicable requirements of Section 601 of the Standard Specifications except as modified below.

The pipe underdrains shall consist of a perforated pipe drain situated at the bottom of an area of drainage aggregate wrapped completely in geotechnical fabric and shall be installed to the lines and gradients as shown on the plans.

Method of Measurement. Pipe Underdrains for Structures shall be measured for payment in feet (meters), in place. Measurement shall be along the centerline of the pipe underdrains. All connectors, outlet pipes, elbows, and all other miscellaneous items shall be included in the measurement. Concrete headwalls shall be included in the cost of Pipe Underdrains for Structures, but shall not be included in the measurement for payment.

Basis of Payment. This work will be paid for at the contract unit price per foot (meter) for PIPE UNDERDRAINS FOR STRUCTURES of the diameter specified. Furnishing and installation of the drainage aggregate, geotechnical fabric, forming holes in structural elements and any excavation required, will not be paid for separately, but shall be included in the cost of the pipe underdrains for structures.

**REQUIRED CONTRACT PROVISIONS
FEDERAL-AID CONSTRUCTION CONTRACTS**

- I. General
- II. Nondiscrimination
- III. Nonsegregated Facilities
- IV. Davis-Bacon and Related Act Provisions
- V. Contract Work Hours and Safety Standards Act Provisions
- VI. Subletting or Assigning the Contract
- VII. Safety: Accident Prevention
- VIII. False Statements Concerning Highway Projects
- IX. Implementation of Clean Air Act and Federal Water Pollution Control Act
- X. Compliance with Governmentwide Suspension and Debarment Requirements
- XI. Certification Regarding Use of Contract Funds for Lobbying

ATTACHMENTS

A. Employment and Materials Preference for Appalachian Development Highway System or Appalachian Local Access Road Contracts (included in Appalachian contracts only)

I. GENERAL

1. Form FHWA-1273 must be physically incorporated in each construction contract funded under Title 23 (excluding emergency contracts solely intended for debris removal). The contractor (or subcontractor) must insert this form in each subcontract and further require its inclusion in all lower tier subcontracts (excluding purchase orders, rental agreements and other agreements for supplies or services).

The applicable requirements of Form FHWA-1273 are incorporated by reference for work done under any purchase order, rental agreement or agreement for other services. The prime contractor shall be responsible for compliance by any subcontractor, lower-tier subcontractor or service provider.

Form FHWA-1273 must be included in all Federal-aid design-build contracts, in all subcontracts and in lower tier subcontracts (excluding subcontracts for design services, purchase orders, rental agreements and other agreements for supplies or services). The design-builder shall be responsible for compliance by any subcontractor, lower-tier subcontractor or service provider.

Contracting agencies may reference Form FHWA-1273 in bid proposal or request for proposal documents, however, the Form FHWA-1273 must be physically incorporated (not referenced) in all contracts, subcontracts and lower-tier subcontracts (excluding purchase orders, rental agreements and other agreements for supplies or services related to a construction contract).

2. Subject to the applicability criteria noted in the following sections, these contract provisions shall apply to all work performed on the contract by the contractor's own organization and with the assistance of workers under the contractor's immediate superintendence and to all work performed on the contract by piecework, station work, or by subcontract.

3. A breach of any of the stipulations contained in these Required Contract Provisions may be sufficient grounds for withholding of progress payments, withholding of final payment, termination of the contract, suspension / debarment or any other action determined to be appropriate by the contracting agency and FHWA.

4. Selection of Labor: During the performance of this contract, the contractor shall not use convict labor for any purpose within the limits of a construction project on a Federal-aid highway unless it is labor

performed by convicts who are on parole, supervised release, or probation. The term Federal-aid highway does not include roadways functionally classified as local roads or rural minor collectors.

II. NONDISCRIMINATION

The provisions of this section related to 23 CFR Part 230 are applicable to all Federal-aid construction contracts and to all related construction subcontracts of \$10,000 or more. The provisions of 23 CFR Part 230 are not applicable to material supply, engineering, or architectural service contracts.

In addition, the contractor and all subcontractors must comply with the following policies: Executive Order 11246, 41 CFR 60, 29 CFR 1625-1627, Title 23 USC Section 140, the Rehabilitation Act of 1973, as amended (29 USC 794), Title VI of the Civil Rights Act of 1964, as amended, and related regulations including 49 CFR Parts 21, 26 and 27; and 23 CFR Parts 200, 230, and 633.

The contractor and all subcontractors must comply with: the requirements of the Equal Opportunity Clause in 41 CFR 60-1.4(b) and, for all construction contracts exceeding \$10,000, the Standard Federal Equal Employment Opportunity Construction Contract Specifications in 41 CFR 60-4.3.

Note: The U.S. Department of Labor has exclusive authority to determine compliance with Executive Order 11246 and the policies of the Secretary of Labor including 41 CFR 60, and 29 CFR 1625-1627. The contracting agency and the FHWA have the authority and the responsibility to ensure compliance with Title 23 USC Section 140, the Rehabilitation Act of 1973, as amended (29 USC 794), and Title VI of the Civil Rights Act of 1964, as amended, and related regulations including 49 CFR Parts 21, 26 and 27; and 23 CFR Parts 200, 230, and 633.

The following provision is adopted from 23 CFR 230, Appendix A, with appropriate revisions to conform to the U.S. Department of Labor (US DOL) and FHWA requirements.

1. Equal Employment Opportunity: Equal employment opportunity (EEO) requirements not to discriminate and to take affirmative action to assure equal opportunity as set forth under laws, executive orders, rules, regulations (28 CFR 35, 29 CFR 1630, 29 CFR 1625-1627, 41 CFR 60 and 49 CFR 27) and orders of the Secretary of Labor as modified by the provisions prescribed herein, and imposed pursuant to 23 U.S.C. 140 shall constitute the EEO and specific affirmative action standards for the contractor's project activities under this contract. The provisions of the Americans with Disabilities Act of 1990 (42 U.S.C. 12101 et seq.) set forth under 28 CFR 35 and 29 CFR 1630 are incorporated by reference in this contract. In the execution of this contract, the contractor agrees to comply with the following minimum specific requirement activities of EEO:

a. The contractor will work with the contracting agency and the Federal Government to ensure that it has made every good faith effort to provide equal opportunity with respect to all of its terms and conditions of employment and in their review of activities under the contract.

b. The contractor will accept as its operating policy the following statement:

"It is the policy of this Company to assure that applicants are employed, and that employees are treated during employment, without regard to their race, religion, sex, color, national origin, age or disability. Such action shall include: employment, upgrading, demotion, or transfer; recruitment or recruitment advertising; layoff or termination; rates of pay or other forms of compensation; and selection

for training, including apprenticeship, pre-apprenticeship, and/or on-the-job training."

2. EEO Officer: The contractor will designate and make known to the contracting officers an EEO Officer who will have the responsibility for and must be capable of effectively administering and promoting an active EEO program and who must be assigned adequate authority and responsibility to do so.

3. Dissemination of Policy: All members of the contractor's staff who are authorized to hire, supervise, promote, and discharge employees, or who recommend such action, or who are substantially involved in such action, will be made fully cognizant of, and will implement, the contractor's EEO policy and contractual responsibilities to provide EEO in each grade and classification of employment. To ensure that the above agreement will be met, the following actions will be taken as a minimum:

a. Periodic meetings of supervisory and personnel office employees will be conducted before the start of work and then not less often than once every six months, at which time the contractor's EEO policy and its implementation will be reviewed and explained. The meetings will be conducted by the EEO Officer.

b. All new supervisory or personnel office employees will be given a thorough indoctrination by the EEO Officer, covering all major aspects of the contractor's EEO obligations within thirty days following their reporting for duty with the contractor.

c. All personnel who are engaged in direct recruitment for the project will be instructed by the EEO Officer in the contractor's procedures for locating and hiring minorities and women.

d. Notices and posters setting forth the contractor's EEO policy will be placed in areas readily accessible to employees, applicants for employment and potential employees.

e. The contractor's EEO policy and the procedures to implement such policy will be brought to the attention of employees by means of meetings, employee handbooks, or other appropriate means.

4. Recruitment: When advertising for employees, the contractor will include in all advertisements for employees the notation: "An Equal Opportunity Employer." All such advertisements will be placed in publications having a large circulation among minorities and women in the area from which the project work force would normally be derived.

a. The contractor will, unless precluded by a valid bargaining agreement, conduct systematic and direct recruitment through public and private employee referral sources likely to yield qualified minorities and women. To meet this requirement, the contractor will identify sources of potential minority group employees, and establish with such identified sources procedures whereby minority and women applicants may be referred to the contractor for employment consideration.

b. In the event the contractor has a valid bargaining agreement providing for exclusive hiring hall referrals, the contractor is expected to observe the provisions of that agreement to the extent that the system meets the contractor's compliance with EEO contract provisions. Where implementation of such an agreement has the effect of discriminating against minorities or women, or obligates the contractor to do the same, such implementation violates Federal nondiscrimination provisions.

c. The contractor will encourage its present employees to refer minorities and women as applicants for employment. Information and procedures with regard to referring such applicants will be discussed with employees.

5. Personnel Actions: Wages, working conditions, and employee benefits shall be established and administered, and personnel actions of every type, including hiring, upgrading, promotion, transfer, demotion, layoff, and termination, shall be taken without regard to race, color, religion, sex, national origin, age or disability. The following procedures shall be followed:

a. The contractor will conduct periodic inspections of project sites to insure that working conditions and employee facilities do not indicate discriminatory treatment of project site personnel.

b. The contractor will periodically evaluate the spread of wages paid within each classification to determine any evidence of discriminatory wage practices.

c. The contractor will periodically review selected personnel actions in depth to determine whether there is evidence of discrimination. Where evidence is found, the contractor will promptly take corrective action. If the review indicates that the discrimination may extend beyond the actions reviewed, such corrective action shall include all affected persons.

d. The contractor will promptly investigate all complaints of alleged discrimination made to the contractor in connection with its obligations under this contract, will attempt to resolve such complaints, and will take appropriate corrective action within a reasonable time. If the investigation indicates that the discrimination may affect persons other than the complainant, such corrective action shall include such other persons. Upon completion of each investigation, the contractor will inform every complainant of all of their avenues of appeal.

6. Training and Promotion:

a. The contractor will assist in locating, qualifying, and increasing the skills of minorities and women who are applicants for employment or current employees. Such efforts should be aimed at developing full journey level status employees in the type of trade or job classification involved.

b. Consistent with the contractor's work force requirements and as permissible under Federal and State regulations, the contractor shall make full use of training programs, i.e., apprenticeship, and on-the-job training programs for the geographical area of contract performance. In the event a special provision for training is provided under this contract, this subparagraph will be superseded as indicated in the special provision. The contracting agency may reserve training positions for persons who receive welfare assistance in accordance with 23 U.S.C. 140(a).

c. The contractor will advise employees and applicants for employment of available training programs and entrance requirements for each.

d. The contractor will periodically review the training and promotion potential of employees who are minorities and women and will encourage eligible employees to apply for such training and promotion.

7. Unions: If the contractor relies in whole or in part upon unions as a source of employees, the contractor will use good faith efforts to obtain the cooperation of such unions to increase opportunities for minorities and women. Actions by the contractor, either directly or through a contractor's association acting as agent, will include the procedures set forth below:

a. The contractor will use good faith efforts to develop, in cooperation with the unions, joint training programs aimed toward qualifying more minorities and women for membership in the unions and increasing the skills of minorities and women so that they may qualify for higher paying employment.

b. The contractor will use good faith efforts to incorporate an EEO clause into each union agreement to the end that such union will be contractually bound to refer applicants without regard to their race, color, religion, sex, national origin, age or disability.

c. The contractor is to obtain information as to the referral practices and policies of the labor union except that to the extent such information is within the exclusive possession of the labor union and such labor union refuses to furnish such information to the contractor, the contractor shall so certify to the contracting agency and shall set forth what efforts have been made to obtain such information.

d. In the event the union is unable to provide the contractor with a reasonable flow of referrals within the time limit set forth in the collective bargaining agreement, the contractor will, through independent recruitment efforts, fill the employment vacancies without regard to race, color, religion, sex, national origin, age or disability; making full efforts to obtain qualified and/or qualifiable minorities and women. The failure of a union to provide sufficient referrals (even though it is obligated to provide exclusive referrals under the terms of a collective bargaining agreement) does not relieve the contractor from the requirements of this paragraph. In the event the union referral practice prevents the contractor from meeting the obligations pursuant to Executive Order 11246, as amended, and these special provisions, such contractor shall immediately notify the contracting agency.

8. Reasonable Accommodation for Applicants / Employees with Disabilities: The contractor must be familiar with the requirements for and comply with the Americans with Disabilities Act and all rules and regulations established there under. Employers must provide reasonable accommodation in all employment activities unless to do so would cause an undue hardship.

9. Selection of Subcontractors, Procurement of Materials and Leasing of Equipment: The contractor shall not discriminate on the grounds of race, color, religion, sex, national origin, age or disability in the selection and retention of subcontractors, including procurement of materials and leases of equipment. The contractor shall take all necessary and reasonable steps to ensure nondiscrimination in the administration of this contract.

a. The contractor shall notify all potential subcontractors and suppliers and lessors of their EEO obligations under this contract.

b. The contractor will use good faith efforts to ensure subcontractor compliance with their EEO obligations.

10. Assurance Required by 49 CFR 26.13(b):

a. The requirements of 49 CFR Part 26 and the State DOT's U.S. DOT-approved DBE program are incorporated by reference.

b. The contractor or subcontractor shall not discriminate on the basis of race, color, national origin, or sex in the performance of this contract. The contractor shall carry out applicable requirements of 49 CFR Part 26 in the award and administration of DOT-assisted contracts. Failure by the contractor to carry out these requirements is a material breach of this contract, which may result in the termination of this contract or such other remedy as the contracting agency deems appropriate.

11. Records and Reports: The contractor shall keep such records as necessary to document compliance with the EEO requirements. Such records shall be retained for a period of three years following the date of the final payment to the contractor for all contract work and shall be available at reasonable times and places for inspection by authorized representatives of the contracting agency and the FHWA.

a. The records kept by the contractor shall document the following:

(1) The number and work hours of minority and non-minority group members and women employed in each work classification on the project;

(2) The progress and efforts being made in cooperation with unions, when applicable, to increase employment opportunities for minorities and women; and

(3) The progress and efforts being made in locating, hiring, training, qualifying, and upgrading minorities and women;

b. The contractors and subcontractors will submit an annual report to the contracting agency each July for the duration of the project, indicating the number of minority, women, and non-minority group employees currently engaged in each work classification required by the contract work. This information is to be reported on [Form FHWA-1391](#).

The staffing data should represent the project work force on board in all or any part of the last payroll period preceding the end of July. If on-the-job training is being required by special provision, the contractor will be required to collect and report training data. The employment data should reflect the work force on board during all or any part of the last payroll period preceding the end of July.

III. NONSEGREGATED FACILITIES

This provision is applicable to all Federal-aid construction contracts and to all related construction subcontracts of \$10,000 or more.

The contractor must ensure that facilities provided for employees are provided in such a manner that segregation on the basis of race, color, religion, sex, or national origin cannot result. The contractor may neither require such segregated use by written or oral policies nor tolerate such use by employee custom. The contractor's obligation extends further to ensure that its employees are not assigned to perform their services at any location, under the contractor's control, where the facilities are segregated. The term "facilities" includes waiting rooms, work areas, restaurants and other eating areas, time clocks, restrooms, washrooms, locker rooms, and other storage or dressing areas, parking lots, drinking fountains, recreation or entertainment areas, transportation, and housing provided for employees. The contractor shall provide separate or single-user restrooms and necessary dressing or sleeping areas to assure privacy between sexes.

IV. DAVIS-BACON AND RELATED ACT PROVISIONS

This section is applicable to all Federal-aid construction projects exceeding \$2,000 and to all related subcontracts and lower-tier subcontracts (regardless of subcontract size). The requirements apply to all projects located within the right-of-way of a roadway that is functionally classified as Federal-aid highway. This excludes roadways functionally classified as local roads or rural minor collectors, which are exempt. Contracting agencies may elect to apply these requirements to other projects.

The following provisions are from the U.S. Department of Labor regulations in 29 CFR 5.5 "Contract provisions and related matters" with minor revisions to conform to the FHWA-1273 format and FHWA program requirements.

1. Minimum wages

a. All laborers and mechanics employed or working upon the site of the work, will be paid unconditionally and not less often than once a week, and without subsequent deduction or rebate on any account (except such payroll deductions as are permitted by regulations issued by the Secretary of Labor under the Copeland Act (29 CFR part 3)), the full amount of wages and bona fide fringe benefits (or cash equivalents thereof) due at time of payment computed at rates not less than those contained in the wage determination of the Secretary of Labor which is attached hereto and made a part hereof, regardless of any contractual relationship which may be alleged to exist between the contractor and such laborers and mechanics.

Contributions made or costs reasonably anticipated for bona fide fringe benefits under section 1(b)(2) of the Davis-Bacon Act on behalf of laborers or mechanics are considered wages paid to such laborers or mechanics, subject to the provisions of paragraph 1.d. of this section; also, regular contributions made or costs incurred for more than a weekly period (but not less often than quarterly) under plans, funds, or programs which cover the particular weekly period, are deemed to be constructively made or incurred during such weekly period. Such laborers and mechanics shall be paid the appropriate wage rate and fringe benefits on the wage determination for the classification of work actually performed, without regard to skill, except as provided in 29 CFR 5.5(a)(4). Laborers or mechanics performing work in more than one classification may be compensated at the rate specified for each

classification for the time actually worked therein: Provided, That the employer's payroll records accurately set forth the time spent in each classification in which work is performed. The wage determination (including any additional classification and wage rates conformed under paragraph 1.b. of this section) and the Davis-Bacon poster (WH-1321) shall be posted at all times by the contractor and its subcontractors at the site of the work in a prominent and accessible place where it can be easily seen by the workers.

b. (1) The contracting officer shall require that any class of laborers or mechanics, including helpers, which is not listed in the wage determination and which is to be employed under the contract shall be classified in conformance with the wage determination. The contracting officer shall approve an additional classification and wage rate and fringe benefits therefore only when the following criteria have been met:

(i) The work to be performed by the classification requested is not performed by a classification in the wage determination; and

(ii) The classification is utilized in the area by the construction industry; and

(iii) The proposed wage rate, including any bona fide fringe benefits, bears a reasonable relationship to the wage rates contained in the wage determination.

(2) If the contractor and the laborers and mechanics to be employed in the classification (if known), or their representatives, and the contracting officer agree on the classification and wage rate (including the amount designated for fringe benefits where appropriate), a report of the action taken shall be sent by the contracting officer to the Administrator of the Wage and Hour Division, Employment Standards Administration, U.S. Department of Labor, Washington, DC 20210. The Administrator, or an authorized representative, will approve, modify, or disapprove every additional classification action within 30 days of receipt and so advise the contracting officer or will notify the contracting officer within the 30-day period that additional time is necessary.

(3) In the event the contractor, the laborers or mechanics to be employed in the classification or their representatives, and the contracting officer do not agree on the proposed classification and wage rate (including the amount designated for fringe benefits, where appropriate), the contracting officer shall refer the questions, including the views of all interested parties and the recommendation of the contracting officer, to the Wage and Hour Administrator for determination. The Wage and Hour Administrator, or an authorized representative, will issue a determination within 30 days of receipt and so advise the contracting officer or will notify the contracting officer within the 30-day period that additional time is necessary.

(4) The wage rate (including fringe benefits where appropriate) determined pursuant to paragraphs 1.b.(2) or 1.b.(3) of this section, shall be paid to all workers performing work in the classification under this contract from the first day on which work is performed in the classification.

c. Whenever the minimum wage rate prescribed in the contract for a class of laborers or mechanics includes a fringe benefit which is not expressed as an hourly rate, the contractor shall either pay the benefit as stated in the wage determination or shall pay another bona fide fringe benefit or an hourly cash equivalent thereof.

d. If the contractor does not make payments to a trustee or other third person, the contractor may consider as part of the wages of any laborer or mechanic the amount of any costs reasonably anticipated in providing bona fide fringe benefits under a plan or program, Provided, That the Secretary of Labor has found, upon the written request of the contractor, that the applicable standards of the Davis-Bacon Act have been met. The Secretary of Labor may require the contractor to set aside in a

separate account assets for the meeting of obligations under the plan or program.

2. Withholding

The contracting agency shall upon its own action or upon written request of an authorized representative of the Department of Labor, withhold or cause to be withheld from the contractor under this contract, or any other Federal contract with the same prime contractor, or any other federally-assisted contract subject to Davis-Bacon prevailing wage requirements, which is held by the same prime contractor, so much of the accrued payments or advances as may be considered necessary to pay laborers and mechanics, including apprentices, trainees, and helpers, employed by the contractor or any subcontractor the full amount of wages required by the contract. In the event of failure to pay any laborer or mechanic, including any apprentice, trainee, or helper, employed or working on the site of the work, all or part of the wages required by the contract, the contracting agency may, after written notice to the contractor, take such action as may be necessary to cause the suspension of any further payment, advance, or guarantee of funds until such violations have ceased.

3. Payrolls and basic records

a. Payrolls and basic records relating thereto shall be maintained by the contractor during the course of the work and preserved for a period of three years thereafter for all laborers and mechanics working at the site of the work. Such records shall contain the name, address, and social security number of each such worker, his or her correct classification, hourly rates of wages paid (including rates of contributions or costs anticipated for bona fide fringe benefits or cash equivalents thereof of the types described in section 1(b)(2)(B) of the Davis-Bacon Act), daily and weekly number of hours worked, deductions made and actual wages paid. Whenever the Secretary of Labor has found under 29 CFR 5.5(a)(1)(iv) that the wages of any laborer or mechanic include the amount of any costs reasonably anticipated in providing benefits under a plan or program described in section 1(b)(2)(B) of the Davis-Bacon Act, the contractor shall maintain records which show that the commitment to provide such benefits is enforceable, that the plan or program is financially responsible, and that the plan or program has been communicated in writing to the laborers or mechanics affected, and records which show the costs anticipated or the actual cost incurred in providing such benefits. Contractors employing apprentices or trainees under approved programs shall maintain written evidence of the registration of apprenticeship programs and certification of trainee programs, the registration of the apprentices and trainees, and the ratios and wage rates prescribed in the applicable programs.

b. (1) The contractor shall submit weekly for each week in which any contract work is performed a copy of all payrolls to the contracting agency. The payrolls submitted shall set out accurately and completely all of the information required to be maintained under 29 CFR 5.5(a)(3)(i), except that full social security numbers and home addresses shall not be included on weekly transmittals. Instead the payrolls shall only need to include an individually identifying number for each employee (e.g. , the last four digits of the employee's social security number). The required weekly payroll information may be submitted in any form desired. Optional Form WH-347 is available for this purpose from the Wage and Hour Division Web site at <http://www.dol.gov/esa/whd/forms/wh347instr.htm> or its successor site. The prime contractor is responsible for the submission of copies of payrolls by all subcontractors. Contractors and subcontractors shall maintain the full social security number and current address of each covered worker, and shall provide them upon request to the contracting agency for transmission to the State DOT, the FHWA or the Wage and Hour Division of the Department of Labor for purposes of an investigation or audit of compliance with prevailing wage requirements. It is not a violation of this section for a prime contractor to require a subcontractor to provide addresses and social security numbers to the prime contractor for its own records, without weekly submission to the contracting agency..

(2) Each payroll submitted shall be accompanied by a "Statement of Compliance," signed by the contractor or subcontractor or his or her agent who pays or supervises the payment of the persons employed under the contract and shall certify the following:

(i) That the payroll for the payroll period contains the information required to be provided under §5.5 (a)(3)(ii) of Regulations, 29 CFR part 5, the appropriate information is being maintained under §5.5 (a)(3)(i) of Regulations, 29 CFR part 5, and that such information is correct and complete;

(ii) That each laborer or mechanic (including each helper, apprentice, and trainee) employed on the contract during the payroll period has been paid the full weekly wages earned, without rebate, either directly or indirectly, and that no deductions have been made either directly or indirectly from the full wages earned, other than permissible deductions as set forth in Regulations, 29 CFR part 3;

(iii) That each laborer or mechanic has been paid not less than the applicable wage rates and fringe benefits or cash equivalents for the classification of work performed, as specified in the applicable wage determination incorporated into the contract.

(3) The weekly submission of a properly executed certification set forth on the reverse side of Optional Form WH-347 shall satisfy the requirement for submission of the "Statement of Compliance" required by paragraph 3.b.(2) of this section.

(4) The falsification of any of the above certifications may subject the contractor or subcontractor to civil or criminal prosecution under section 1001 of title 18 and section 231 of title 31 of the United States Code.

c. The contractor or subcontractor shall make the records required under paragraph 3.a. of this section available for inspection, copying, or transcription by authorized representatives of the contracting agency, the State DOT, the FHWA, or the Department of Labor, and shall permit such representatives to interview employees during working hours on the job. If the contractor or subcontractor fails to submit the required records or to make them available, the FHWA may, after written notice to the contractor, the contracting agency or the State DOT, take such action as may be necessary to cause the suspension of any further payment, advance, or guarantee of funds. Furthermore, failure to submit the required records upon request or to make such records available may be grounds for debarment action pursuant to 29 CFR 5.12.

4. Apprentices and trainees

a. Apprentices (programs of the USDOL).

Apprentices will be permitted to work at less than the predetermined rate for the work they performed when they are employed pursuant to and individually registered in a bona fide apprenticeship program registered with the U.S. Department of Labor, Employment and Training Administration, Office of Apprenticeship Training, Employer and Labor Services, or with a State Apprenticeship Agency recognized by the Office, or if a person is employed in his or her first 90 days of probationary employment as an apprentice in such an apprenticeship program, who is not individually registered in the program, but who has been certified by the Office of Apprenticeship Training, Employer and Labor Services or a State Apprenticeship Agency (where appropriate) to be eligible for probationary employment as an apprentice.

The allowable ratio of apprentices to journeymen on the job site in any craft classification shall not be greater than the ratio permitted to the contractor as to the entire work force under the registered program. Any worker listed on a payroll at an apprentice wage rate, who is not registered or otherwise employed as stated above, shall be paid not less than the applicable wage rate on the wage determination for the classification of work actually performed. In addition, any apprentice

performing work on the job site in excess of the ratio permitted under the registered program shall be paid not less than the applicable wage rate on the wage determination for the work actually performed. Where a contractor is performing construction on a project in a locality other than that in which its program is registered, the ratios and wage rates (expressed in percentages of the journeyman's hourly rate) specified in the contractor's or subcontractor's registered program shall be observed.

Every apprentice must be paid at not less than the rate specified in the registered program for the apprentice's level of progress, expressed as a percentage of the journeymen hourly rate specified in the applicable wage determination. Apprentices shall be paid fringe benefits in accordance with the provisions of the apprenticeship program. If the apprenticeship program does not specify fringe benefits, apprentices must be paid the full amount of fringe benefits listed on the wage determination for the applicable classification. If the Administrator determines that a different practice prevails for the applicable apprentice classification, fringes shall be paid in accordance with that determination.

In the event the Office of Apprenticeship Training, Employer and Labor Services, or a State Apprenticeship Agency recognized by the Office, withdraws approval of an apprenticeship program, the contractor will no longer be permitted to utilize apprentices at less than the applicable predetermined rate for the work performed until an acceptable program is approved.

b. Trainees (programs of the USDOL).

Except as provided in 29 CFR 5.16, trainees will not be permitted to work at less than the predetermined rate for the work performed unless they are employed pursuant to and individually registered in a program which has received prior approval, evidenced by formal certification by the U.S. Department of Labor, Employment and Training Administration.

The ratio of trainees to journeymen on the job site shall not be greater than permitted under the plan approved by the Employment and Training Administration.

Every trainee must be paid at not less than the rate specified in the approved program for the trainee's level of progress, expressed as a percentage of the journeyman hourly rate specified in the applicable wage determination. Trainees shall be paid fringe benefits in accordance with the provisions of the trainee program. If the trainee program does not mention fringe benefits, trainees shall be paid the full amount of fringe benefits listed on the wage determination unless the Administrator of the Wage and Hour Division determines that there is an apprenticeship program associated with the corresponding journeyman wage rate on the wage determination which provides for less than full fringe benefits for apprentices. Any employee listed on the payroll at a trainee rate who is not registered and participating in a training plan approved by the Employment and Training Administration shall be paid not less than the applicable wage rate on the wage determination for the classification of work actually performed. In addition, any trainee performing work on the job site in excess of the ratio permitted under the registered program shall be paid not less than the applicable wage rate on the wage determination for the work actually performed.

In the event the Employment and Training Administration withdraws approval of a training program, the contractor will no longer be permitted to utilize trainees at less than the applicable predetermined rate for the work performed until an acceptable program is approved.

c. Equal employment opportunity. The utilization of apprentices, trainees and journeymen under this part shall be in conformity with the equal employment opportunity requirements of Executive Order 11246, as amended, and 29 CFR part 30.

d. Apprentices and Trainees (programs of the U.S. DOT).

Apprentices and trainees working under apprenticeship and skill training programs which have been certified by the Secretary of Transportation as promoting EEO in connection with Federal-aid highway construction programs are not subject to the requirements of paragraph 4 of this Section IV. The straight time hourly wage rates for apprentices and trainees under such programs will be established by the particular programs. The ratio of apprentices and trainees to journeymen shall not be greater than permitted by the terms of the particular program.

5. Compliance with Copeland Act requirements. The contractor shall comply with the requirements of 29 CFR part 3, which are incorporated by reference in this contract.

6. Subcontracts. The contractor or subcontractor shall insert Form FHWA-1273 in any subcontracts and also require the subcontractors to include Form FHWA-1273 in any lower tier subcontracts. The prime contractor shall be responsible for the compliance by any subcontractor or lower tier subcontractor with all the contract clauses in 29 CFR 5.5.

7. Contract termination: debarment. A breach of the contract clauses in 29 CFR 5.5 may be grounds for termination of the contract, and for debarment as a contractor and a subcontractor as provided in 29 CFR 5.12.

8. Compliance with Davis-Bacon and Related Act requirements. All rulings and interpretations of the Davis-Bacon and Related Acts contained in 29 CFR parts 1, 3, and 5 are herein incorporated by reference in this contract.

9. Disputes concerning labor standards. Disputes arising out of the labor standards provisions of this contract shall not be subject to the general disputes clause of this contract. Such disputes shall be resolved in accordance with the procedures of the Department of Labor set forth in 29 CFR parts 5, 6, and 7. Disputes within the meaning of this clause include disputes between the contractor (or any of its subcontractors) and the contracting agency, the U.S. Department of Labor, or the employees or their representatives.

10. Certification of eligibility.

a. By entering into this contract, the contractor certifies that neither it (nor he or she) nor any person or firm who has an interest in the contractor's firm is a person or firm ineligible to be awarded Government contracts by virtue of section 3(a) of the Davis-Bacon Act or 29 CFR 5.12(a)(1).

b. No part of this contract shall be subcontracted to any person or firm ineligible for award of a Government contract by virtue of section 3(a) of the Davis-Bacon Act or 29 CFR 5.12(a)(1).

c. The penalty for making false statements is prescribed in the U.S. Criminal Code, 18 U.S.C. 1001.

V. CONTRACT WORK HOURS AND SAFETY STANDARDS ACT

The following clauses apply to any Federal-aid construction contract in an amount in excess of \$100,000 and subject to the overtime provisions of the Contract Work Hours and Safety Standards Act. These clauses shall be inserted in addition to the clauses required by 29 CFR 5.5(a) or 29 CFR 4.6. As used in this paragraph, the terms laborers and mechanics include watchmen and guards.

1. Overtime requirements. No contractor or subcontractor contracting for any part of the contract work which may require or involve the employment of laborers or mechanics shall require or permit any such laborer or mechanic in any workweek in which he or she is employed on such work to work in excess of forty hours in such workweek unless such laborer or mechanic receives compensation at a rate not less than one

and one-half times the basic rate of pay for all hours worked in excess of forty hours in such workweek.

2. Violation; liability for unpaid wages; liquidated damages. In the event of any violation of the clause set forth in paragraph (1.) of this section, the contractor and any subcontractor responsible therefor shall be liable for the unpaid wages. In addition, such contractor and subcontractor shall be liable to the United States (in the case of work done under contract for the District of Columbia or a territory, to such District or to such territory), for liquidated damages. Such liquidated damages shall be computed with respect to each individual laborer or mechanic, including watchmen and guards, employed in violation of the clause set forth in paragraph (1.) of this section, in the sum of \$10 for each calendar day on which such individual was required or permitted to work in excess of the standard workweek of forty hours without payment of the overtime wages required by the clause set forth in paragraph (1.) of this section.

3. Withholding for unpaid wages and liquidated damages. The FHWA or the contracting agency shall upon its own action or upon written request of an authorized representative of the Department of Labor withhold or cause to be withheld, from any moneys payable on account of work performed by the contractor or subcontractor under any such contract or any other Federal contract with the same prime contractor, or any other federally-assisted contract subject to the Contract Work Hours and Safety Standards Act, which is held by the same prime contractor, such sums as may be determined to be necessary to satisfy any liabilities of such contractor or subcontractor for unpaid wages and liquidated damages as provided in the clause set forth in paragraph (2.) of this section.

4. Subcontracts. The contractor or subcontractor shall insert in any subcontracts the clauses set forth in paragraph (1.) through (4.) of this section and also a clause requiring the subcontractors to include these clauses in any lower tier subcontracts. The prime contractor shall be responsible for compliance by any subcontractor or lower tier subcontractor with the clauses set forth in paragraphs (1.) through (4.) of this section.

VI. SUBLETTING OR ASSIGNING THE CONTRACT

This provision is applicable to all Federal-aid construction contracts on the National Highway System.

1. The contractor shall perform with its own organization contract work amounting to not less than 30 percent (or a greater percentage if specified elsewhere in the contract) of the total original contract price, excluding any specialty items designated by the contracting agency. Specialty items may be performed by subcontract and the amount of any such specialty items performed may be deducted from the total original contract price before computing the amount of work required to be performed by the contractor's own organization (23 CFR 635.116).

a. The term "perform work with its own organization" refers to workers employed or leased by the prime contractor, and equipment owned or rented by the prime contractor, with or without operators. Such term does not include employees or equipment of a subcontractor or lower tier subcontractor, agents of the prime contractor, or any other assignees. The term may include payments for the costs of hiring leased employees from an employee leasing firm meeting all relevant Federal and State regulatory requirements. Leased employees may only be included in this term if the prime contractor meets all of the following conditions:

(1) the prime contractor maintains control over the supervision of the day-to-day activities of the leased employees;

(2) the prime contractor remains responsible for the quality of the work of the leased employees;

(3) the prime contractor retains all power to accept or exclude individual employees from work on the project; and

(4) the prime contractor remains ultimately responsible for the payment of predetermined minimum wages, the submission of payrolls, statements of compliance and all other Federal regulatory requirements.

b. "Specialty Items" shall be construed to be limited to work that requires highly specialized knowledge, abilities, or equipment not ordinarily available in the type of contracting organizations qualified and expected to bid or propose on the contract as a whole and in general are to be limited to minor components of the overall contract.

2. The contract amount upon which the requirements set forth in paragraph (1) of Section VI is computed includes the cost of material and manufactured products which are to be purchased or produced by the contractor under the contract provisions.

3. The contractor shall furnish (a) a competent superintendent or supervisor who is employed by the firm, has full authority to direct performance of the work in accordance with the contract requirements, and is in charge of all construction operations (regardless of who performs the work) and (b) such other of its own organizational resources (supervision, management, and engineering services) as the contracting officer determines is necessary to assure the performance of the contract.

4. No portion of the contract shall be sublet, assigned or otherwise disposed of except with the written consent of the contracting officer, or authorized representative, and such consent when given shall not be construed to relieve the contractor of any responsibility for the fulfillment of the contract. Written consent will be given only after the contracting agency has assured that each subcontract is evidenced in writing and that it contains all pertinent provisions and requirements of the prime contract.

5. The 30% self-performance requirement of paragraph (1) is not applicable to design-build contracts; however, contracting agencies may establish their own self-performance requirements.

VII. SAFETY: ACCIDENT PREVENTION

This provision is applicable to all Federal-aid construction contracts and to all related subcontracts.

1. In the performance of this contract the contractor shall comply with all applicable Federal, State, and local laws governing safety, health, and sanitation (23 CFR 635). The contractor shall provide all safeguards, safety devices and protective equipment and take any other needed actions as it determines, or as the contracting officer may determine, to be reasonably necessary to protect the life and health of employees on the job and the safety of the public and to protect property in connection with the performance of the work covered by the contract.

2. It is a condition of this contract, and shall be made a condition of each subcontract, which the contractor enters into pursuant to this contract, that the contractor and any subcontractor shall not permit any employee, in performance of the contract, to work in surroundings or under conditions which are unsanitary, hazardous or dangerous to his/her health or safety, as determined under construction safety and health standards (29 CFR 1926) promulgated by the Secretary of Labor, in accordance with Section 107 of the Contract Work Hours and Safety Standards Act (40 U.S.C. 3704).

3. Pursuant to 29 CFR 1926.3, it is a condition of this contract that the Secretary of Labor or authorized representative thereof, shall have right of entry to any site of contract performance to inspect or investigate the matter of compliance with the construction safety and health standards and to carry out the duties of the Secretary under Section 107 of the Contract Work Hours and Safety Standards Act (40 U.S.C.3704).

VIII. FALSE STATEMENTS CONCERNING HIGHWAY PROJECTS

This provision is applicable to all Federal-aid construction contracts and to all related subcontracts.

In order to assure high quality and durable construction in conformity with approved plans and specifications and a high degree of reliability on statements and representations made by engineers, contractors, suppliers, and workers on Federal-aid highway projects, it is essential that all persons concerned with the project perform their functions as carefully, thoroughly, and honestly as possible. Willful falsification, distortion, or misrepresentation with respect to any facts related to the project is a violation of Federal law. To prevent any misunderstanding regarding the seriousness of these and similar acts, Form FHWA-1022 shall be posted on each Federal-aid highway project (23 CFR 635) in one or more places where it is readily available to all persons concerned with the project:

18 U.S.C. 1020 reads as follows:

"Whoever, being an officer, agent, or employee of the United States, or of any State or Territory, or whoever, whether a person, association, firm, or corporation, knowingly makes any false statement, false representation, or false report as to the character, quality, quantity, or cost of the material used or to be used, or the quantity or quality of the work performed or to be performed, or the cost thereof in connection with the submission of plans, maps, specifications, contracts, or costs of construction on any highway or related project submitted for approval to the Secretary of Transportation; or

Whoever knowingly makes any false statement, false representation, false report or false claim with respect to the character, quality, quantity, or cost of any work performed or to be performed, or materials furnished or to be furnished, in connection with the construction of any highway or related project approved by the Secretary of Transportation; or

Whoever knowingly makes any false statement or false representation as to material fact in any statement, certificate, or report submitted pursuant to provisions of the Federal-aid Roads Act approved July 1, 1916, (39 Stat. 355), as amended and supplemented;

Shall be fined under this title or imprisoned not more than 5 years or both."

IX. IMPLEMENTATION OF CLEAN AIR ACT AND FEDERAL WATER POLLUTION CONTROL ACT

This provision is applicable to all Federal-aid construction contracts and to all related subcontracts.

By submission of this bid/proposal or the execution of this contract, or subcontract, as appropriate, the bidder, proposer, Federal-aid construction contractor, or subcontractor, as appropriate, will be deemed to have stipulated as follows:

1. That any person who is or will be utilized in the performance of this contract is not prohibited from receiving an award due to a violation of Section 508 of the Clean Water Act or Section 306 of the Clean Air Act.

2. That the contractor agrees to include or cause to be included the requirements of paragraph (1) of this Section X in every subcontract, and further agrees to take such action as the contracting agency may direct as a means of enforcing such requirements.

X. CERTIFICATION REGARDING DEBARMENT, SUSPENSION, INELIGIBILITY AND VOLUNTARY EXCLUSION

This provision is applicable to all Federal-aid construction contracts, design-build contracts, subcontracts, lower-tier subcontracts, purchase orders, lease agreements, consultant contracts or any other covered transaction requiring FHWA approval or that is estimated to cost \$25,000 or more – as defined in 2 CFR Parts 180 and 1200.

1. Instructions for Certification – First Tier Participants:

a. By signing and submitting this proposal, the prospective first tier participant is providing the certification set out below.

b. The inability of a person to provide the certification set out below will not necessarily result in denial of participation in this covered transaction. The prospective first tier participant shall submit an explanation of why it cannot provide the certification set out below. The certification or explanation will be considered in connection with the department or agency's determination whether to enter into this transaction. However, failure of the prospective first tier participant to furnish a certification or an explanation shall disqualify such a person from participation in this transaction.

c. The certification in this clause is a material representation of fact upon which reliance was placed when the contracting agency determined to enter into this transaction. If it is later determined that the prospective participant knowingly rendered an erroneous certification, in addition to other remedies available to the Federal Government, the contracting agency may terminate this transaction for cause of default.

d. The prospective first tier participant shall provide immediate written notice to the contracting agency to whom this proposal is submitted if any time the prospective first tier participant learns that its certification was erroneous when submitted or has become erroneous by reason of changed circumstances.

e. The terms "covered transaction," "debarred," "suspended," "ineligible," "participant," "person," "principal," and "voluntarily excluded," as used in this clause, are defined in 2 CFR Parts 180 and 1200. "First Tier Covered Transactions" refers to any covered transaction between a grantee or subgrantee of Federal funds and a participant (such as the prime or general contract). "Lower Tier Covered Transactions" refers to any covered transaction under a First Tier Covered Transaction (such as subcontracts). "First Tier Participant" refers to the participant who has entered into a covered transaction with a grantee or subgrantee of Federal funds (such as the prime or general contractor). "Lower Tier Participant" refers any participant who has entered into a covered transaction with a First Tier Participant or other Lower Tier Participants (such as subcontractors and suppliers).

f. The prospective first tier participant agrees by submitting this proposal that, should the proposed covered transaction be entered into, it shall not knowingly enter into any lower tier covered transaction with a person who is debarred, suspended, declared ineligible, or voluntarily excluded from participation in this covered transaction, unless authorized by the department or agency entering into this transaction.

g. The prospective first tier participant further agrees by submitting this proposal that it will include the clause titled "Certification Regarding Debarment, Suspension, Ineligibility and Voluntary Exclusion-Lower Tier Covered Transactions," provided by the department or contracting agency, entering into this covered transaction, without modification, in all lower tier covered transactions and in all solicitations for lower tier covered transactions exceeding the \$25,000 threshold.

h. A participant in a covered transaction may rely upon a certification of a prospective participant in a lower tier covered transaction that is not debarred, suspended, ineligible, or voluntarily excluded from the covered transaction, unless it knows that the certification is erroneous. A participant is responsible for ensuring that its principals are not suspended, debarred, or otherwise ineligible to participate in covered transactions. To verify the eligibility of its principals, as well as the eligibility of any lower tier prospective participants, each participant may, but is not required to, check the Excluded Parties List System website (<https://www.epls.gov/>), which is compiled by the General Services Administration.

i. Nothing contained in the foregoing shall be construed to require the establishment of a system of records in order to render in good faith the certification required by this clause. The knowledge and information of the prospective participant is not required to exceed that which is normally possessed by a prudent person in the ordinary course of business dealings.

j. Except for transactions authorized under paragraph (f) of these instructions, if a participant in a covered transaction knowingly enters into a lower tier covered transaction with a person who is suspended, debarred, ineligible, or voluntarily excluded from participation in this transaction, in addition to other remedies available to the Federal Government, the department or agency may terminate this transaction for cause or default.

* * * * *

2. Certification Regarding Debarment, Suspension, Ineligibility and Voluntary Exclusion – First Tier Participants:

a. The prospective first tier participant certifies to the best of its knowledge and belief, that it and its principals:

(1) Are not presently debarred, suspended, proposed for debarment, declared ineligible, or voluntarily excluded from participating in covered transactions by any Federal department or agency;

(2) Have not within a three-year period preceding this proposal been convicted of or had a civil judgment rendered against them for commission of fraud or a criminal offense in connection with obtaining, attempting to obtain, or performing a public (Federal, State or local) transaction or contract under a public transaction; violation of Federal or State antitrust statutes or commission of embezzlement, theft, forgery, bribery, falsification or destruction of records, making false statements, or receiving stolen property;

(3) Are not presently indicted for or otherwise criminally or civilly charged by a governmental entity (Federal, State or local) with commission of any of the offenses enumerated in paragraph (a)(2) of this certification; and

(4) Have not within a three-year period preceding this application/proposal had one or more public transactions (Federal, State or local) terminated for cause or default.

b. Where the prospective participant is unable to certify to any of the statements in this certification, such prospective participant shall attach an explanation to this proposal.

2. Instructions for Certification - Lower Tier Participants:

(Applicable to all subcontracts, purchase orders and other lower tier transactions requiring prior FHWA approval or estimated to cost \$25,000 or more - 2 CFR Parts 180 and 1200)

a. By signing and submitting this proposal, the prospective lower tier is providing the certification set out below.

b. The certification in this clause is a material representation of fact upon which reliance was placed when this transaction was entered into. If it is later determined that the prospective lower tier participant knowingly rendered an erroneous certification, in addition to other remedies available to the Federal Government, the department, or agency with which this transaction originated may pursue available remedies, including suspension and/or debarment.

c. The prospective lower tier participant shall provide immediate written notice to the person to which this proposal is submitted if at any time the prospective lower tier participant learns that its certification was erroneous by reason of changed circumstances.

d. The terms "covered transaction," "debarred," "suspended," "ineligible," "participant," "person," "principal," and "voluntarily excluded," as used in this clause, are defined in 2 CFR Parts 180 and 1200. You may contact the person to which this proposal is submitted for assistance in obtaining a copy of those regulations. "First Tier Covered Transactions" refers to any covered transaction between a grantee or subgrantee of Federal funds and a participant (such as the prime or general contract). "Lower Tier Covered Transactions" refers to any covered transaction under a First Tier Covered Transaction (such as subcontracts). "First Tier Participant" refers to the participant who has entered into a covered transaction with a grantee or subgrantee of

Federal funds (such as the prime or general contractor). "Lower Tier Participant" refers any participant who has entered into a covered transaction with a First Tier Participant or other Lower Tier Participants (such as subcontractors and suppliers).

e. The prospective lower tier participant agrees by submitting this proposal that, should the proposed covered transaction be entered into, it shall not knowingly enter into any lower tier covered transaction with a person who is debarred, suspended, declared ineligible, or voluntarily excluded from participation in this covered transaction, unless authorized by the department or agency with which this transaction originated.

f. The prospective lower tier participant further agrees by submitting this proposal that it will include this clause titled "Certification Regarding Debarment, Suspension, Ineligibility and Voluntary Exclusion-Lower Tier Covered Transaction," without modification, in all lower tier covered transactions and in all solicitations for lower tier covered transactions exceeding the \$25,000 threshold.

g. A participant in a covered transaction may rely upon a certification of a prospective participant in a lower tier covered transaction that is not debarred, suspended, ineligible, or voluntarily excluded from the covered transaction, unless it knows that the certification is erroneous. A participant is responsible for ensuring that its principals are not suspended, debarred, or otherwise ineligible to participate in covered transactions. To verify the eligibility of its principals, as well as the eligibility of any lower tier prospective participants, each participant may, but is not required to, check the Excluded Parties List System website (<https://www.epls.gov/>), which is compiled by the General Services Administration.

h. Nothing contained in the foregoing shall be construed to require establishment of a system of records in order to render in good faith the certification required by this clause. The knowledge and information of participant is not required to exceed that which is normally possessed by a prudent person in the ordinary course of business dealings.

i. Except for transactions authorized under paragraph e of these instructions, if a participant in a covered transaction knowingly enters into a lower tier covered transaction with a person who is suspended, debarred, ineligible, or voluntarily excluded from participation in this transaction, in addition to other remedies available to the Federal Government, the department or agency with which this transaction originated may pursue available remedies, including suspension and/or debarment.

* * * * *

Certification Regarding Debarment, Suspension, Ineligibility and Voluntary Exclusion--Lower Tier Participants:

1. The prospective lower tier participant certifies, by submission of this proposal, that neither it nor its principals is presently debarred, suspended, proposed for debarment, declared ineligible, or voluntarily excluded from participating in covered transactions by any Federal department or agency.

2. Where the prospective lower tier participant is unable to certify to any of the statements in this certification, such prospective participant shall attach an explanation to this proposal.

* * * * *

XI. CERTIFICATION REGARDING USE OF CONTRACT FUNDS FOR LOBBYING

This provision is applicable to all Federal-aid construction contracts and to all related subcontracts which exceed \$100,000 (49 CFR 20).

1. The prospective participant certifies, by signing and submitting this bid or proposal, to the best of his or her knowledge and belief, that:

a. No Federal appropriated funds have been paid or will be paid, by or on behalf of the undersigned, to any person for influencing or attempting to influence an officer or employee of any Federal agency, a Member of

Congress, an officer or employee of Congress, or an employee of a Member of Congress in connection with the awarding of any Federal contract, the making of any Federal grant, the making of any Federal loan, the entering into of any cooperative agreement, and the extension, continuation, renewal, amendment, or modification of any Federal contract, grant, loan, or cooperative agreement.

b. If any funds other than Federal appropriated funds have been paid or will be paid to any person for influencing or attempting to influence an officer or employee of any Federal agency, a Member of Congress, an officer or employee of Congress, or an employee of a Member of Congress in connection with this Federal contract, grant, loan, or cooperative agreement, the undersigned shall complete and submit Standard Form-LLL, "Disclosure Form to Report Lobbying," in accordance with its instructions.

2. This certification is a material representation of fact upon which reliance was placed when this transaction was made or entered into. Submission of this certification is a prerequisite for making or entering into this transaction imposed by 31 U.S.C. 1352. Any person who fails to file the required certification shall be subject to a civil penalty of not less than \$10,000 and not more than \$100,000 for each such failure.

3. The prospective participant also agrees by submitting its bid or proposal that the participant shall require that the language of this certification be included in all lower tier subcontracts, which exceed \$100,000 and that all such recipients shall certify and disclose accordingly.

ATTACHMENT A - EMPLOYMENT AND MATERIALS PREFERENCE FOR APPALACHIAN DEVELOPMENT HIGHWAY SYSTEM OR APPALACHIAN LOCAL ACCESS ROAD CONTRACTS

This provision is applicable to all Federal-aid projects funded under the Appalachian Regional Development Act of 1965.

1. During the performance of this contract, the contractor undertaking to do work which is, or reasonably may be, done as on-site work, shall give preference to qualified persons who regularly reside in the labor area as designated by the DOL wherein the contract work is situated, or the subregion, or the Appalachian counties of the State wherein the contract work is situated, except:

a. To the extent that qualified persons regularly residing in the area are not available.

b. For the reasonable needs of the contractor to employ supervisory or specially experienced personnel necessary to assure an efficient execution of the contract work.

c. For the obligation of the contractor to offer employment to present or former employees as the result of a lawful collective bargaining contract, provided that the number of nonresident persons employed under this subparagraph (1c) shall not exceed 20 percent of the total number of employees employed by the contractor on the contract work, except as provided in subparagraph (4) below.

2. The contractor shall place a job order with the State Employment Service indicating (a) the classifications of the laborers, mechanics and other employees required to perform the contract work, (b) the number of employees required in each classification, (c) the date on which the participant estimates such employees will be required, and (d) any other pertinent information required by the State Employment Service to complete the job order form. The job order may be placed with the State Employment Service in writing or by telephone. If during the course of the contract work, the information submitted by the contractor in the original job order is substantially modified, the participant shall promptly notify the State Employment Service.

3. The contractor shall give full consideration to all qualified job applicants referred to him by the State Employment Service. The contractor is not required to grant employment to any job applicants who, in his opinion, are not qualified to perform the classification of work required.

4. If, within one week following the placing of a job order by the contractor with the State Employment Service, the State Employment Service is unable to refer any qualified job applicants to the contractor, or less than the number requested, the State Employment Service will forward a certificate to the contractor indicating the unavailability of applicants. Such certificate shall be made a part of the contractor's permanent project records. Upon receipt of this certificate, the contractor may employ persons who do not normally reside in the labor area to fill positions covered by the certificate, notwithstanding the provisions of subparagraph (1c) above.

5. The provisions of 23 CFR 633.207(e) allow the contracting agency to provide a contractual preference for the use of mineral resource materials native to the Appalachian region.

6. The contractor shall include the provisions of Sections 1 through 4 of this Attachment A in every subcontract for work which is, or reasonably may be, done as on-site work.

Contract Provision - Cargo Preference Requirements

In accordance with Title 46 CFR § 381.7 (b), the contractor agrees—

“(1) To utilize privately owned United States-flag commercial vessels to ship at least 50 percent of the gross tonnage (computed separately for dry bulk carriers, dry cargo liners, and tankers) involved, whenever shipping any equipment, material, or commodities pursuant to this contract, to the extent such vessels are available at fair and reasonable rates for United States-flag commercial vessels.

(2) To furnish within 20 days following the date of loading for shipments originating within the United States or within 30 working days following the date of loading for shipments originating outside the United States, a legible copy of a rated, ‘on-board’ commercial ocean bill-of-lading in English for each shipment of cargo described in paragraph (b) (1) of this section to both the Contracting Officer (through the prime contractor in the case of subcontractor bills-of-lading) and to the Division of National Cargo, Office of Market Development, Maritime Administration, Washington, DC 20590.

(3) To insert the substance of the provisions of this clause in all subcontracts issued pursuant to this contract.”

Provisions (1) and (2) apply to materials or equipment that are acquired solely for the project. The two provisions do not apply to goods or materials that come into inventories independent of the project, such as shipments of Portland cement, asphalt cement, or aggregates, when industry suppliers and contractors use these materials to replenish existing inventories.

**MINIMUM WAGES FOR FEDERAL AND FEDERALLY
ASSISTED CONSTRUCTION CONTRACTS**

This project is funded, in part, with Federal-aid funds and, as such, is subject to the provisions of the Davis-Bacon Act of March 3, 1931, as amended (46 Sta. 1494, as amended, 40 U.S.C. 276a) and of other Federal statutes referred to in a 29 CFR Part 1, Appendix A, as well as such additional statutes as may from time to time be enacted containing provisions for the payment of wages determined to be prevailing by the Secretary of Labor in accordance with the Davis-Bacon Act and pursuant to the provisions of 29 CFR Part 1. The prevailing rates and fringe benefits shown in the General Wage Determination Decisions issued by the U.S. Department of Labor shall, in accordance with the provisions of the foregoing statutes, constitute the minimum wages payable on Federal and federally assisted construction projects to laborers and mechanics of the specified classes engaged on contract work of the character and in the localities described therein.

General Wage Determination Decisions, modifications and supersedes decisions thereto are to be used in accordance with the provisions of 29 CFR Parts 1 and 5. Accordingly, the applicable decision, together with any modifications issued, must be made a part of every contract for performance of the described work within the geographic area indicated as required by an applicable DBRA Federal prevailing wage law and 29 CFR Part 5. The wage rates and fringe benefits contained in the General Wage Determination Decision shall be the minimum paid by contractors and subcontractors to laborers and mechanics.