

F.A. RTE.	SECTION	COUNTY	TOTAL SHEETS	SHEET NO.
	06-00026-01-MS	MADISON	45	5

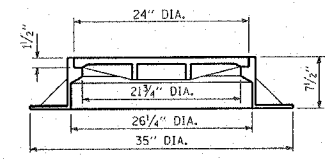

**WATERPROOF FRAME AND BOLTED LID**

ALL MANHOLE FRAMES AND LIDS SHALL BE NEENAH TYPE R-1916D, OR EQUIVALENT. THE MANHOLE LID SHALL HAVE A CONCEALED PICKHOLE LESS THAN 1" IN DIA. AND SHALL HAVE CAST IN THE CENTER THE WORD "SANITARY". MASTIC SEALANT SHALL BE APPLIED BETWEEN THE CONCRETE AND FLANGE OF THE FRAME BEFORE THE LID BOLTS ARE TIGHTENED.

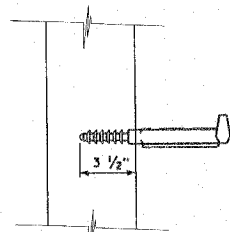

**MANHOLE STEP, PLASTIC**  
NOT TO SCALE

STEPS SHALL BE MADE OF A 3/8" REINFORCING ROD ENCAPSULATED IN A COPOLYMER POLYPROPYLENE PLASTIC AND CONFORMING TO D.S.H.A. REQUIREMENTS.

STEPS SHALL BE 12" WIDE WITH 10" LEGS AND 12" O.C. VERTICAL.

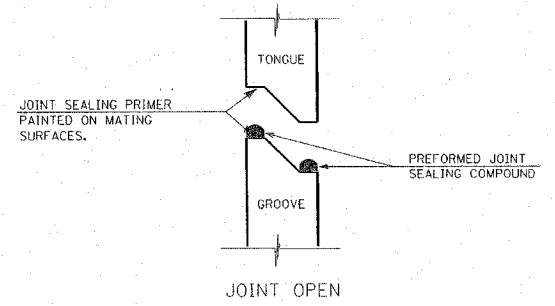

JOINT OPEN

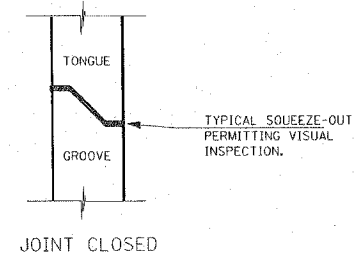

JOINT CLOSED

**WATER TIGHT JOINT DETAIL**  
NOT TO SCALE

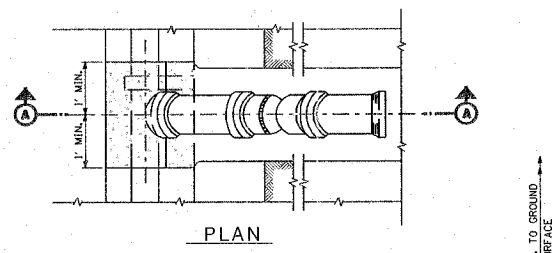

PLAN

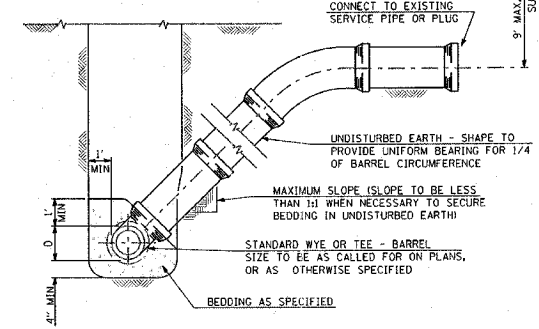

SECTION A-A

**TYPICAL RISER FOR SERVICE LATERAL**  
NOT TO SCALE

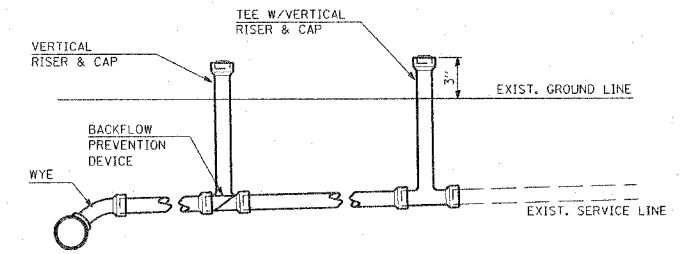

**TYPICAL CLEAN OUT DETAIL**

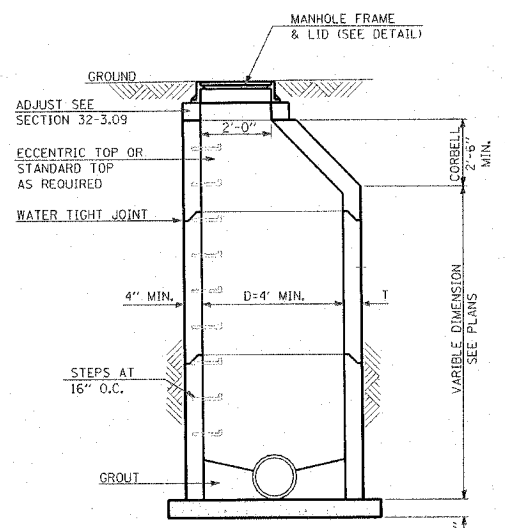

BOTTOM SLAB: 3500 PSI CONCRETE OR PRECAST REINFORCED CONCRETE SLAB ON 6" SAND CUSHION BOTTOM SLAB, MAY BE PRECAST MONOLITHIC WITH MANHOLE WALL SECTION

**SECTION A-A**

IF AREA UNDER THE MANHOLE IS DISTURBED DURING CONSTRUCTION, THE BACKFILL SHALL BE THOROUGHLY COMPACTED TO THE SATISFACTION OF THE ENGINEER.

**MANHOLE, TYPE A**  
NOT TO SCALE

SEPARATE SANITARY SEWER MANHOLES SUBJECT TO SATURATED SOIL CONDITIONS OR SURFACE SUBMERGENCE SHALL BE EQUIPPED WITH CHIMNEY SEALS AND WATER TIGHT MANHOLE COVERS.

MATERIAL WALL THICKNESS (T)  
PRECAST CONC. MIN 1/12 "D"  
CAST-IN-PLACE CONC. MIN. 6"

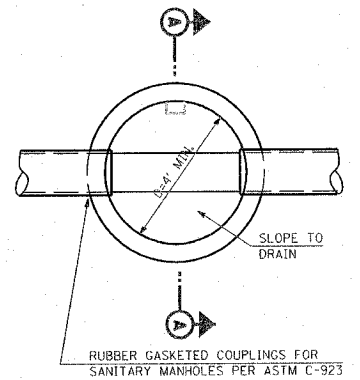

**SECTIONAL PLAN**

STEPS REQUIRED, UNLESS DELETED BY SPECIAL PROVISIONS.

**SANITARY SEWER SYSTEM NOTES AND SPECIFICATIONS**  
(UNLESS NOTED OTHERWISE ELSEWHERE)

- ALL SANITARY SEWER WORK SHALL BE COMPLETED ACCORDING TO THE STANDARD SPECIFICATIONS FOR WATER AND SEWER MAIN CONSTRUCTION, IN ILLINOIS, ADOPTED MAY, 1996, AND LATEST REVISIONS.
- SANITARY SEWER PIPE SHALL BE AS SHOWN ON THE CONSTRUCTION PLANS AND AS DESCRIBED IN THE SPECIAL PROVISIONS
- SEWER LINES SHALL BE LOCATED AT LEAST 10 FEET HORIZONTALLY FROM ANY EXISTING OR PROPOSED WATER MAIN OR SERVICE CONNECTION. THE SEWER LINE SHALL BE SEPARATED FROM A WATER MAIN SO THAT ITS CROWN IS A MINIMUM OF 18 INCHES BELOW THE INVERT OF THE WATER MAIN OR SERVICE EXCEPT AS PROVIDED IN THESE PLANS OR IN THE SPECIAL PROVISIONS.
- ALL MANHOLES SHALL BE TYPE "A" IN DESIGN AND 4' MIN. IN DIAMETER. EQUIPPED WITH A-LOCK RUBBER GASKETS. RISERS AND SLABS SHALL BE ACCORDING TO ASTM C478. LIFTING HOLE SHALL BE PROVIDED IN THE BASES AND RISERS. LIFTING HOOKS SHALL BE PROVIDED IN FLAT SLABS. MANHOLE STEPS SHALL BE CONSTRUCTED OF COPOLYMER POLYPROPYLENE PLASTIC.
- MANHOLES (LEAKAGE TESTING)-PRIOR TO PLACING THE COMPLETED SANITARY SYSTEM IN SERVICE, EACH MANHOLE SHALL BE TESTED FOR LEAKAGE ACCORDING TO ASTM C1244-02. FAILING MANHOLES SHALL BE REPAIRED AND RETESTED AS NECESSARY TO ACHIEVE AN ACCEPTABLE RESULT.
- THE CONTRACTOR SHALL BE RESPONSIBLE FOR MAINTAINING THE REQUIRED SLOPE ON ALL SANITARY SEWER PIPE AND THE REQUIRED ELEVATIONS OF ALL MANHOLES. MINIMUM SLOPE FOR ALL SANITARY SEWER SERVICE PIPE SHALL BE 1/8" PER FOOT.
- CONTRACTOR SHALL PROVIDE 48 HOUR NOTICE OF TESTING FOR OBSERVATION BY VILLAGE OF HARTFORD PUBLIC WORKS DEPARTMENT PERSONNEL.
- THE END OF EACH SERVICE LATERAL SHALL BE MARKED WITH A TREATED 2" BY 4" STAKE LEFT AT LEAST 3 FEET ABOVE THE FINISHED GRADE.
- ALL DISTURBED AREAS, FOR WHATEVER REASON, SHALL BE GRADED TO AS NEAR ITS ORIGINAL STATE AND SEEDED ACCORDING TO THE SPECIAL PROVISIONS.
- SEE TRENCH DETAIL, SHEET AC1-03 FOR SANITARY SEWER INSTALLATION-OPEN CUT INSTALLATION (IF NECESSARY).

211 North Broadway  
Suite 1900  
Madison, Illinois 61702  
Phone: (314) 241-8188  
Fax: (314) 541-0125



**PHASE 2  
LEWIS AND CLARK  
MEMORIAL TOWER**  
HARTFORD, ILLINOIS 62048

**SANITARY SEWER DETAILS**

REV. NO.	DATE	REMARKS

KENNEDY PROJECT NO  
10-02048

ISSUE DATE

SHEET NO.  
**AC1-04**