

F.A.I. RTE.	SECTION	COUNTY	TOTAL SHEETS	SHEET NO.
57/64	(41-3)HBK	JEFFERSON	518	016
STA.	TO STA.			
FED. ROAD DIST. NO.	ILLINOIS	FED. AID PROJECT		
CONTRACT NO. 98963				

**LEGEND:**

- ① PORTLAND CEMENT CONCRETE PAVEMENT, JOINTED 9 1/2"
  - ② SUB-BASE GRANULAR MATERIAL, TYPE A 12 1/2"
  - ③ AGGREGATE SURFACE COURSE, TYPE A 8"
  - ④ AGGREGATE BASE COURSE, TYPE A
  - ⑤ AGGREGATE SHOULDERS TYPE B, 6"
  - ⑥ HOT MIX ASPHALT PAVEMENT (FULL-DEPTH), 12 1/4"
  - ⑦ HOT MIX ASPHALT SURFACE CSE. "MIX D", N50 1 3/4"
  - ⑧ HOT MIX ASPHALT BINDER CSE. IL-19.0, N50 2 1/2"
  - ⑨ HOT MIX ASPHALT SHOULDERS, 8"
  - ⑩ LIME MODIFIED SOIL, 12"
  - ⑪ PORTLAND CEMENT CONCRETE SIDEWALK, 4"
  - ⑫ TOPSOIL FURNISH AND PLACE, 4"
  - ⑬ COMBINATION CONCRETE CURB & GUTTER, TYPE B-6.24
  - ⑭ COMBINATION CONCRETE CURB & GUTTER, TYPE B-6.18
  - ⑮ COMBINATION CONCRETE CURB & GUTTER, TYPE B-6.12
  - ⑯ COMBINATION CONCRETE CURB & GUTTER, TYPE B-6.06
  - ⑰ CONCRETE MEDIAN, TYPE SB-6
  - ⑱ CONCRETE MEDIAN SURFACE, 4"
  - ⑲ NO. 6 EPOXY COATED TIE BARS IN ACCORDANCE WITH STANDARD 420101, SECTION 420 OF THE STANDARD SPECIFICATIONS AND THE FOLLOWING TABLE:
- | LONGITUDINAL JOINT TYPE | BAR SIZE | SPACING |
|-------------------------|----------|---------|
| SAWED CONSTRUCTION      | NO. 6    | 30"     |
|                         | NO. 6    | 24"     |
- ⑳ NO. 6 EPOXY COATED TIE BARS AT 24" CENTERS IN ACCORDANCE WITH STANDARD 606001
  - ㉑ BITUMINOUS MATERIALS (PRIME COAT)
  - ㉒ PAVEMENT MARKINGS (SEE PAVEMENT MARKING PLANS FOR TYPE AND LOCATIONS)
  - ㉓ HOT MIX ASPHALT SURFACE REMOVAL, VARIABLE DEPTH
  - ㉔ LEVELING BINDER, (MACHINE METHOD), N50 2 1/4"
  - ㉕ PORTLAND CEMENT CONCRETE PAVEMENT JOINTED 8 1/2" (UNREINFORCED)
  - ㉖ BITUMINOUS SURFACE TREATMENT, CLASS A-3
  - ㉗ PAVEMENT FABRIC

**NOTE:**  
DOWEL AND TIES BARS SHALL NOT BE PAID FOR SEPARATELY BUT SHALL BE INCLUDED IN THE COST OF CONCRETE PAVEMENT AND/OR CONCRETE CURB AND GUTTER.

REVISIONS	
NAME	DATE

ILLINOIS DEPARTMENT OF TRANSPORTATION  
TYPICAL SECTIONS  
42ND STREET  
VETERANS MEMORIAL DRIVE  
INTERCHANGE  
SECTION (41-3)HBK  
SCALE: NO SCALE  
DATE 3-22-07  
DRAWN BY RL  
CHECKED BY MTM

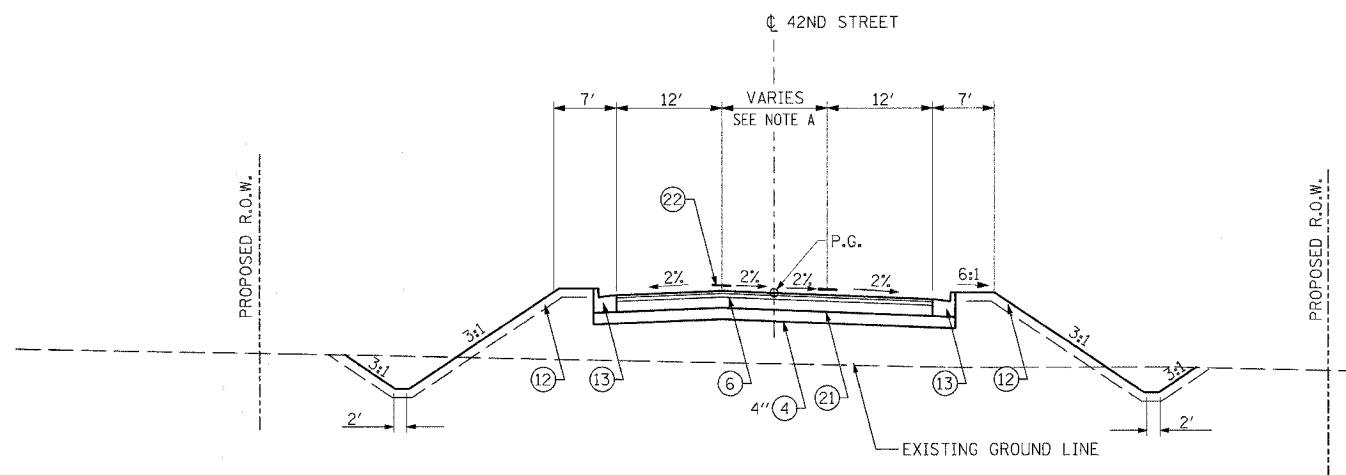

NOTE A:  
MEDIAN TRANSITIONS FROM 15' AT STA. 195+81.70 TO 12.00' AT STA. 197+87.18, SEE PLAN SHEET.  
STA 192+15.22 TO STA 193+85.34 SEE INTERSECTION DETAILS FOR PAVEMENT ELEVATIONS.

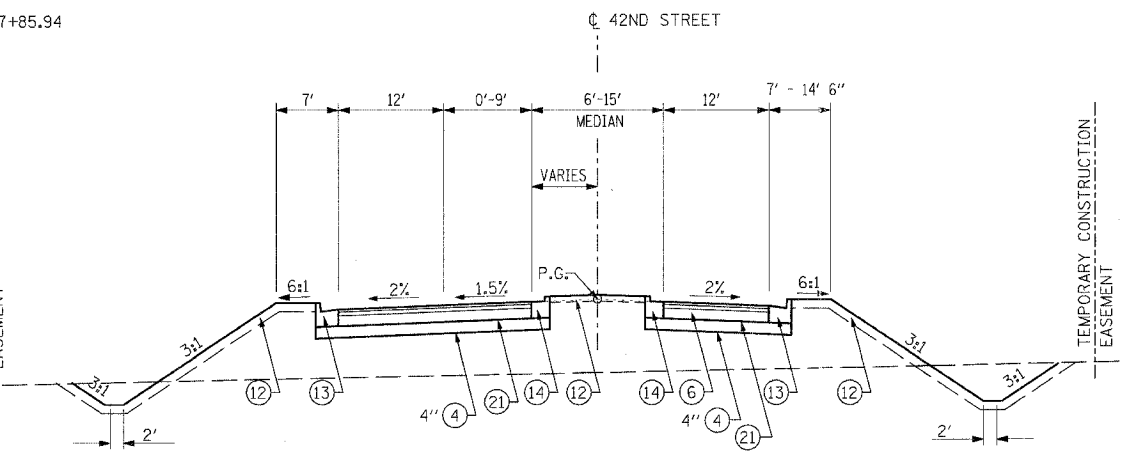
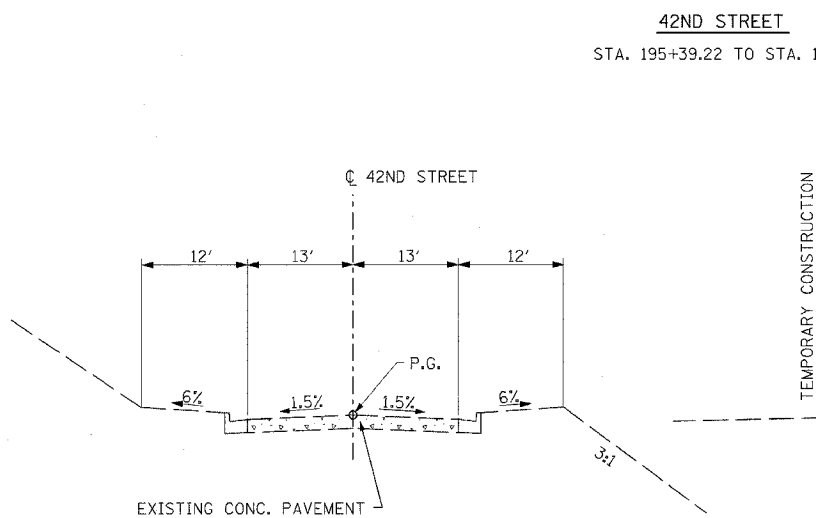

⑥ HOT-MIX ASPHALT PAVEMENT (FULL-DEPTH), 12 1/4"  
1 3/4" HOT-MIX ASPHALT SURFACE CSE, "MIX D", N50  
2 1/2" HOT-MIX ASPHALT BINDER CSE., IL-19.0, N50  
8" HOT-MIX ASPHALT BASE COURSE, N50

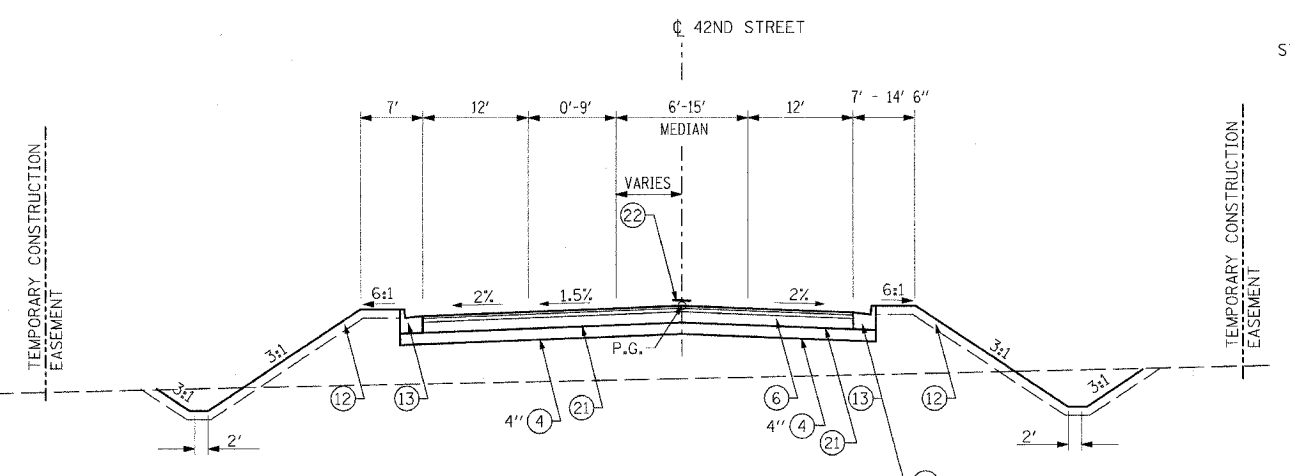

⑥ HOT-MIX ASPHALT PAVEMENT (FULL-DEPTH), 12 1/4"  
1 3/4" HOT-MIX ASPHALT SURFACE CSE, "MIX D", N50  
2 1/2" HOT-MIX ASPHALT BINDER CSE., IL-19.0, N50  
8" HOT-MIX ASPHALT BASE COURSE, N50

42ND STREET  
STA. 192+15.21 TO STA. 193+02.67

Copyright Hanson Professional Services Inc. 2007  
**HANSON**  
 Hanson Professional Services Inc.

03/22/2007 02:47 PM  
 A:\98\98963\98963\Road\Sheet\301\_42.dwg

LAYOUT	RLT	02/26/04
DRAWN	JED	04/12/04
REVIEWED	MTM	03/12/07