

F.A.I. RT#	SECTION	COUNTY	TOTAL SHEETS	SHEET NO.
57/64	(41-3)HBK	JEFFERSON	518	292
STA.	TO STA.			
FED. ROAD DIST. NO.	ILLINOIS	FED. AID PROJECT	CONTRACT NO. 98963	

Sheet 22 of 25

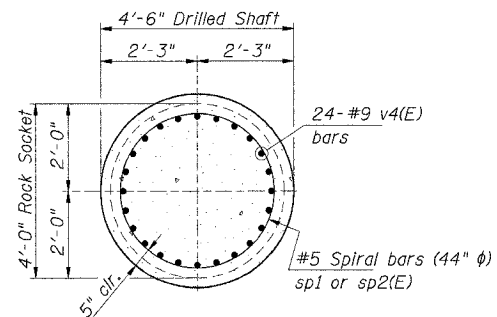

SECTION A-A

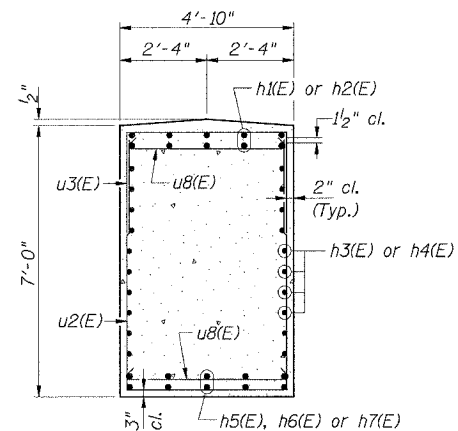

SECTION B-B

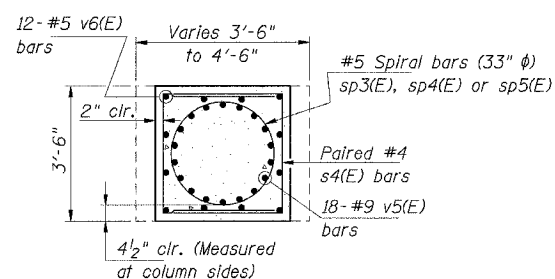

SECTION C-C

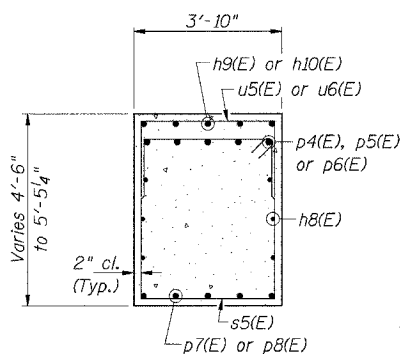

SECTION D-D

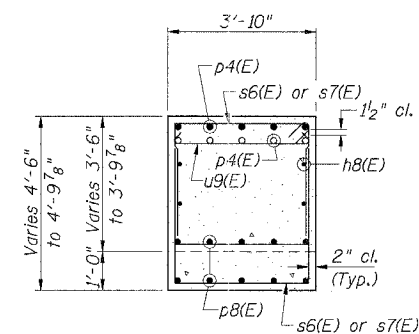

SECTION E-E

A & B DIMENSIONS

Bar	'A'	'B'
s4(E)	3'-2"	3'-2"
s6(E)	3'-6"	3'-5"
s7(E)	3'-6"	3'-2"
u2(E)	4'-6"	6'-7"
u3(E)	4'-6"	2'-7"
u4(E)	4'-0"	2'-7"
u5(E)	3'-6"	2'-8"
u6(E)	3'-6"	3'-1"
u7(E)	3'-4"	2'-7"

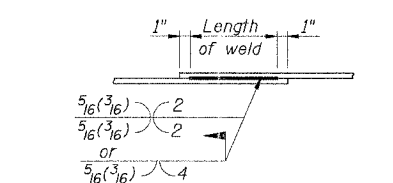
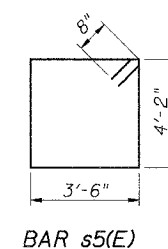
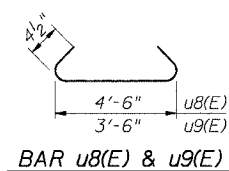
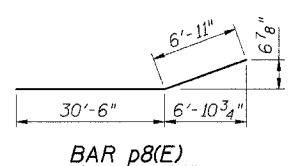
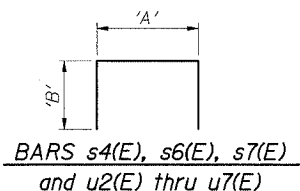

SPIRAL WELDED SPLICE DETAIL

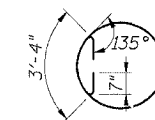

SPIRAL LAP SPLICE DETAIL

Hooks shall be placed to avoid longitudinal reinforcement. Lap splices are not allowed in the confinement zones.

BILL OF MATERIAL

Bar	No.	Size	Length	Shape
h1(E)	10	#9	36'-10"	—
h2(E)	10	#9	48'-11"	—
h3(E)	20	#6	34'-1"	—
h4(E)	20	#6	46'-2"	—
h5(E)	10	#9	30'-9"	—
h6(E)	5	#9	32'-3"	—
h7(E)	10	#9	42'-10"	—
h8(E)	18	#8	33'-3"	—
h9(E)	5	#5	34'-0"	—
h10(E)	10	#5	35'-4"	—
p4(E)	20	#11	23'-11"	—
p5(E)	5	#9	27'-6"	—
p6(E)	5	#9	39'-7"	—
p7(E)	5	#9	32'-3"	—
p8(E)	10	#9	37'-5"	—
s4(E)	210	#4	9'-6"	—
s5(E)	155	#6	16'-8"	—
s6(E)	40	#6	10'-4"	—
s7(E)	40	#6	9'-10"	—
* sp1	7	#5	21'-4"	
* sp2(E)	7	#5	5'-9"	
* sp3(E)	7	#5	5'-9"	
* sp4(E)	7	#5	14'-4"	
* sp5(E)	7	#5	2'-0"	
u2(E)	66	#6	17'-8"	—
u3(E)	66	#6	9'-8"	—
u4(E)	28	#6	9'-2"	—
u5(E)	34	#5	8'-10"	—
u6(E)	35	#5	9'-8"	—
u7(E)	8	#6	8'-6"	—
u8(E)	80	#4	5'-3"	<—
u9(E)	22	#4	4'-3"	<—
v4(E)	168	#9	27'-8"	—
v5(E)	126	#9	24'-2"	—
v6(E)	84	#5	17'-4"	—
Structure Excavation	Cu. Yd.	108		
Drilled Shaft in Soil	Cu. Yd.	68.4		
Drilled Shaft in Rock	Cu. Yd.	16.3		
Concrete Structures	Cu. Yd.	209.7		
Reinforcement Bars, Epoxy Coated	Pound	59570		
Reinforcement Bars	Pound	4970		

* Length of spiral is equal to its required height.

PIER DETAILS (Sheet 2 of 2)
 VETERANS MEMORIAL DR. over F.A.I. ROUTES 57/64
 SECTION (41-3)HBK
 JEFFERSON COUNTY
 STATION 49+72.27
 STRUCTURE NO. 041-0108

© Copyright Hanson Professional Services Inc. 2007



JOB NO.

98S2019A

DATE
03-14-07

March 2007 Submittal
 LAYOUT: MM 03/12/07
 DRAWN: DBS 03/12/07
 REVIEWED: / /
 05/05/2007 03:43 PM
 \$FILE\$
 GBR 12/28/04
 BAK 12/28/04
 REVIEWED: TEH 12/28/04