

F.A.I. RTE.	SECTION	COUNTY	TOTAL SHEETS	SHEET NO.
57/64	(41-3)HBK	JEFFERSON	518	294
STA.		TO STA.		
FED. ROAD DIST. NO.	ILLINOIS	FED. AID PROJECT	CONTRACT NO. 98963	

Sheet 24 of 25

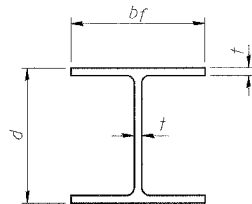

STEEL PILE TABLE

Designation	Depth d	Flange width bf	Web and Flange thickness t	Encasement diameter A
HP 14x117	14 1/4"	14 7/8"	1 3/16"	30"
x102	14"	14 3/4"	1 1/16"	30"
x89	13 7/8"	14 3/4"	5/8"	30"
x73	13 5/8"	14 5/8"	1/2"	30"
HP 12x84	12 1/4"	12 1/4"	1 1/16"	24"
x74	12 1/8"	12 1/4"	5/8"	24"
x63	12"	12 1/8"	1/2"	24"
x53	11 3/4"	12"	7/16"	24"
HP 10x57	10"	10 1/4"	9/16"	24"
x42	9 3/4"	10 1/8"	7/16"	24"
HP 8x36	8"	8 1/8"	7/16"	18"

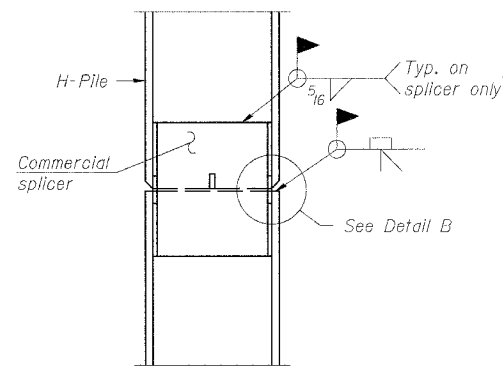

ELEVATION

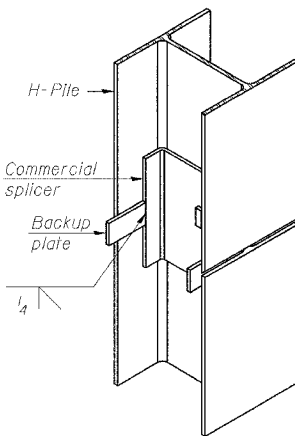

ISOMETRIC VIEW

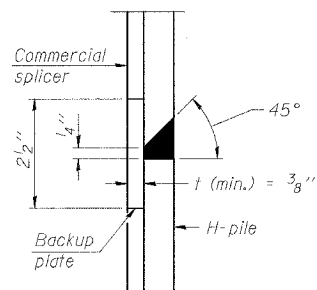

DETAIL "B"

WELDED COMMERCIAL SPLICE

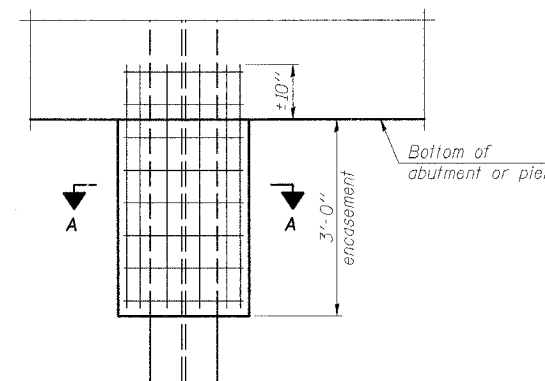

ELEVATION

PILE ENCASUREMENT

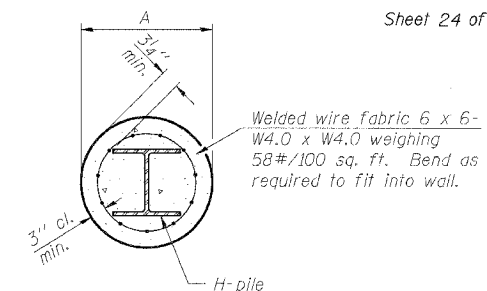

SECTION A-A

Note:
Forms for encasement may be omitted when soil conditions permit.

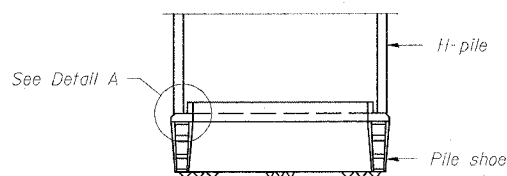

ELEVATION

H-PILE SHOE ATTACHMENT

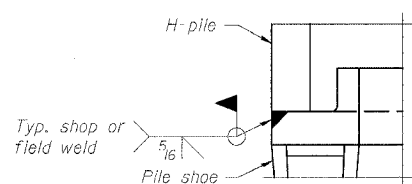

DETAIL A

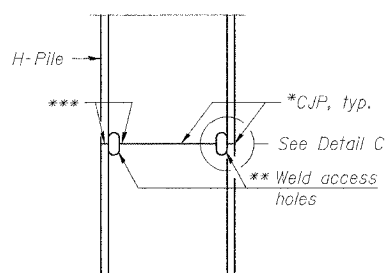

ELEVATION

COMPLETE PENETRATION WELD SPLICE

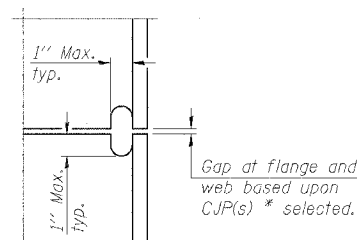

DETAIL C

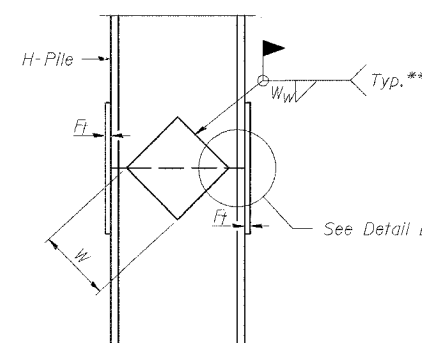

ELEVATION

WELDED PLATE FIELD SPLICE

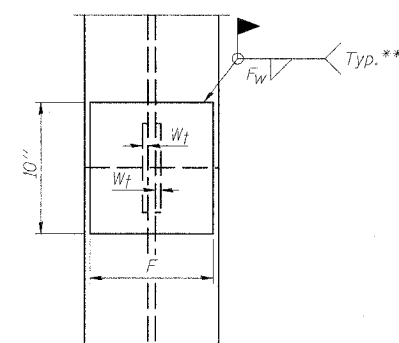

END VIEW

Designation	F	F _t	F _W	W	W _t	W _W
HP 14x117	12 1/2"	1"	7/8"	7 3/4"	5 1/2"	1 1/2"
x102	12 1/2"	7/8"	3/4"	7 3/4"	5 1/2"	1 1/2"
x89	12 1/2"	3/4"	1 1/16"	7 3/4"	5 1/2"	1 1/2"
x73	12 1/2"	5/8"	9/16"	7 3/4"	5 1/2"	1 1/2"
HP 12x84	10"	7/8"	1 1/16"	6 1/2"	5 1/2"	1 1/2"
x74	10"	7/8"	1 1/16"	6 1/2"	5 1/2"	1 1/2"
x63	10"	5/8"	1/2"	6 1/2"	1 1/2"	3/8"
x53	10"	5/8"	1/2"	6 1/2"	1 1/2"	3/8"
HP 10x57	8"	3/4"	9/16"	5 1/4"	1 1/2"	3/8"
x42	8"	5/8"	9/16"	5 1/4"	1 1/2"	3/8"
HP 8x36	7"	5/8"	7/16"	4 1/4"	1 1/2"	3/8"

Note:
The steel H-piles shall be according to AASHTO M270 Grade 50.

- * Use joint conforming to Figure 3.4 in AWS D1.1, Structure Welding Code - Steel.
- ** Preparation per Fig. 5.2 in AWS D1.1, Structure Welding Code - Steel.
- *** Interrupt welds 1/4" from end of each pile.

PILE DETAILS
VETERANS MEMORIAL DR. over F.A.I. ROUTES 57/64
SECTION (41-3)HBK
JEFFERSON COUNTY
STATION 49+72.27
STRUCTURE NO. 041-0108

© Copyright Hanson Professional Services Inc. 2007



DATE
03-14-07

March 2007 Submittal
 LAYOUT MM 03/12/07
 DRAWN DAB 03/12/07
 REVIEWED / /