

- NOTES:
- CURB AND GUTTER ALONG EASTBOUND LANE BEGINS AT STA. 1238+85.
 - SOUTH RIGHT OF WAY LINE INCREASES FROM 60' TO 79' AT STA. 1244+00.
 - SOUTH RIGHT OF WAY LINE TAPERS FROM 79' TO 89' BETWEEN STA. 1244+00 AND STA. 1244+97.

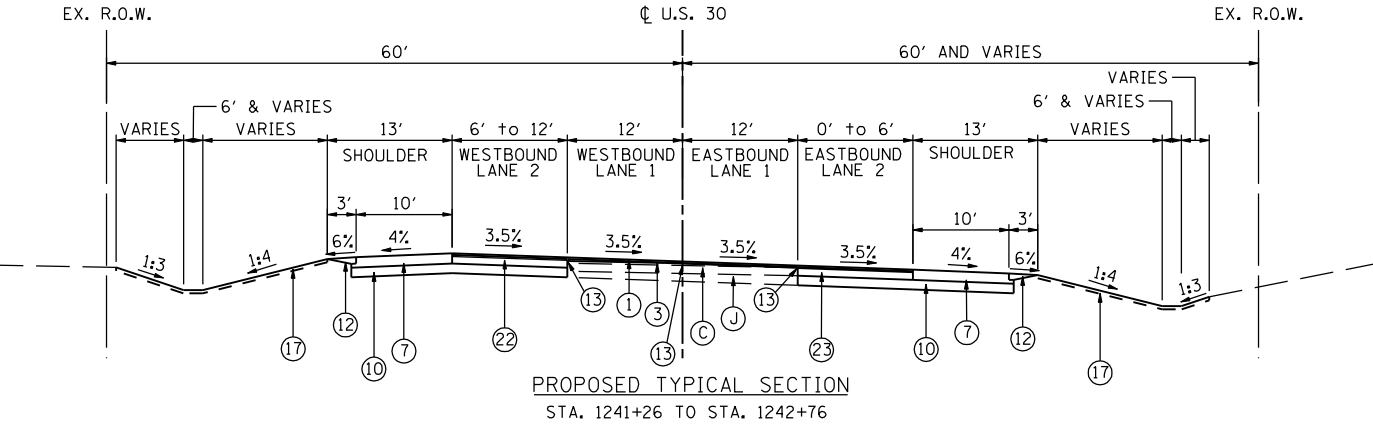
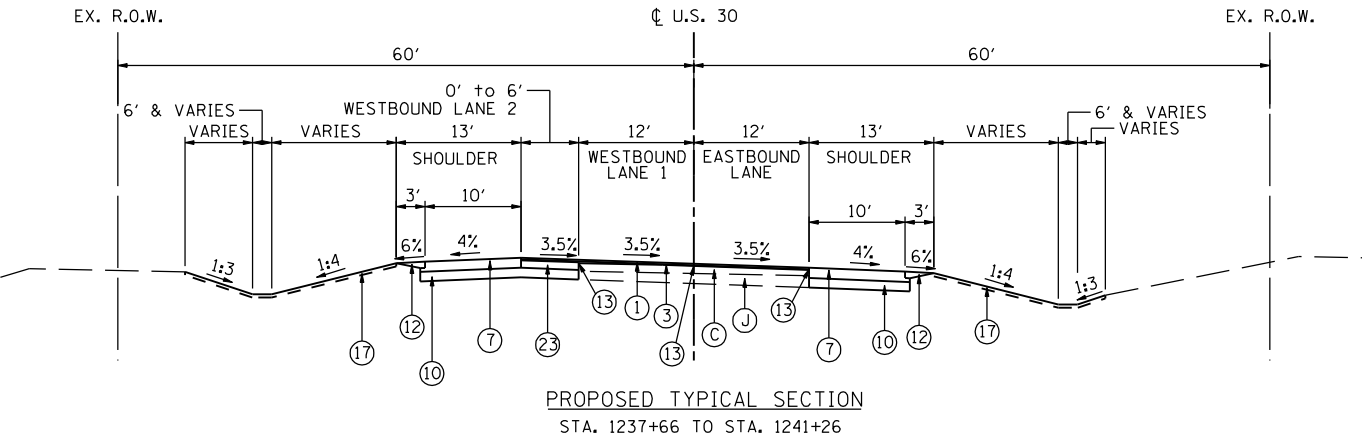

- EXISTING CONDITIONS**
- (A) HOT-MIX ASPHALT SURFACE COURSE 2 1/2"-3"
 - (B) PORTLAND CEMENT CONCRETE PAVEMENT, 10"
 - (C) PORTLAND CEMENT CONCRETE BASE COURSE, 9"-10"
 - (D) HOT-MIX ASPHALT BASE COURSE, 11 1/4"
 - (E) HOT-MIX ASPHALT SHOULDER, 8"
 - (F) AGGREGATE SHOULDER, 6"-8"
 - (G) COMBINATION CONCRETE CURB & GUTTER, TYPE B-6.12 OR B-6.24
 - (H) MEDIAN SURFACE, 12"
 - (I) EXISTING GROUND
 - (J) GRANULAR SUBBASE, THICKNESS VARIES

- PROPOSED IMPROVEMENTS**
- (1) POLYMERIZED HOT-MIX ASPHALT SURFACE COURSE, MIX "F", N90: 2"
 - (2) HOT-MIX ASPHALT SURFACE COURSE, MIX "D", N70: 2"
 - (3) LEVELING BINDER (MACHINE METHOD), N70: 3/4" & VAR. ON US 30, 1" ON IL 31 & VAR.
 - (4) (US 30) HOT-MIX ASPHALT PAVEMENT (FULL DEPTH), 12 3/4" CONSISTING OF: POLYMERIZED HOT-MIX ASPHALT SURFACE COURSE, MIX "F", N90: 2" POLYMERIZED HOT-MIX ASPHALT BINDER COURSE, IL-19.0, N90: 2 1/4" HOT-MIX ASPHALT BINDER COURSE, IL-19.0, N90: 8 1/2"
 - (5) (IL 31) HOT-MIX ASPHALT PAVEMENT (FULL DEPTH), 12 3/4" CONSISTING OF: HOT-MIX ASPHALT SURFACE COURSE, MIX "D", N70: 2" HOT-MIX ASPHALT BINDER COURSE, IL-19.0, N70: 10 3/4"
 - (6) (RAMPS) HOT-MIX ASPHALT PAVEMENT (FULL DEPTH), 12 1/2" CONSISTING OF: HOT-MIX ASPHALT SURFACE COURSE, MIX "D", N70: 2" HOT-MIX ASPHALT BINDER COURSE, IL-19.0, N70: 10 1/2"
 - (7) (US 30 & IL 31) HOT-MIX ASPHALT SHOULDERS, 12 3/4" CONSISTING OF: HOT-MIX ASPHALT SURFACE COURSE, MIX "D", N70: 2" HOT-MIX ASPHALT BINDER COURSE, IL-19.0, N70: 10 3/4"
 - (8) (RAMPS) HOT-MIX ASPHALT SHOULDERS, 12 1/2" CONSISTING OF: HOT-MIX ASPHALT SURFACE COURSE, MIX "D", N70: 2" HOT-MIX ASPHALT BINDER COURSE, IL-19.0, N70: 10 1/2"
 - (9) COMBINATION CONCRETE CURB & GUTTER, TYPE B-6.24
 - (10) AGGREGATE SUBGRADE IMPROVEMENT, 12"
 - (11) AGGREGATE SHOULDER, TYPE B, 8"

- (12) AGGREGATE WEDGE SHOULDER, TYPE B
 - (13) STRIP REFLECTIVE CRACK CONTROL TREATMENT
 - (14) CONCRETE MEDIAN SURFACE, 4"
 - (15) PORTLAND CEMENT CONCRETE PAVEMENT, 10" (JOINTED)
 - (16) PORTLAND CEMENT CONCRETE SHOULDERS, 10"
 - (17) TOPSOIL, FURNISH & PLACE, 4", FERTILIZER NUTRIENTS AND SEEDING OR SODDING. SEE LANDSCAPING PLANS FOR LOCATIONS AND SEEDING TYPE.
 - (18) TOPSOIL, FURNISH & PLACE, 30", FERTILIZER NUTRIENTS, SEEDING CLASS 2A AND EROSION CONTROL BLANKET
- (19) EPOXY COATED, DEFORMED, NO. 6 TIE BARS, 24" LONG @ 24" C-C
 COST INCIDENTAL TO PCC PAV'T, CONC C & G AND CONC MEDIAN TY SB-6
- (20) EPOXY COATED, DEFORMED, NO. 6 TIE BARS, 30" LONG @ 24" C-C
 COST INCIDENTAL TO PCC SHOULDERS, 10"
- (21) EPOXY COATED, DEFORMED, NO. 6 TIE BARS, 24" LONG @ 24" C-C
 COST INCIDENTAL TO CONCRETE BARRIER BASE
- (22) HOT-MIX ASPHALT BASE COURSE, 10"
 - (23) HOT-MIX ASPHALT BASE COURSE WIDENING, 10"

P:\Jobs\2010\20100303\cd\shre\vgm\00\0160133-sht-typical-01.dgn
 6/15/2012 3:03:44 PM

USER NAME = 1654	DESIGNED - JWB	REVISED -
	DRAWN - JWB	REVISED -
PLOT SCALE = 20.0000' / IN.	CHECKED - RS	REVISED -
PLOT DATE = 6/15/2012	DATE - 06/15/2012	REVISED -

**STATE OF ILLINOIS
DEPARTMENT OF TRANSPORTATION**

U.S. ROUTE 30 AT IL ROUTE 31 TYPICAL SECTIONS - U.S. ROUTE 30		
SCALE: N.T.S.	SHEET NO. --	STA. ----- TO STA. -----

F.A.P. RTE.	SECTION	COUNTY	TOTAL SHEETS	SHEET NO.
349	(10 & 11 VB) R-3	*	507	23
* KANE AND KENDALL			CONTRACT NO. 60133	
ILLINOIS FED. AID PROJECT				