

**SCHEDULE OF QUANTITIES**  
HALSTED STREET AT 12TH STREET

NO.	QUANT.	UNIT	DESCRIPTION
1.	0.10	CAL MO	ENGINEER'S FIELD OFFICE, TYPE A
2.	0.05	L SUM	MOBILIZATION
3.	0.05	L SUM	TRAFFIC CONTROL AND PROTECTION, STANDARD 701501
4.	0.05	L SUM	TRAFFIC CONTROL AND PROTECTION, STANDARD 701606
5.	0.05	L SUM	TRAFFIC CONTROL AND PROTECTION, STANDARD 701701
6.	0.05	L SUM	TRAFFIC CONTROL AND PROTECTION, STANDARD 701801
7.	519	FOOT	UNDERGROUND CONDUIT, GALVANIZED STEEL, 2" DIA.
8.	2	EACH	HANDHOLE
9.	1	EACH	MAINTENANCE OF EXISTING TRAFFIC SIGNAL INSTALLATION
10.	1	EACH	TRANSCIEVER - FIBER OPTIC
11.	1,424	FOOT	ELECTRIC CABLE IN CONDUIT, LEAD-IN, NO. 14 1 PAR
12.	2	EACH	DRILL EXISTING HANDHOLE
13.	6	EACH	INDUCTIVE LOOP DETECTOR
14.	127	FOOT	DETECTOR LOOP, TYPE I
15.	1	EACH	REMOVE EXISTING TRAFFIC SIGNAL EQUIPMENT
16.	1	EACH	FULL-ACTUATED CONTROLLER AND TYPE IV CABINET, SPECIAL

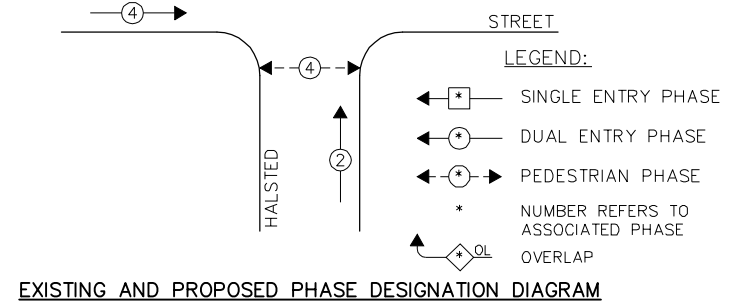
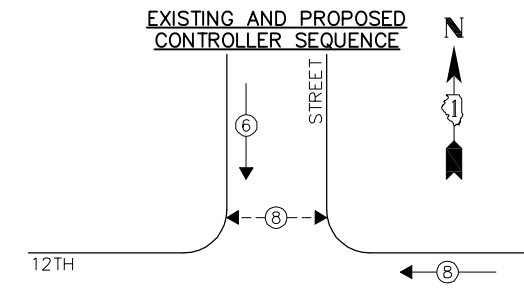
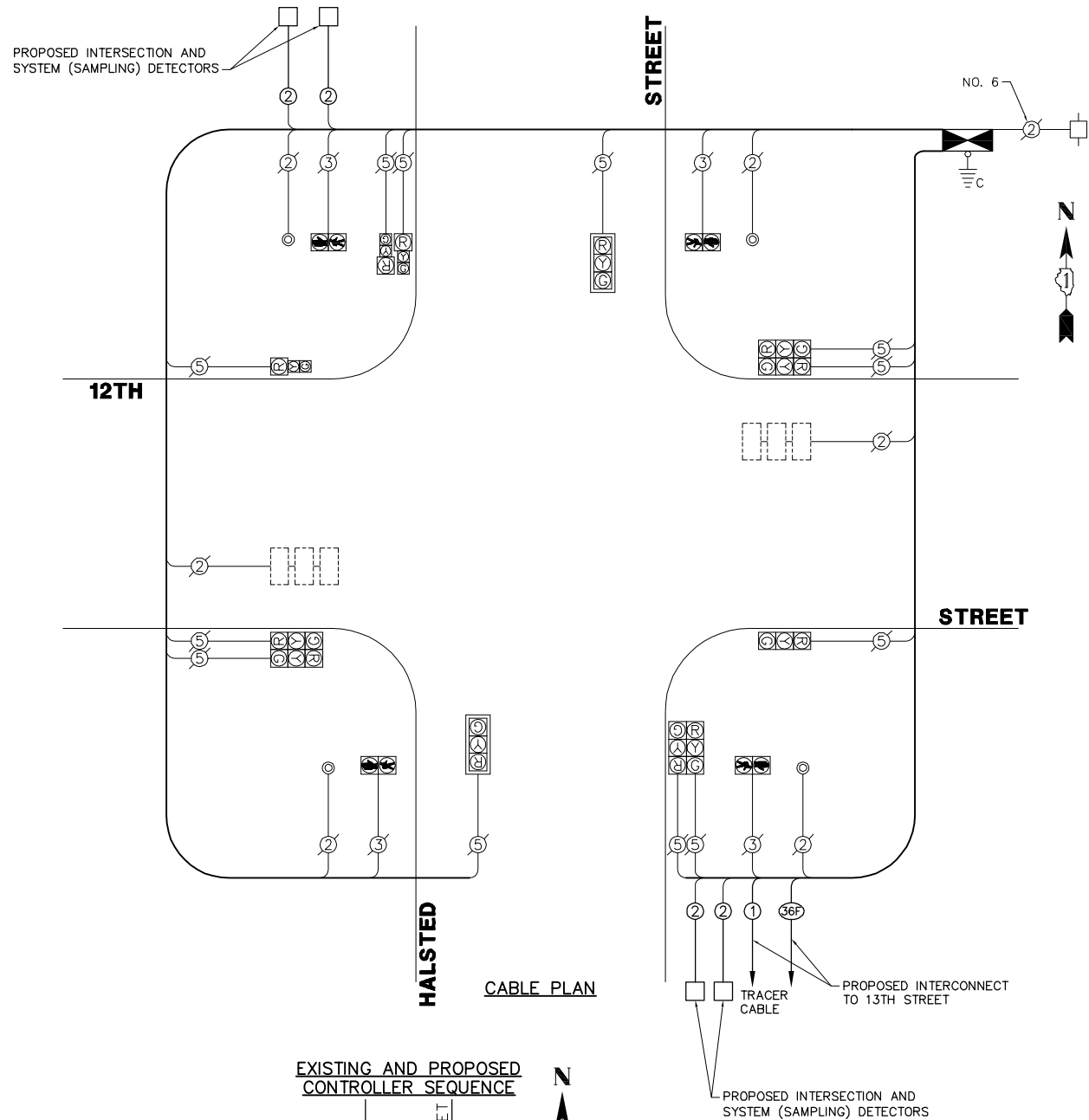

I.D.O.T. TRAFFIC SIGNAL INSTALLATION ELECTRICAL SERVICE REQUIREMENTS					TOTAL WATTAGE
TYPE	NO. LAMPS	WATTAGE		% OPERATION	
SIGNAL (RED)	12	135	17	0.50	810.00
SIGNAL (YELLOW)	12	135	25	0.25	405.00
SIGNAL (GREEN)	12	135	15	0.25	405.00
ARROW	-	135	12	0.10	-
PED. SIGNAL	4	90	25	1.00	360.00
CONTROLLER	1	-	100	1.00	100.00
ILLUM. SIGN	-	-	-	0.05	-
-	-	-	-	-	-
-	-	-	-	-	-
-	-	-	-	-	-
FLASHER	-	-	-	0.50	-
TOTAL =					2080.00

ENERGY COSTS - BILLED TO: CITY OF CHICAGO HEIGHTS  
(ADDRESS) 1601 CHICAGO ROAD  
(ADDRESS) CHICAGO HEIGHTS, IL 60411  
ENERGY SUPPLY - CONTACT: NEW BUSINESS  
PHONE: 1-866-639-3552  
COMPANY: COM. EDISON

THE TRAFFIC SIGNAL CONTROL EQUIPMENT FOR THIS PROJECT SHALL BE "EAGLE" TO MATCH THE EXISTING ADJACENT SYSTEM.

FILE NAME = 4085.883-Cable.dwg	USER NAME = ZACH WALLSTEN	DESIGNED - -	REVISED - -
PLOT SCALE = 1" = .0833'	DATE = 6/28/2012	DRAWN - -	REVISED - -
PLOT DATE = 6/28/2012	DATE = 6/28/2012	CHECKED - -	REVISED - -

**STATE OF ILLINOIS  
DEPARTMENT OF TRANSPORTATION**

**SCHEDULE OF QUANTITIES, CABLE PLAN, AND PHASE  
DESIGNATION DIAGRAM  
HALSTED STREET AT 12TH STREET**

F.A.P. RTE.	SECTION	COUNTY	TOTAL SHEETS	SHEET NO.
-	2012-038TS	COOK	43	27
CONTRACT #:			60786	
ILLINOIS FED. AID PROJECT				

GHA #4085.883