

EROSION CONTROL NOTES:

1. ALL WORK SHALL BE DONE IN ACCORDANCE WITH THE MCHENRY COUNTY AND THE CITY OF MCHENRY STORMWATER ORDINANCES. ALL CONSTRUCTION ACTIVITIES WILL BE IN ACCORDANCE WITH THE NATIONAL POLLUTANT DISCHARGE ELIMINATION SYSTEM STORM WATER PERMIT ILR40. THE CONTRACTOR SHALL ALSO UTILIZE THE STANDARDS AND SPECIFICATIONS IN ACCORDANCE WITH THE ILLINOIS URBAN MANUAL.
2. EROSION CONTROL SHALL BE PROVIDED IN ACCORDANCE WITH THE SEQUENCE OF STAGE CONSTRUCTION. THE CONTRACTOR SHALL SUBMIT A DETAILED SCHEDULE FOR APPROVAL.
3. SEDIMENT AND EROSION CONTROL DEVICES SHALL BE FUNCTIONAL BEFORE THE PROJECT SITE IS OTHERWISE DISTURBED.
4. ALL DISTURBED AREAS SHALL BE SEEDED OR SODDED AS SOON AS PRACTICAL AFTER CONSTRUCTION ACTIVITIES IN THAT AREA HAVE CONCLUDED. THE SURFACE OF STRIPPED AREAS SHALL BE PERMANENTLY OR TEMPORARILY PROTECTED FROM SOIL EROSION WITHIN 14 DAYS AFTER FINAL GRADE IS REACHED. STRIPPED AREAS THAT WILL REMAIN UNDISTURBED FOR MORE THAN 15 DAYS AFTER INITIAL DISTURBANCE SHALL BE PROTECTED FROM EROSION. TEMPORARY SEDIMENT AND EROSION CONTROL MEASURES SHALL BE MAINTAINED CONTINUOUSLY UNTIL PERMANENT COVER IS ESTABLISHED.
5. IF A TOPSOIL STOCKPILE IS TO REMAIN IN PLACE FOR MORE THAN 3 DAYS, EROSION CONTROL MEASURES WILL BE PROVIDED. SOIL STOCKPILES MUST NOT BE LOCATED WITHIN ANY SPECIAL MANAGEMENT AREAS. SPECIAL MANAGEMENT AREAS INCLUDE JURISDICTIONAL WETLANDS AND ADJACENT OFF-SITE WETLANDS.
6. THE CONTRACTOR SHALL TAKE ALL PRECAUTIONS TO PROTECT WETLANDS TO REMAIN FROM DAMAGE BY SEDIMENT, CONSTRUCTION EQUIPMENT OR BY HIS WORK CREWS. THE CONTRACTOR SHALL ASSURE THAT DEBRIS OR ANY CONSTRUCTION MATERIAL IS NOT DISPOSED OF IN WETLANDS.
7. WATER PUMPED OR OTHERWISE DISCHARGED FROM THE SITE DURING CONSTRUCTION DEWATERING SHALL BE FILTERED.
8. WHEN TEMPORARY DRAINAGE IS ESTABLISHED, EROSION CONTROL MEASURES MAY BE REQUIRED BY THE ENGINEER.
9. GRAVEL ROADS, ACCESS DRIVES, PARKING AREAS OF SUFFICIENT WIDTH AND LENGTH, AND VEHICLE WASH DOWN FACILITIES IF NECESSARY, SHALL BE PROVIDED TO PREVENT SOIL FROM BEING TRACKED ONTO PUBLIC OR PRIVATE ROADWAYS. ANY SOIL REACHING A PUBLIC OR PRIVATE ROADWAY SHALL BE REMOVED BEFORE THE END OF EACH WORKDAY AND AS NEEDED.
10. CLEANING OF VEHICLES AND EQUIPMENT, INCLUDING CONCRETE MIXERS, SHALL BE PERFORMED IN A MANNER TO REDUCE THE AMOUNT OF POLLUTANTS TRIBUTARY TO STORM SEWERS AND OPEN WATERS TO THE MAXIMUM EXTENT PRACTICAL.
11. ALL NECESSARY MEASURES SHALL BE TAKEN TO CONTAIN ANY FUEL OR POLLUTION RUNOFF. LEAKING EQUIPMENT OR SUPPLIES SHALL BE IMMEDIATELY REPAIRED OR REMOVED FROM THE SITE.
12. SEDIMENT COLLECTED DURING CONSTRUCTION BY THE VARIOUS TEMPORARY EROSION CONTROL SYSTEMS SHALL BE DISPOSED OF ON THE SITE ON A REGULAR BASIS. SEDIMENT SHALL BE REMOVED FROM EROSION CONTROL SYSTEMS WHEN THE HEIGHT OF THE SEDIMENT EXCEEDS ONE-HALF OF THE HEIGHT OF THE FILTER DEVICE.
13. THE ENGINEER SHALL INSPECT EROSION CONTROL MEASURES WEEKLY AND WITHIN 24 HOURS OF ANY STORM EXCEEDING 1/2 INCH PRECIPITATION. DAMAGED AND INEFFECTIVE EROSION CONTROL MEASURES SHALL BE REPAIRED OR REPLACED WITHIN 72 HOURS. EROSION CONTROL SYSTEMS REPLACED DUE TO SEDIMENT LOADING WILL BE PAID FOR AT THE CONTRACT UNIT PRICE FOR THE APPLICABLE EROSION CONTROL ITEM.
14. ALL SEDIMENT AND EROSION CONTROL MEASURES WILL BE PAID FOR IN ACCORDANCE WITH SECTION 280 OF THE STANDARD SPECIFICATIONS, EXCEPT WHERE OTHERWISE NOTED IN THE CONTRACT SPECIAL PROVISIONS.
15. THE COST OF REPAIRING OR REMOVING SEDIMENT FROM EROSION CONTROL SYSTEMS SHALL BE INCLUDED IN THE CONTRACT UNIT PRICE FOR THE APPLICABLE EROSION CONTROL ITEM.
16. ALL EROSION CONTROL MEASURES SHALL BE KEPT OPERATIONAL AND MAINTAINED CONTINUOUSLY THROUGHOUT THE PERIOD OF LAND DISTURBANCE UNTIL PERMANENT SEDIMENT AND EROSION CONTROL MEASURES ARE OPERATIONAL.
17. TREES TO BE PROTECTED DURING CONSTRUCTION SHOULD BE IDENTIFIED BY THE ENGINEER AND BE IN ACCORDANCE TO THE DETAILS PROVIDED IN THE PLANS, AND SHALL BE PAID FOR AS TEMPORARY FENCE.

BOX CULVERT EXTENSION:

1. APPROPRIATE SOIL EROSION AND SEDIMENT CONTROL METHODS WILL BE INCLUDED FOR EACH STEP OF THE BOX CULVERT EXTENSION BY THE CONTRACTOR AND RESIDENT ENGINEER. AT A MINIMUM, THE WORK AREA NEEDS TO BE ISOLATED FROM ANY FLOWING WATER. THIS SHOULD BE DONE BY EITHER BY-PASS PUMPING OR BY-PASS PIPING THE FLOW AROUND THE WORK AREA. PROTECTION MUST BE PROVIDED UP TO THE EXISTING 10 YEAR HIGHWATER ELEVATION. ROCK CHECK DAMS ARE SPECIFIED, BUT OTHER METHODS INCLUDING BUT NOT LIMITED TO SANDBAGS AND WATER INFLATED DAMS MAY BE USED UPON APPROVAL BY THE RESIDENT ENGINEER.
2. A SUMP PIT SHALL BE USED DURING DEWATERING OPERATIONS OF THE WORK AREA AS SHOWN ON THE PLAN AND SHALL BE DISCHARGED TO A SEDIMENT BAG OF ADEQUATE SIZE TO PROVIDE FOR SEDIMENT COLLECTION PRIOR TO DISCHARGE TO THE DRAINAGE SYSTEM.
3. WATER CAPTURED UPSTREAM OF THE COFFERDAM MAY BE DISCHARGED DIRECTLY BACK INTO THE DRAINAGE SYSTEM AS LONG AS NO SCOURING OCCURS FROM THE DRAINAGE OPERATION.
4. THE MCHENRY COUNTY SOIL AND WATER CONSERVATION DISTRICT WILL BE CONTACTED SEVEN (7) DAYS BEFORE ANY IN-STREAM WORK BEGINS TO ENSURE ADEQUATE SESC PRACTICES ARE IN PLACE BEFORE CONSTRUCTION BEGINS. THE MCSWCD HAS PERMISSION TO ACCESS THE SITE TO VERIFY THAT SEDIMENT AND EROSION CONTROL PRACTICES ARE WORKING PROPERLY AND TO DETERMINE IF ADDITIONAL PRACTICES ARE NEEDED. IF ADDITIONAL PRACTICES ARE DEEMED NECESSARY BY THE MCSWCD THE CONTRACTOR SHALL IMPLEMENT THE PRACTICES IN A TIMELY MANNER.

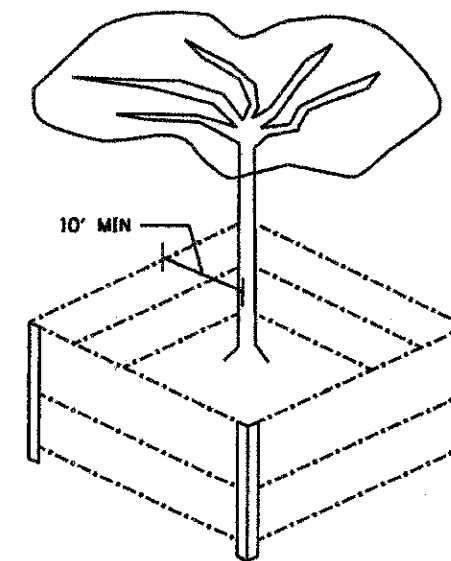

TREE TRUNK PROTECTION FOR MEDIUM AND LARGE TREES

COMPANY NAME: HRGreen
 PROJECT CONTACT: 7/23/2012 10:35:41 AM
 CLIENT: 090071-erode.tbl
 FILE NAME: 090071-erode.tbl.dgn
 PLOT DRIVER: DefPlot
 PEN TABLE: standard-trans.tbl

HRGreen.com
 Illinois Professional Design Firm
 # 184-001322

USER NAME = jottens	DESIGNED = DCJ	REVISED =
FILE NAME = 090071-erode.tbl.dgn	DRAWN = DCJ	REVISED =
PLOT SCALE = N/A	CHECKED = JLP	REVISED =
PLOT DATE = 7/23/2012	DATE = 7/23/12	REVISED =

MCHENRY COUNTY DIVISION OF TRANSPORTATION

**EROSION AND SEDIMENT CONTROL DETAILS
CHARLES J. MILLER ROAD ROADWAY IMPROVEMENTS**

SCALE: N/A SHEET NO. 4 OF 5 SHEETS STA. TO STA.

F.A.U. RTE.	SECTION	COUNTY	TOTAL SHEETS	SHEET NO.
3860	09-C0372-00-PW	MCHENRY	252	99
CONTRACT NO. 63633			ILLINOIS FED. AID PROJECT	