

DETAIL - GROUND MOUNTED RAIL POST

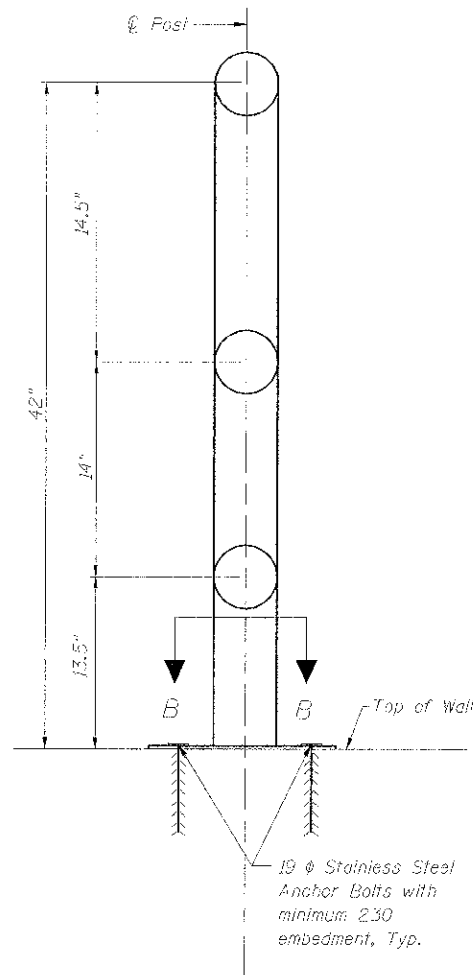

DETAIL - WALL MOUNTED RAIL POST

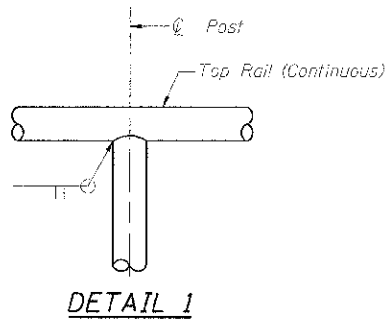

DETAIL 1

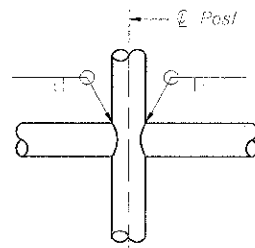

DETAIL 2

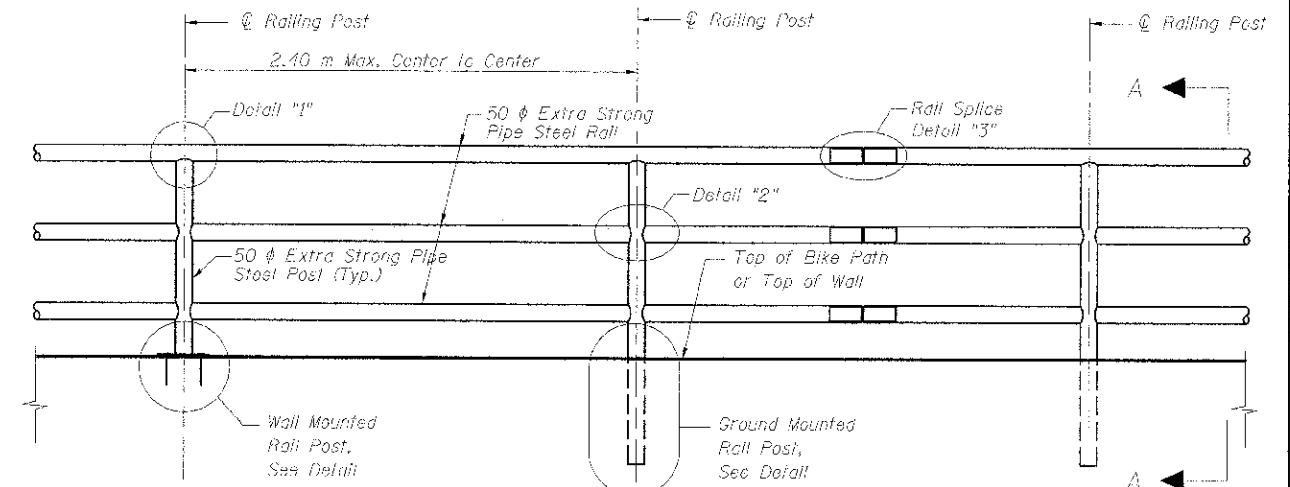

TYPICAL BICYCLE RAILING ELEVATION

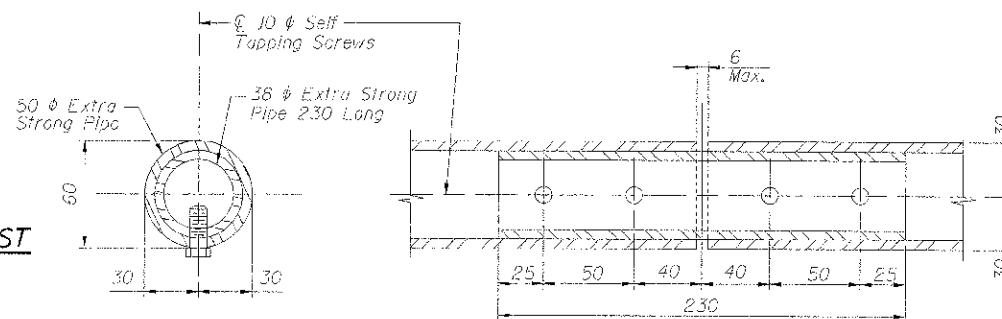

DETAIL 3 - RAIL SPLICE

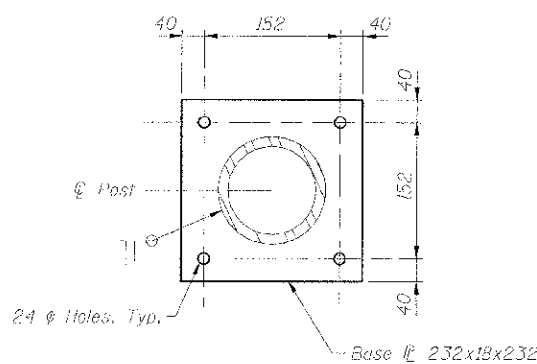

SECTION B-B

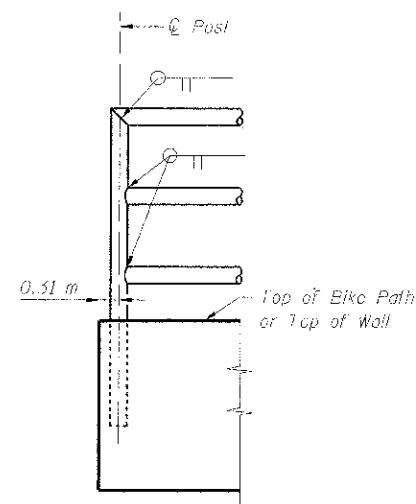

ELEVATION SHOWING END POST

NOTES:

1. The Contractor shall submit design, construction plans with material information, and shop drawings, including connection details, signed by a Structural Engineer licensed in the state of Illinois to the Engineer for approval before ordering materials.
2. Railing shall be according to Section 509 of the Standard Specifications, except as noted, and will be paid for at the contract unit price per meter.
3. Hollow structural steel tubing shall conform to the requirements of ASTM designation A 500, Grade B, Structural Steel Tubing.
4. All other steel shapes and plates shall conform to the requirements of AASHTO M-270M, Grade 345.
5. All posts, railing, splices, anchor devices, and bent plates shall be galvanized after shop fabrication according to AASHTO M-111 and ASTM A-385. All bolts, nuts and washers shall be galvanized according to AASHTO M-232 except stainless steel bolts as noted.
6. Vent holes for galvanizing shall be placed in the posts and rails at locations that will not allow the accumulation of moisture in the members.
7. Rail to match profile of Sidewalk.

FILE NAME: \\snp\p01\projects\11-00049-00-SW\Drawings\Structure\Bike Railing Details.dgn



100 SWACKER DR.
SUITE 500
CHICAGO IL 60605
TEL (312) 939-1000
FAX (312) 939-4990

USER NAME: KJSEPA
DESIGNED: KLM
DRAWN: KLM
CHECKED: DDI
DATE: JUNE 29, 2012
PLOT SCALE: 24.000000 1/1 FT.
PLOT DATE: 7/2/2012

DESIGNED: KLM
DRAWN: KLM
CHECKED: DDI
DATE: JUNE 29, 2012

REVISED: -
REVISED: -
REVISED: -
REVISED: -

STATE OF ILLINOIS
DEPARTMENT OF TRANSPORTATION

SOUTHWEST HIGHWAY SIDEWALK
BIKE RAILING DETAILS

F.A.J. RTE. 3578	SECTION 11-00049-00-SW	COUNTY COOK	TOTAL SHEETS 29	SHEET NO. 19
CONTRACT NO. 63732				ILLINOIS FED. AID PROJECT

SCALE: DRAWING NO. OF STA. TO STA.