

F.A.I. RTE.	SECTION	COUNTY	TOTAL SHEETS	SHEET NO.
90/94		COOK	312	210
STA.		TO STA.		
60A62		• (1919.15, 2021-922 PT1 & PT2) R-1		

COMB CONC C&G, TY M-4.24 TRANSITION TO BRIDGE ABUTMENT
N.T.S.

STA 4417+43.35
STA 4426+45.57
STA 4449+52.82

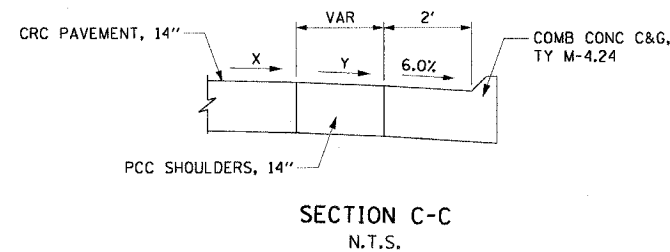
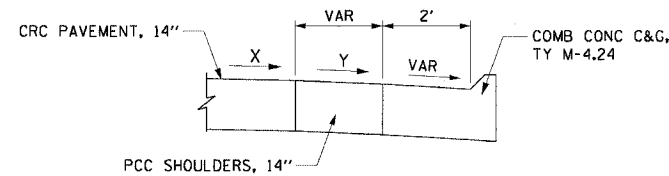
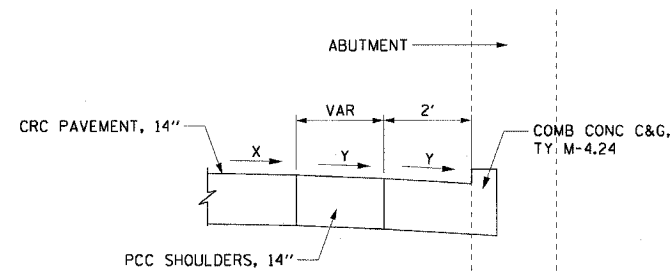
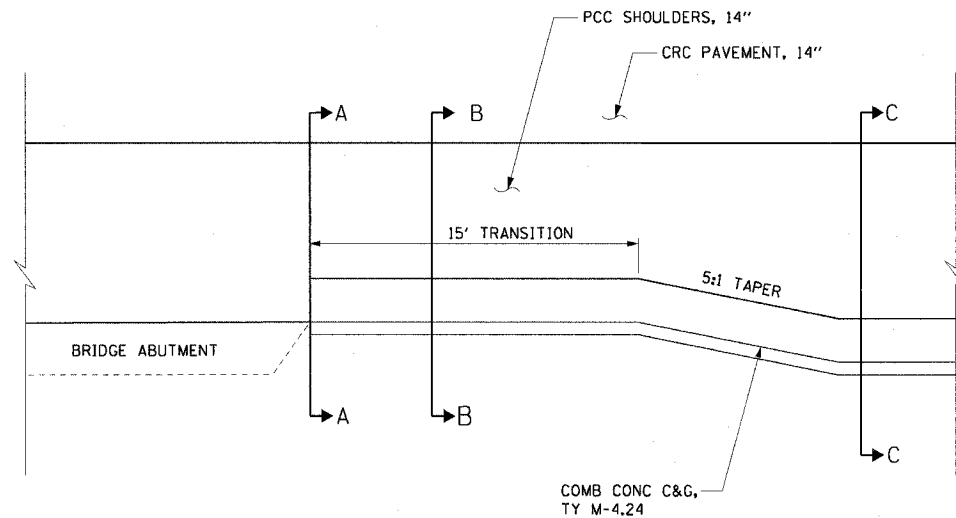

NOTE:
THE TRANSITION SECTION SHALL BE PAID FOR AS COMB CONC C&G, TY M-4.24.

STATION	X	Y
4417+43.35	6%	6%
4426+45.57	1.5%	4%
4449+52.82	1.5%	4%

SINGLE FACE CONCRETE BARRIER TRANSITION TO PIER/ABUTMENT/RETAINING WALL
N.T.S.

STA 6070+47.70 RT STA 4447+55.98 LT
STA 6073+20.80 RT STA 4448+69.91 RT
STA 4422+12.57 RT STA 4448+70.22 LT
STA 4422+96.04 RT STA 4449+19.41 LT
STA 4425+73.57 RT STA 4474+10.95 RT
STA 4447+35.61 LT

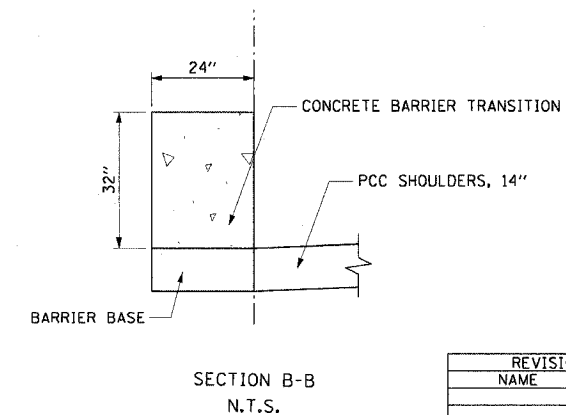
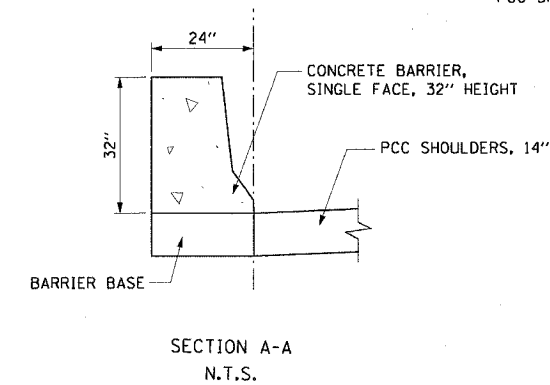
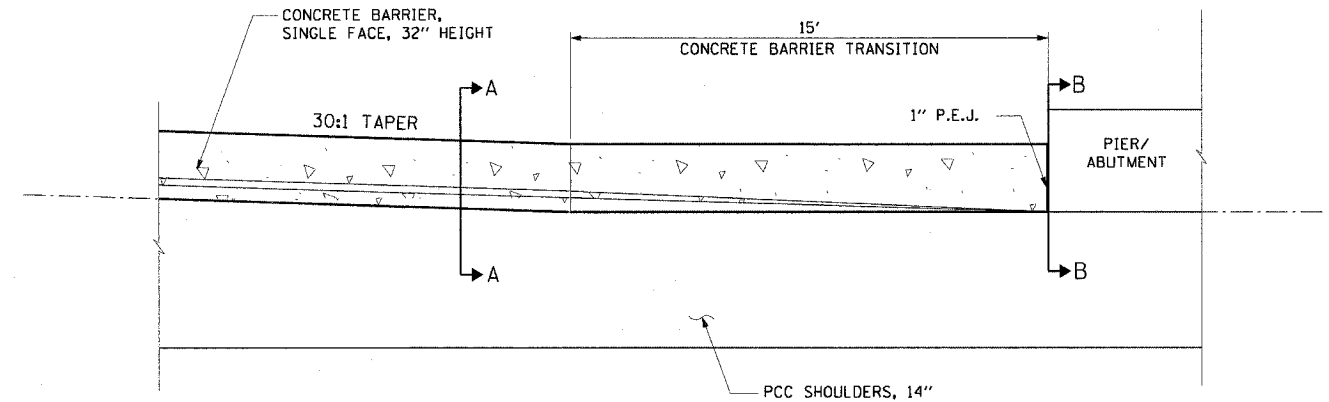

- NOTES:
1. THE 1" PREFORMED EXPANSION JOINT SHALL BE INCLUDED IN THE COST OF CONCRETE BARRIER TRANSITION.
 2. SEE RDT-2 FOR CONCRETE BARRIER, SINGLE FACE, 32" HEIGHT DETAILS.

REVISIONS	
NAME	DATE

ILLINOIS DEPARTMENT OF TRANSPORTATION
F.A.I. 90/94 (DAN RYAN EXPRESSWAY)
63RD STREET TO GARFIELD BLVD (NB LOCAL LANES)

ROADWAY DETAILS
COMB CONC C&G TRANSITION TO ABUTMENT
SINGLE FACE CONCRETE BARRIER TRANSITION

SCALE: NONE DRAWN BY: NJH
DATE: June 9, 2006 CHECKED BY: RMG

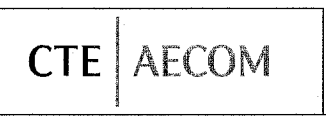

RDT-3
9/3/09 AM
6/5/2006