

DETAIL A - EXISTING

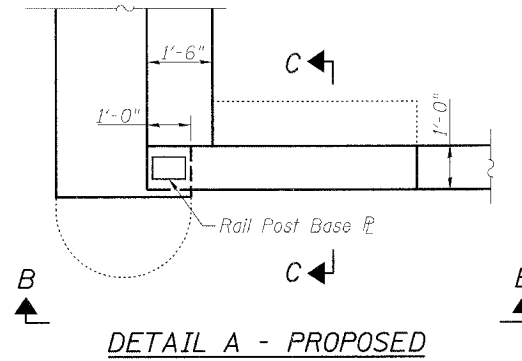

DETAIL A - PROPOSED

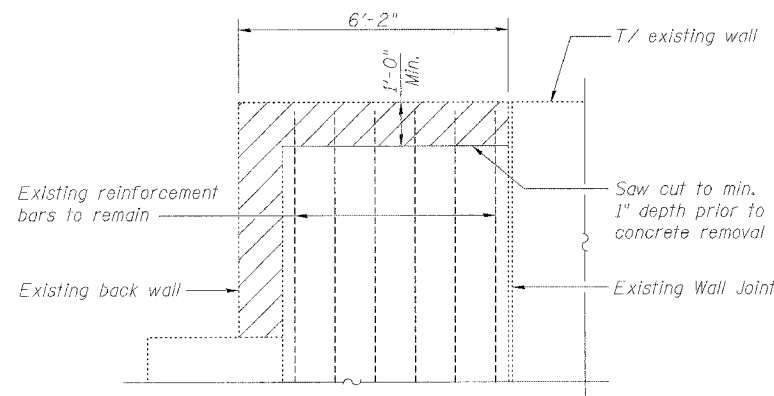

ELEVATION B-B - EXISTING
Circular portion omitted for clarity

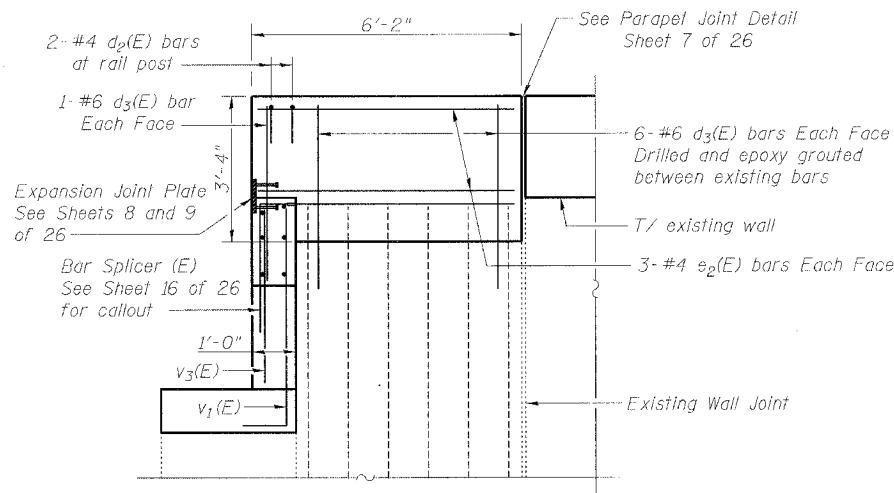

ELEVATION B-B - PROPOSED
Circular portion omitted for clarity

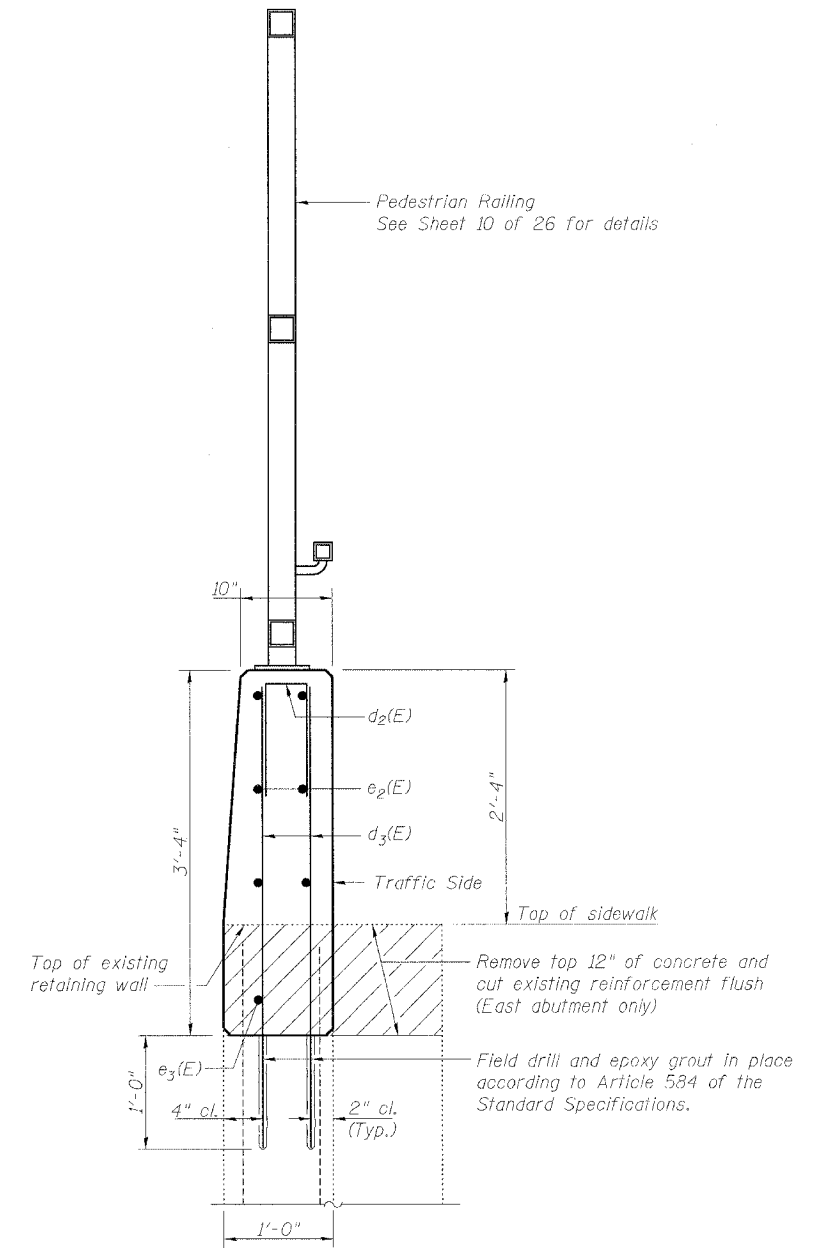

SECTION C-C

NOTES

Existing reinforcement bars extending into the removal area shall be blast cleaned to gray metal and straightened. Blast cleaning and straightening shall be included with the cost of Concrete Removal.

Existing reinforcement bars which have lost more than 25% of their original diameter shall be supplemented by new epoxy coated bars of the same diameter, spliced in place. Furnishing and placing supplemental epoxy coated reinforcement bars shall be included with the cost of Reinforcement Bars, Epoxy Coated.

Care shall be exercised by the contractor during and following removal operations to ensure that the existing rebar remaining in place are not damaged. All protruding rebar shall be cleaned, straightened, and properly positioned prior to concrete placement. Any rebar damaged during concrete removal shall be repaired or replaced using an approved Bar Splicer or Mechanical System. Cost included with Concrete Removal.

Reinforcement bars designated (E) shall be epoxy coated.

See Sheet 16 of 26 for Abutment Plan and Elevation.

See Sheet 15 of 26 for Bill of Material.

rjngroup
Excellence through Ownership

200 West Front Street
Wheaton, IL 60187

ILLINOIS DEPARTMENT OF TRANSPORTATION

ABUTMENT DETAILS - III
FOSTER AVE. OVER I-94 (EDENS EXPRESSWAY)
FAU RTE 1360 - SECTION 0101BR-2
COOK COUNTY
STATION 100+00
STRUCTURE NO. 016-0246

DATE: 4/30/2006

DRAWN BY BLB
CHECKED BY WJV