

F.A.P. RTE. 307	SECTION 2006-003 TS	COUNTY COOK	TOTAL SHEETS 63	SHEET NO. 45
STA. TO STA.		FED. ROAD DIST. NO. ILLINOIS FED. AID PROJECT		
CONTRACT NO. 60813				

CONTROLLER SEQUENCE

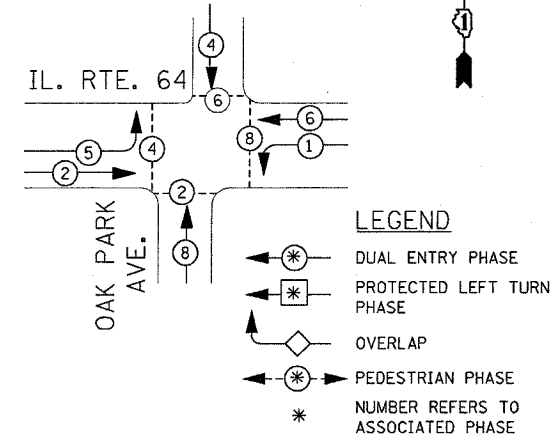

LEGEND
 * DUAL ENTRY PHASE
 * PROTECTED LEFT TURN PHASE
 OVERLAP
 * PEDESTRIAN PHASE
 * NUMBER REFERS TO ASSOCIATED PHASE

IL. RTE. 64

OAK PARK AVE.

THE END OF THE TRACER CABLE SHALL BE CONTINUOUS AND EXTEND INTO THE CONTROLLER CABINET.

CABLE PLAN LEGEND

	PROPOSED	EXISTING
CONTROLLER CABINET	[Symbol]	[Symbol]
RAILROAD CONTROL CABINET	[Symbol]	[Symbol]
SERVICE INSTALLATION, (P) POLE OR (G) GROUND MOUNT	[Symbol]	[Symbol]
TELEPHONE CONNECTION	[Symbol]	[Symbol]
GROUND ROD AT (C) CONTROLLER, (H) HANDHOLE, (P) POST, (M) MAST ARM, OR (S) SERVICE	[Symbol]	[Symbol]
FIBER OPTIC CABLE IN CONDUIT, NUMBER OF FIBERS AS NOTED	[Symbol]	[Symbol]
ELECTRIC CABLE IN CONDUIT, NO. 14, UNLESS OTHERWISE NOTED. NUMBER OF CONDUCTORS AS NOTED	[Symbol]	[Symbol]
GROUND CABLE IN CONDUIT NO. 6 COPPER (GREEN)	[Symbol]	[Symbol]
SIGNAL FACE WITH BACKPLATE. "P" INDICATES PROGRAMMED HEAD	[Symbol]	[Symbol]
12" (300mm) RED WITH 8" (200mm) YELLOW AND GREEN TRAFFIC SIGNAL FACE	[Symbol]	[Symbol]
12" (300mm) TRAFFIC SIGNAL SECTION	[Symbol]	[Symbol]
12" (300mm) PEDESTRIAN SIGNAL SECTION	[Symbol]	[Symbol]
ILLUMINATED SIGN "NO LEFT TURN"	[Symbol]	[Symbol]
ILLUMINATED SIGN "NO RIGHT TURN"	[Symbol]	[Symbol]
PUSHBUTTON DETECTOR	[Symbol]	[Symbol]
DETECTOR LOOP	[Symbol]	[Symbol]
PERFORMED DETECTOR LOOP	[Symbol]	[Symbol]
MICROWAVE VEHICLE SENSOR	[Symbol]	[Symbol]
VIDEO DETECTOR	[Symbol]	[Symbol]
CLOSED CIRCUIT TV	[Symbol]	[Symbol]
EMERGENCY VEHICLE SYSTEM DETECTOR	[Symbol]	[Symbol]
CONFIRMATION BEACON	[Symbol]	[Symbol]

THE END OF THE TRACER CABLE SHALL BE CONTINUOUS AND EXTEND INTO THE CONTROLLER CABINET.

* EXISTING 3 PAIR NO. 18 SHALL REMAIN IN ACT OF TRACER CABLE.

CABLE PLAN

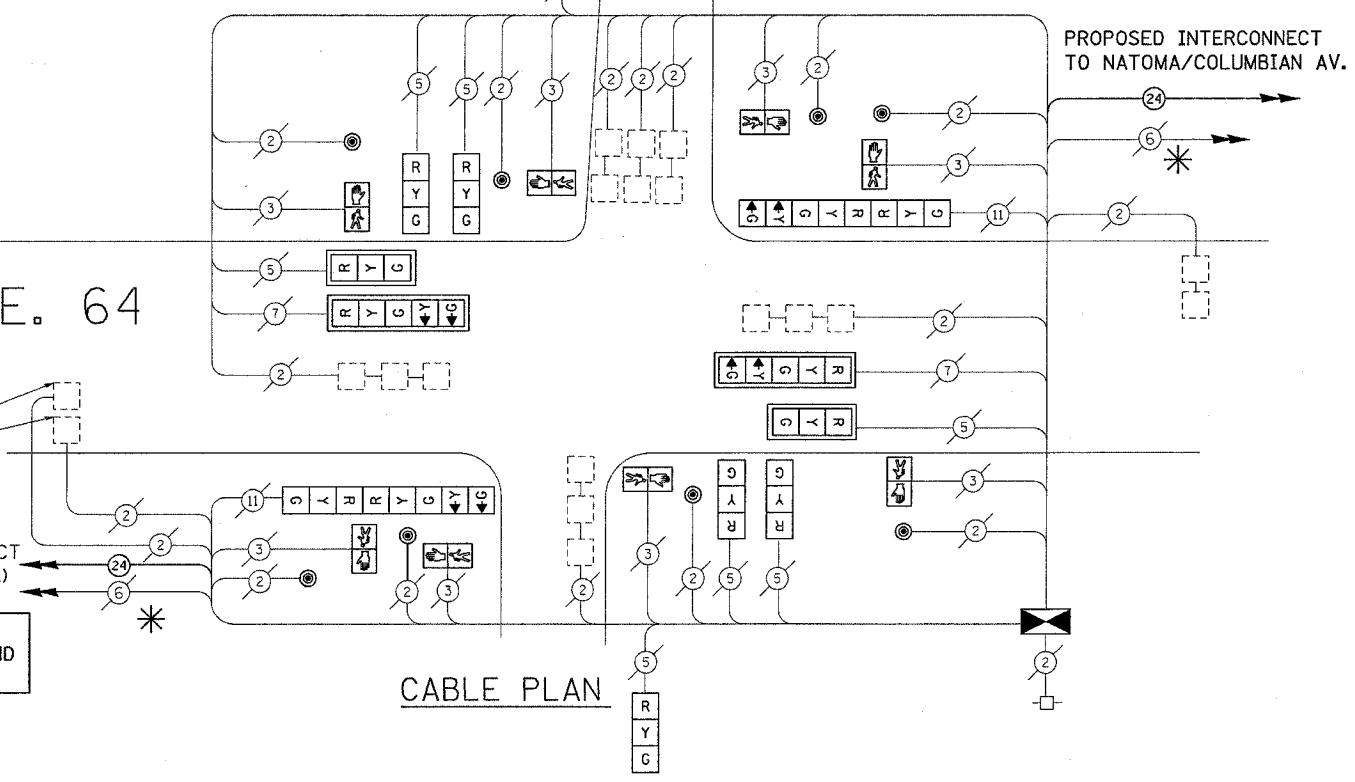

SCHEDULE OF QUANTITIES

ITEM	UNIT	QTY.
TRAFFIC CONTROL AND PROTECTION, STANDARD 701501	LSUM	.045
TRAFFIC CONTROL AND PROTECTION, STANDARD 701701	LSUM	.045
TRAFFIC CONTROL AND PROTECTION, STANDARD 701801	LSUM	.045
MAINTENANCE OF EXISTING TRAFFIC SIGNAL INSTALLATION	EACH	1
TRAFFIC SIGNAL POST, GALVANIZED STEEL 10 FT.	EACH	1
TRAFFIC SIGNAL POST, GALVANIZED STEEL 14 FT.	EACH	2
TRAFFIC SIGNAL POST, GALVANIZED STEEL 16 FT.	EACH	2
PEDESTRIAN PUSH-BUTTON	EACH	8
SIGNAL HEAD, LED, 1-FACE, 3-SECTION, BRACKET MOUNTED	EACH	6
SIGNAL HEAD, LED, 2-FACE, 1-3 SECTION, 1-5, SECTION BRACKET	EACH	2
SIGNAL HEAD, LED, 1-FACE, 3-SECTION, MAST ARM MNTD.	EACH	2
SIGNAL HEAD, LED, 1-FACE, 5-SECTION, MAST ARM MNTD.	EACH	2
PEDESTRIAN SIGNAL HEAD, LED, 1-FACE, BRACKET MOUNTED	EACH	8
FULL-ACTUATED CONTROLLER AND TYPE IV CABINET	EACH	1
TRANSCEIVER - FIBER OPTIC	EACH	1
INDUCTIVE LOOP DETECTOR	EACH	9
REMOVE EXISTING TRAFFIC SIGNAL EQUIPMENT	EACH	1
TRAFFIC SIGNAL BACKPLATE, LOUVERED ALUMINUM	EACH	4

I.D.O.T. TRAFFIC SIGNAL INSTALLATION ELECTRICAL SERVICE REQUIREMENTS					TOTAL WATTAGE
TYPE	NO. LAMPS	WATTAGE		% OPERATION	
SIGNAL (RED)	14	135	17	0.50	119.00
(YELLOW)	18	135	25	0.25	112.5
(GREEN)	16	135	15	0.25	60.00
ARROW	8	135	12	0.10	9.60
PED. SIGNAL		90	25	1.00	
CONTROLLER		100	100	1.00	
ILLUM. SIGN		84		0.05	
FLASHER				0.50	
ENERGY COSTS TO:					TOTAL = 301.10

ILLINOIS DEPARTMENT OF TRANSPORTATION
 201 WEST CENTER COURT
 SCHAUMBURG, ILLINOIS 60196-1096
 ENERGY SUPPLY CONTACT: LARRY D. SHANK
 PHONE: (847) 291-3214
 COMPANY: COMMONWEALTH EDISON

FOUNDATION (DEPTH)	FT. (m)	CABLE SLACK	FT. (m)	VERTICAL	FT. (m)
TYPE A - POST	4 (1.2)	HANDHOLE	6.5 (2.0)	ALL FOUNDATIONS	3.5 (1.0)
D - CONTROLLER	4 (1.2)	DOUBLE HANDHOLE	13 (4.0)	MAST ARM (L) POLE	20' H-2' (6m H-0.6m)
E - M. ARM POLE		SIGNAL POST	2 (1.0)		
24" (600mm)	10 (3.0)	CONTROLLER CAB.	1 (0.5)	BRACKET MOUNTED	13 (4.0)
30" (750mm)	15 (4.6)	FIBER OPTIC	13 (4.0)	PED. PUSHBUTTON	4 (1.2)
		ELECTRIC SERVICE	1 (0.5)	ELECTRIC SERVICE	13.5 (4.1)
		GROUND CABLE	1 (0.5)	SERVICE TO GROUND	13.5 (4.1)
				POST MOUNTED	6 (1.8)

REVISIONS		ILLINOIS DEPARTMENT OF TRANSPORTATION
NAME	DATE	
		PROPOSED CABLE PLAN FOR ILL. RTE. 64 (NORTH AVE.) AT OAK PARK AVE. SCALE: NONE DATE 6/23/2006 DRAWN BY BCK DESIGNED BY BCK CHECKED BY DAD