

STATE OF ILLINOIS  
DEPARTMENT OF TRANSPORTATION

ROUTE NO.	SECTION	COUNTY	TOTAL SHEETS	SHEET NO.	SHEET NO. 6 10 SHEETS
F.A.P. 817	8BR-2, 8BR-3	WASHINGTON	52	25	
FED. ROAD DIST. NO. 7	ILLINOIS	FED. AID PROJECT			

Contract #76946

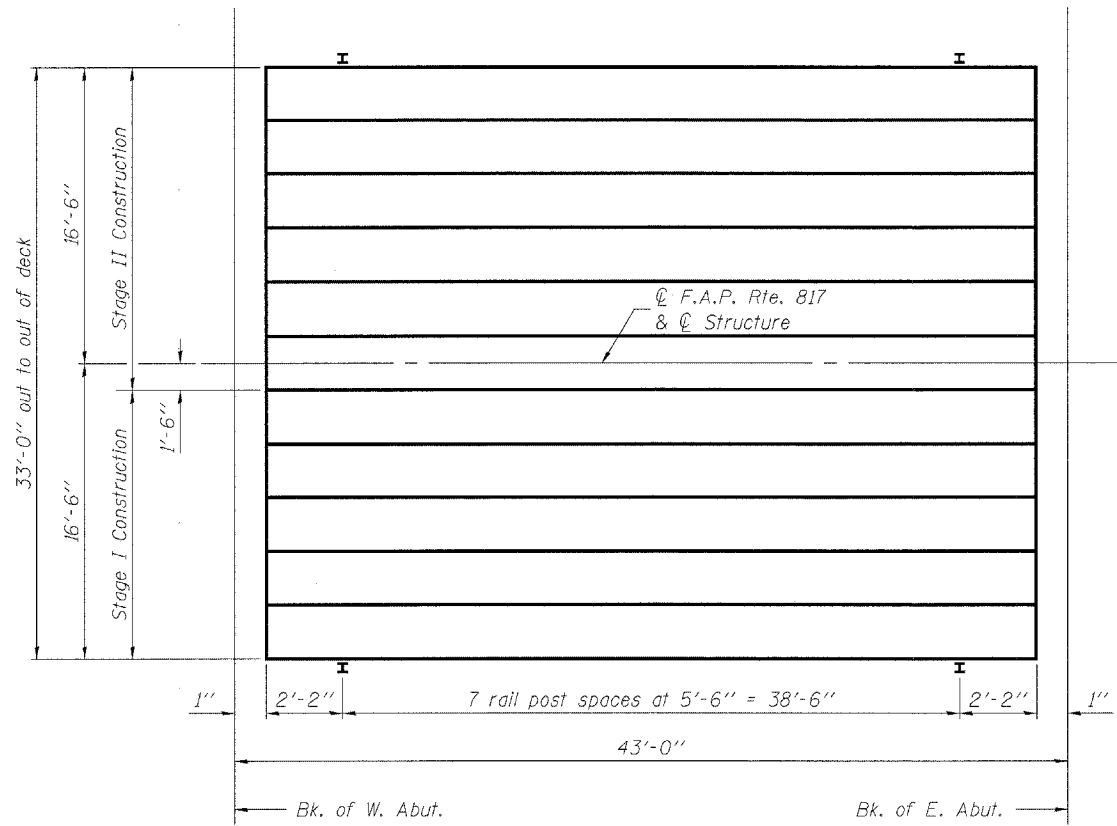

**PLAN**

Notes:  
Rail spacing the same on both sides of the bridge.  
See sheet 5 of 10 for end of bridge rail location.

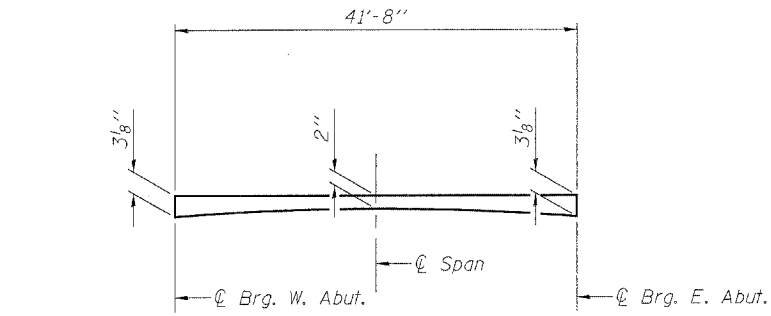

**BITUMINOUS CONCRETE SURFACE COURSE PROFILE**

(Bituminous concrete surface course along edge of beams)

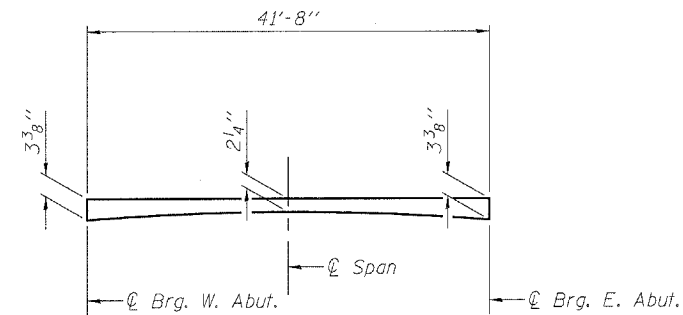

**BITUMINOUS CONCRETE SURFACE COURSE PROFILE**

(Bituminous concrete surface course along roadway)

Note:  
Bituminous Concrete Surface Course Profile dimensions include 1/2" for waterproofing membrane thickness.

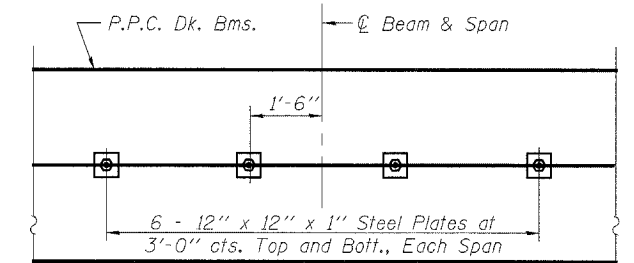

**PLAN**

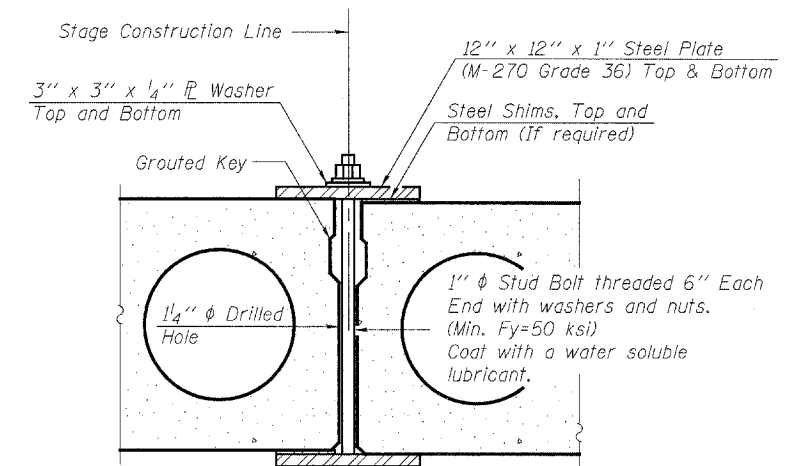

**SECTION**

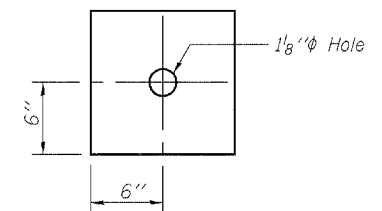

**CLAMPING PLATE**

**SHEAR KEY CLAMPING DETAILS AT STAGE CONST. JT.**

See Special Provisions for Stage Construction of Precast Prestressed Concrete Deck Beams.  
Cost included with "Precast Prestressed Concrete Deck Beams".  
See Stage Construction Details for traffic lanes.

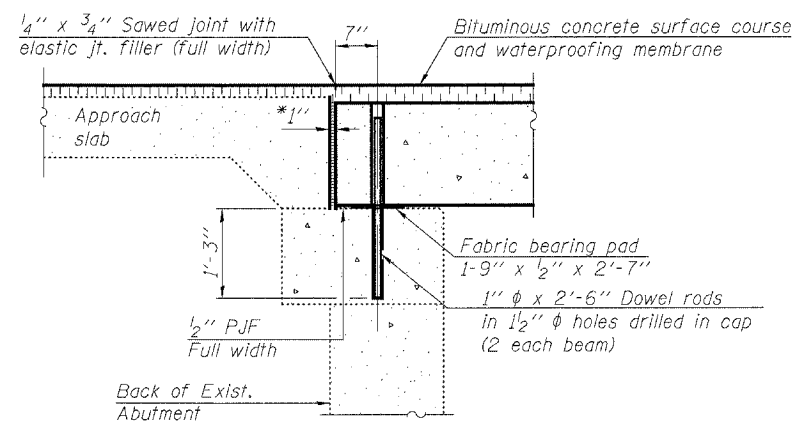

**SECTION THRU ABUTMENT**

\* 1" Jt. shall be filled with non-shrink grout. 1" dimension may vary to accommodate tolerance in beam lengths.

Notes:  
After beams have been erected, holes shall be drilled into substructure and anchor dowels placed. Dowel holes shall be filled with non-shrink grout to top of beam and allowed to cure min. 24 hrs. prior to grouting the shear keys.  
All horizontal dimensions are at right angles to beam ends.  
See sheet 7 of 10 for bearing pad details.

DESIGNED	EML
CHECKED	NJM
DRAWN	EML
CHECKED	NJM

**HORNER & SHIFRIN, INC.**  
ENGINEERS ■ ARCHITECTS ■ PLANNERS

**SUPERSTRUCTURE DETAILS**  
**F.A.P. ROUTE 817 - SECTION 8BR-2**  
**WASHINGTON COUNTY**  
**STATION 25+18.00**  
**STRUCTURE NO. 095-0010**