

F.A.P. RTE.	SECTION	COUNTY	TOTAL SHEETS	SHEET NO.
817	8BR-2, 8BR-3	WASHINGTON	52	1

STATE OF ILLINOIS
DEPARTMENT OF TRANSPORTATION
DIVISION OF HIGHWAYS

**PROPOSED
HIGHWAY PLANS**

FAP ROUTE 817 (IL 15)
SECTION 8BR-2, 8BR-3
PROJECT: **BHF-0817 (006)**
SUPERSTRUCTURE REPLACEMENT
WASHINGTON COUNTY

C-98-112-05

FOR INDEX OF SHEETS, SEE SHEET NO. 2

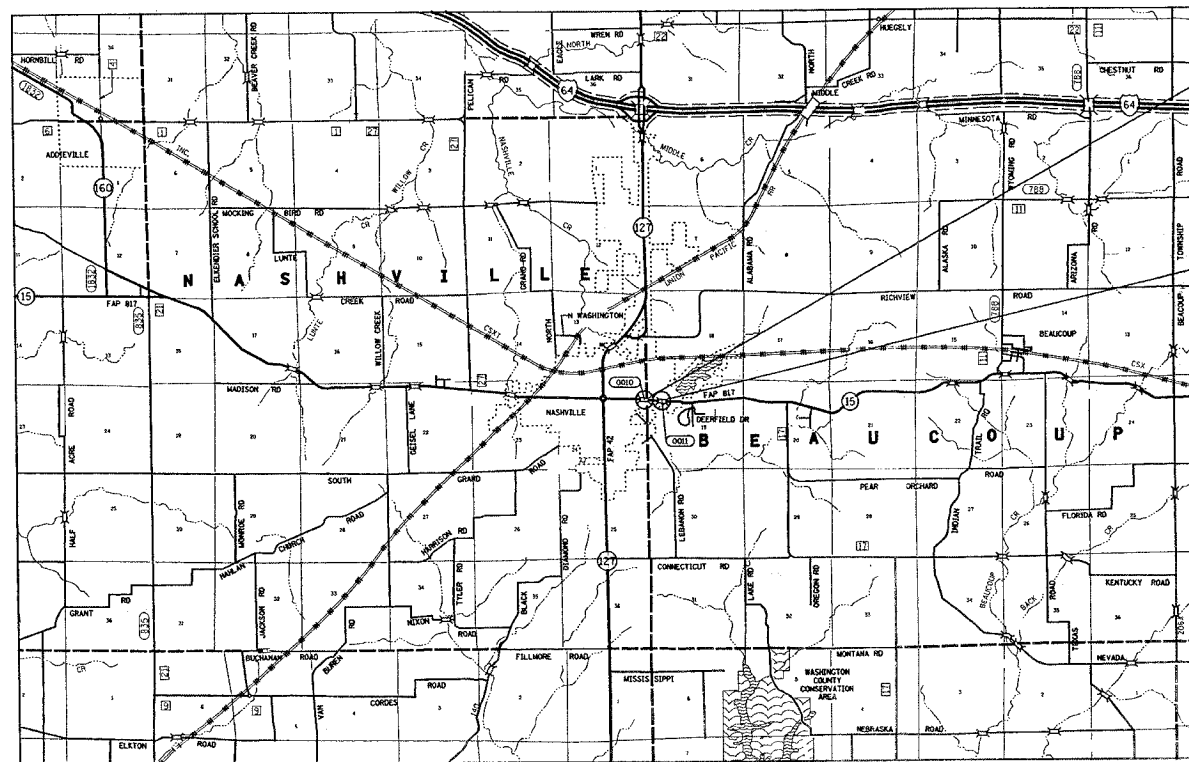

REMOVE AND REPLACE SINGLE SPAN
PPC DECK BEAM SUPERSTRUCTURE
IN KIND OVER NASHVILLE CREEK
BEGIN STA 22+83
END STA 27+00
SN 095-0010

REMOVE AND REPLACE SINGLE SPAN
PPC DECK BEAM SUPERSTRUCTURE
IN KIND OVER NASHVILLE CREEK
BEGIN STA 34+50
END STA 38+00
SN 095-0011

MICROFILMED _____
REEL NUMBER _____
AWARDED _____
RESIDENT ENGINEER _____
AS BUILT CHANGES WERE MADE
ON THE FOLLOWING SHEETS

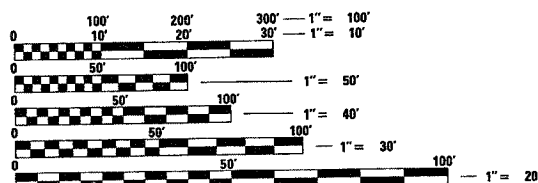

FULL SIZE PLANS HAVE BEEN PREPARED USING STANDARD
ENGINEERING SCALES. REDUCED SIZED PLANS WILL NOT
CONFORM TO STANDARD SCALES. IN MAKING MEASUREMENTS
ON REDUCED PLANS, THE ABOVE SCALES MAY BE USED.

J.U.L.I.E.
JOINT UTILITY LOCATION INFORMATION FOR EXCAVATION
1-800-892-0123

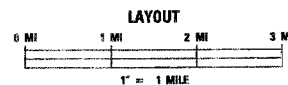

DESIGN DESIGNATION	ADT = 3600 (2005)
NA	ADT = 4500 (2026)
	SU = 3.3%
	MU = 2.2%

SN 095-0010	SN 095-0011
LAT 38.34336	LAT 38.34307
LONG 89.37180	LONG 89.36814

DECK LENGTH 0.01 MI
DECK LENGTH 0.01 MI

STATE OF ILLINOIS
DEPARTMENT OF TRANSPORTATION
DIVISION OF HIGHWAYS

SUBMITTED June 28, 2006
May O'Hara
DEPUTY DIRECTOR OF HIGHWAYS
REGION FIVE ENGINEER

August 18, 2006
Mike Nire
ENGINEER OF DESIGN AND ENVIRONMENT

August 18, 2006
Milton R. Seo, P.E.
DIRECTOR, DIVISION OF HIGHWAYS

**PRINTED BY THE AUTHORITY
OF THE STATE OF ILLINOIS**

PROJECT ENGINEER: PATTI LeBEAU (618) 346-3179
SQUAD CONTACT: ARTHUR MUEHLFELD (618) 346-3209

CONTRACT NO. 76946

F.A.P. RTE.	SECTION	COUNTY	TOTAL SHEETS	SHEET NO.
817	8BR-2, 8BR-3	WASHINGTON	52	2
STA.		TO STA.		
FED. ROAD DIST. NO.	ILLINOIS	FED. AID PROJECT		

INDEX OF SHEETS

- 1 COVER SHEET
- 2 INDEX OF SHEETS, HIGHWAY STANDARDS, GENERAL NOTES & COMMITMENTS
- 3-5 SUMMARY OF QUANTITIES
- 6 TYPICAL SECTIONS
- 7 TIE POINTS & BENCHMARKS
- 8 WIDE LOAD SIGNING

SN 095-0010 SECTION 8BR-2

- 9 SCHEDULES
- 10 REMOVAL PLAN
- 11 PLAN SHEET
- 12-14 STAGE CONSTRUCTION
- 15 EROSION CONTROL SHEET
- 16-17 PLAT OF HIGHWAYS
- 18 MISCELLANEOUS DETAILS
- 19 PAVEMENT MARKING SHEET
- 20-29 BRIDGE PLANS
- 30-32 CROSS SECTIONS

SN 095-0011 SECTION 8BR-3

- 33 SCHEDULES
- 34 REMOVAL PLAN
- 35 PLAN SHEET
- 36-38 STAGE CONSTRUCTION
- 39 EROSION CONTROL SHEET
- 40 PAVEMENT MARKING SHEET
- 41-49 BRIDGE PLANS
- 50-52 CROSS SECTIONS

HIGHWAY STANDARDS

000001-04	631032-02	701321-08
280001-02	635011-01	701326-02
515001-02	666001	702001-06
630001-06	701011-01	704001-02
630301-03	701301-02	780001-01
631006-03	701306-01	781001-02
631011-02	701311-02	

GENERAL NOTES:

1. THE STANDARDS AND REVISION NUMBERS SHALL APPLY TO THIS PROJECT.
2. THE CONTRACTOR SHALL VERIFY ALL DIMENSIONS AND CONDITIONS IN THE FIELD PRIOR TO CONSTRUCTION AND ORDERING MATERIALS.
3. ILLINOIS STATE LAW REQUIRES A 48-HOUR NOTICE BE GIVEN TO UTILITIES WITHIN THE PROJECT AREA BEFORE DIGGING BY CALLING J.U.L.I.E. AND BY NOTIFYING NON-J.U.L.I.E. MEMBERS INDIVIDUALLY. AGENCIES KNOWN TO HAVE FACILITIES WITHIN THE PROJECT AREA ARE AS FOLLOWS:
 - AMEREN IP (ELECTRIC)
 - CHARTER COMMUNICATIONS, INC.
 - CITY OF NASHVILLE (GAS, WATER & SEWER)
 - AT&T (COMMUNICATIONS)
 - WASHINGTON COUNTY WATER CO.
 MEMBERS OF J.U.L.I.E. (800) 892-0123 ARE INDICATED BY *. NON-MEMBERS MUST BE NOTIFIED INDIVIDUALLY.
4. THE CONTRACTOR SHALL PROVIDE TWO SIGNAL HEADS (EACH) FOR THE THREE ENTRANCES LOCATED WITHIN THE STAGE CONSTRUCTION OF SN 095-0010 (STA 23+24.27 RT, STA 24+64.35 LT AND STA 26+28.65 LT.) THE SIGNALS, DETECTOR LOOPS, AND THE NUMBER OF TURNS OF WIRE IN THE LOOPS SHALL BE AS DETERMINED BY THE ENGINEER.
5. THE CONTRACTOR SHALL FURNISH AND INSTALL WOOD SIGN SUPPORTS IN ACCORDANCE WITH SECTION 730 OF THE STANDARD SPECIFICATIONS; HOWEVER, INSTALLATION BY METHOD 'A' (ARTICLE 730.04(c)) SHALL BE THE ONLY METHOD PERMITTED.
6. "ROAD CONSTRUCTION AHEAD" SIGNS SHALL BE PLACED AT THE BEGINNING AND ENDING OF THE PROJECT AND WILL BE INCLUDED IN THE TRAFFIC CONTROL PAY ITEMS. ALL CONSTRUCTION SIGNS SHALL BE FLOURESCENT ORANGE.
7. ALL SIGNS THAT INTERFERE WITH CONSTRUCTION OPERATIONS SHALL BE REMOVED, STORED AND RE-ERECTED ACCORDING TO ARTICLE 107.25 OF THE STANDARD SPECIFICATIONS.
8. ANY DAMAGE TO SIGNS CAUSED BY CONSTRUCTION ACTIVITIES SHALL BE REPLACED AT THE CONTRACTOR'S EXPENSE.
9. ALL SAW CUTTING FOR REMOVAL ITEMS SHALL BE FULL DEPTH AND SHALL BE INCLUDED IN THE COST OF THE REMOVAL ITEM.
10. NO TRENCHES OR OPEN PITS WILL BE PERMITTED ADJACENT TO A TRAFFIC LANE DURING NON-WORKING HOURS. ALL WIDENING TRENCHES SHALL BE BACKFILLED DURING THE SAME WORKING DAY IT WAS EXCAVATED.
11. THE COST FOR GRADING AND SHAPING ALONG THE PROPOSED WIDENING SHALL BE INCLUDED IN THE COST OF "EARTH EXCAVATION (WIDENING)".
12. THE TRAFFIC CONTROL MEASURES SHOWN ON PLANS FOR STAGE I AND II SHALL SUPPLEMENT AND BE IN ACCORDANCE WITH TRAFFIC CONTROL STANDARD 701321.
13. THE COST OF "BARRICADES, TYPE III" USED DURING STAGE CONSTRUCTION SHALL BE INCLUDED IN THE COST OF "TRAFFIC CONTROL AND PROTECTION, STANDARD 701321 (SPECIAL)".
14. A QUANTITY OF 737.5 FEET OF "TEMPORARY PAVEMENT MARKING - LINE 6 INCHES" WHITE HAS BEEN INCLUDED IN THE PLANS FOR PAINTING THE BOTTOM 6" OF THE TEMPORARY CONCRETE BARRIER.
15. THE BARRIER UNIT AT EACH END OF THE TRAFFIC CONTROL INSTALLATION SHALL BE SECURED TO THE PAVEMENT OR SHOULDER USING ALL SIX ANCHORING PINS FOR F-SHAPE BARRIER OR ALL SIX DOWEL BARS FOR NEW JERSEY SHAPE BARRIER.
16. THE TEMPORARY CONCRETE BARRIER (STATE OWNED) IS LOCATED AT THE CARLYLE MAINTENANCE YARD, CONTACT JASON ROECKENHAUS AT (618) 594-3001 PRIOR TO PICK UP. THE CONTRACTOR SHALL PICK UP THE BARRIER AND RETURN THE BARRIER TO THE SAME LOCATION UPON COMPLETION OF THE PROJECT. ANY DAMAGED BARRIER WILL NOT HAVE TO BE REPLACED. THE CONTRACTOR SHALL DISPOSE OF DAMAGED CONCRETE BARRIER IN AN APPROVED DUMP SITE. THE CONNECTOR PINS SHALL BE FURNISHED BY THE CONTRACTOR AND THE COST SHALL BE INCLUDED WITH THE COST OF "TEMPORARY CONCRETE BARRIER (STATE OWNED)".

EROSION CONTROL PLAN

ALL EROSION CONTROL PRODUCTS FURNISHED SHALL BE SPECIFICALLY RECOMMENDED BY THE MANUFACTURER FOR THE USE SPECIFIED IN THE EROSION CONTROL PLAN. PRIOR TO THE APPROVAL AND USE OF THE PRODUCT, THE CONTRACTOR SHALL SUBMIT TO THE ENGINEER A NOTARIZED CERTIFICATION BY THE PRODUCER STATING THE INTENDED USE OF THE PRODUCT AND THAT THE PHYSICAL PROPERTIES REQUIRED FOR THIS APPLICATION ARE MET OR EXCEEDED. THE CONTRACTOR SHALL PROVIDE MANUFACTURER RECOMMENDED INSTALLATION PROCEDURES TO FACILITATE THE ENGINEER IN CONSTRUCTION INSPECTION.

STRAW BALES, HAY BALES, PERIMETER EROSION BARRIER AND SILT FENCES WILL NOT BE PERMITTED FOR TEMPORARY OR PERMANENT DITCH CHECKS. DITCH CHECKS SHALL BE COMPOSED OF AGGREGATE, SILT PANELS, ROLLED EXCELSIOR, URETHANE/GEOTEXTILE (SILT WEDGES), EARTH MEDIAN AND/OR OTHER MATERIAL APPROVED BY THE EROSION AND SEDIMENT CONTROL COORDINATOR.

TEMPORARY DITCH CHECKS, GEOTEXTILES, ROLLED EXCELSIOR, SILT WEDGES, PANELS SHALL BE LOCATED AT EVERY 1.5 FT FALL/RISE IN DITCH GRADE.

TEMPORARY DITCH CHECKS, AGGREGATE USES GRADING NO. 3 -- REMOVE AT END OF CONSTRUCTION.

TEMPORARY SEEDING AND MULCH SHALL BE COMPLETED ON A WEEKLY BASIS ON EXPOSED GROUND AND SHALL BE IN ACCORDANCE WITH SECTION 280 OF THE STANDARD SPECIFICATIONS. TEMPORARY EROSION CONTROL SEEDING SHALL BE APPLIED AT A RATE OF 100 LBS/ACRE. THIS WORK SHALL BE PAID FOR AS "TEMPORARY EROSION CONTROL SEEDING", WHICH WILL INCLUDE MULCH. FOR CALCULATION PURPOSES, THREE APPLICATIONS OF TEMPORARY SEEDING WAS ASSUMED.

EARTH STOCKPILES SHALL BE TEMPORARILY SEEDED IF THEY ARE TO REMAIN UNUSED FOR MORE THAN FOURTEEN DAYS.

FINAL SEEDING SHALL BE PERFORMED AS SOON AS POSSIBLE WITH CLASS 2 SEEDING.

COMMITMENTS

NONE

PERTINENT INFORMATION

TWO ENTRANCES WILL BE AFFECTED DURING THIS PROJECT. THE PROPERTY OWNERS SHALL BE NOTIFIED 24 HOURS IN ADVANCE OF ANY WORK AFFECTING THEIR ENTRANCES.

PRIVATE ENTRANCE AT STA 24+64.35 LT:
"THE LATE" EDWARD & MARY BERNREUTER
1117 E. ST. LOUIS STREET
NASHVILLE, IL 62263
(618) 327-3334
CONTACT PERSON:
CAROL LUTZ (DAUGHTER)
(618)327-3955

COMMERCIAL ENTRANCE AT STA 23+24.27 RT:
LEO BARCZWESKI
22925 RICHVIEW ROAD
RICHVIEW, IL 62877
(618) 493-7742
SHEILA EATON (618) 443-2162
PAUL BARCZWESKI (618) 327-9187

PRIVATE ENTRANCE AT STA 25+82.12 LT WILL BE CLOSED DURING CONSTRUCTION OF SN 095-0010. THE BARRICADES SHALL BE PLACED ALONG THE PROPOSED WIDENING TO MAXIMIZE THE PARKING AREA FOR THE PROPERTY OWNER.
PRIVATE ENTRANCE AT STA 26+28.65 LT SHALL REMAIN OPEN AT ALL TIMES.
IF TEMPORARY CLOSURE IS NEEDED, THE PROPERTY OWNER SHALL BE NOTIFIED.

EDWARD & DOROTHY HOFFMAN
1175 E. ST. LOUIS STREET
NASHVILLE, IL 62263
HM: (618) 327-4165
WK: (618) 327-4401

REVISIONS	
NAME	DATE

ILLINOIS DEPARTMENT OF TRANSPORTATION
INDEX OF SHEETS, HIGHWAY STANDARDS, GENERAL NOTES AND COMMITMENTS
FAP ROUTE 817
SECTION 8BR-2, 8BR-3
WASHINGTON COUNTY
SN 095-0010 & 0011

F.A.P. RTE.	SECTION	COUNTY	TOTAL SHEETS	SHEET NO.
817	8BR-2, 8BR-3	WASHINGTON	52	3
STA.		TO STA.		
FED. ROAD DIST. NO.		ILLINOIS FED. AID PROJECT		

ILLINOIS DEPARTMENT OF TRANSPORTATION

SUMMARY OF QUANTITIES

SUMMARY OF QUANTITIES			CONSTRUCTION TYPE CODE				
CODE NO	ITEM	UNIT	80% FED 20% STATE TOTAL QUANTITIES	SN 095-0010 SEC 8BR-2		SN 095-0011 SEC 8BR-3	
				X080-2A	SFTY-3N	X080-2A	SFTY-3N
20200100	EARTH EXCAVATION	CU YD	35	35			
20200500	EARTH EXCAVATION (WIDENING)	CU YD	70	40		30	
20400800	FURNISHED EXCAVATION	CU YD	290	55		235	
25000200	SEEDING, CLASS 2	ACRE	0.5	0.25		0.25	
25000400	NITROGEN FERTILIZER NUTRIENT	POUND	46	23		23	
25000500	PHOSPHORUS FERTILIZER NUTRIENT	POUND	46	23		23	
25000600	POTASSIUM FERTILIZER NUTRIENT	POUND	46	23		23	
25100115	MULCH, METHOD 2	ACRE	0.5	0.25		0.25	
25100630	EROSION CONTROL BLANKET	SQ YD	807	240		567	
28000250	TEMPORARY EROSION CONTROL SEEDING	POUND	150	75		75	
28000300	TEMPORARY DITCH CHECKS	EACH	2	2			
28000400	PERIMETER EROSION BARRIER	FOOT	1090	255		835	
28100105	STONE RIPRAP, CLASS A3	SQ YD	129	84		45	
28200200	FILTER FABRIC	SQ YD	129	84		45	
35102000	AGGREGATE BASE COURSE, TYPE B 8"	SQ YD	37	37			
40200500	AGGREGATE SURFACE COURSE, TYPE A 6"	SQ YD	80	80			
40600200	BITUMINOUS MATERIALS (PRIME COAT)	TON	0.7	0.4		0.3	
40600300	AGGREGATE (PRIME COAT)	TON	4	2		2	
40600990	TEMPORARY RAMP	SQ YD	72	36		36	
40800040	INCIDENTAL BITUMINOUS SURFACING	TON	6	6			
42001400	BRIDGE APPROACH PAVEMENT (SPECIAL)	SQ YD	132	66		66	
44000007	BITUMINOUS SURFACE REMOVAL 2"	SQ YD	1926	1038		888	
44000200	DRIVEWAY PAVEMENT REMOVAL	SQ YD	99	99			
50101500	REMOVAL OF EXISTING SUPERSTRUCTURES	EACH	2	1		1	
50102400	CONCRETE REMOVAL	CU YD	19.3	10.1		9.2	
50105220	PIPE CULVERT REMOVAL	FOOT	43	43			
50300225	CONCRETE STRUCTURES	CU YD	0.9	0.9			
50400305	PRECAST PRESTRESSED CONCRETE DECK BEAMS (17" DEPTH)	SQ FT	2465	1414		1051	
50800205	REINFORCEMENT BARS, EPOXY COATED	POUND	40	40			
50901005	STEEL BRIDGE RAIL, TYPE SM	FOOT	252	126		126	
51500100	NAME PLATES	EACH	2	1		1	
54002020	EXPANSION BOLTS 3/4 INCH	EACH	224	112		112	
54200223	PIPE CULVERTS, CLASS D, TYPE 1 18"	FOOT	41	41			
58100200	WATERPROOFING MEMBRANE SYSTEM	SQ YD	275	158		117	
58300100	PORTLAND CEMENT MORTAR FAIRING COURSE	FOOT	746	428		318	
* 63000000	STEEL PLATE BEAM GUARD RAIL, TYPE A	FOOT	487.5	125		362.5	

PLOT DATE = 8/27/82
 PLOT NAME = 817L1
 PLOT SCALE = 1"=50'
 REFERENCE = 817L1

* SPECIALTY ITEMS

F.A.P. RTE.	SECTION	COUNTY	TOTAL SHEETS	SHEET NO.
817	8BR-2, 8BR-3	WASHINGTON	52	4
STA.	TO STA.			
FED. ROAD DIST. NO.	ILLINOIS	FED. AID PROJECT		

ILLINOIS DEPARTMENT OF TRANSPORTATION

SUMMARY OF QUANTITIES

SUMMARY OF QUANTITIES			80% FED 20% STATE TOTAL QUANTITIES	CONSTRUCTION TYPE CODE			
CODE NO	ITEM	UNIT		SN 095-0010 SEC 8BR-2		SN 095-0011 SEC 8BR-3	
				X080-2A	SFTY-3N	X080-2A	SFTY-3N
* 63100041	TRAFFIC BARRIER TERMINAL, TYPE 1B	EACH	1			1	
* 63100045	TRAFFIC BARRIER TERMINAL, TYPE 2	EACH	2	2			
* 63100087	TRAFFIC BARRIER TERMINAL, TYPE 6A	EACH	8	4		4	
* 63100167	TRAFFIC BARRIER TERMINAL TYPE 1, SPECIAL (TANGENT)	EACH	6	2		4	
63200310	GUARDRAIL REMOVAL	FOOT	662.5	225		437.5	
63301210	REMOVE AND RE-ERECT STEEL PLATE BEAM GUARD RAIL, TYPE A	FOOT	37.5			37.5	
66600105	FURNISHING AND ERECTING RIGHT-OF-WAY MARKERS	EACH	7	7			
67000400	ENGINEER'S FIELD OFFICE, TYPE A	CAL MO	14	7		7	
67100100	MOBILIZATION	L SUM	1	0.5		0.5	
70100460	TRAFFIC CONTROL AND PROTECTION, STANDARD 701306	L SUM	1	0.5		0.5	
70100500	TRAFFIC CONTROL AND PROTECTION, STANDARD 701326	L SUM	1	0.5		0.5	
70101205	TRAFFIC CONTROL AND PROTECTION, STANDARD 701321 (SPECIAL)	EACH	2	1		1	
70106600	TEMPORARY BRIDGE TRAFFIC SIGNALS (STATE FURNISHED CONTROLLER)	EACH	2	1		1	
70106700	TEMPORARY RUMBLE STRIP	EACH	6	3		3	
70300100	SHORT-TERM PAVEMENT MARKING	FOOT	108	52		56	
70300220	TEMPORARY PAVEMENT MARKING - LINE 4"	FOOT	4248	1848		2400	
70300240	TEMPORARY PAVEMENT MARKING - LINE 6"	FOOT	737.5	287.5		450	
70301000	WORK ZONE PAVEMENT MARKING REMOVAL	SQ FT	1452	633		819	
70400500	TEMPORARY CONCRETE BARRIER (STATE OWNED)	FOOT	425	200		225	
70400600	RELOCATE TEMPORARY CONCRETE BARRIER (STATE OWNED)	FOOT	312.5	87.5		225	
70500100	TEMPORARY STEEL PLATE BEAM GUARD RAIL, TYPE A	FOOT	37.5			37.5	
* 78000200	THERMOPLASTIC PAVEMENT MARKING - LINE 4"	FOOT	4248	1848		2400	
* 78100100	RAISED REFLECTIVE PAVEMENT MARKER	EACH	9	5		4	
* 78100105	RAISED REFLECTIVE PAVEMENT MARKER (BRIDGE)	EACH	1			1	
* 78100300	REPLACEMENT REFLECTOR	EACH	4	2		2	
* 78200410	GUARDRAIL MARKERS, TYPE A	EACH	15	6		9	
* 78201000	TERMINAL MARKER - DIRECT APPLIED	EACH	5	2		3	
78300100	PAVEMENT MARKING REMOVAL	SQ FT	1416	616		800	
78300200	RAISED REFLECTIVE PAVEMENT MARKER REMOVAL	EACH	14	7		7	

* DATE *
 * FILE NAME *
 * PLOT SCALE *
 * REFERENCE *

* SPECIALTY ITEMS

SUMMARY OF QUANTITIES

F.A.P. RTE.	SECTION	COUNTY	TOTAL SHEETS	SHEET NO.
817	8BR-2, 8BR-3	WASHINGTON	52	5
STA.		TO STA.		
FED. ROAD DIST. NO.	ILLINOIS	FED. AID PROJECT		

SUMMARY OF QUANTITIES			80% FED 20% STATE TOTAL QUANTITIES	CONSTRUCTION TYPE CODE			
CODE NO	ITEM	UNIT		SN 095-0010 SEC 8BR-2		SN 095-0011 SEC 8BR-3	
				X080-2A	SFTY-3N	X080-2A	SFTY-3N
X0324744	REMOVAL OF EXISTING PRECAST CONCRETE UNITS	SQ FT	598	299		299	
X0325305	STRUCTURAL REPAIR OF CONCRETE (DEPTH EQUAL TO OR LESS THAN 5 INCHES)	SQ FT	20.5	14		6.5	
X0325445	RIGHT-OF-WAY AND PROPERTY CORNERS	EACH	2	2			
X3560130	BITUMINOUS CONCRETE BASE COURSE WIDENING, SUPERPAVE 9 INCH	SQ YD	544	297		247	
X4066416	BITUMINOUS CONCRETE SURFACE COURSE, SUPERPAVE, MIX "C", N70	TON	255	139		116	
X6330103	REMOVE AND RE-ERECT TRAFFIC BARRIER TERMINAL, TYPE 1 SPECIAL, TANGENT	EACH	1			1	
X7200200	WIDE LOAD SIGNING	L SUM	1	0.5		0.5	
Z0030250	IMPACT ATTENUATORS, TEMPORARY (NON-REDIRECTIVE), TEST LEVEL 3	EACH	4		2		2
Z0030260	IMPACT ATTENUATORS, TEMPORARY (FULLY REDIRECTIVE, NARROW), TEST LEVEL 3	EACH	1		1		
Z0030350	IMPACT ATTENUATORS, RELOCATE (NON-REDIRECTIVE), TEST LEVEL 3	EACH	3		1		2

F.A.P. RTE.	SECTION	COUNTY	TOTAL SHEETS	SHEET NO.
817	8BR-2, 8BR-3	WASHINGTON	52	6
STA.		TO STA.		
FED. ROAD DIST. NO.		ILLINOIS FED. AID PROJECT		

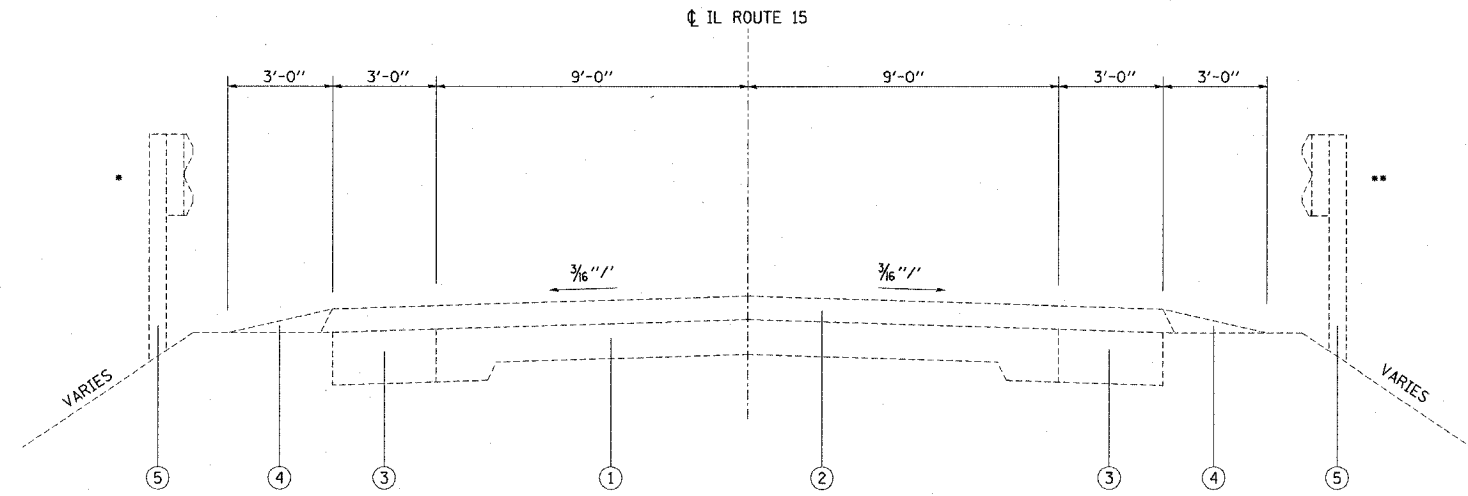

• 0010- STA 24+79 TO STA 25+57
 0011- STA 34+93 TO STA 37+45

•• 0010- STA 23+79 TO STA 26+56
 0011- STA 34+84 TO STA 37+46

EXISTING TYPICAL SECTION

0010- STA 22+83 TO STA 24+76.58
 STA 25+59.42 TO STA 27+00
 0011- STA 34+50 TO STA 35+76.79
 STA 36+48.63 TO STA 38+00

LEGEND

- ① EXISTING PCC PAVEMENT - 9'-6"-9"
- ② EXISTING RESURFACING
- ③ EXISTING PCC BASE COURSE WIDENING - 9"
- ④ EXISTING AGGREGATE SHOULDER
- ⑤ EXISTING GUARDRAIL
- ⑥ PROPOSED BITUMINOUS SURFACE REMOVAL - 2"
- ⑦ PROPOSED BITUMINOUS CONCRETE SURFACE COURSE, SUPERPAVE - 2"
- ⑧ PROPOSED BITUMINOUS BASE COURSE WIDENING, SUPERPAVE - 9"
- ⑨ PROPOSED GUARDRAIL
- ⑩ PROPOSED BITUMINOUS MATERIALS PRIME COAT
- ⑪ PROPOSED AGGREGATE (PRIME COAT)

MIXTURE USE	SURFACE	BINDER / BSE CSE
AC/PG	PG 64-22	PG 64-22
RAP % (MAX)	10%	15%
DESIGN AIR VOIDS	4.0% @ Ndes=70	4.0% @ Ndes=70
MIX COMPOSITION (GRADATION MIXTURE)		
FRICTION AGG	MIXTURE "C"	MIXTURE "B"

PLAN QUANTITIES FOR BITUMINOUS CONCRETE SURFACE COURSE ITEMS ARE CALCULATED USING A UNIT WEIGHT OF 112 LB/SQ YD/IN (59.8 KG/SQ M/25 MM THICKNESS).

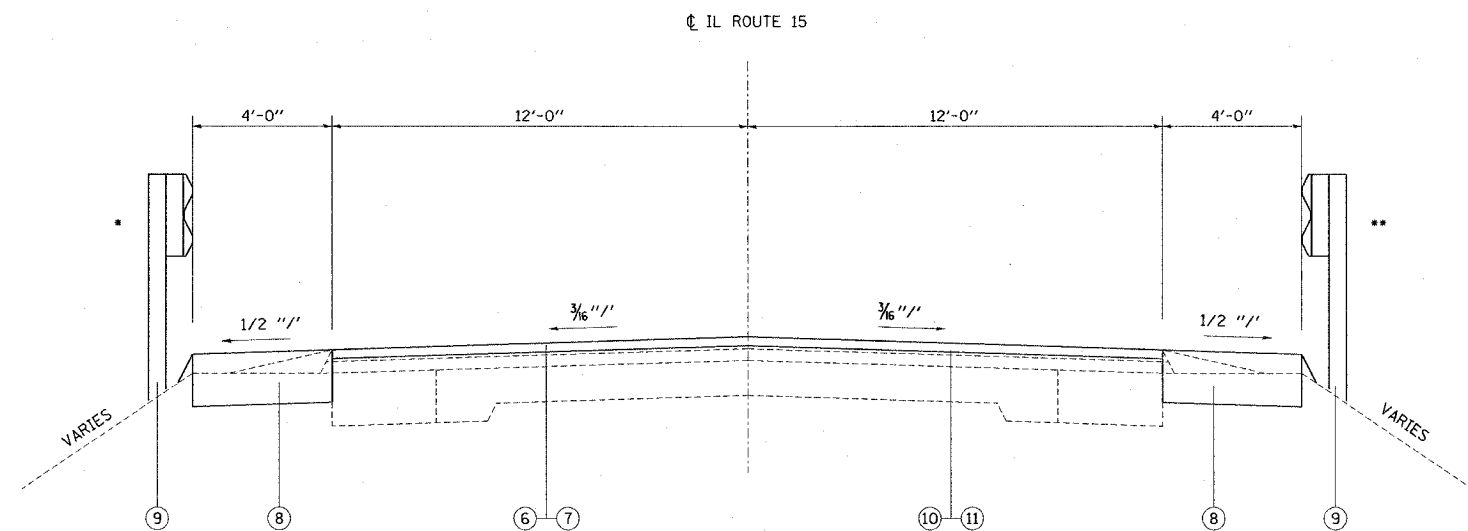

• 0010- STA 24+83 TO STA 25+53
 0011- STA 34+64 TO STA 39+10

•• 0010- STA 23+61 TO STA 27+50
 0011- STA 34+43 TO STA 37+97

PROPOSED TYPICAL SECTION

0010- STA 22+83 TO STA 24+76.58
 STA 25+59.42 TO STA 27+00
 0011- STA 34+50 TO STA 35+76.79
 STA 36+48.63 TO STA 38+00

REVISIONS	
NAME	DATE

ILLINOIS DEPARTMENT OF TRANSPORTATION
TYPICAL SECTION
 FAP ROUTE 817
 SECTION 8BR-2, 8BR-3
 WASHINGTON COUNTY
 SN 095-0010 & 0011

DATE = #DATE
 FILE NAME = #FILE
 PLOT SCALE = #SCALE
 REFERENCE = #REF

F.A.P. RTE.	SECTION	COUNTY	TOTAL SHEETS	SHEET NO.
817	8BR-2, 8BR-3	WASHINGTON	52	7
STA.		TO STA.		
FED. ROAD DIST. NO.		ILLINOIS FED. AID PROJECT		

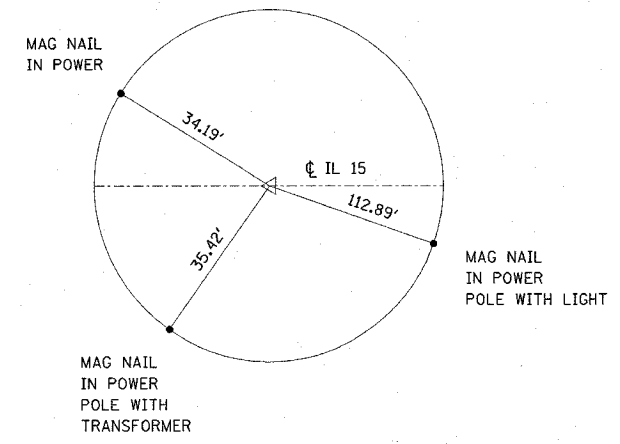

TIE POINT
MAG NAIL
P.O.L. STA 19+00

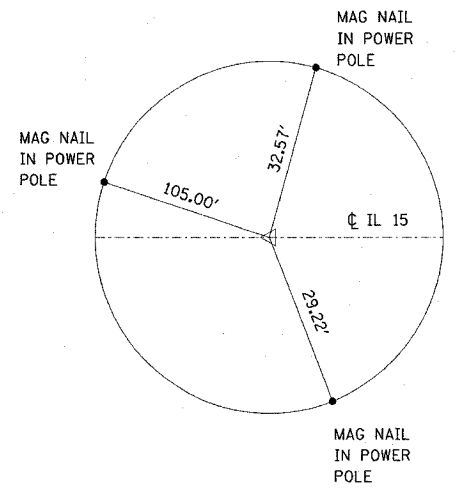

TIE POINT
MAG NAIL
P.C. STA 21+80.11

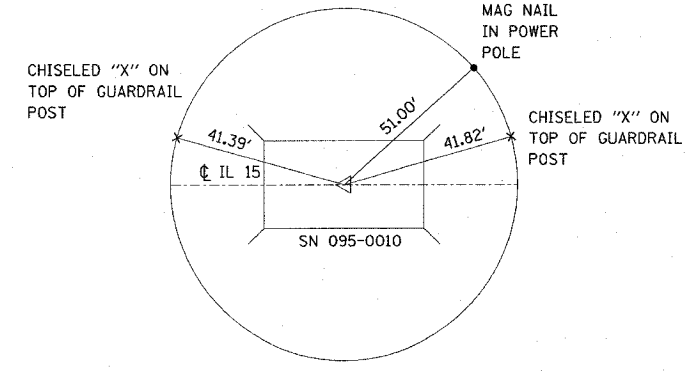

TIE POINT
MAG NAIL
C.O.B. STA 25+18.00

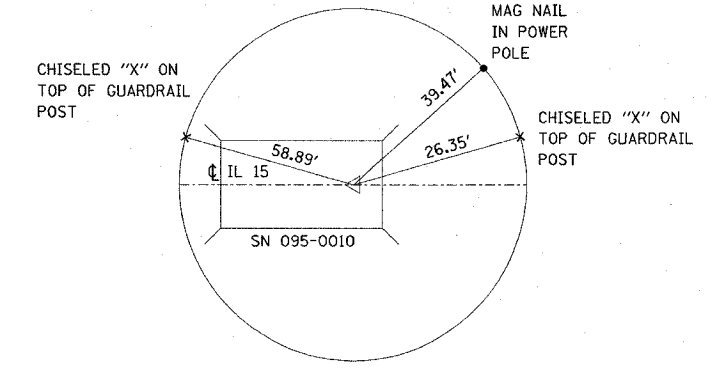

TIE POINT
MAG NAIL
P.T. STA 25+36.71

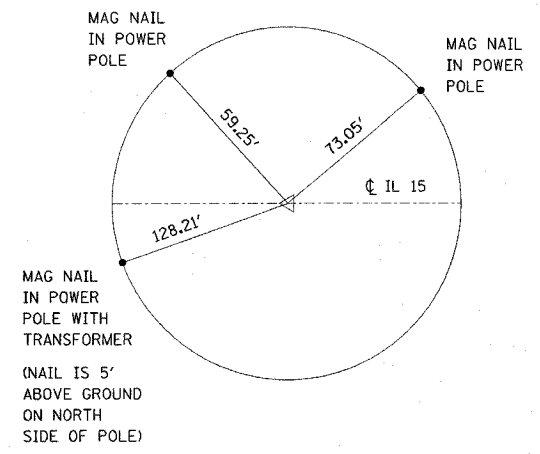

TIE POINT
MAG NAIL
P.C. STA 31+36.15

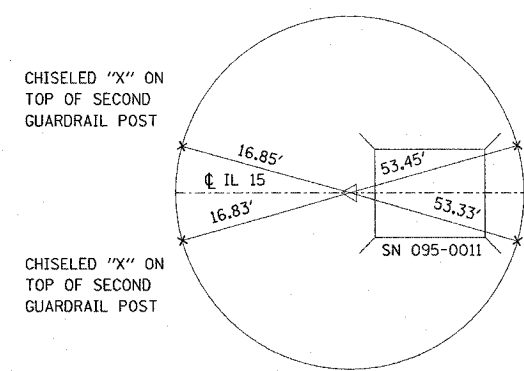

TIE POINT
MAG NAIL
P.T. STA 35+87.26

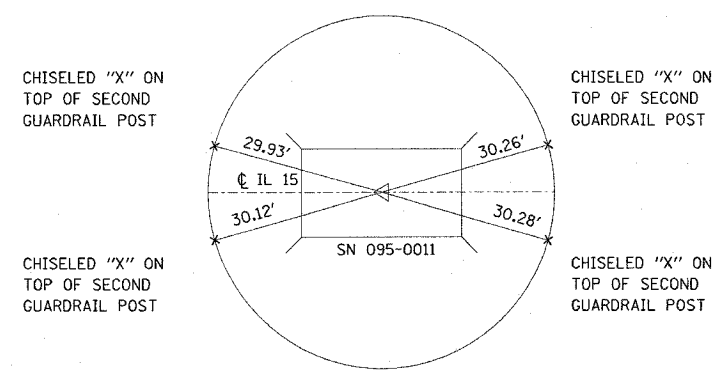

TIE POINT
MAG NAIL
C.O.B. STA 36+12.71

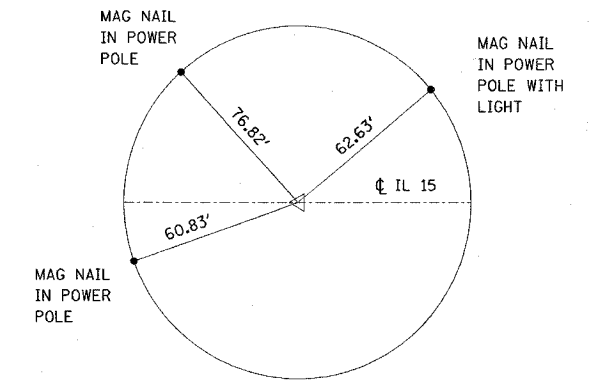

TIE POINT
MAG NAIL
P.O.L. STA 42+00

TEMPORARY BENCHMARKS

TBM 702 - CUT ON WESTMOST CORNER OF CONCRETE FOUNDATION FOR TRAFFIC SIGNAL CONTROL BOX ON SE CORNER OF IL RTE 127 AND IL RTE 15 IN NASHVILLE. ELEV = 517.914

TBM-1 - "X" CUT ON S. TOP FLANGE BOLT ON FIRE HYDRANT ON N. SIDE OF IL RTE 15 IN FRONT OF HOUSE #1117 STA 24+26 OFFSET = 25' LT ELEV = 483.910

TBM-2 - RR SPIKE IN S. SIDE OF POWERPOLE ON N. SIDE OF IL RTE 15, APPROX. 175' E. OF NE CORNER OF SN 095-0010 BRIDGE DECK. STA 27+32 OFFSET = 33' LT ELEV = 482.692

TBM-3 - RR SPIKE IN S. SIDE OF POWERPOLE ON N. SIDE OF IL RTE 15, APPROX. 18' W. AND 18' N. OF NW CORNER OF SN 095-0011 BRIDGE DECK STA 35+58 OFFSET = 33' LT ELEV = 489.842

TBM-4 - RR SPIKE IN N. SIDE OF POWERPOLE ON S. SIDE OF IL RTE 15, APPROX. 142' W. OF W. END OF GUARDRAIL FOR BRIDGE SN 095-0011. STA 33+50 OFFSET = 31' RT ELEV = 484.484

NOTE: ALL TIES PULLED DIRECT

PLOT DATE = 04/28/05
FILE NAME = 071011.DWG
PLOT SCALE = 1"=40'
REFERENCE = 071011.DWG

REVISIONS	
NAME	DATE

ILLINOIS DEPARTMENT OF TRANSPORTATION
TIE POINTS AND BENCHMARKS
FAP ROUTE 817
SECTION 8BR-2, 8BR-3
WASHINGTON COUNTY
SN 095-0010 & 0011

F.A.P. RTE.	SECTION	COUNTY	TOTAL SHEETS	SHEET NO.
817	8BR-2, 8BR-3	WASHINGTON	52	8
STA.		TO STA.		
FED. ROAD DIST. NO.		ILLINOIS FED. AID PROJECT		

NOTES

- ① ALL SIGNS REQUIRED WILL BE SUPPLIED TO THE CONTRACTOR BY I.D.O.T.
- ② THE CONTRACTOR SHALL FURNISH THE POSTS AND ERECT SIGNS AT THE LOCATIONS SHOWN ON THIS SHEET, AS DIRECTED BY THE R.E./R.T. THE POSTS SHALL REMAIN THE PROPERTY OF THE CONTRACTOR.
- ③ THE CONTRACTOR SHALL GIVE ILLINOIS DEPARTMENT OF TRANSPORTATION, BUREAU OF OPERATIONS TWO WEEKS NOTICE FOR SIGNS. THE CONTRACTOR SHALL PICK UP THE SIGNS AT THE T.M. BUILDING IN FAIRVIEW HGTS., AND RETURN THEM UPON COMPLETION OF THE CONTRACT.
- ④ THE ABOVE NOTED WORK SHALL BE PAID FOR AT THE CONTRACT UNIT PRICE, LUMP SUM, FOR "WIDE LOAD SIGNING" AND NO OTHER COMPENSATION WILL BE ALLOWED.
- ⑤ SIGN SPACING WILL BE 400' OR TO FIT FIELD CONDITIONS.
- ⑥ THE HEIGHT TO THE BOTTOM OF THE LOWEST SIGN SHALL NOT BE LESS THAN 6'.

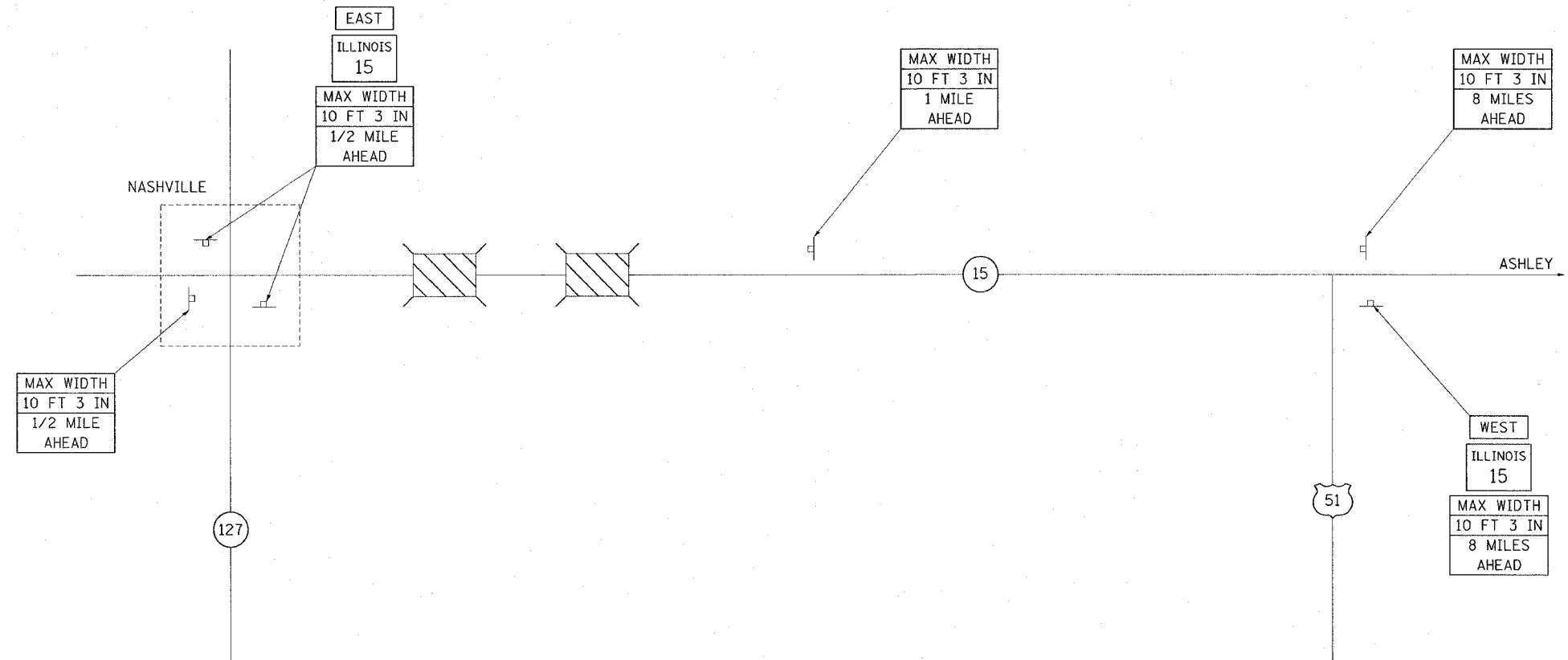

SIGNS REQUIRED			
EAST	(2)	MAX WIDTH 10 FT 3 IN 1/2 MILE AHEAD	(3)
WEST	(1)	MAX WIDTH 10 FT 3 IN 1 MILE AHEAD	(1)
ILLINOIS 15	(3)	MAX WIDTH 10 FT 3 IN 8 MILES AHEAD	(2)

PLOT DATE = #DATE#
 FILE NAME = #FILE#
 PLOT SCALE = #SCALE#
 REFERENCE = #REF#

REVISIONS	
NAME	DATE

ILLINOIS DEPARTMENT OF TRANSPORTATION
WIDE LOAD SIGNING
 FAP ROUTE 817
 SECTION 8BR-2, 8BR-3
 WASHINGTON COUNTY
 SN 095-0010 & 0011

F.A.P. RTE.	SECTION	COUNTY	TOTAL SHEETS	SHEET NO.
817	8BR-2	WASHINGTON	52	9
STA.		TO STA.		
FED. ROAD DIST. NO.		ILLINOIS FED. AID PROJECT		

EARTHWORK SCHEDULE

LOCATION STATION TO STATION	EARTH EXCAVATION (WIDENING)	EARTH EXCAVATION	EARTH EXCAVATION ADJUSTED FOR SHRINKAGE (25%)	EMBANKMENT	EARTHWORK BALANCE WASTE (+) OR SHORTAGE (-)
	CU YD	CU YD	CU YD	CU YD	CUYD
STA 22+83.0 TO STA 23+00.0	1.9		1.4		1.4
STA 23+00.0 TO STA 23+50.0	5.8	0.8	4.9	4.5	0.4
STA 23+50.0 TO STA 24+00.0	5.8	7.0	9.6	6.9	2.7
STA 24+00.0 TO STA 24+50.0	5.8	10.4	12.0	3.9	8.1
STA 24+50.0 TO STA 24+90.0	5.0	8.0	9.7	31.7	-22.0
STA 24+90.0 TO STA 24+96.5		1.2	0.9	10.0	-9.1
SN 095-0010					
STA 25+39.5 TO STA 25+50.0		2.1	1.6	12.8	-11.2
STA 25+50.0 TO STA 26+05.0	5.1	5.5	7.9	35.0	-27.1
STA 26+05.0 TO STA 26+50.0	5.0		3.8	1.6	2.2
STA 26+50.0 TO STA 27+00.0	5.6		4.2	0.5	3.7
STA 27+00.0 TO STA 27+50.0				2.2	-2.2
STA 27+50.0 TO STA 28+00.0				1.9	-1.9
SUBTOTAL	40	35	56	111	-55

RESURFACING SCHEDULE

LOCATION STATION TO STATION	BITUMINOUS MATERIALS (PRIME COAT)	AGGREGATE (PRIME COAT)	BIUTMINOUS CONCRETE SURFACE COURSE, SUPERPAVE	BITUMINOUS SURFACE REMOVAL - 2"
	TON	TON	TON	SQ YD
STA 22+83.0 TO STA 23+00.0	0.04	0.17	5.1	45.3
STA 23+00.0 TO STA 23+50.0	0.04	0.20	14.9	133.6
STA 23+50.0 TO STA 24+00.0	0.04	0.20	14.9	133.6
STA 24+00.0 TO STA 24+50.0	0.04	0.20	14.9	133.6
STA 24+50.0 TO STA 24+76.6	0.04	0.21	7.9	70.9
STA 24+76.6 TO STA 24+96.5	0.04	0.21	8.2	73.0
STA 25+39.5 TO STA 25+59.4	0.04	0.21	8.2	73.0
STA 25+59.4 TO STA 26+05.0	0.04	0.20	13.6	121.5
STA 26+05.0 TO STA 26+50.0	0.04	0.20	13.4	120.0
STA 26+50.0 TO STA 27+00.0	0.04	0.20	14.9	133.5
TOTAL	0.4	2	116 *	1038

* BITUMINOUS CONCRETE SURFACE COURSE IS NOT A TOTAL QUANTITY. SEE BRIDGE PLANS FOR ADDITIONAL QUANTITY.

ROW MARKERS SCHEDULE

LOCATION STATION	OFFSET	SIDE	FURNISHING & ERECTING RIGHT-OF-WAY MARKERS	RIGHT-OF-WAY AND PROPERTY CORNERS
			EACH	EACH
STA 23+45.00	28.66	RT	1	
STA 24+11.09	42.87	RT	1	
STA 26+46.11	30.00	RT	1	
STA 24+60.00	28.83	LT	1	1
STA 24+85.00	50.39	LT	1	1
STA 25+33.86	53.81	LT	1	
STA 25+75.00	36.86	LT	1	
TOTAL			7	2

TEMPORARY RAMP SCHEDULE

LOCATION	WIDTH	LENGTH	TEMPORARY RAMP
	FOOT	FOOT	SQ YD
STA 22+83	24	6.75	18
STA 27+00	24	6.75	18
TOTAL			36

GUARDRAIL SCHEDULE

LOCATION	GUARDRAIL REMOVAL	STEEL PLATE BEAM GUARDRAIL, TYPE A	TRAFFIC BARRIER TERMINAL, TYPE 1, SPC (TANGENT)	TRAFFIC BARRIER TERMINAL, TYPE 2	TRAFFIC BARRIER TERMINAL, TYPE 6A	GUARDRAIL MARKERS, TYPE A	TERMINAL MARKER - DIRECT APPLIED
	FOOT	FOOT	EACH	EACH	EACH	EACH	EACH
EB IL 15						4	
WB IL 15						2	
NW QUADRANT	12.5			1	1		
NE QUADRANT	12.5			1	1		
SW QUADRANT	100	50	1		1		1
SE QUADRANT	100	75	1		1		1
TOTAL	225	125	2	2	4	6	2

STAGING SCHEDULE

LOCATION	BITUMINOUS BASE COURSE WIDENING, 9"	TEMPORARY RUMBLE STRIPS	TEMPORARY CONCRETE BARRIER	RELOCATE TEMPORARY CONCRETE BARRIER	TEMPORARY PAVEMENT MARKING - LINE 6"	IMPACT ATTENUATOR, TEMPORARY (NON-REDIRECTIVE)	IMPACT ATTENUATOR, TEMPORARY (FULLY REDIRECTIVE, NARROW)	IMPACT ATTENUATOR, RELOCATE (NON-REDIRECTIVE)
	SQ YD	EACH	FOOT	FOOT	FOOT	EACH	EACH	EACH
PRE-STAGE I	297							
STAGE I		3	200		200	2		
STAGE II				87.5	87.5		1	1
TOTAL	297	3	200	87.5	287.5	2	1	1

PAVEMENT MARKING SCHEDULE

LOCATION STATION TO STATION	PAVEMENT MARKING REMOVAL				THERMOPLASTIC PAVEMENT MARKING				TEMPORARY PAVEMENT MARKING LINE - 4"	SHORT-TERM PAVEMENT MARKING	WORK ZONE PAVEMENT MARKING REMOVAL	RAISED REFLECTIVE PAVEMENT MARKER REMOVAL	REPLACEMENT REFLECTOR	RAISED REFLECTIVE PAVEMENT MARKER
	SOLID CENTERLINE 4" YELLOW	SKIP-DASH CENTERLINE 4" YELLOW	EDGE LINE 4" WHITE		SOLID CENTERLINE 4" YELLOW	SKIP-DASH CENTERLINE 4" YELLOW	EDGE LINE 4" WHITE							
			LT	RT			LT	RT						
STA 22+40.00 TO STA 28+06.00	189	50	188.5	188.5	566	150	566	566	1848	52	633	7	2	5
SUB-TOTAL	189	50	188.5	188.5	566	150	566	566						
TOTAL				616			1848		1848	52	633	7	2	5

ALL QUANTITIES ON THIS SHEET ARE NOT TOTAL PROJECT QUANTITIES. THE QUANTITIES ON THIS SHEET ARE THE TOTAL FOR SN 095-0010.

REVISIONS		ILLINOIS DEPARTMENT OF TRANSPORTATION
NAME	DATE	
		<p>SCHEDULE OF QUANTITIES</p> <p>FAP ROUTE 817 SECTION 8BR-2 WASHINGTON COUNTY SN 095-0010</p>

F.A.P. RTE.	SECTION	COUNTY	TOTAL SHEETS	SHEET NO.
817	8BR-2	WASHINGTON	52	10
STA. 22+20		TO STA. 28+20		
FED. ROAD DIST. NO.	ILLINOIS FED. AID PROJECT			

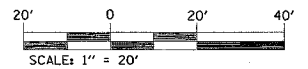
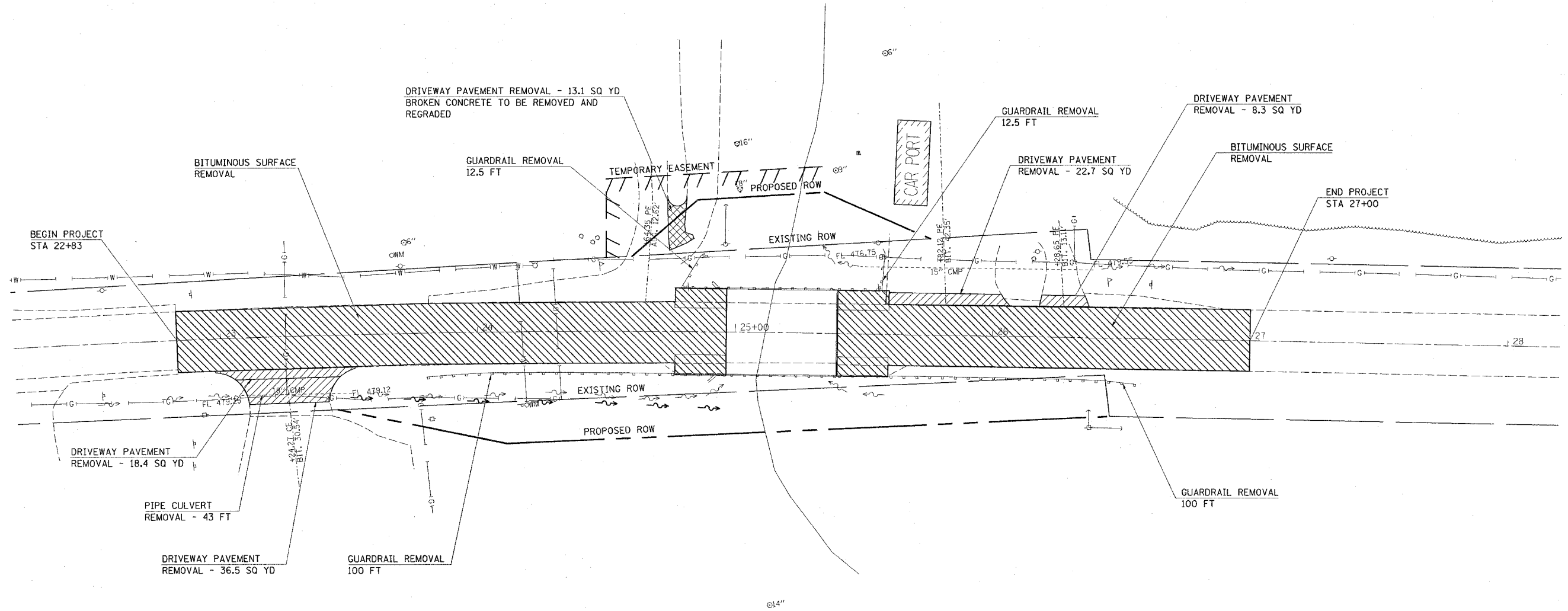

REVISIONS	
NAME	DATE

ILLINOIS DEPARTMENT OF TRANSPORTATION
REMOVAL PLAN
 FAP ROUTE 817
 SECTION 8BR-2
 WASHINGTON COUNTY
 SN 095-0010

PLOT DATE = #DATE#
 FILE NAME = #FILE#
 PLOT SCALE = #SCALE#
 REFERENCE = #REF#

F.A.P. RTE.	SECTION	COUNTY	TOTAL SHEETS	SHEET NO.
817	8BR-2	WASHINGTON	52	12
STA. 22+20		TO STA. 28+20		
FED. ROAD DIST. NO.		ILLINOIS FED. AID PROJECT		



EXIST. CURVE C1
 PI STA. = 23+58.51
 $\Delta = 4^{\circ} 41' 55''$ (RT)
 $D = 1^{\circ} 19' 03''$
 $R = 4,348.51'$
 $T = 178.40'$
 $L = 356.60'$
 $E = 3.66'$
 $\theta = \dots$
 $T.R. = \dots$
 $S.E. RUN = \dots$
 $P.C. STA. = 21+80.11$
 $P.T. STA. = 25+36.71$

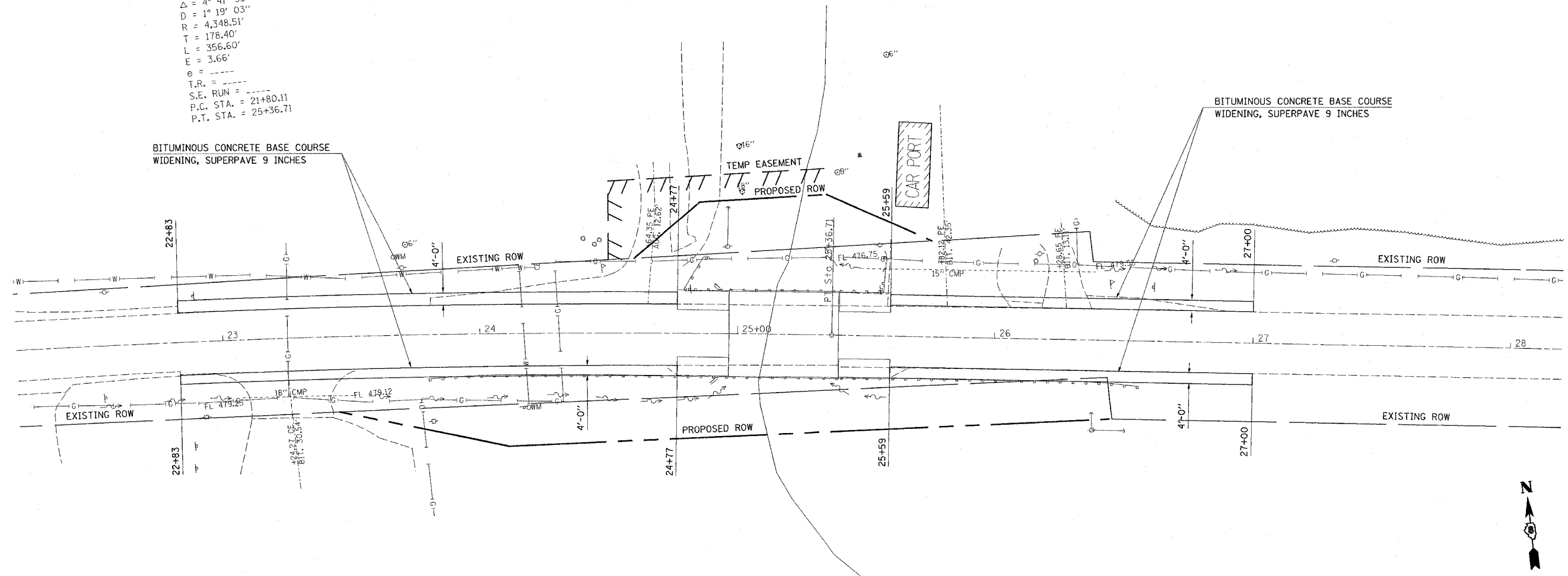

PRE-STAGE I DESCRIPTION OF WORK:

"BITUMINOUS CONCRETE BASE COURSE WIDENING, SUPERPAVE 9 INCHES" SHALL BE CONSTRUCTED TO ALLOW FOR TRAFFIC IN STAGE I AND II.

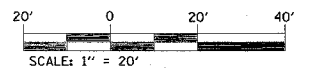





PLOT DATE = 7/18/2006
 FILE NAME = c:\p\proj\va\88995\plan\11988985.dwg
 PLOT SCALE = 26.0000 / IN.
 USER NAME = owerby

REVISIONS	
NAME	DATE

ILLINOIS DEPARTMENT OF TRANSPORTATION
STAGE CONSTRUCTION
PRE-STAGE I
 FAP ROUTE 817
 SECTION 8BR-2
 WASHINGTON COUNTY
 SN 095-0010

F.A.P. RTE.	SECTION	COUNTY	TOTAL SHEETS	SHEET NO.
817	8BR-2	WASHINGTON	52	13
STA. 22+20		TO STA. 28+20		
FED. ROAD DIST. NO.		ILLINOIS FED. AID PROJECT		

LEGEND

-  IMPACT ATTENUATOR
-  TEMPORARY CONCRETE BARRIER
-  BARRELS OR BARRICADES WITH STEADY BURNING LIGHT
-  TEMPORARY BRIDGE TRAFFIC SIGNALS
-  TYPE III BARRICADE

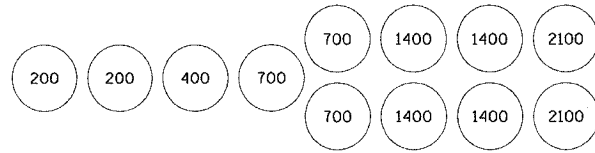

SAND BARREL LAYOUT
(IF OPTION USED)

EXIST. CURVE C1
 PI STA. = 23+58.51
 $\Delta = 4^\circ 41' 55''$ (RT)
 $D = 1^\circ 19' 03''$
 $R = 4,348.51'$
 $T = 178.40'$
 $L = 356.60'$
 $E = 3.66'$
 $e = \dots$
 $T.R. = \dots$
 $S.E. RUN = \dots$
 $P.C. STA. = 21+80.11$
 $P.T. STA. = 25+36.71$

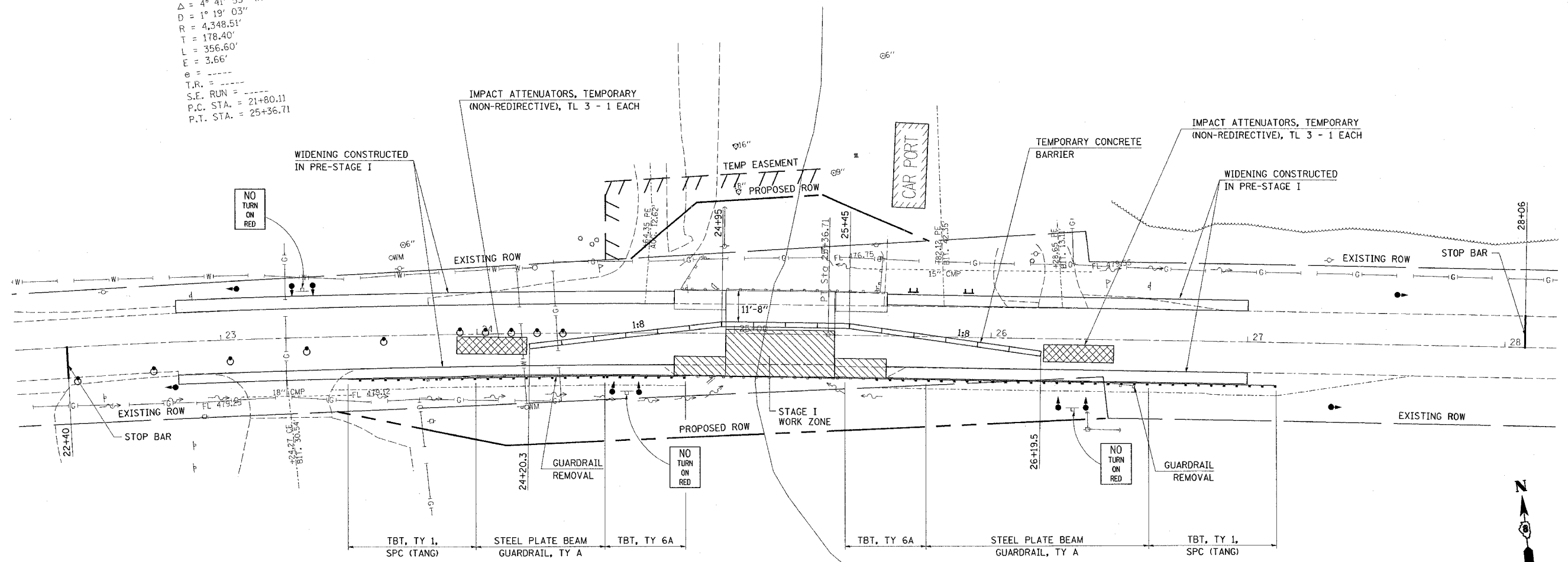

SEQUENCE OF CONSTRUCTION:

THE CONTRACTOR SHALL GIVE ILLINOIS DEPARTMENT OF TRANSPORTATION, BUREAU OF OPERATIONS TWO WEEKS NOTICE FOR PREPARATION OF THE STATE FURNISHED TRAFFIC CONTROLLER. THE CONTRACTOR SHALL PICK UP THE TRAFFIC CONTROLLER AT THE T.M. BUILDING.

PLACE STOP BARS AS SHOWN ON PLANS.

PLACE TEMPORARY RUMBLE STRIPS (3 EACH) EAST OF STRUCTURE FOR WESTBOUND TRAFFIC.

REMOVE CENTERLINE AND CONFLICTING SOLID EDGE PAVEMENT MARKINGS BETWEEN STOP BARS.

PLACE 200 FT TEMPORARY CONCRETE BARRIER AND 2 EACH IMPACT ATTENUATORS, TEMPORARY.

SEE STANDARD 701321 FOR DETAILS NOT SHOWN ON PLANS.

PERFORM ALL NECESSARY BRIDGE WORK IN STAGE I WORK ZONE.

REMOVE EXISTING GUARDRAIL ON SOUTH SIDE AND REPLACE WITH PROPOSED STEEL PLATE BEAM GUARDRAIL, TYPE A, TBT TYPE 6A AND TBT, TYPE 1 (SPECIAL) TANGENT IN SW AND SE QUADRANTS

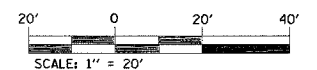





REVISIONS	
NAME	DATE

ILLINOIS DEPARTMENT OF TRANSPORTATION
STAGE CONSTRUCTION
STAGE I
 FAP ROUTE 817
 SECTION 8BR-2
 WASHINGTON COUNTY
 SN 095-0010

PLOT DATE = 7/19/2006
 FILE NAME = C:\Users\jg89985\Documents\889985\plan\stage0905.dwg
 PLOT SCALE = 20.00000 / IN.
 USER NAME = jg89985

F.A.P. RTE.	SECTION	COUNTY	TOTAL SHEETS	SHEET NO.
817	8BR-2	WASHINGTON	52	14
STA. 22+20		TO STA. 28+20		
FED. ROAD DIST. NO.		ILLINOIS	FED. AID PROJECT	

LEGEND

-  IMPACT ATTENUATOR
-  TEMPORARY CONCRETE BARRIER
-  BARRELS OR BARRICADES WITH STEADY BURNING LIGHT
-  TEMPORARY BRIDGE TRAFFIC SIGNALS
-  TYPE III BARRICADE

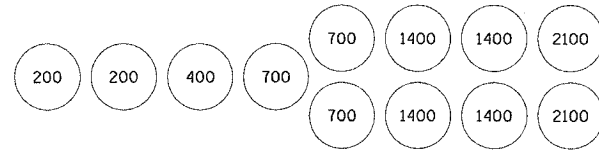

SAND BARREL LAYOUT
(IF OPTION USED)

EXIST. CURVE C1
 PI STA. = 23+58.51
 $\Delta = 4^\circ 41' 55''$ (RT)
 $D = 1^\circ 19' 03''$
 $R = 4,348.51'$
 $T = 178.40'$
 $L = 356.60'$
 $E = 3.66'$
 $\theta = \dots$
 $T.R. = \dots$
 $S.E. RUN = \dots$
 $P.C. STA. = 21+80.11$
 $P.T. STA. = 25+36.71$

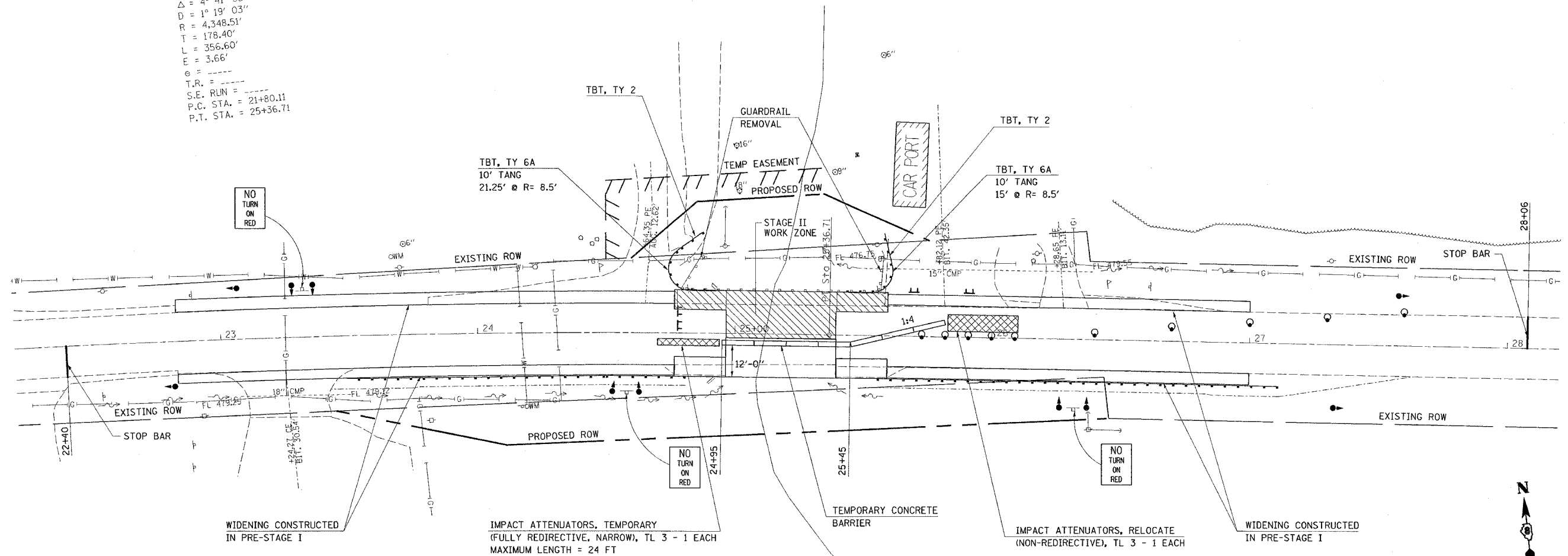

SEQUENCE OF CONSTRUCTION:

- REMOVE 150 FT AND RELOCATE 50 FT OF TEMPORARY CONCRETE BARRIER.
- RELOCATE 1 EACH IMPACT ATTENUATORS (NON-REDIRECTIVE) AND PLACE 1 EACH IMPACT ATTENUATORS (FULLY REDIRECTIVE, NARROW) WITH A MAXIMUM LENGTH OF 24 FT.
- SEE STANDARD 701321 FOR DETAILS NOT SHOWN ON PLANS.
- PERFORM ALL NECESSARY BRIDGE WORK IN STAGE II WORK ZONE.
- REMOVE EXISTING GUARDRAIL ON NORTH SIDE AND REPLACE WITH PROPOSED TBT TYPE 6A, AND TBT, TYPE 2 TANGENT IN NW AND NE QUADRANTS



REVISIONS	
NAME	DATE



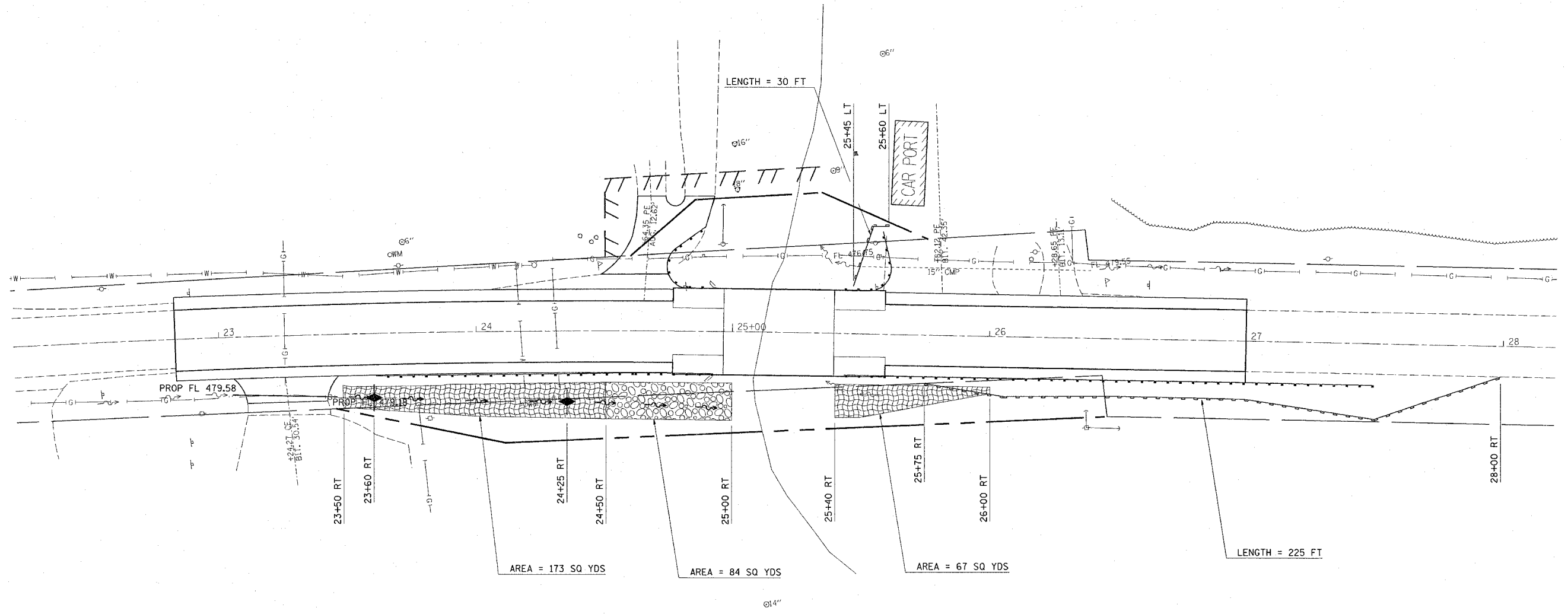

ILLINOIS DEPARTMENT OF TRANSPORTATION
STAGE CONSTRUCTION
STAGE II
 FAP ROUTE 817
 SECTION 8BR-2
 WASHINGTON COUNTY
 SN 095-0010

PLOT DATE = 7/19/2006
 PLOT SCALE = 1/4" = 10'
 PLOT USER = SKW
 USER NAME = SKW

F.A.P. RTE.	SECTION	COUNTY	TOTAL SHEETS	SHEET NO.
817	8BR-2	WASHINGTON	52	15
STA. 22+20		TO STA. 28+20		
FED. ROAD DIST. NO.		ILLINOIS	FED. AID PROJECT	



LEGEND

-  TEMPORARY DITCH CHECK- ROLLED EXCELSIOR, SILT WEDGES/PANELS
-  EROSION CONTROL BLANKET
-  PERIMETER EROSION BARRIER- SILT FILTER FENCE OR OTHER AS APPROVED BY THE ENGINEER
-  STONE RIPRAP, CLASS A3



REVISIONS	
NAME	DATE

ILLINOIS DEPARTMENT OF TRANSPORTATION
EROSION CONTROL SHEET
 FAP ROUTE 817
 SECTION 8BR-2
 WASHINGTON COUNTY
 SN 095-0010

PLOT DATE = #DATE#
 FILE NAME = #FILE#
 PLOT SCALE = #SCALE#
 REFERENCE = #REF#

PART OF THE NE 1/4 OF SECTION 24, T2S, R3W, AND PART OF THE NW 1/4, SEC. 19, T2S, R2W OF THE 3RD PM, WASHINGTON COUNTY, ILLINOIS

BEARINGS SHOWN HEREON ARE BASED ON SURVEY CONTROL DATA AS PROVIDED BY THE ILLINOIS DEPARTMENT OF TRANSPORTATION.

FAP ROUTE	SECTION	COUNTY	TOTAL SHEETS	SHEET NO.
817	2, 8BR-3	WASHINGTON	52	16
STA. 18+08.68	TO STA. 29+73.16			
CONTRACT NO.:				

COORDINATES SHOWN HEREON ARE BASED ON SURVEY CONTROL DATA AS PROVIDED BY THE ILLINOIS DEPARTMENT OF TRANSPORTATION.

STATION	OFFSET	NORTH	EAST
18+08.68	POT	611529.6570	523889.0380
CI 21+80.11	PC CURVE	611512.9186	524260.0913
CI 23+58.51	PI CURVE	611504.8791	524438.3083
CI 25+36.71	PT CURVE	611482.2685	524615.2680
26+62.65	150.21' RT	611317.3112	524721.1564
25+67.50	541.36' LT	612015.3607	524714.4228
24+90.48	1,201.03' LT	612680.7836	524708.9328
28+31.10	1,474.19' RT	609982.6528	524720.4437
23+45.00	28.66' RT	611473.8010	524422.2546
26+46.11	30.00' RT	611438.6445	524719.9860
24+11.09	42.87' RT	611453.7263	524486.2425
24+60.00	28.83' LT	611519.9742	524542.2444
24+50.00	28.26' LT	611520.4963	524532.1762
24+50.00	58.30' LT	611550.3700	524535.3893
25+32.52	63.74' LT	611546.0274	524619.1343

STATION	OFFSET	NORTH	EAST
25+33.86	53.81' LT	611536.0090	524619.2309
25+75.00	36.86' LT	611513.9758	524657.9215
24+85.00	50.39' LT	611538.5758	524569.7302
26+36.28	41.48' LT	611510.7935	524719.2900
26+37.86	30.00' RT	611499.2069	524719.4018
35+87.26	30.00' LT	611424.3285	525657.8382
35+87.26	30.00' RT	611364.4941	525662.2924
31+36.15	30.00' LT	611436.0525	525213.6731
31+36.15	30.00' RT	611376.5363	525206.0686

LEGEND

- EXISTING CENTERLINE
- EXISTING RIGHT OF WAY LINE
- EXISTING EASEMENT LINE
- PROPOSED CENTERLINE
- PROPOSED RIGHT OF WAY LINE
- PROPOSED TEMPORARY EASEMENT LINE
- PROPOSED PERMANENT EASEMENT LINE
- SECTION LINE
- QUARTER SECTION LINE
- PROPERTY QUARTER SECTION LINE
- PROPERTY (DEED) LINE
- APPARENT PROPERTY LINE
- MEASURED DIMENSION
- RECORDED PLAT DIMENSION
- DEED DIMENSION
- FOUND IRON PIPE OR IRON ROD AT CORNER UNLESS OTHERWISE NOTED
- SET 5/8 INCH IRON ROD AT CORNER UNLESS OTHERWISE NOTED
- PERMANENT SURVEY MONUMENT, I.D.O.T. STD. 667101 (TO BE SET BY OTHERS)
- CUT CROSS FOUND OR SET
- SAME OWNERSHIP
- EXISTING BUILDING

STAKING OF PROPOSED RIGHT OF WAY. SET 5/8 INCH METAL ROD WITH DIVISION OF HIGHWAY SURVEY MARKER TO MONUMENT THE POSITION SHOWN, IDENTIFIED BY INSCRIPTION DATA AND SURVEYORS REGISTRATION NUMBER.

STAKING OF PROPOSED RIGHT OF WAY IN CULTIVATED AREAS. SET 5/8 INCH METAL ROD WITH DIVISION OF HIGHWAY SURVEY MARKER 20 INCHES BELOW GROUND SURFACE TO MONUMENT THE POSITION SHOWN, IDENTIFIED BY INSCRIPTION DATA AND SURVEYORS REGISTRATION NUMBER.

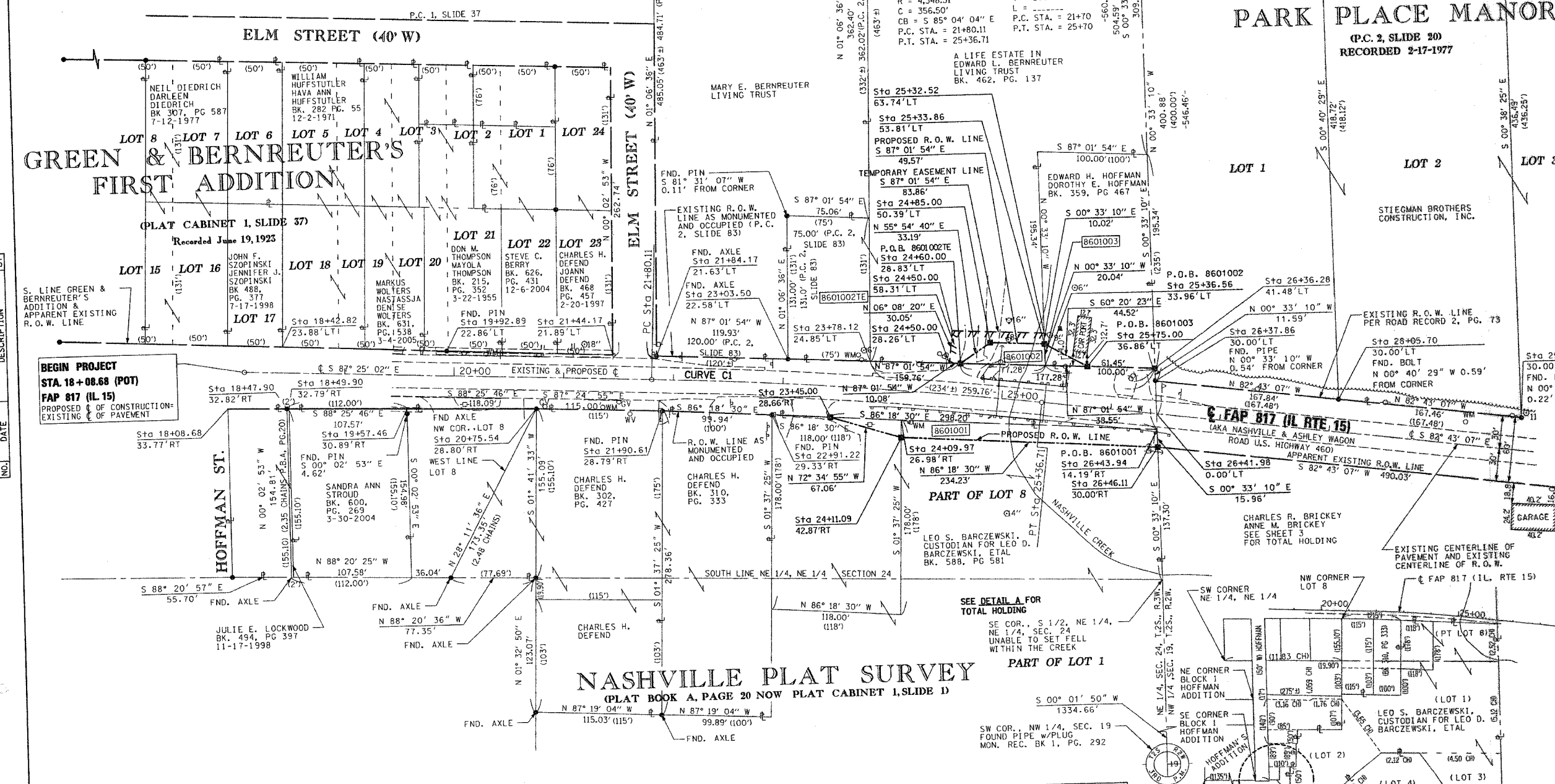

NO.	DATE	DESCRIPTION	BY

BEGIN PROJECT
 STA. 18+08.68 (POT)
 FAP 817 (IL 15)
 PROPOSED & OF CONSTRUCTION- EXISTING & OF PAVEMENT

STATE OF ILLINOIS
 COUNTY OF WASHINGTON
 I, TONY HARD, AN ILLINOIS PROFESSIONAL LAND SURVEYOR, CERTIFY THAT I HAVE SURVEYED THE PLAT OF HIGHWAY SHOWN HEREON AND THAT THIS PROFESSIONAL SERVICE CONFORMS TO THE CURRENT ILLINOIS MINIMUM STANDARDS FOR A BOUNDARY SURVEY FOR THE PROPOSED PARCELS TO BE ACQUIRED BY THE STATE OF ILLINOIS, DEPARTMENT OF TRANSPORTATION, SHOWN HEREON.
 DATED February 9, 2006
 Tony Hard
 TONY HARD, PLS NO. 2953
 LICENSE EXPIRATION DATE: 11/30/2006

PARCEL NO.	OWNER	TOTAL HOLDING ACRES	FEE SIMPLE ACQUISITION				REMAINDER ACRES	EASEMENTS		PERMANENT TAX NUMBER	PROPERTY ACQUIRED BY
			GROSS ACRES	SQ. FT.	PREVIOUSLY DEDICATED ACRES	NET ACRES		PERMANENT ACRES	TEMPORARY ACRES		
8601001	LEO S. BARCZEWSKI AS CUSTODIAN FOR LEO D. BARCZEWSKI UNDER THE ILLINOIS UNIFORM TRANSFERS TO MINORS ACT, SHEILA ANN EATON AND PAUL J. BARCZEWSKI, EACH AS TO AN UNDIVIDED 1/3 INTEREST TITLE REPORT WA-349.0	7.7915	0.0972	4,236	N/A	N/A	0.0972	4,236	7.6943	N/A	10-12-24-278-015 & 10-12-24-278-016
8601002	A LIFE ESTATE IN EDWARD L. BERNREUTER AND MARY E. BERNREUTER LIVING TRUST DATED JUNE 27, 1996 TITLE REPORT WA-347.0	2.6672	0.0291	1,269	N/A	N/A	0.0291	1,269	2.6381	0.0298	1,300
8601003	EDWARD H. HOFFMAN AND DOROTHY E. HOFFMAN IN JOINT TENANCY TITLE REPORT WA-348.0	0.4476	0.0088	385	N/A	N/A	0.0088	385	0.4388	N/A	N/A

McDonough-Whitlow, P.C.
 Consulting Engineers & Land Surveyors
 138 East Wood Street
 Hillsboro, IL 62049
 Phone: 217.532.9233
 Fax: 217.532.6300
 PROFESSIONAL DESIGN NO. 104-002754

ILLINOIS DEPARTMENT OF TRANSPORTATION
PLAT OF HIGHWAYS
 FAP ROUTE 817 (IL 15)
 SECTION 8BR-2, 8BR-3
 WASHINGTON COUNTY
 JOB NO. R-98-001-06
 STATION 18+08.68 TO STATION 29+73.16
 SCALE: 1" = 50'
 SHEET 2 OF 3

COMPLETION DATE OF FIELD WORK PERFORMED
 LAND SURVEY: 09-23-05
 RIGHT OF WAY STAKING: 02-01-06

PLAT DATE: 02-09-06 9:10 A.M.

F.A.P. RTE.	SECTION	COUNTY	TOTAL SHEETS	SHEET NO.
817	8BR-2	WASHINGTON	52	18
STA.		TO STA.		
FED. ROAD DIST. NO.		ILLINOIS FED. AID PROJECT		

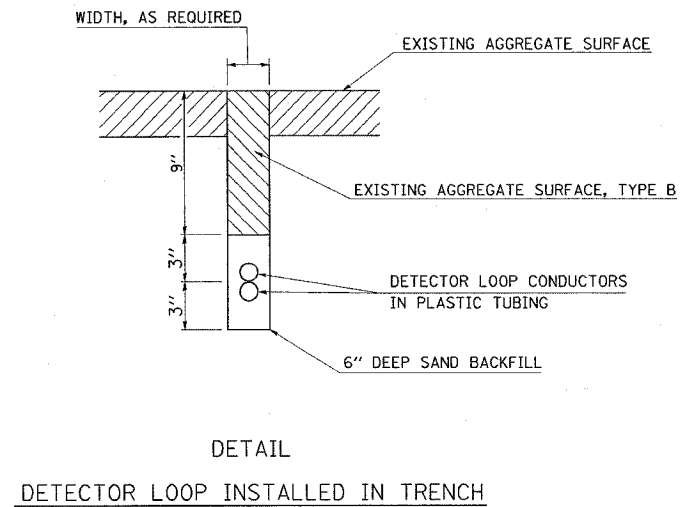

INSTALLATION IS TO BE DONE IN CONFORMANCE WITH THE REQUIREMENTS OF THE PLANS AND SECTION 886 OF THE STANDARD SPECIFICATIONS WITH THE FOLLOWING EXCEPTIONS:

1. SLOTS ARE TO BE TRENCHED INSTEAD OF SAWED.
2. THIS WORK SHALL NOT BE PAID FOR SEPARATELY BUT SHALL BE INCLUDED IN THE COST OF TEMPORARY BRIDGE TRAFFIC SIGNALS - 1 EACH.

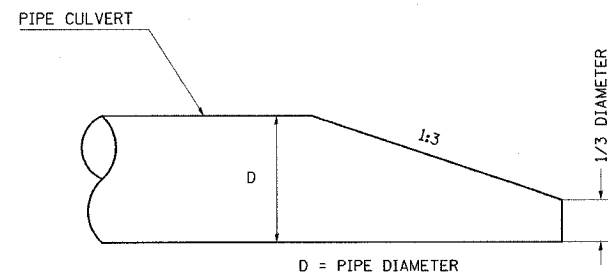

**ENTRANCE CULVERT
BEVELED END SECTION DETAIL**
THE BEVELED END PORTION SHALL BE INCLUDED IN THE UNIT PRICE PER FOOT FOR THE PIPE CULVERT

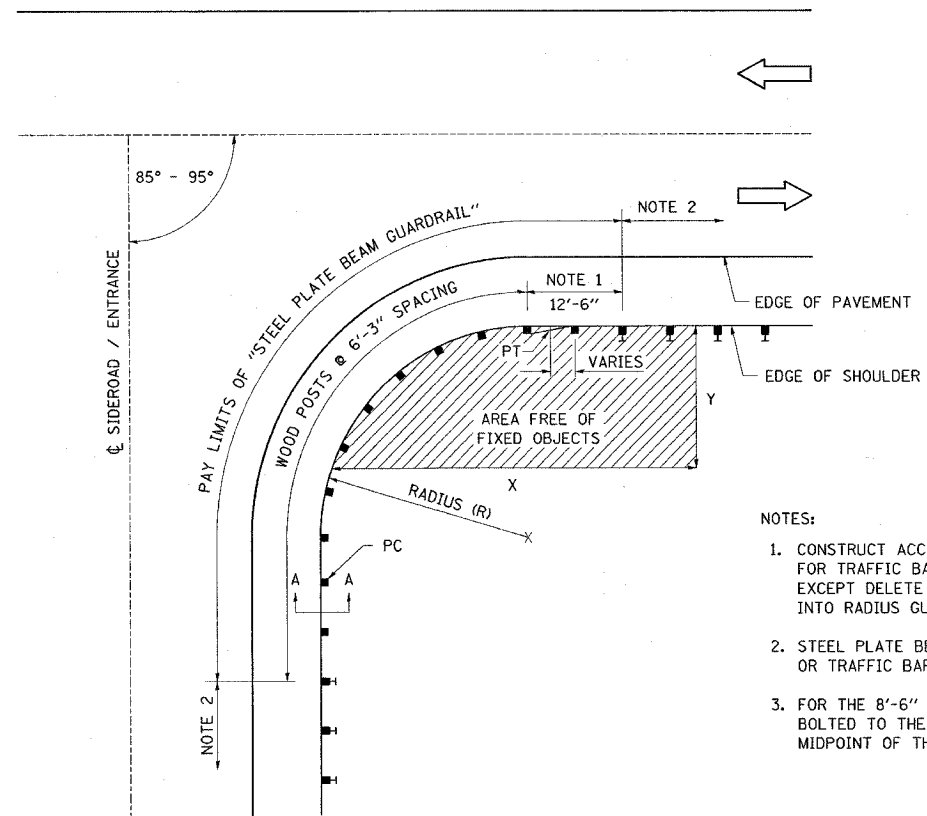

PLAN VIEW SHORT RADIUS GUARDRAIL DETAIL

NOTES:

1. CONSTRUCT ACCORDING TO STANDARD 631011 FOR TRAFFIC BARRIER TERMINAL TYPE 2, EXCEPT DELETE END SECTION AND SPLICE INTO RADIUS GUARDRAIL.
2. STEEL PLATE BEAM GUARDRAIL TYPE A, TYPE B, OR TRAFFIC BARRIER TERMINAL AS SPECIFIED.
3. FOR THE 8'-6\"/>

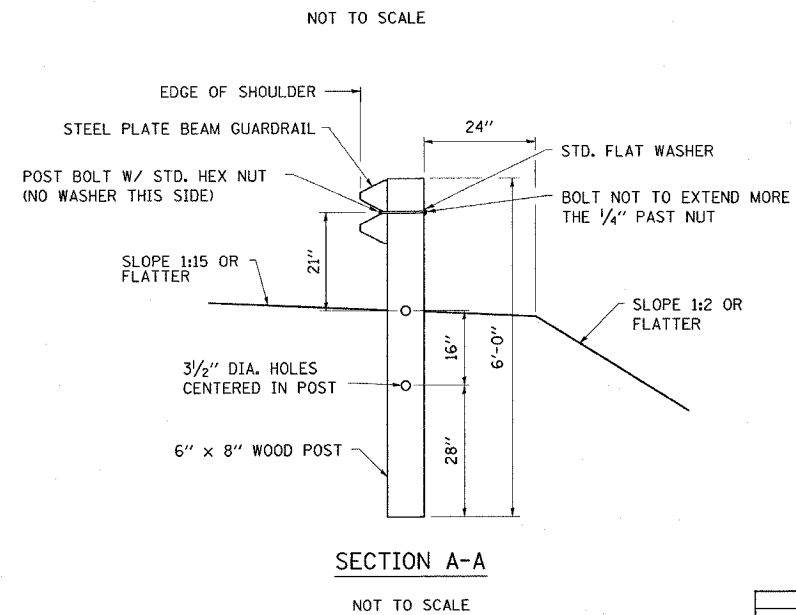

R	NO. OF WOOD POSTS	X	Y
8'-6"	5 (NOTE 3)	25'	15'
17'-0"	6	30'	15'
25'-6"	8	40'	20'
35'-0"	11	50'	20'

REVISIONS	
NAME	DATE

ILLINOIS DEPARTMENT OF TRANSPORTATION
MISCELLANEOUS DETAILS
FAP ROUTE 817
SECTION 8BR-2
WASHINGTON COUNTY
SN 095-0010

F.A.P. RTE.	SECTION	COUNTY	TOTAL SHEETS	SHEET NO.
817	8BR-2	WASHINGTON	52	19
STA. 22+20		TO STA. 28+20		
FED. ROAD DIST. NO.		ILLINOIS FED. AID PROJECT		

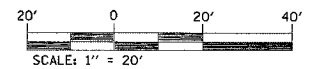
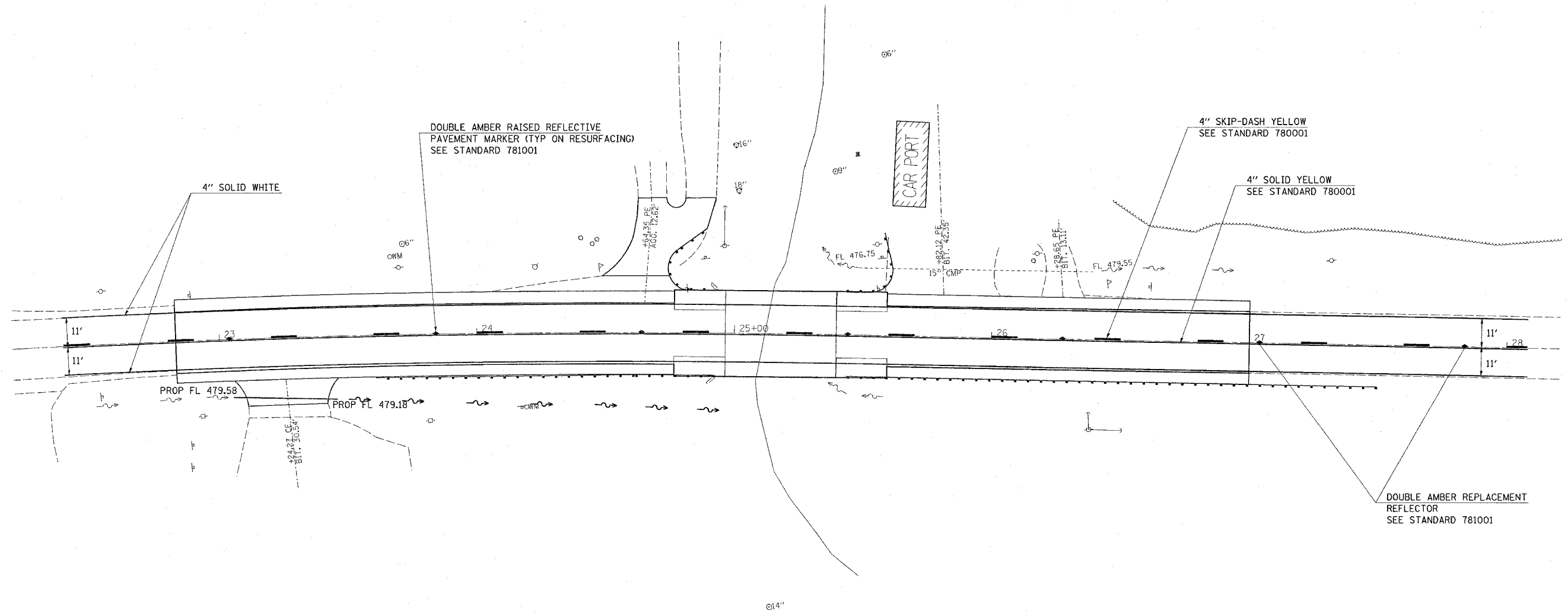

REVISIONS	
NAME	DATE

ILLINOIS DEPARTMENT OF TRANSPORTATION
PAVEMENT MARKING SHEET
 FAP ROUTE 817
 SECTION 8BR-2
 WASHINGTON COUNTY
 SN 095-0010

PLOT DATE = *DATE*
 FILE NAME = *FILE*
 PLOT SCALE = *SCALE*
 REFERENCE = *REF*

Bench Mark: RR Spike in South Side of Power Pole on North Side of Route 15, approximately 175' East of Northeast Corner of S.N. 095-0010 Bridge Deck, Elev. 482.69.

Existing Structure: S.N. 095-0010 was built in 1921 as S.B.I. Rte. 15 Sec. 8B at Sta. 25+18.00. In 1971 the superstructure was replaced, and the substructure widened. The existing single span structure consists of PPC deck beams on spread footing supported closed abutments. The bk. to bk. abts dimension measures 43'-0" while the O.-O. width measures 33'-0". The existing superstructure shall be replaced with PPC deck beams, and the substructure will be repaired with Structural Repair of Concrete. Staging shall be used during construction.

No Salvage.

STATE OF ILLINOIS
DEPARTMENT OF TRANSPORTATION

INDEX OF SHEETS

1. General Plan
2. Stage Construction Details
3. Temporary Concrete Barrier for Stage Construction
4. Type SM Steel Bridge Rail Side Mounted
5. Bridge Approach Pavement (Special)
- 6.-7. Superstructure Details
8. West Abutment
9. East Abutment
10. Abutment Repair and Concrete Removal Details

ROUTE NO.	SECTION	COUNTY	TOTAL SHEETS	SHEET NO.	SHEET NO. 1
F.A.P. 817	8BR-2, 8BR-3	WASHINGTON	52	20	10 SHEETS
FED. ROAD DIST. NO. 7	ILLINOIS	FED. AID PROJECT-	Contract #76946		

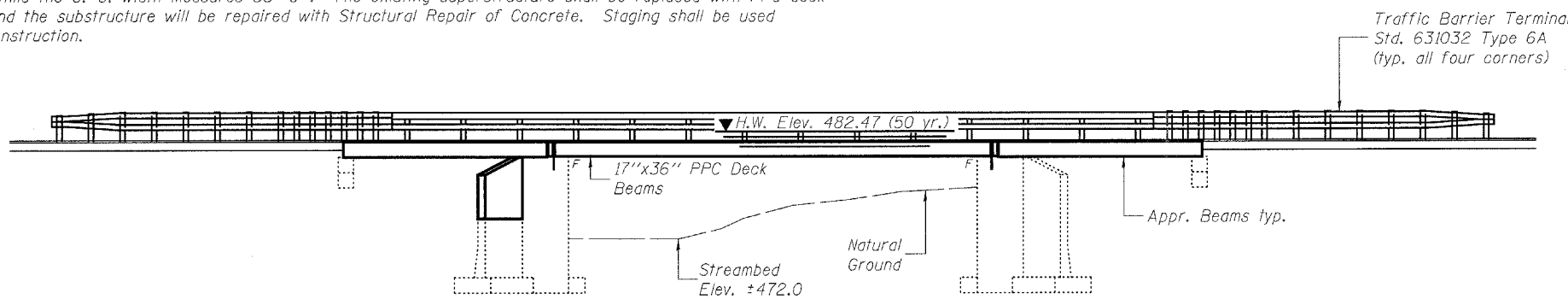

ELEVATION

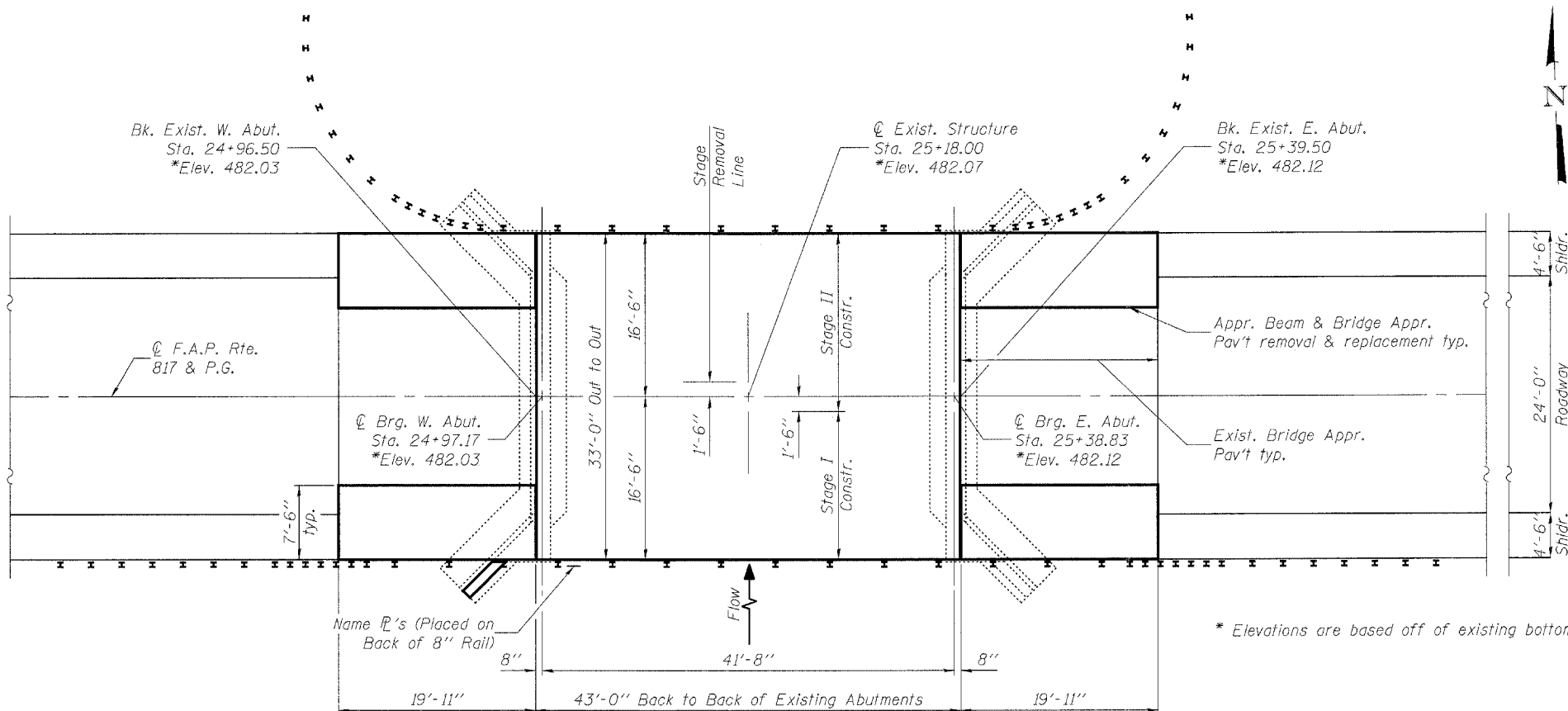

PLAN

LOADING HS20-44 (New Construction)

No Allowance for future wearing surface.

DESIGN SPECIFICATIONS (New Construction)

2002 AASHTO

DESIGN STRESSES

FIELD UNITS

$f'_c = 3,500$ psi
 $f_y = 60,000$ psi (reinforcement)

PRECAST PRESTRESSED UNITS

$f'_c = 5,000$ psi
 $f'_{ci} = 4,000$ psi
 $f'_s = 270,000$ psi ($\frac{1}{2}$ " ϕ low lax. strands)
 $f_{si} = 201,960$ psi ($\frac{1}{2}$ " ϕ low lax. strands)

STATION 25+18.00
RE-BUILT 200 BY
STATE OF ILLINOIS
FAP RT 817 - SEC 8BR-2
LOADING HS20
STR. NO. 095-0010

NAME PLATE

See Std. 515001

DESIGNED	EML
CHECKED	NJM
DRAWN	EML
CHECKED	NJM

HORNER & SHIFRIN, INC.
ENGINEERS ■ ARCHITECTS ■ PLANNERS



Eric Lagemann 6/21/06
Expires 11/30/2006

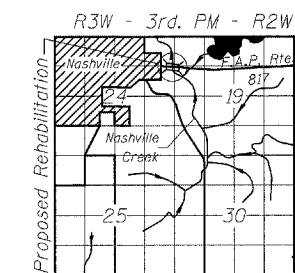

LOCATION SKETCH

GENERAL NOTES

Attach new Name Plate to the backside of 8" rail element. Existing Name Plate is to be removed, cleaned and relocated adjacent to new Name Plate. Cost included in the cost of Name Plates.

Repair of the abutments shall be completed prior to placement of the new deck beams.

The minimum thickness of Bituminous overlay shall be 2" and varies as required to adjust for the new profile grade and beam camber.

Plan dimensions and details relative to existing structure have been taken from existing plans and are subject to nominal construction variations. It shall be the Contractor's responsibility to verify such dimensions and details in the field and make necessary approved adjustments prior to construction or ordering of materials. Such variations shall not be cause for additional compensation for a change in the scope of the work, however, the Contractor will be paid for the quantity actually furnished at the unit price for the work.

The top surface of the beams shall be finished according to Article 504.06 of the Standard Specifications except that the surface shall not be roughened by brooming. The finished surface shall be free of depressions or high spots with sharp corners, and the top edge of keys shall be rounded or chamfered a minimum of $\frac{1}{4}$ ".

All Construction joints shall be bonded.

The cut strands at each beam end shall be given two coats of zinc dust spray or paint meeting the requirements of ASTM A 780. The zinc dust spray or paint shall be applied before corrosion appears and allowed to dry according to the manufacturer's specifications prior to another coat of zinc. A concrete sealer meeting the requirements of Section 587 of the Standard Specifications shall be applied to the exterior face and 9" in on the underside of the fascia beams. The sealer shall be applied after visible crack growth has subsided. This work shall be performed by the producer and included with the cost of the beam.

The contractor is advised that the existing Precast Prestressed Concrete Deck Beams are in a deteriorated condition with reduced load carrying capacity. It is the contractor's responsibility to account for the condition of the beams when developing construction procedures for removal and replacement of the superstructure.

TOTAL BILL OF MATERIAL

ITEM	UNIT	SUPER	SUB	TOTAL
Bridge Approach Pavement (Special)	Sq. Yd.		66	66
Removal of Existing Superstructures	Each	1		1
Concrete Removal	Cu. Yd.		10.1	10.1
Concrete Structures	Cu. Yd.		0.9	0.9
Precast Prestressed Concrete Deck Beams (17" Depth)	Sq. Ft.	1414		1414
Reinforcement Bars, Epoxy Coated	Pound		40	40
Steel Bridge Rail, Type SM	Foot	126		126
Name Plates	Each	1		1
Expansion Bolts $\frac{3}{4}$ Inch	Each		112	112
Waterproofing Membrane System	Sq. Yd.	158		158
Portland Cement Mortar Fairing Course	Foot	428		428
Removal of Existing Precast Concrete Units	Sq. Ft.	299		299
Structural Repair of Concrete (Depth Equal to or less than 5")	Sq. Ft.		14.0	14.0
Bituminous Concrete Surface Course Superpave, Mix "C", N70	Ton	23		23

GENERAL PLAN
ILLINOIS ROUTE 15 OVER
NASHVILLE CREEK
F.A.P. ROUTE 817 - SECTION 8BR-2
WASHINGTON COUNTY
STATION 25+18.00
STRUCTURE NO. 095-0010

STATE OF ILLINOIS
DEPARTMENT OF TRANSPORTATION

ROUTE NO.	SECTION	COUNTY	TOTAL SHEETS	SHEET NO.	SHEET NO. 2 10 SHEETS
F.A.P. 817	8BR-2, 8BR-3	WASHINGTON	52	21	
FED. ROAD DIST. NO. 7	ILLINOIS	FED. AID PROJECT			

Contract #76946

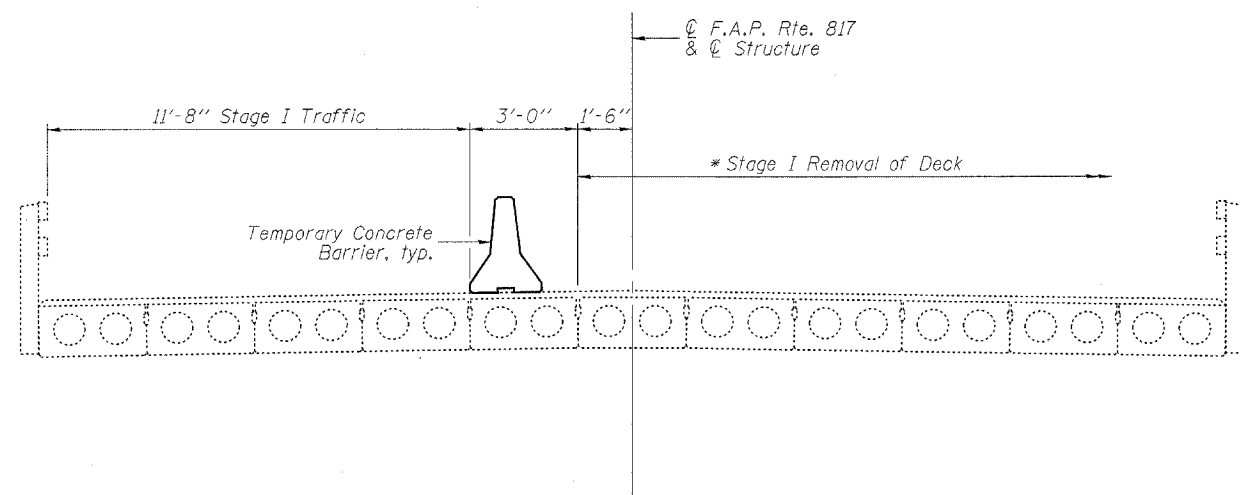

STAGE I REMOVAL

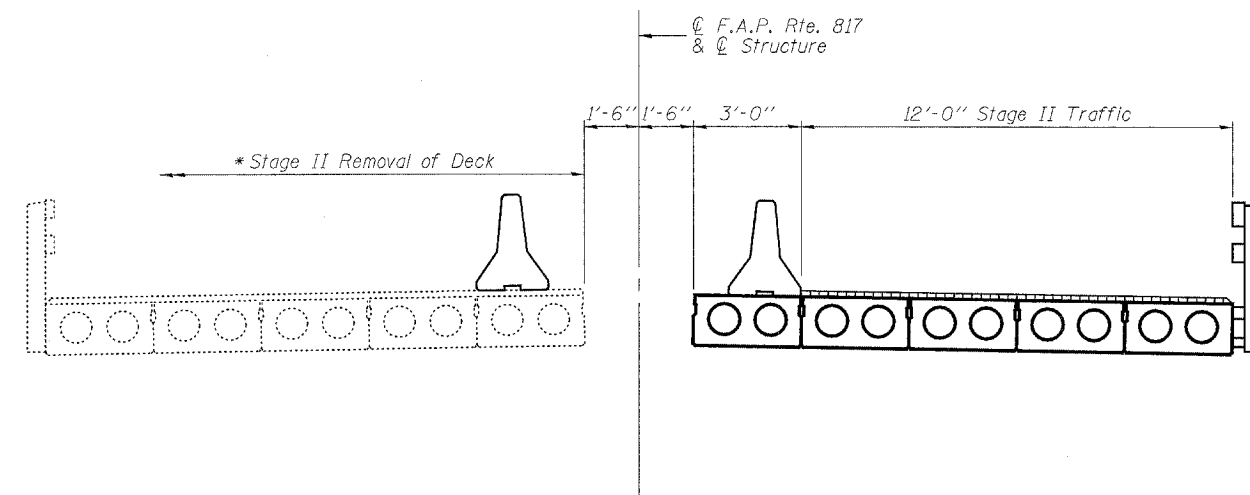

STAGE II REMOVAL

* The Contractor is required to brace the abutments at the beam seats longitudinally prior to the deck beam removal process. The braces shall stay in place until all new deck beams are doweled into position. This is to prevent the development of excessive stresses in the abutments during construction. Bracing details and computations are to be submitted to the Engineer for approval. The cost is included in Removal of Existing Superstructures.

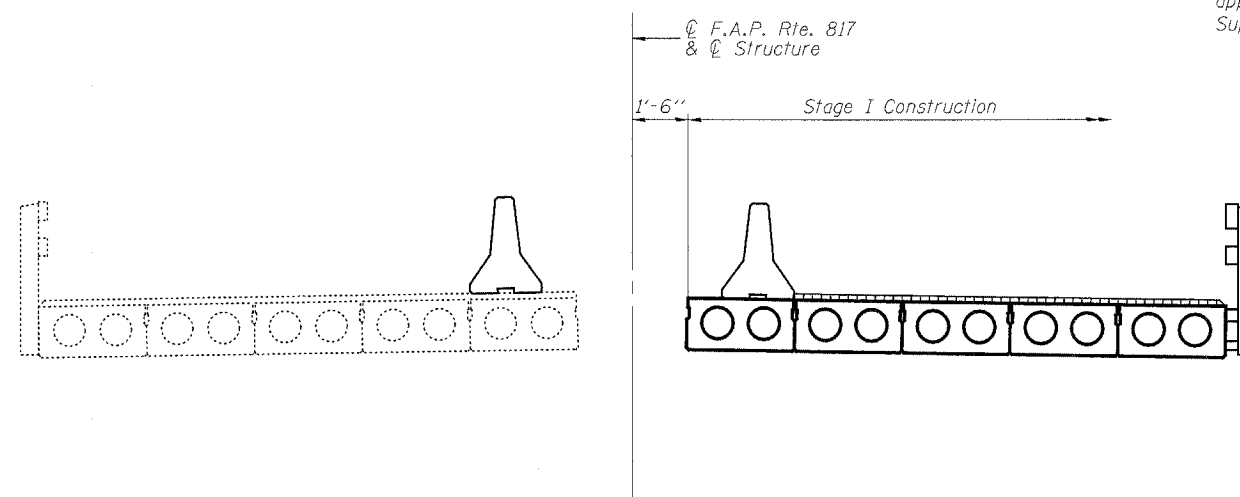

STAGE I CONSTRUCTION

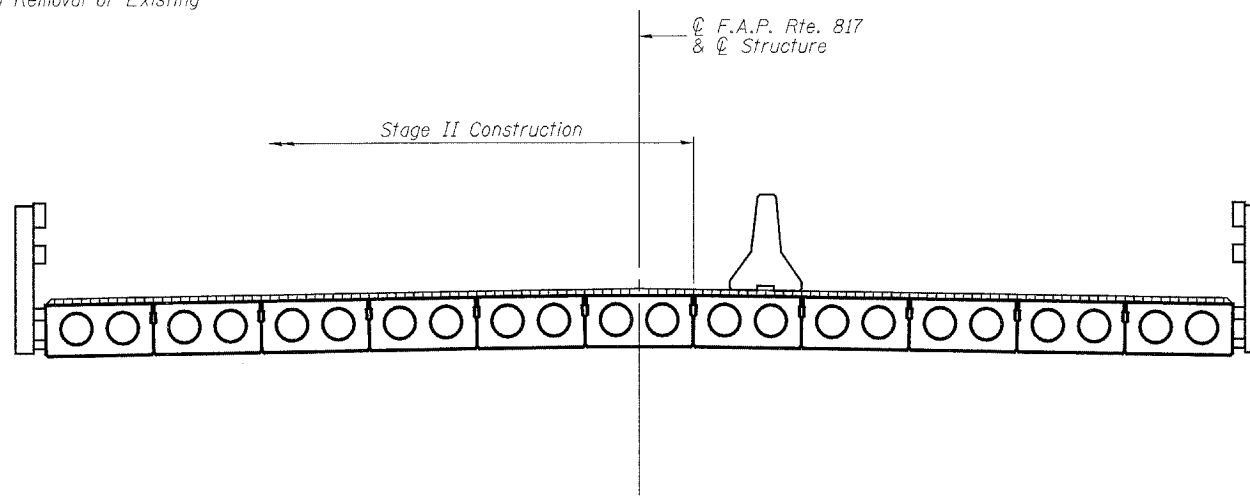

STAGE II CONSTRUCTION

Notes:
All sections are looking East.
For quantity of Temporary Concrete Barrier, see roadway plans.
For details of Temporary Concrete Barrier, see sheet 3 of 10.
For requirements for lapping waterproofing membrane, see notes on sheet 3 of 10.

DESIGNED	EML
CHECKED	NJM
DRAWN	EML
CHECKED	NJM



STAGE CONSTRUCTION DETAILS
F.A.P. ROUTE 817 - SECTION 8BR-2
WASHINGTON COUNTY
STATION 25+18.00
STRUCTURE NO. 095-0010

STATE OF ILLINOIS
DEPARTMENT OF TRANSPORTATION

ROUTE NO.	SECTION	COUNTY	TOTAL SHEETS	SHEET NO.	SHEET NO. 3 10 SHEETS
F.A.P. 817	8BR-2, 8BR-3	WASHINGTON	52	22	
FED. ROAD DIST. NO. 7	ILLINOIS	FED. AID PROJECT-			

Contract #76946

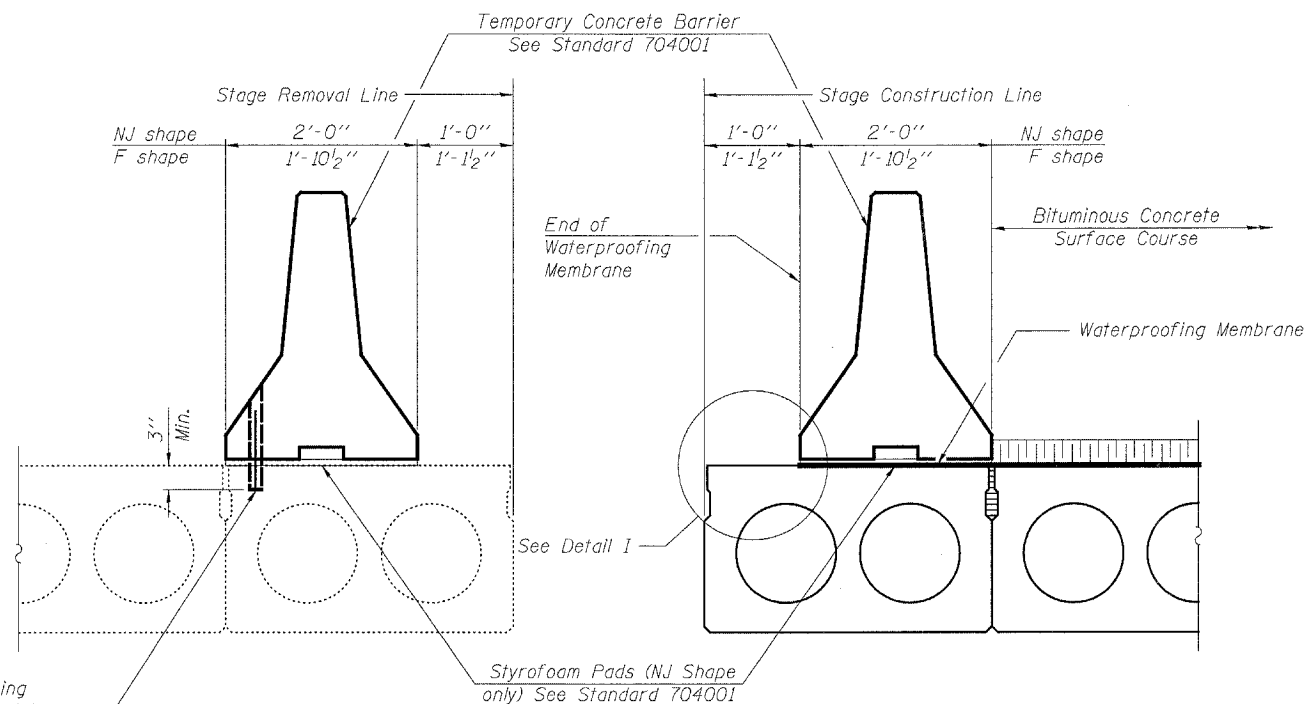

Drill 1/4" ϕ Holes in existing beam for 1" ϕ x 10" dowel bars. Traffic side only. Cost included with Temporary Concrete Barrier.

EXISTING PPC DECK BEAMS

NEW PPC DECK BEAMS

SECTIONS THRU PPC DECK BEAMS

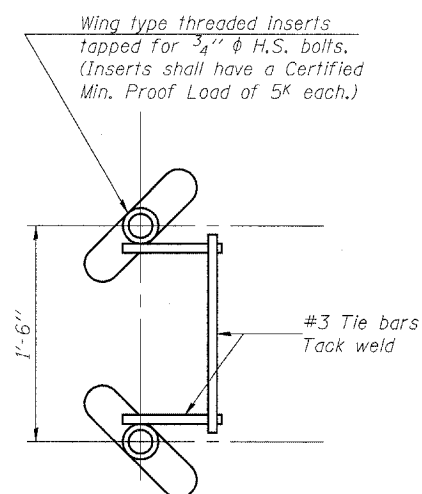

INSERT DETAIL

2 - Wing type threaded inserts for 3/4" ϕ H.S. bolts with flat hardened washer. Grout holes after removal.

Wood Blocks

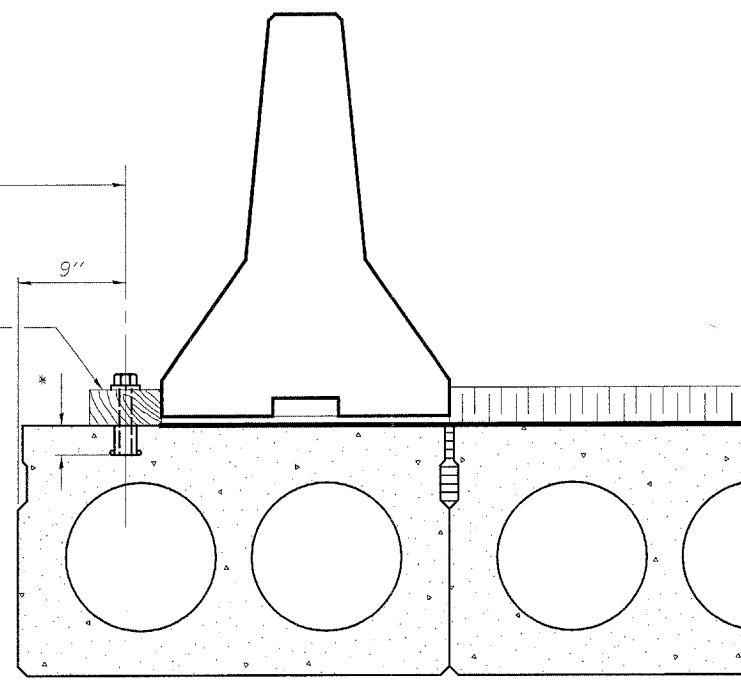

DETAIL I

The Temporary Concrete Barrier and wood blocks shall not be removed until Stage II Construction PPC Deck Beams have been placed and shear keys grouted.

NOTES

- The 3/4" ϕ high strength bolts used to connect the wood blocks shall be tightened to a snug fit without crushing the wood block.
- The wing type threaded insert assembly shall be spaced 6'-0" longitudinally.
- The Waterproofing Membrane shall extend under the Temporary Concrete Barrier without the asphalt sand seal protection layer. Once the Temporary Concrete Barrier has been removed, and the penetrating primer, coal tar emulsion, coal tar emulsion and fiberglass fabric, and coal tar emulsion slurry layers of the Waterproofing Membrane is lapped 6", the asphalt sand seal protection layer shall be applied according to Article 581 of the Standard Specifications.
- The cost for H.S. bolts, flat headed washers, and wood block is included with Temporary Concrete Barrier.
- The cost for wing type threaded inserts is included with Precast Prestressed Concrete Deck Beams (17" Depth).

DESIGNED	EML
CHECKED	NJM
DRAWN	EML
CHECKED	NJM

HORNER & SHIFRIN, INC.
ENGINEERS ■ ARCHITECTS ■ PLANNERS

**TEMPORARY CONCRETE BARRIER
FOR STAGE CONSTRUCTION
F.A.P. ROUTE 817 - SECTION 8BR-2
WASHINGTON COUNTY
STATION 25+18.00
STRUCTURE NO. 095-0010**

STATE OF ILLINOIS
DEPARTMENT OF TRANSPORTATION

ROUTE NO.	SECTION	COUNTY	TOTAL SHEETS	SHEET NO.	SHEET NO. 4
F.A.P. 817	8BR-2, 8BR-3	WASHINGTON	52	23	10 SHEETS
FED. ROAD DIST. NO. 7	ILLINOIS	FED. AID PROJECT-			

Contract #76946

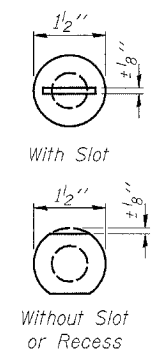
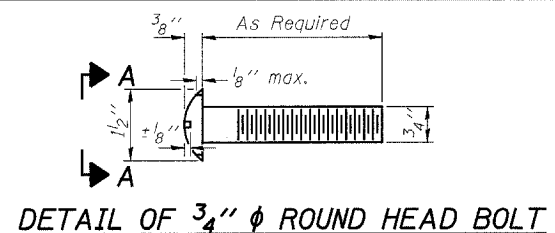

VIEW A-A

4-3/4" ϕ x 6" Round Head Bolts (With slot or approved recess in head) with locknut & flat washer. 7/8" ϕ holes in hollow structural section may be drilled in the field.

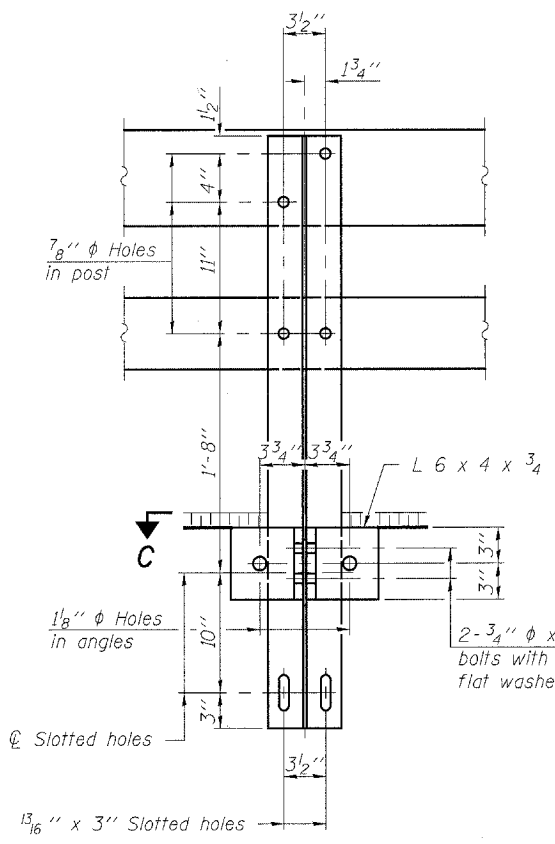

SECTION B-B

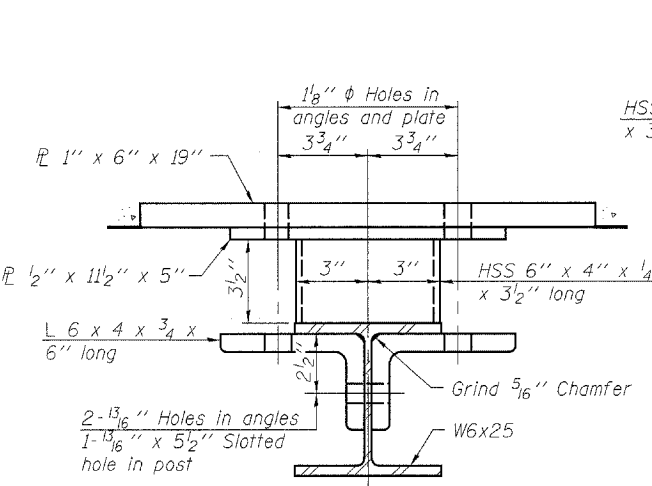

SECTION C-C

DESIGNED	EML
CHECKED	NJM
DRAWN	EML
CHECKED	NJM

HORNER & SHIFRIN, INC.
ENGINEERS ARCHITECTS PLANNERS

R-34BWS

10-28-05 (6'-3" Maximum Post Spacing) (1/4" minimum to 3/8" maximum BWS thickness)

RAIL SPLICE CONNECTION
AT EXPANSION JT.

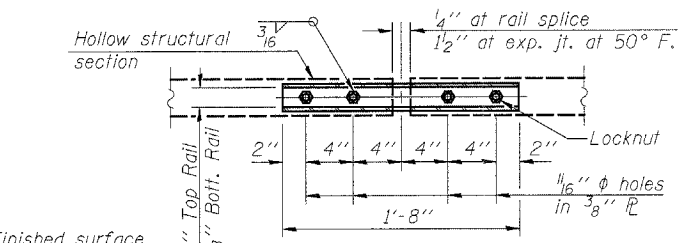
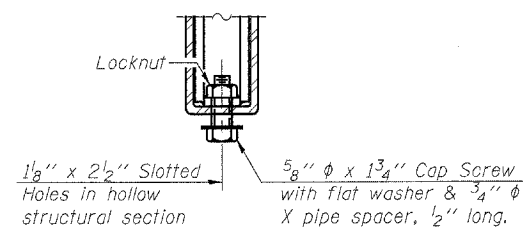

PLAN-BOTT. SPLICE R
TYPICAL

SECTION AT
RAIL SPLICE

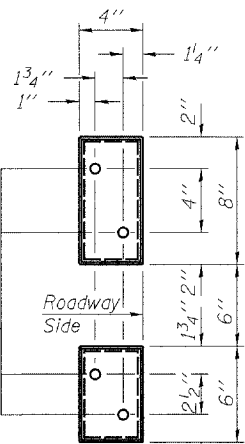

VIEW E-E

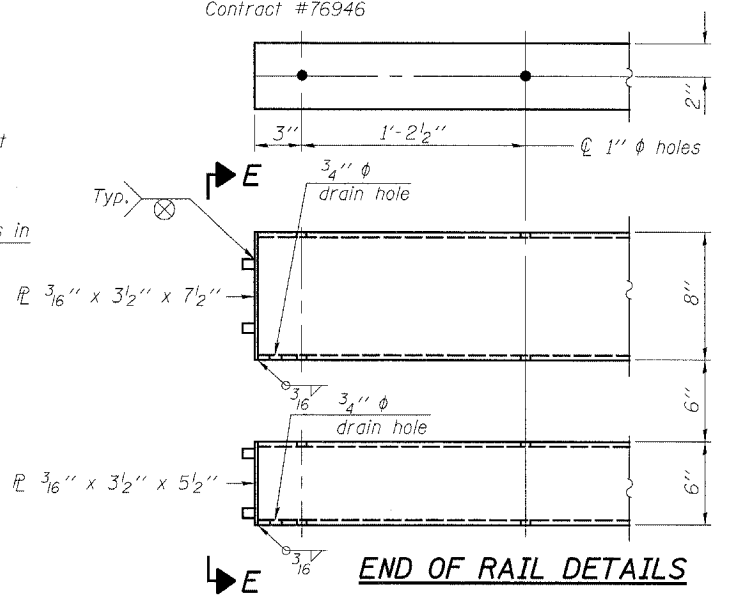

NOTES

Hollow structural sections shall conform to the requirements of ASTM designation A 500 Grade B Structural Steel Tubing and shall meet the longitudinal CVN requirements of 15 ft-lbs at 0° F. All other steel shapes and plates shall conform to the requirements of AASHTO M 270 Grade 36 except posts and angles shall conform to AASHTO M 270, Grade 50. Bolts, cap screws, and nuts shall conform to the requirements of ASTM designation A 307 except for high strength bolts, nuts and washers noted which shall conform to AASHTO M 164. All bolts, nuts, cap screws, washers and lock washers shall be galvanized according to AASHTO M 232. All posts, railing, rail splices, anchor devices and angles shall be galvanized after shop fabrication according to AASHTO M III and ASTM A 385. Galvanized rail shall not be painted. Railing shall be according to Section 509 of the Standard Specifications, except as noted, and will be paid for at the contract unit price per foot for Steel Bridge Rail, Type SM. All field drilled holes shall be coated with an approved zinc rich paint before erection. For multi-span bridges, sufficient 1/4" x 6" x 1'-2" galvanized steel shims shall be provided to align rail between adjacent spans. Cost included with Steel Bridge Rail, Type SM. The 3/4" ϕ high strength bolts used to connect the 6 x 4 x 3/4 angles to the post shall be tightened according to Article 505.04(f)(2) of the Standard Specifications. The 1" ϕ high strength bolts connecting the angles to the concrete shall be tightened to a snug fit and given an additional 1/8 turn. The 5/8" ϕ cap screws in bottom of posts shall be tightened to a snug fit only. For rail post spacing, see sheet 5 and 6 of 10.

BILL OF MATERIAL

Item	Unit	Quantity
Steel Bridge Rail, Type SM	Foot	126

TYPE SM
STEEL BRIDGE RAIL SIDE MOUNTED
F.A.P. ROUTE 817 - SECTION 8BR-2
WASHINGTON COUNTY
STATION 25+18.00
STRUCTURE NO. 095-0010

* Threaded areas shall be plugged or blocked off during casting of beam. Galvanized after fabrication.

** Whenever the lower insert assemblies interfere with strand locations, the #3 bars shall be cut and adjusted in order to allow raising or lowering of the lower inserts. Maximum adjustment not to exceed 1/2".

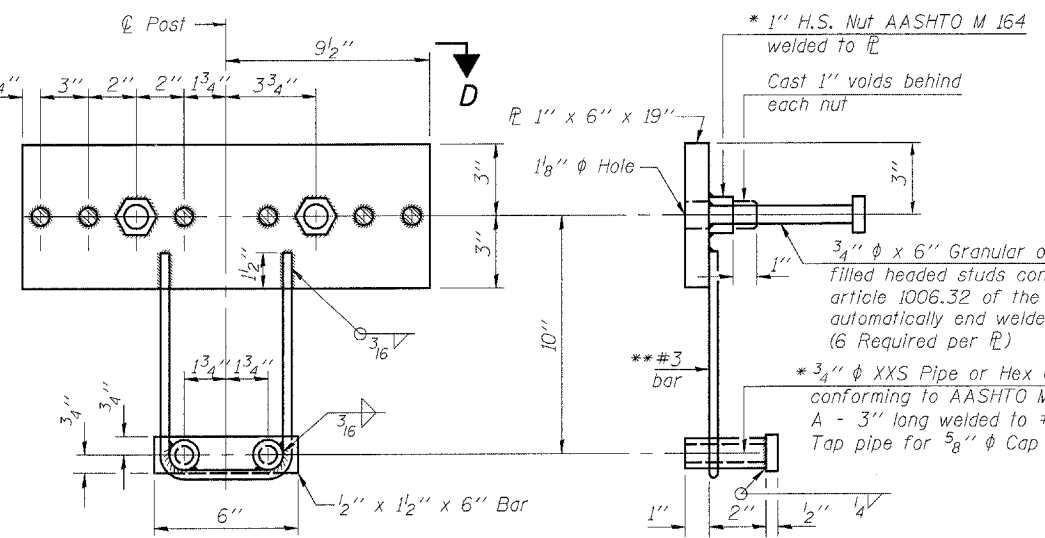

ANCHOR DEVICE

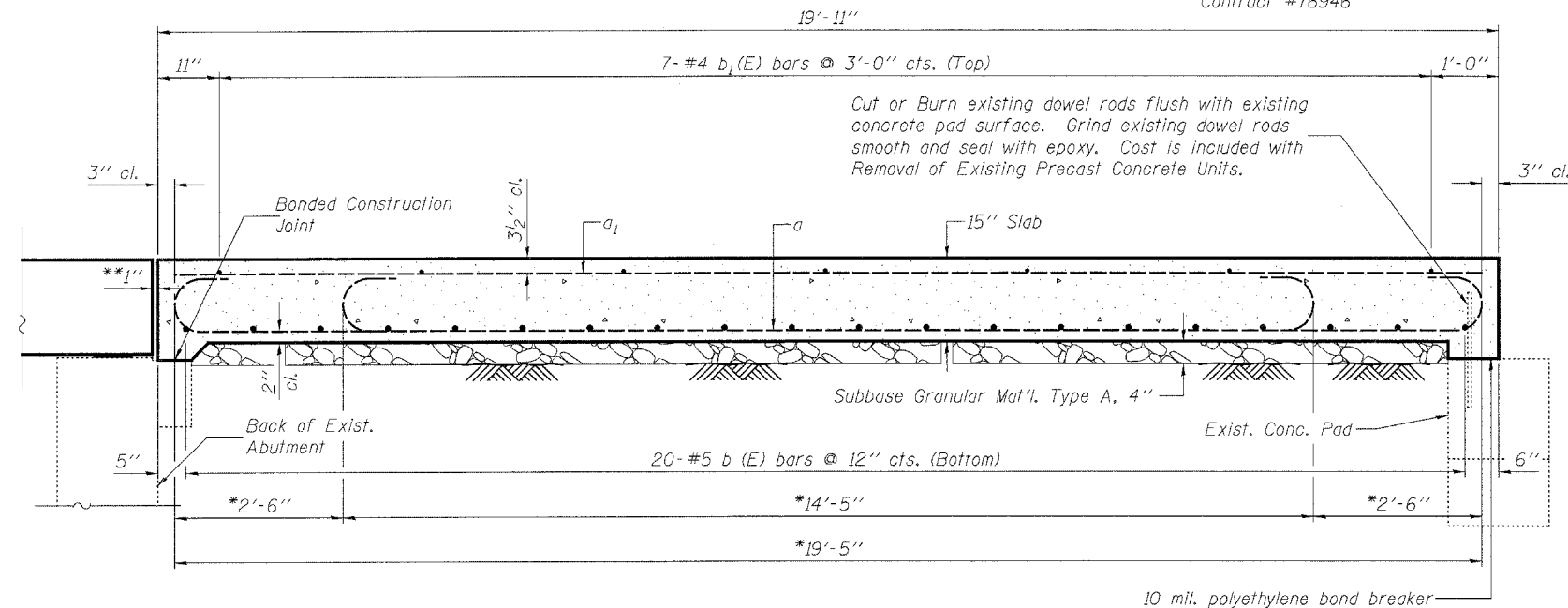
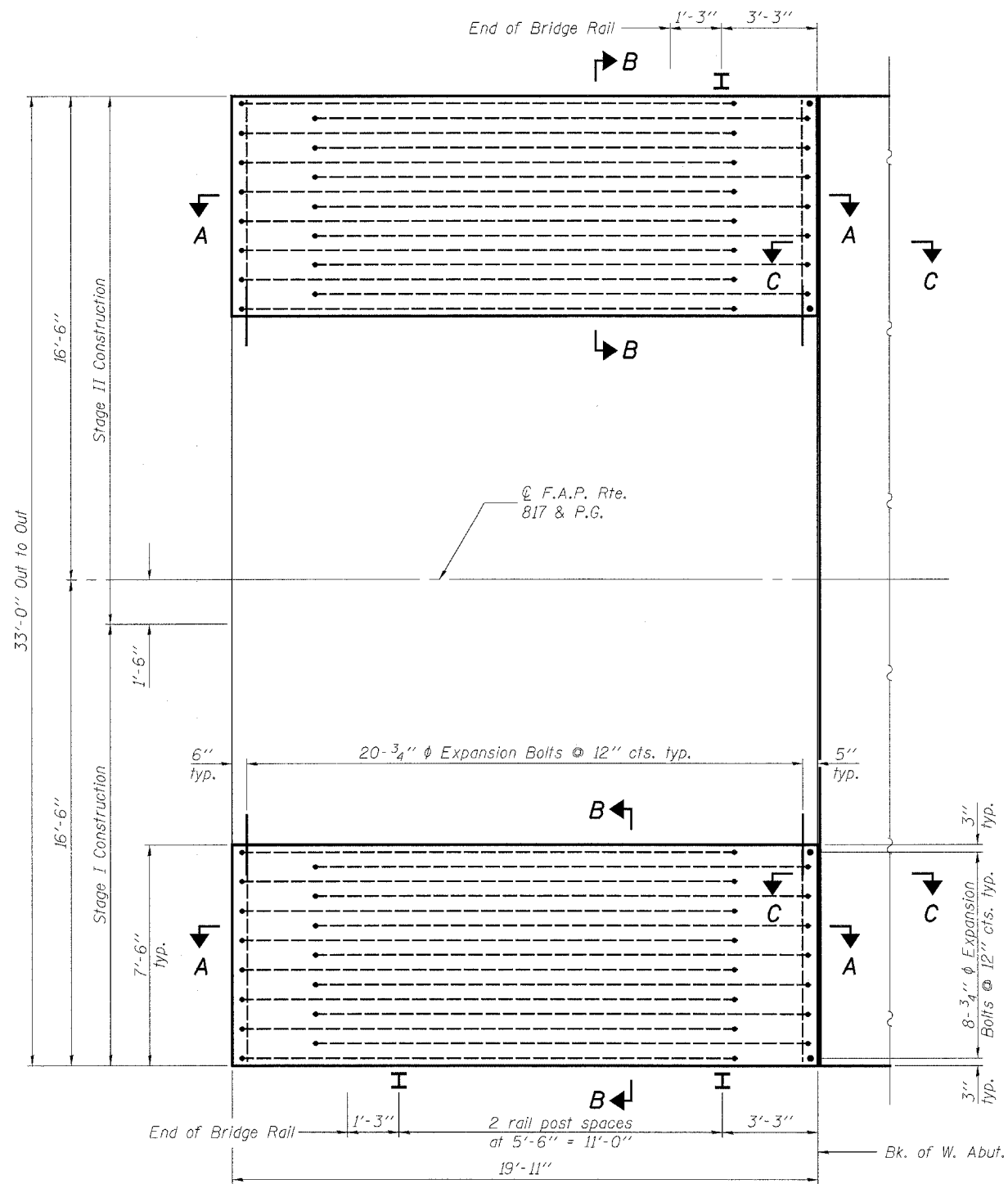

* Stagger No. 9 a bars as shown on plan.
**1" Jt. shall be filled with non-shrink grout. 1" dimension may vary to accommodate tolerance in Precast Prestressed Concrete Deck Beam lengths.

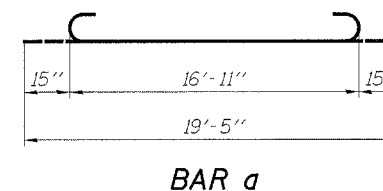
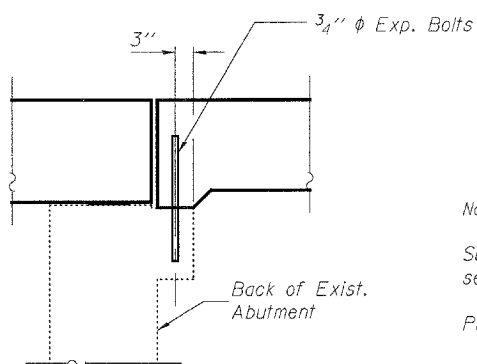
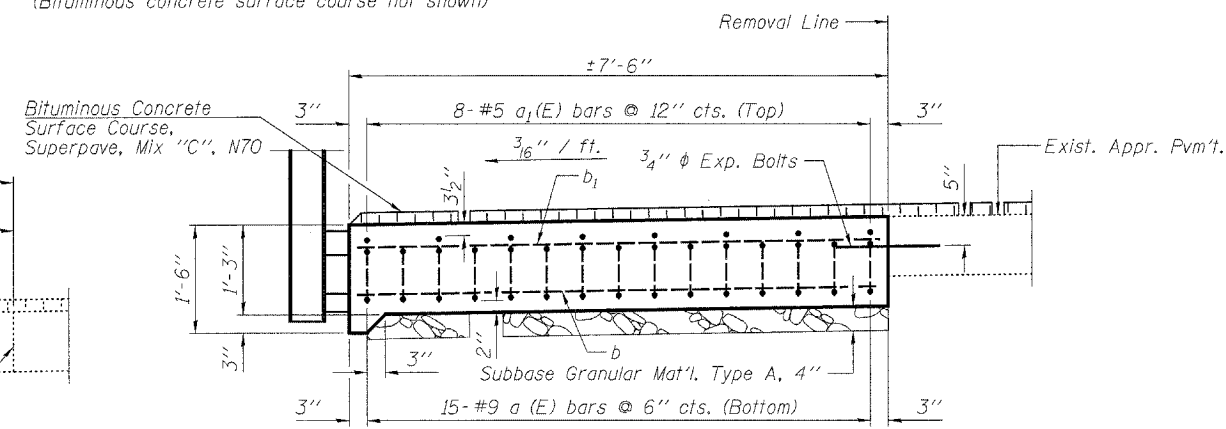
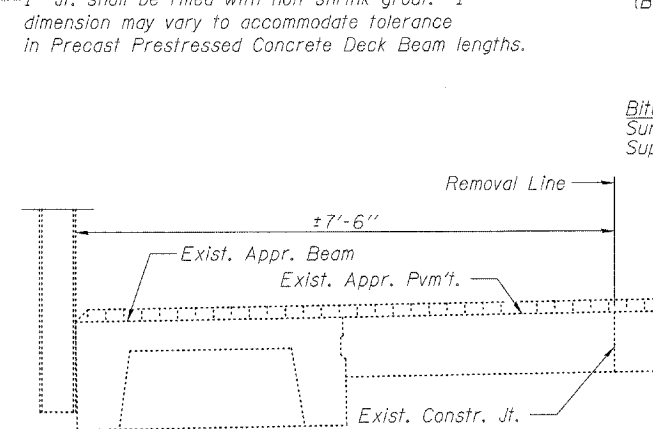

BAR LIST

Bar	No.	Size	Length	Shape
a(E)	60	#9	19'-5"	U
a ₁ (E)	32	#5	19'-5"	—
b(E)	80	#5	7'-3"	—
b ₁ (E)	28	#4	7'-3"	—

BILL OF MATERIAL

Item	Unit	Total
Bridge Approach Pavement (Special)	Sq. Yd.	66
Concrete Removal	Cu. Yd.	9.2
Expansion Bolts 3/4 Inch	Each	112
Removal of Existing Precast Concrete Units	Sq. Ft.	299

Notes:
For quantity of Bituminous Surface Removal and Bituminous Concrete Surface Course, Superpave, Mix "C", N70 on the bridge approach pavement, see roadway plans.
Removal of existing approach beams is included in Removal of Existing Precast Concrete Units.
Removal of existing approach pavement is included with Concrete Removal, Concrete Removal, Removal of Existing Precast Concrete Units and Bridge Approach Pavement (Special) shall occur during its respective stage construction and prior to placement of the new deck beams.
See Special Provisions for Bridge Approach Pavement (Special).
See sheet 4 of 10 for rail anchor device to be cast in approach beams.

BRIDGE APPROACH PAVEMENT (SPECIAL)
F.A.P. ROUTE 817 - SECTION 8BR-2
WASHINGTON COUNTY
STATION 25+18.00
STRUCTURE NO. 095-0010

DESIGNED	EML
CHECKED	NJM
DRAWN	EML
CHECKED	NJM

HORNER & SHIFRIN, INC.
ENGINEERS ■ ARCHITECTS ■ PLANNERS

STATE OF ILLINOIS
DEPARTMENT OF TRANSPORTATION

ROUTE NO.	SECTION	COUNTY	TOTAL SHEETS	SHEET NO.	SHEET NO. 6 10 SHEETS
F.A.P. 817	8BR-2, 8BR-3	WASHINGTON	52	25	
FED. ROAD DIST. NO. 7	ILLINOIS	FED. AID PROJECT			

Contract #76946

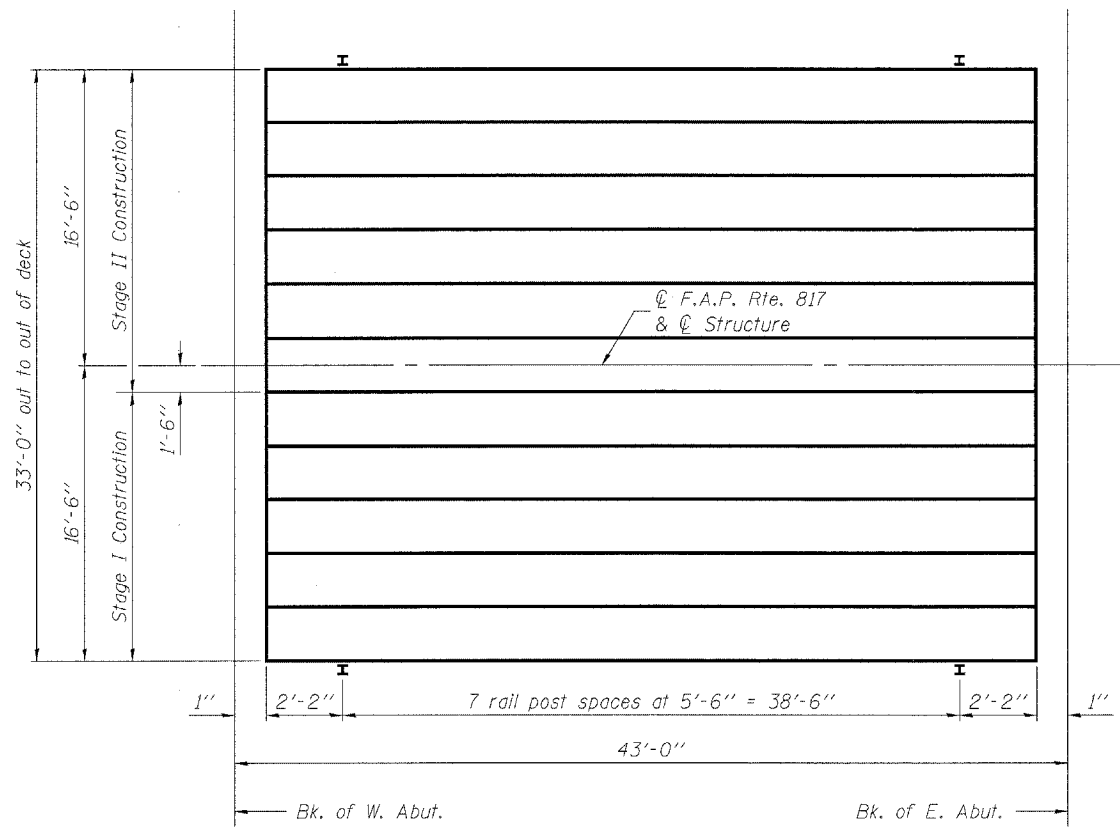

PLAN

Notes:
Rail spacing the same on both sides of the bridge.
See sheet 5 of 10 for end of bridge rail location.

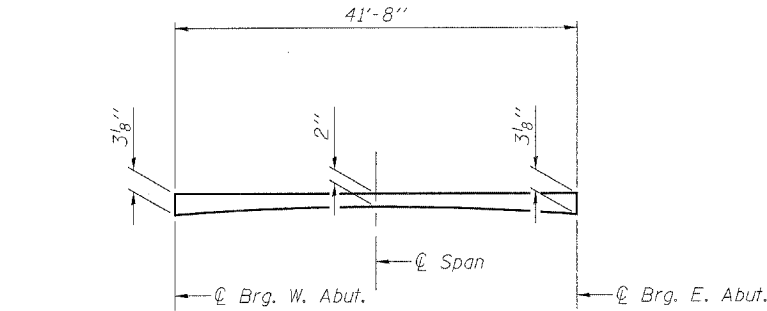

BITUMINOUS CONCRETE SURFACE COURSE PROFILE

(Bituminous concrete surface course along edge of beams)

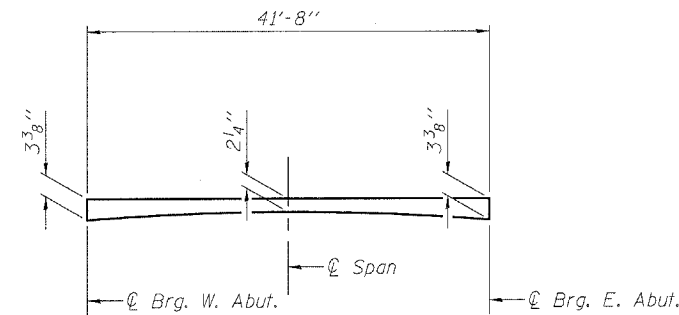

BITUMINOUS CONCRETE SURFACE COURSE PROFILE

(Bituminous concrete surface course along roadway)

Note:
Bituminous Concrete Surface Course Profile dimensions include 1/2" for waterproofing membrane thickness.

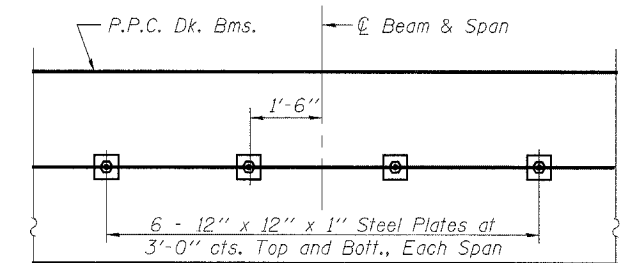

PLAN

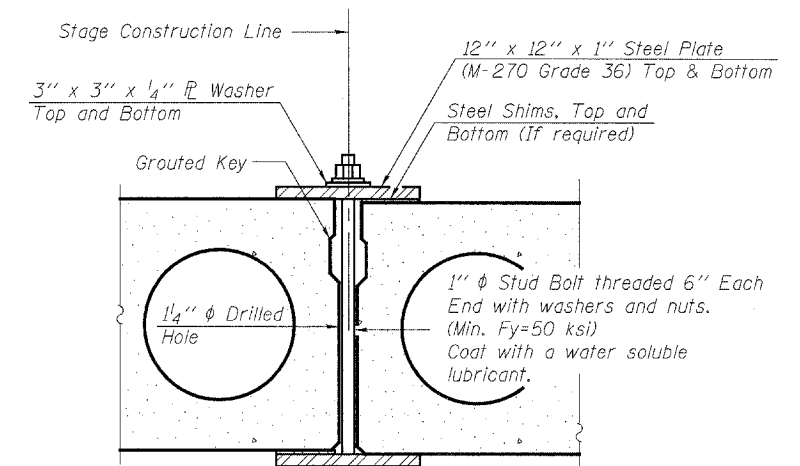

SECTION

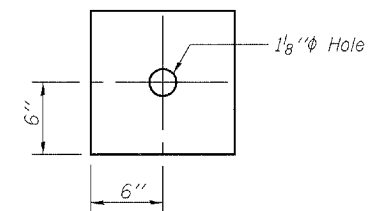

CLAMPING PLATE

SHEAR KEY CLAMPING DETAILS AT STAGE CONST. JT.

See Special Provisions for Stage Construction of Precast Prestressed Concrete Deck Beams.
Cost included with "Precast Prestressed Concrete Deck Beams".
See Stage Construction Details for traffic lanes.

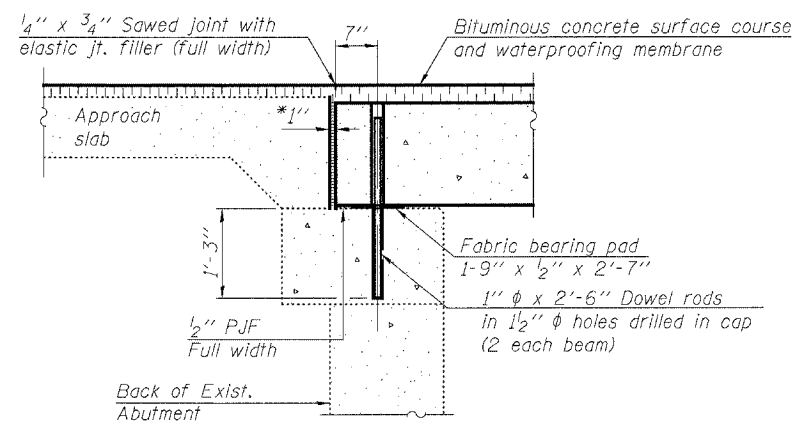

SECTION THRU ABUTMENT

* 1" Jt. shall be filled with non-shrink grout. 1" dimension may vary to accommodate tolerance in beam lengths.

Notes:
After beams have been erected, holes shall be drilled into substructure and anchor dowels placed. Dowel holes shall be filled with non-shrink grout to top of beam and allowed to cure min. 24 hrs. prior to grouting the shear keys.
All horizontal dimensions are at right angles to beam ends.
See sheet 7 of 10 for bearing pad details.

DESIGNED	EML
CHECKED	NJM
DRAWN	EML
CHECKED	NJM

HORNER & SHIFRIN, INC.
ENGINEERS ■ ARCHITECTS ■ PLANNERS

SUPERSTRUCTURE DETAILS
F.A.P. ROUTE 817 - SECTION 8BR-2
WASHINGTON COUNTY
STATION 25+18.00
STRUCTURE NO. 095-0010

STATE OF ILLINOIS
DEPARTMENT OF TRANSPORTATION

ROUTE NO.	SECTION	COUNTY	TOTAL SHEETS	SHEET NO.	SHEET NO. 7 10 SHEETS
F.A.P. 817	8BR-2, 8BR-3	WASHINGTON	52	26	
FED. ROAD DIST. NO. 7	ILLINOIS	FED. AID PROJECT-			

Contract #76946

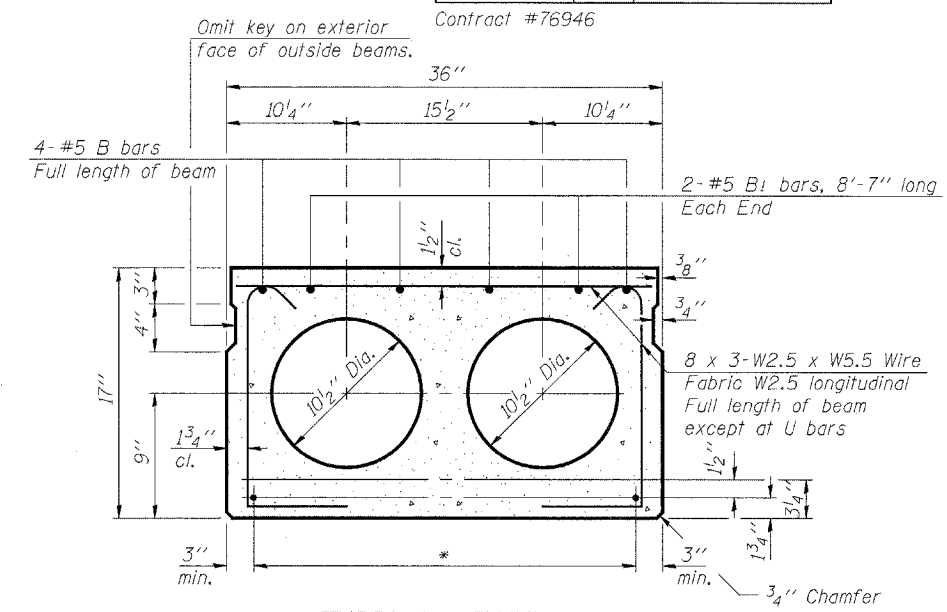
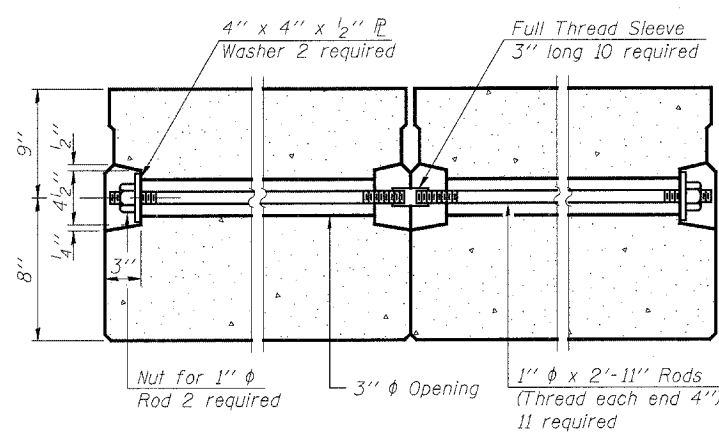
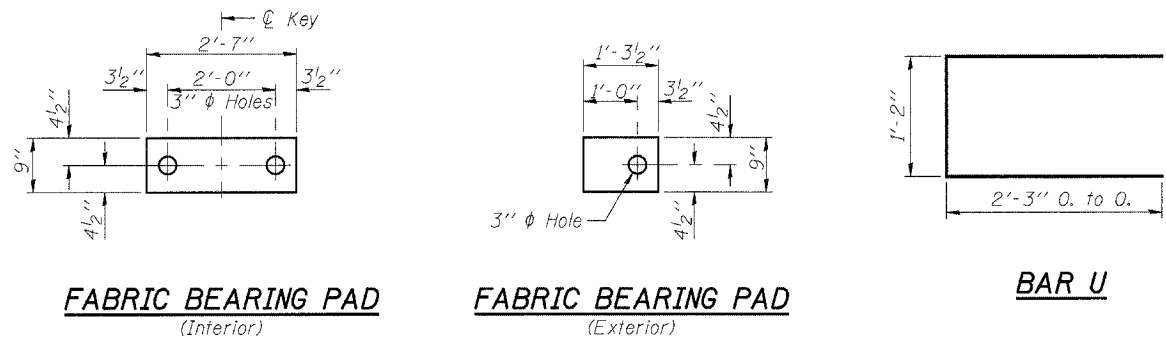

- *Transverse Strand Placement Guidelines**
1. Place strands symmetrically about centerline of beam.
 2. The minimum distance from center to center of strands in all directions shall be 2".
 3. The minimum clearance from strand to dowel hole shall be 1/2".
 4. The minimum clearance from strand to void shall be 1/2".

Vertical placement of strands shall not be adjusted to satisfy the above guidelines.

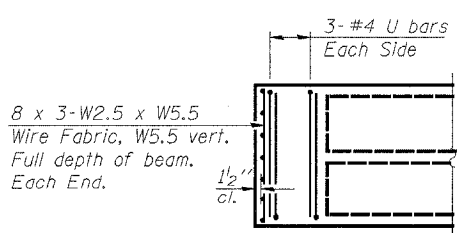
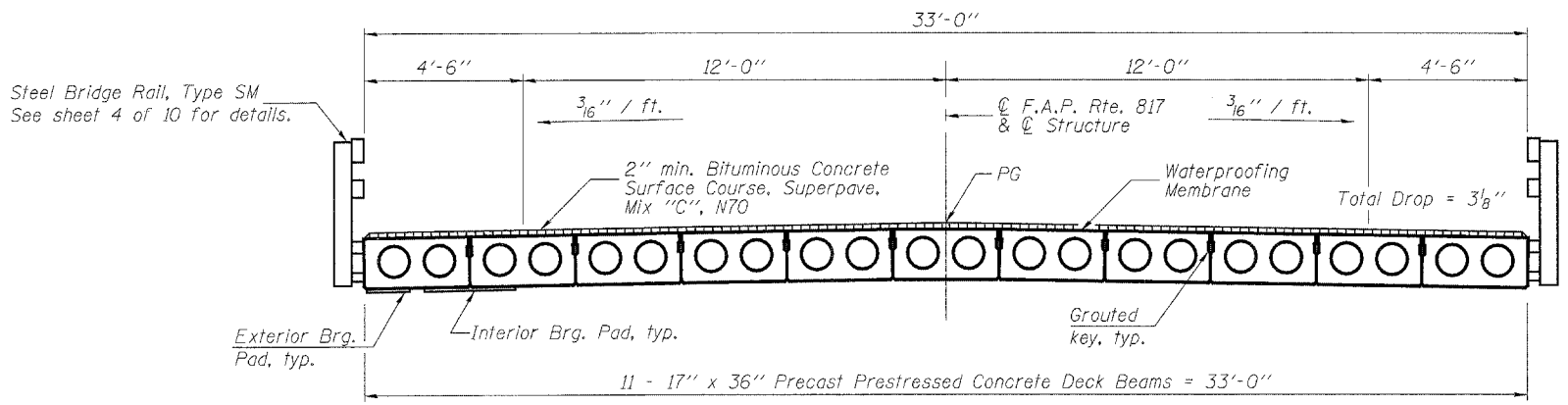
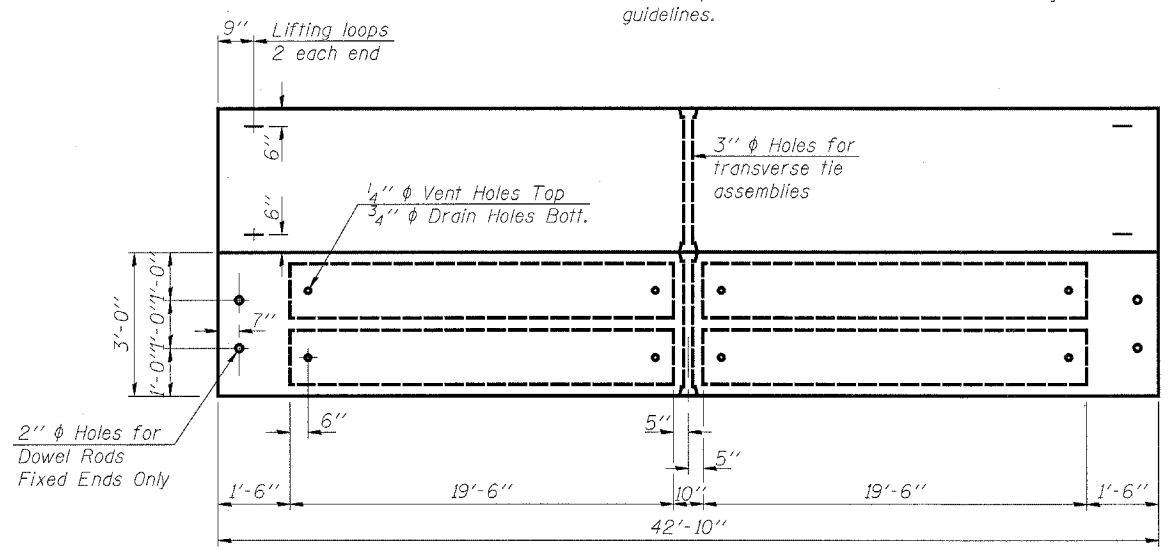

PLAN

END PLAN

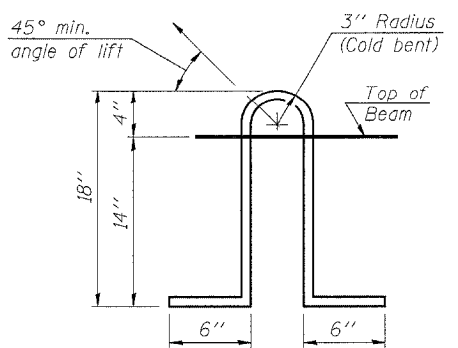

LIFTING LOOP DETAIL

NOTES

Prestressing steel shall be uncoated high strength, low relaxation 7-wire strand, Grade 270. The nominal diameter shall be 1/2" and the nominal cross-sectional area shall be 0.153 sq. in. Lifting loops shall be 2 - 1/2" phi-270 ksi strands, as shown.

The 1" phi rods in the transverse tie assembly shall be tightened to a snug fit and the threads set. Pockets that receive transverse tie bar on outside shall be filled with grout after transverse tie assembly is in place.

The bearing seat surfaces shall be adjusted by shimming to assure firm and even bearing. Two 1/8" fabric adjusting shims of the dimensions of the Exterior Bearing Pad shall be provided for each bearing.

Keyway surfaces shall be cleaned to remove form oil or other bond breaking material prior to shipment of the beams. Cleaning shall be done by sandblasting the keyway areas between top of the beam and the bottom edge of the key.

Corrosion Inhibitor, as covered in the Special Provisions, shall be used in the concrete for precast prestressed concrete deck beams.

Required Release Strength, f'ci, shall be 4,000 p.s.i.

See sheet 3 of 10 for Wing Type Threaded Insert location and spacing.

See sheet 4 of 10 for rail anchor device to be cast in precast beams.

See sheet 6 of 10 for spacing of rail post.

See sheet 6 of 10 for Shear Key Clamping Details at Stage Const. Jt.

BILL OF MATERIAL

Item	Unit	Total
Precast Prestressed Concrete Deck Beams (17" Depth)	Sq. Ft.	1414

SUPERSTRUCTURE DETAILS
F.A.P. ROUTE 817 - SECTION 8BR-2
WASHINGTON COUNTY
STATION 25+18.00
STRUCTURE NO. 095-0010

DESIGNED	EML
CHECKED	NJM
DRAWN	EML
CHECKED	NJM

HORNER & SHIFRIN, INC.
ENGINEERS ■ ARCHITECTS ■ PLANNERS

STATE OF ILLINOIS
DEPARTMENT OF TRANSPORTATION

ROUTE NO.	SECTION	COUNTY	TOTAL SHEETS	SHEET NO.	SHEET NO. 8 10 SHEETS
F.A.P. 817	8BR-2, 8BR-3	WASHINGTON	52	27	
FED. ROAD DIST. NO. 7	ILLINOIS	FED. AID PROJECT-			

Contract #76946

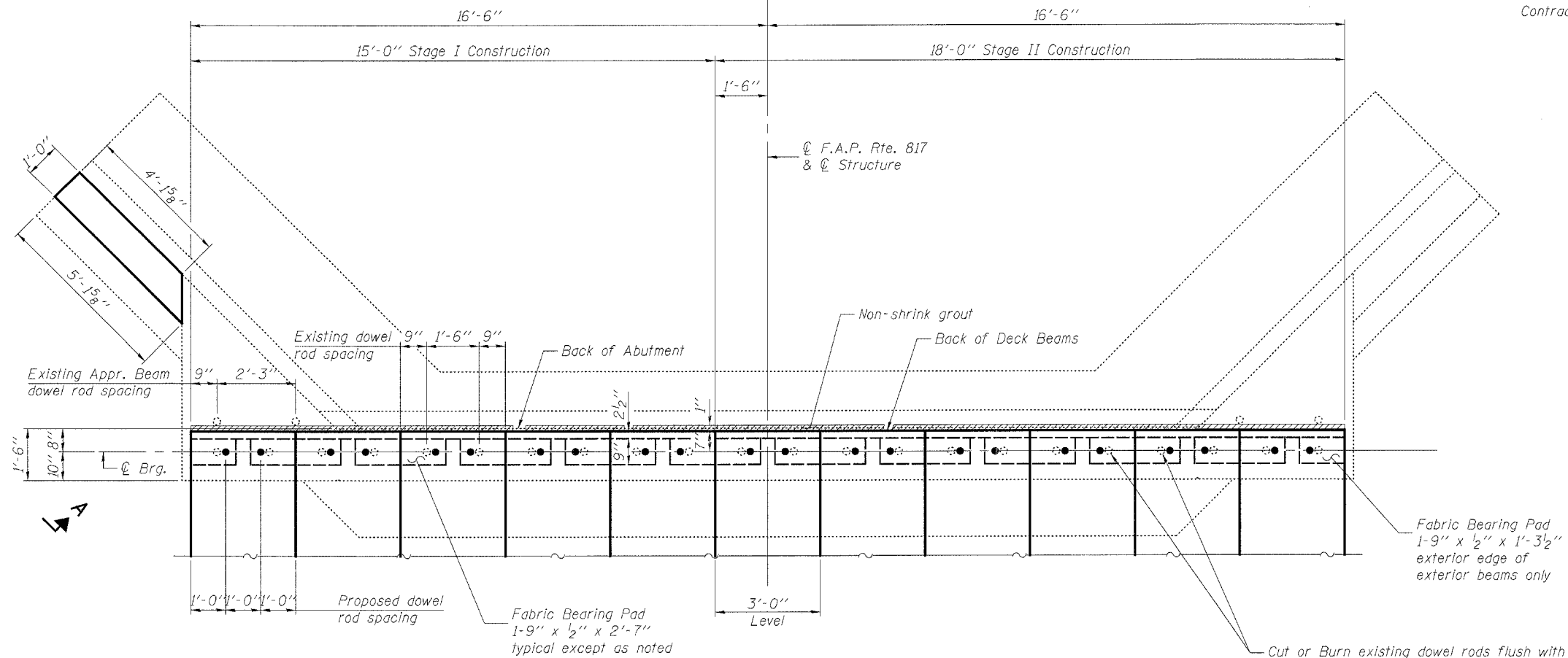

PLAN

(Bituminous concrete surface course not shown)

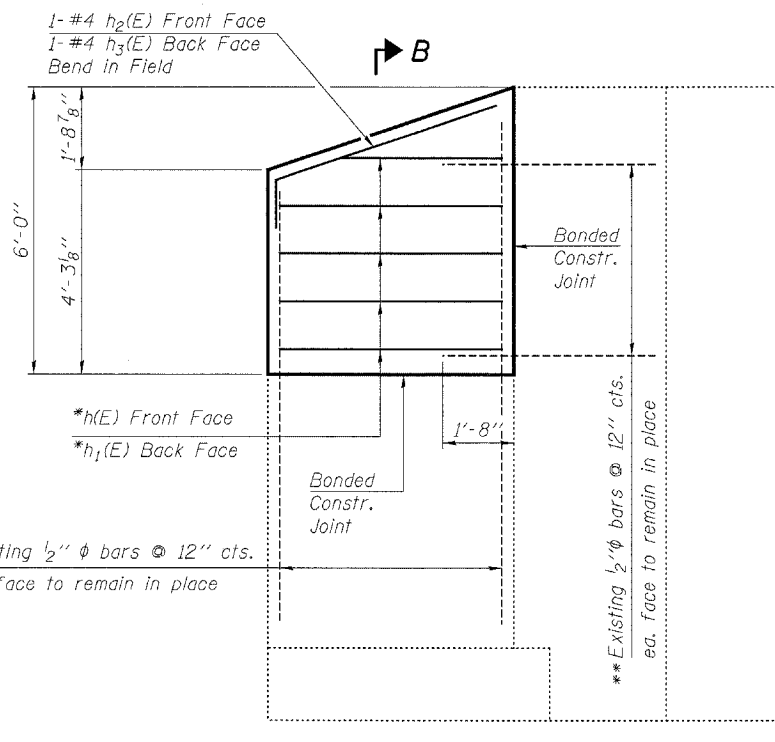

VIEW A-A

(Deck Beams, Approach Beams, Bituminous concrete surface course not shown)

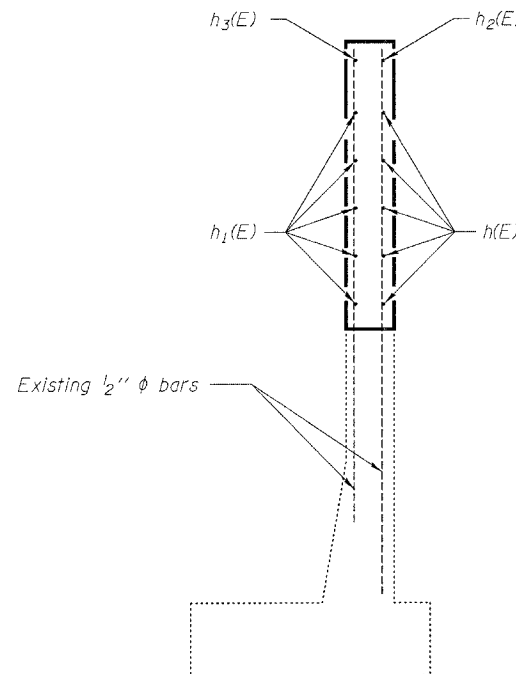

SECTION B-B

Notes:

Existing reinforcement bars extending into the removal area shall be cleaned, straightened and incorporated into the new construction. Any reinforcement bars that are damaged during concrete removal shall be replaced with an approved bar splicer or anchorage system. Cost included with Concrete Removal.
For Abutment Repair and Concrete Removal details see sheet 10 of 10.

BILL OF MATERIAL

Bar	No.	Size	Length	Shape
h(E)	5	#4	4'-8"	—
h ₁ (E)	5	#4	4'-0"	—
h ₂ (E)	1	#4	6'-0"	—
h ₃ (E)	1	#4	5'-3"	—
Reinforcement Bars, Epoxy Coated			Pound	40
Concrete Structures			Cu. Yd.	0.9

WEST ABUTMENT
F.A.P. ROUTE 817 - SECTION 8BR-2
WASHINGTON COUNTY
STATION 25+18.00
STRUCTURE NO. 095-0010

DESIGNED	EML
CHECKED	NJM
DRAWN	EML
CHECKED	NJM

HORNER & SHIFRIN, INC.
ENGINEERS ■ ARCHITECTS ■ PLANNERS

STATE OF ILLINOIS
DEPARTMENT OF TRANSPORTATION

ROUTE NO.	SECTION	COUNTY	TOTAL SHEETS	SHEET NO.	SHEET NO. 9 10 SHEETS
F.A.P. 817	8BR-2 8BR-3	WASHINGTON	52	28	
FED. ROAD DIST. NO. 7	ILLINOIS	FED. AID PROJECT			

Contract #76946

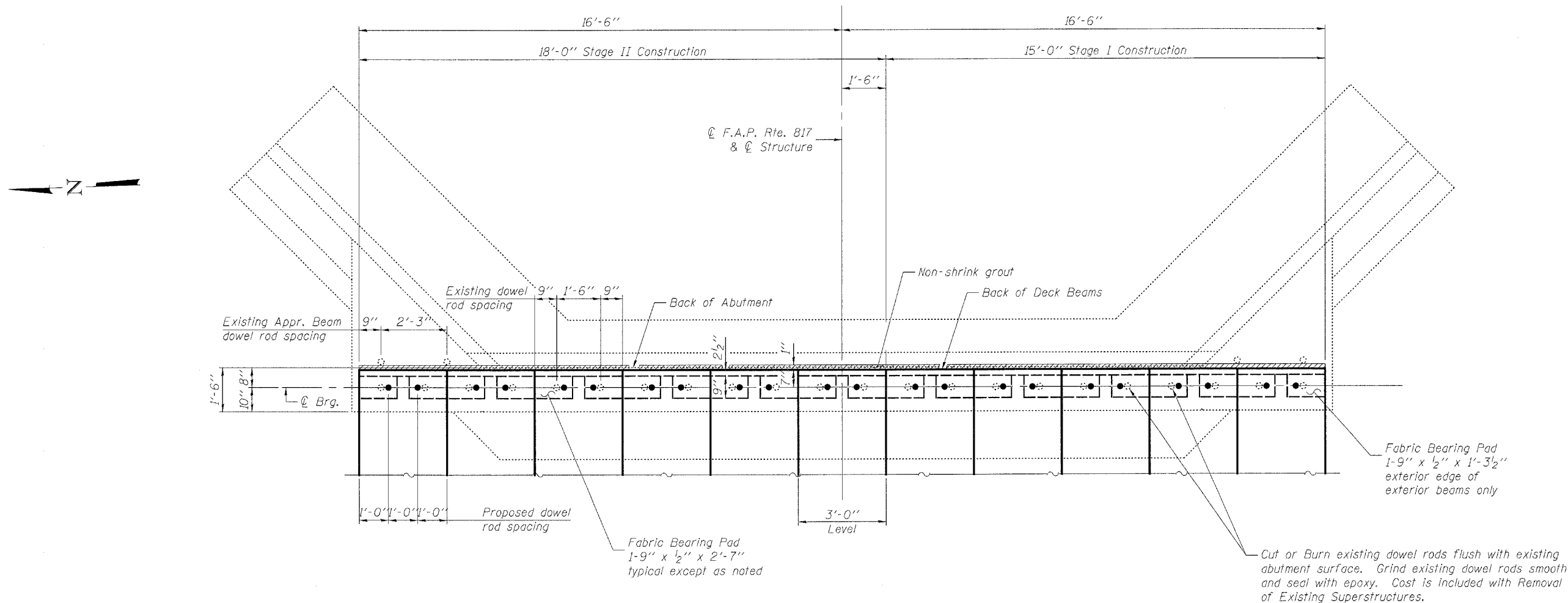

PLAN
(Bituminous concrete surface course not shown)

Notes:
For Abutment Repair details see sheet 10 of 10.

DESIGNED	EML
CHECKED	NJM
DRAWN	EML
CHECKED	NJM

HORNER & SHIFRIN, INC.
ENGINEERS ■ ARCHITECTS ■ PLANNERS

EAST ABUTMENT
F.A.P. ROUTE 817 - SECTION 8BR-2
WASHINGTON COUNTY
STATION 25+18.00
STRUCTURE NO. 095-0010

STATE OF ILLINOIS
DEPARTMENT OF TRANSPORTATION

ROUTE NO.	SECTION	COUNTY	TOTAL SHEETS	SHEET NO.	SHEET NO. 10
F.A.P. 817	8BR-2, 8BR-3	WASHINGTON	52	29	10 SHEETS
FED. ROAD DIST. NO. 7	ILLINOIS	FED. AID PROJECT-			

Contract #76946

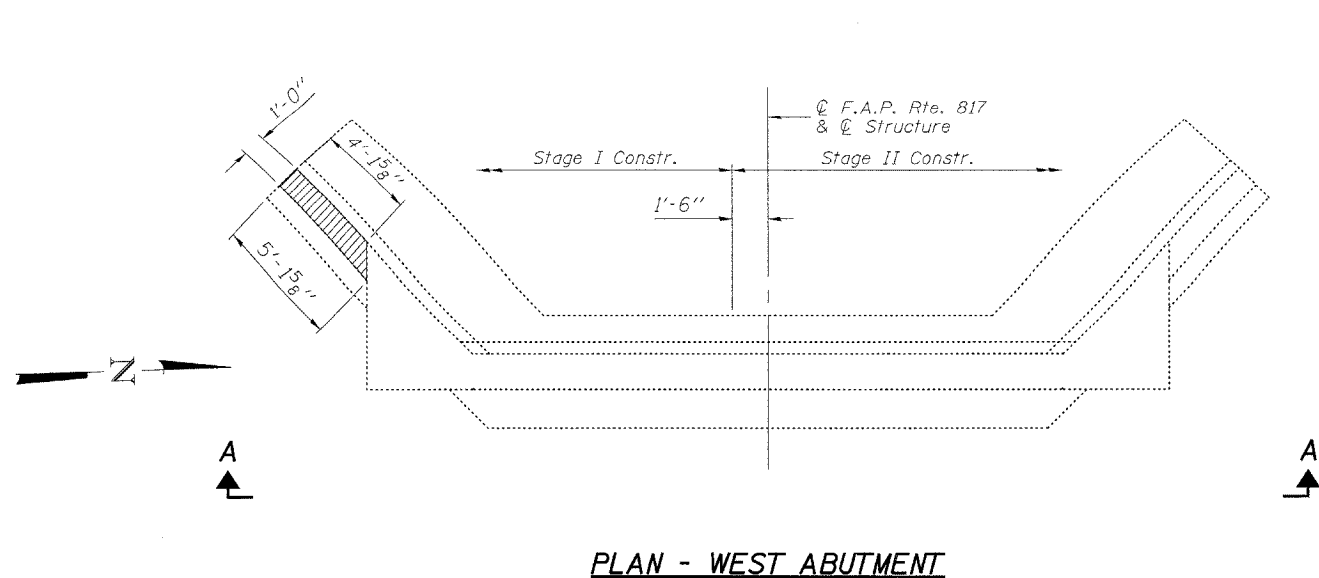

PLAN - WEST ABUTMENT

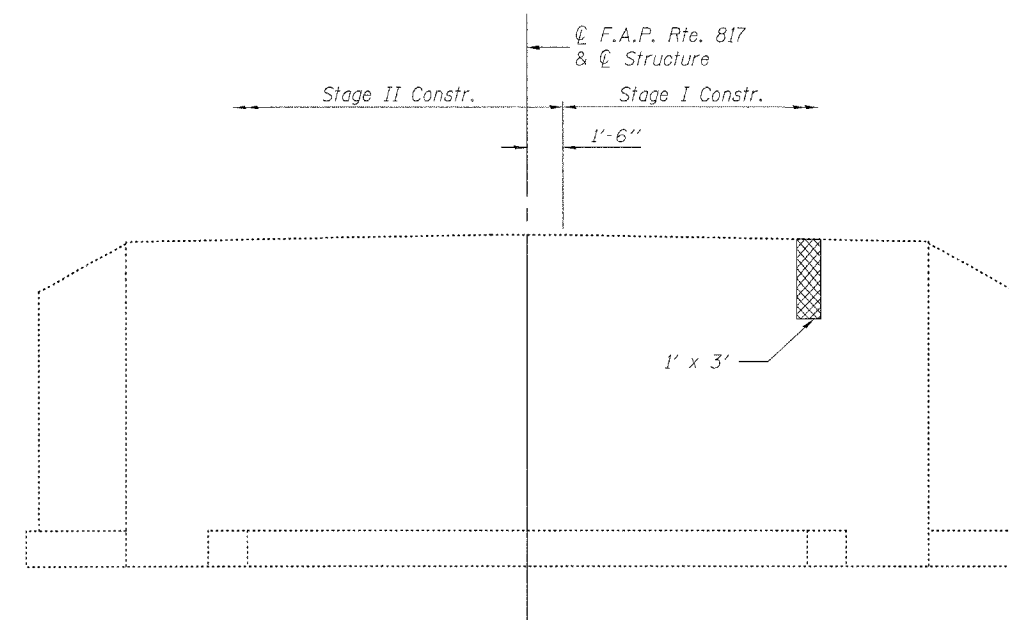

ELEVATION - EAST ABUTMENT
(Looking East)

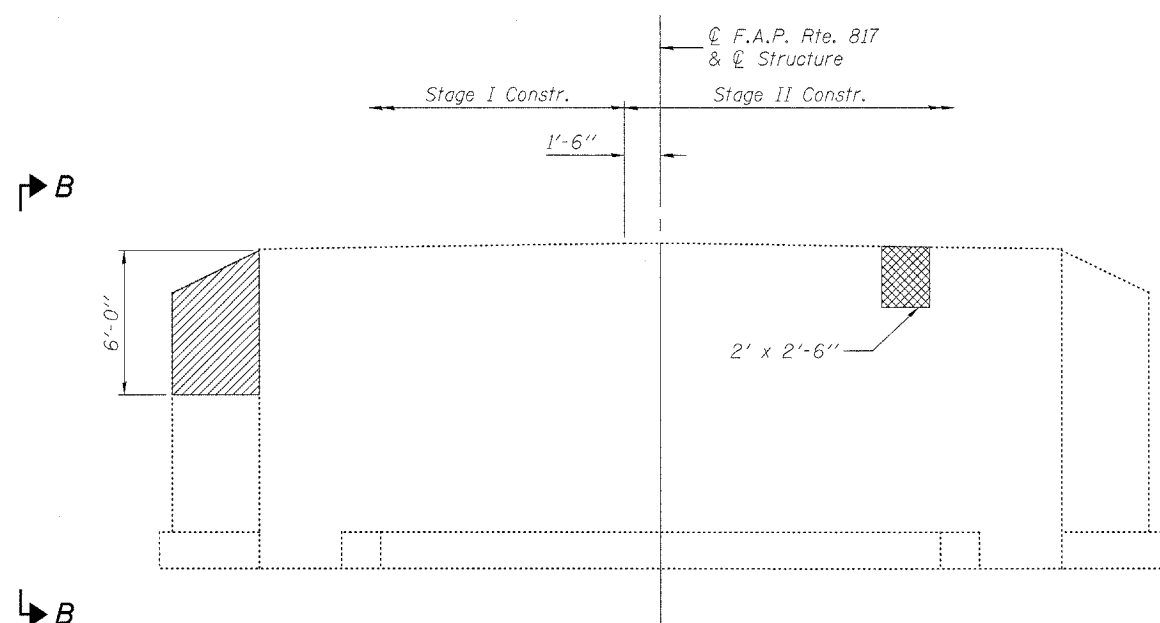

VIEW A-A

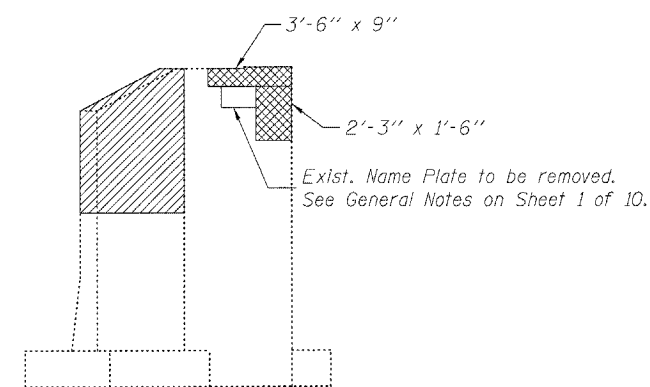

VIEW B-B

BILL OF MATERIAL

Item	Unit	Total
Concrete Removal	Cu. Yd.	0.9
Structural Repair of Concrete (Depth Equal to or less than 5")	Sq. Ft.	14.0

Notes:
Concrete Removal and Structural Repair of Concrete shall occur during its respective stage construction.
See Special Provisions for Structural Repair of Concrete.

LEGEND

- Concrete Removal
- Structural Repair of Concrete

DESIGNED	EML
CHECKED	NJM
DRAWN	EML
CHECKED	NJM

HORNER & SHIFRIN, INC.
ENGINEERS ■ ARCHITECTS ■ PLANNERS

**ABUTMENT REPAIR AND
CONCRETE REMOVAL DETAILS**
F.A.P. ROUTE 817 - SECTION 8BR-2
WASHINGTON COUNTY
STATION 25+18.00
STRUCTURE NO. 095-0010

PLOT DATE = 6/29/2006
 FILE NAME = c:\p0\jcts\wash\wash\817\817.dgn
 USER NAME = gmcj

ORIGINAL SURVEYED
 SUBMIT PLOTTED
 NO. DATE

FINAL SURVEYED
 SUBMIT PLOTTED
 NOTE BOOK TEMPLATE
 NO. DATE

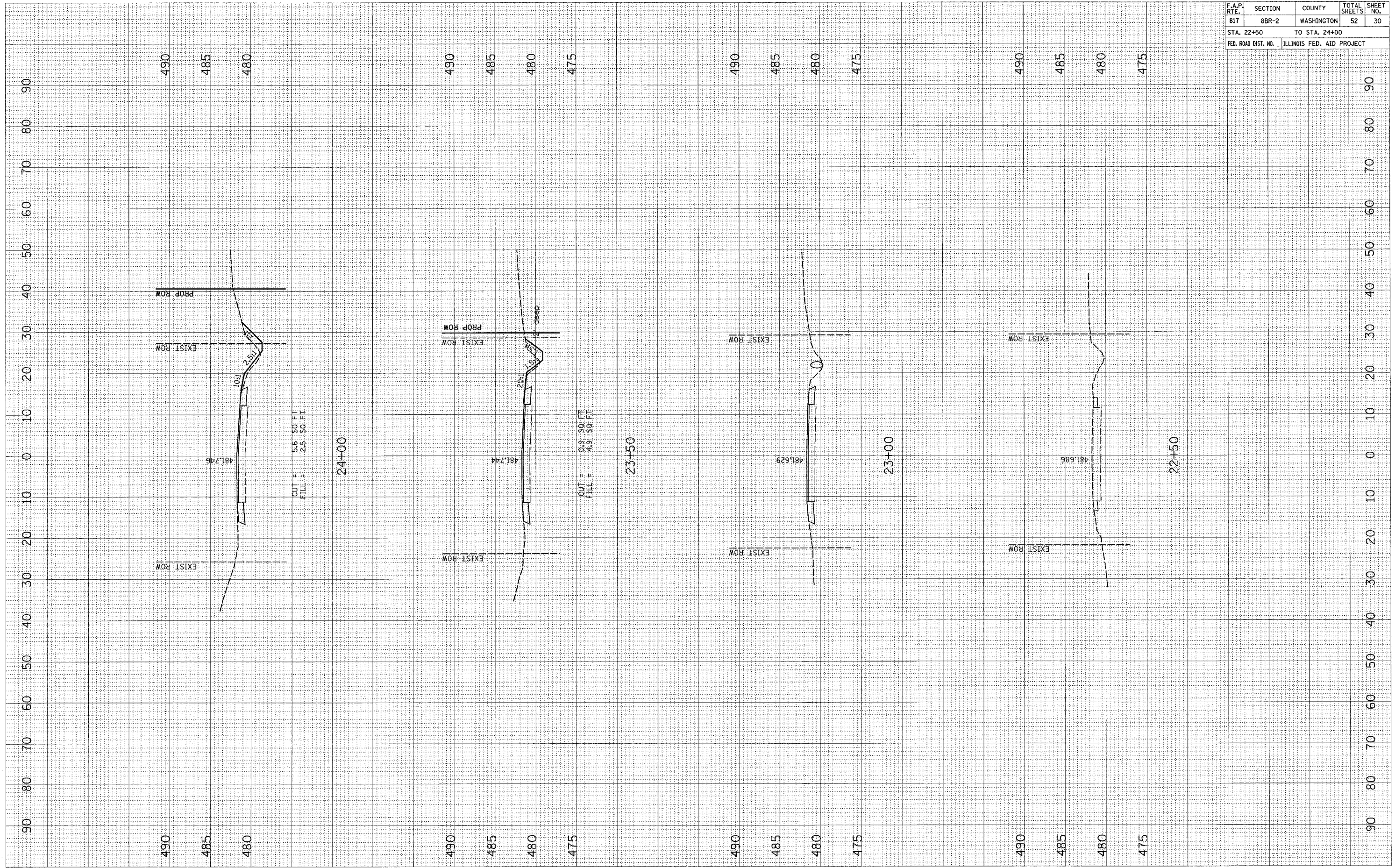

CONTRACT NO. 76946				
F.A.P. RTE.	SECTION	COUNTY	TOTAL SHEETS	SHEET NO.
817	8BR-2	WASHINGTON	52	30
STA. 22+50		TO STA. 24+00		
FED. ROAD DIST. NO. ILLINOIS FED. AID PROJECT				

PLOT DATE = 6/29/2006
 FILE NAME = c:\projects\va\89195\plan\wash\89195\89195.dwg
 PLOT SCALE = 10.0000' / 1" = 1000
 USER NAME = gneraj

ORIGINAL SURVEY
 SURVEY PLOTTED
 TEMPLATE AREAS CHECKED

FINAL SURVEY
 SURVEY PLOTTED
 NOTE BOOK AREAS CHECKED

BY: _____ DATE: _____

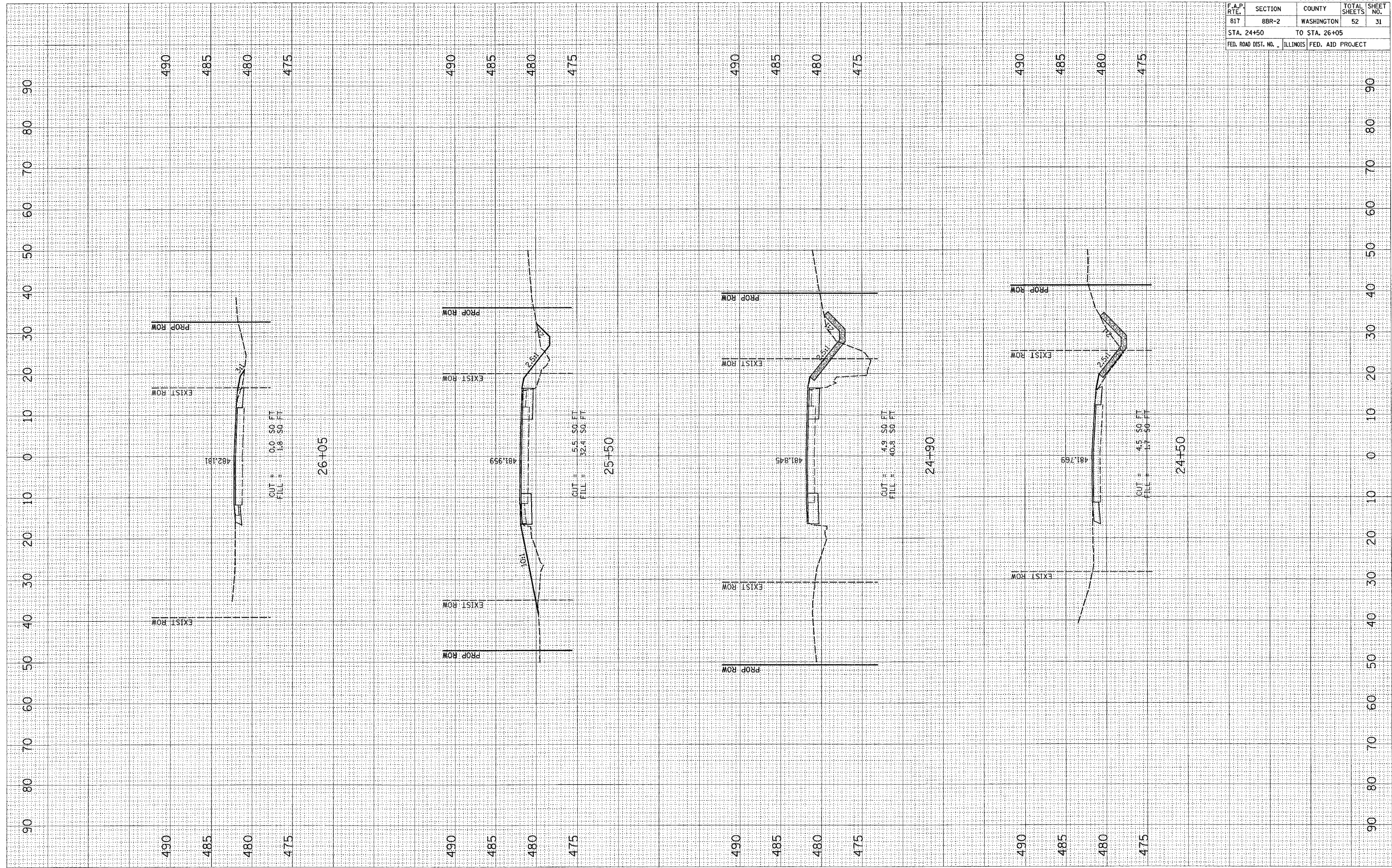

CONTRACT NO. 76946				
F.A.P. RTE.	SECTION	COUNTY	TOTAL SHEETS	SHEET NO.
817	BBR-2	WASHINGTON	52	31
STA. 24+50 TO STA. 26+05				
FED. ROAD DIST. NO. ILLINOIS FED. AID PROJECT				

PLOT DATE = 6/29/2006
 FILE NAME = c:\p\proj\15\15060905\plot\mainline\15060905.plt
 PLOT SCALE = 1/8" = 1' IN.
 USER NAME = omenkj

ORIGINAL SURVEY
 SURVEYED BY: _____
 PLOTTED BY: _____
 TEMPLATE: _____
 AREAS CHECKED: _____
 NO. _____

FINAL SURVEY
 SURVEYED BY: _____
 PLOTTED BY: _____
 TEMPLATE: _____
 AREAS CHECKED: _____
 NO. _____

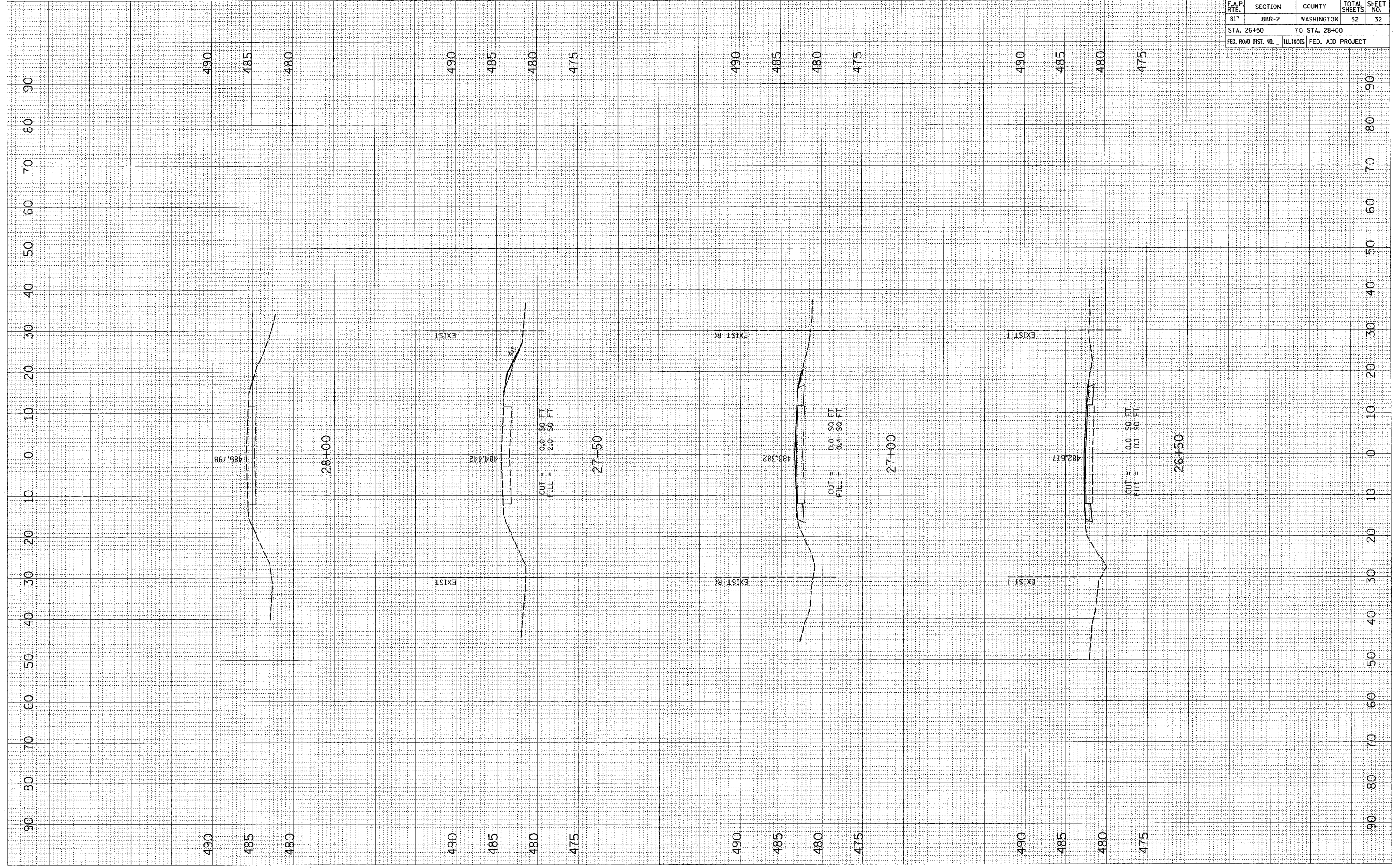

CONTRACT NO. 76946				
F.A.P. RTE.	SECTION	COUNTY	TOTAL SHEETS	SHEET NO.
817	8BR-2	WASHINGTON	52	32
STA. 26+50		TO STA. 28+00		
FED. ROAD DIST. NO.		ILLINOIS FED. AID PROJECT		

F.A.P. RTE.	SECTION	COUNTY	TOTAL SHEETS	SHEET NO.
817	8BR-2	WASHINGTON	52	33
STA. TO STA.		TO STA.		
FED. ROAD DIST. NO.		ILLINOIS	FED. AID PROJECT	

EARTHWORK SCHEDULE

LOCATION STATION TO STATION	EARTH EXCAVATION (WIDENING)	EARTH EXCAVATION ADJUSTED FOR SHRINKAGE (25%)	EMBANKMENT	EARTHWORK BALANCE WASTE (+) OR SHORTAGE (-)
	CU YD	CU YD	CU YD	CUYD
STA 33+50.0 TO STA 34+00.0			1.9	-1.9
STA 34+00.0 TO STA 34+50.0			8.9	-8.9
STA 34+50.0 TO STA 35+00.0	5.3	3.9	10.6	-6.6
STA 35+00.0 TO STA 35+50.0	5.3	3.9	6.1	-2.2
STA 35+50.0 TO STA 35+96.7	3.0	2.1	26.1	-24.1
SN 095-0010				
STA 36+28.7 TO STA 36+65.0	1.9	1.4	45.1	-43.7
STA 36+65.0 TO STA 37+00.0	3.9	2.9	38.7	-35.8
STA 37+00.0 TO STA 37+50.0	5.3	3.9	43.3	-39.4
STA 37+50.0 TO STA 38+00.0	5.3	3.9	34.5	-30.6
STA 38+00.0 TO STA 38+50.0			21.5	-21.5
STA 38+50.0 TO STA 39+00.0			13.2	-13.2
STA 39+00.0 TO STA 39+50.0			7.1	-7.1
SUBTOTAL	30	22	257	-235

GUARDRAIL SCHEDULE

LOCATION	GUARDRAIL REMOVAL	STEEL PLATE BEAM GUARDRAIL, TYPE A	REMOVE AND RE-ERECT STEEL PLATE BEAM GUARDRAIL, TYPE A	TRAFFIC BARRIER TERMINAL, TYPE 1, SPC (TANGENT)	REMOVE AND RE-ERECT TRAFFIC BARRIER TERMINAL, TYPE 1	TRAFFIC BARRIER TERMINAL, TYPE 1B	TRAFFIC BARRIER TERMINAL, TYPE 6A	GUARDRAIL MARKERS, TYPE A	TERMINAL MARKER - DIRECT APPLIED
	FOOT	FOOT	FOOT	EACH	EACH	EACH	EACH	EACH	EACH
EB IL 15								4	
WB IL 15								5	
NW QUADRANT	137.5 *	37.5				1	1		
NE QUADRANT	100	137.5	37.5		1		1		1
SW QUADRANT	100	75		1			1		1
SE QUADRANT	100	75		1			1		1
TOTAL	437.5	325 **	37.5	2 **	1	1	4	9	3

- * 50 FT TBT, TYPE 1 SPECIAL (TANGENT) (NW QUADRANT) PLACED FOR STAGE I INCLUDED IN GUARDRAIL REMOVAL.
- TBT, TYPE 1 SPECIAL (TANGENT) (NE QUADRANT) PLACED FOR STAGE I SHALL BE REMOVED AND RE-ERECTED TO ITS PERMANENT LOCATION.
- ** NOT A TOTAL QUANTITY. ADDITIONAL QUANTITY SHOWN IN STAGING SCHEDULE.

STAGING SCHEDULE

LOCATION	BITUMINOUS BASE COURSE WIDENING, 9"	TEMPORARY RUMBLE STRIPS	STEEL PLATE BEAM GUARDRAIL, TYPE A	TRAFFIC BARRIER TERMINAL, TYPE 1, SPC (TANGENT)	TEMPORARY CONCRETE BARRIER	RELOCATE TEMPORARY CONCRETE BARRIER	TEMPORARY PAVEMENT MARKING - LINE 6"	IMPACT ATTENUATOR, TEMPORARY (NON-REDIRECTIVE)	IMPACT ATTENUATOR, RELOCATE (NON-REDIRECTIVE)
	SQ YD	EACH	FOOT	EACH	FOOT	FOOT	FOOT	EACH	EACH
PRE-STAGE 1	247		37.5	2					
STAGE I		3			225		225	2	
STAGE II						225	225		2
TOTAL	247	3	37.5 **	2 **	225	225	450	2	2

** NOT A TOTAL QUANTITY. ADDITIONAL QUANTITY SHOWN IN GUARDRAIL SCHEDULE.

RESURFACING SCHEDULE

LOCATION STATION TO STATION	BITUMINOUS MATERIALS (PRIME COAT)	AGGREGATE (PRIME COAT)	BIUTMINOUS CONCRETE SURFACE COURSE, SUPERPAVE	BITUMINOUS SURFACE REMOVAL - 2"
	TON	TON	TON	SQ YD
STA 34+50.00 TO STA 35+00.00	0.05	0.27	14.9	133.3
STA 35+00.00 TO STA 35+50.00	0.05	0.27	14.9	133.3
STA 35+50.00 TO STA 35+76.79	0.02	0.19	8.2	71.5
STA 35+76.79 TO STA 35+96.71	0.02	0.19	8.2	73.1
STA 36+28.70 TO STA 36+48.63	0.02	0.19	8.2	73.2
STA 36+48.63 TO STA 36+65.00	0.01	0.14	5.1	43.7
STA 36+65.00 TO STA 37+00.00	0.03	0.21	10.7	93.3
STA 37+00.00 TO STA 37+50.00	0.05	0.27	14.9	133.3
STA 37+50.00 TO STA 38+00.00	0.05	0.27	14.9	133.3
TOTAL	0.3	2	100**	888

** BITUMINOUS CONCRETE SURFACE COURSE IS NOT A TOTAL QUANTITY SEE BRIDGE PLANS FOR ADDITIONAL QUANTITY

PAVEMENT MARKING SCHEDULE

LOCATION STATION TO STATION	PAVEMENT MARKING REMOVAL			THERMOPLASTIC PAVEMENT MARKING			TEMPORARY PAVEMENT MARKING LINE - 4"	SHORT-TERM PAVEMENT MARKING	WORK ZONE PAVEMENT MARKING REMOVAL	RAISED REFLECTIVE PAVEMENT MARKER REMOVAL	REPLACEMENT REFLECTOR	RAISED REFLECTIVE PAVEMENT MARKER	RAISED REFLECTIVE PAVEMENT MARKER (BRIDGE)
	DOUBLE SOLID CENTERLINE 4" YELLOW	EDGE LINE 4" WHITE		DOUBLE SOLID CENTERLINE 4" YELLOW	EDGE LINE 4" WHITE								
		LT	RT		LT	RT							
STA 33+20.00 TO STA 39+20.00	400	200	200	1200	600	600	2400	56	819	7	2	4	1
SUB-TOTAL	400	200	200	1200	600	600							
TOTAL	800			2400			2400	56	819	7	2	4	1

TEMPORARY RAMP SCHEDULE

LOCATION	WIDTH	LENGTH	TEMPORARY RAMP
	FOOT	FOOT	SQ YD
STA 34+50	24	6.75	18
STA 38+00	24	6.75	18
TOTAL			36

REVISIONS	
NAME	DATE

ILLINOIS DEPARTMENT OF TRANSPORTATION

SCHEDULE OF QUANTITIES

FAP ROUTE 817
SECTION 8BR-3
WASHINGTON COUNTY
SN 095-0011

ALL QUANTITIES ON THIS SHEET ARE NOT TOTAL PROJECT QUANTITIES. THE QUANTITIES ON THIS SHEET ARE THE TOTAL FOR SN 095-0011.

F.A.P. RTE.	SECTION	COUNTY	TOTAL SHEETS	SHEET NO.
817	8BR-3	WASHINGTON	52	34
STA. 33+15		TO STA. 39+25		
FED. ROAD DIST. NO.	ILLINOIS	FED. AID PROJECT		

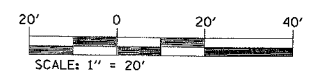
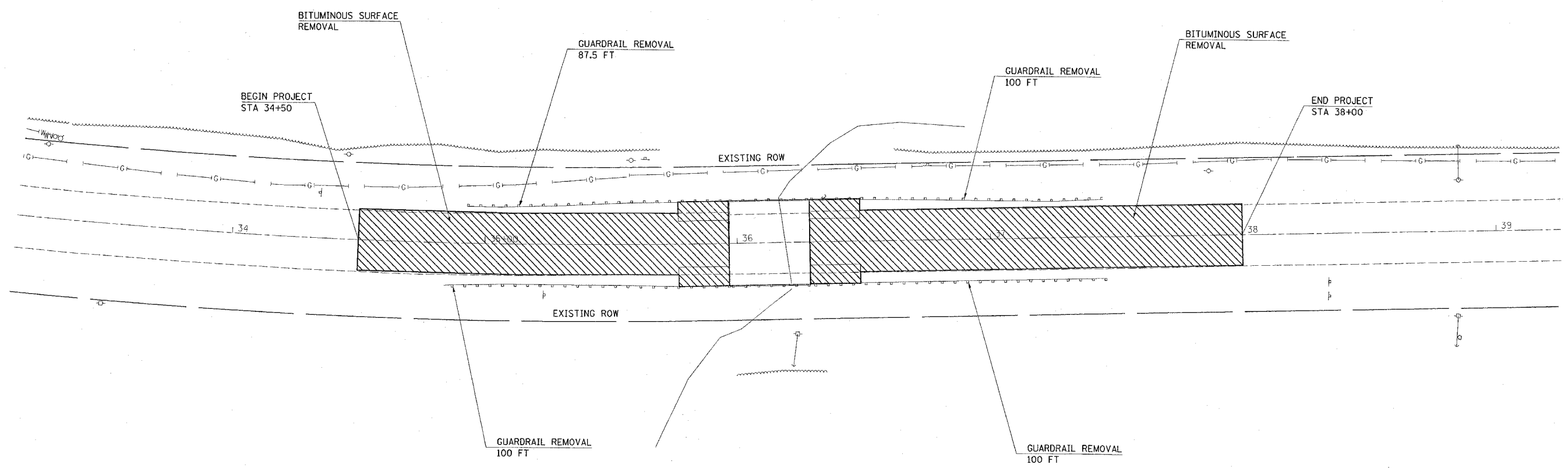

REVISIONS	
NAME	DATE

ILLINOIS DEPARTMENT OF TRANSPORTATION
REMOVAL PLAN
 FAP ROUTE 817
 SECTION 8BR-3
 WASHINGTON COUNTY
 SN 095-0011

PLOT DATE *
 FILE NAME *
 PLOT SCALE *
 REFERENCE *

F.A.P. RTE.	SECTION	COUNTY	TOTAL SHEETS	SHEET NO.
817	8BR-3	WASHINGTON	52	35
STA. 33+15		TO STA. 39+25		
FED. ROAD DIST. NO.		ILLINOIS FED. AID PROJECT		



EXIST. CURVE C2
 PI STA. = 33+62.47
 $\Delta = 11^\circ 32' 20''$ (LT)
 $D = 2^\circ 33' 28''$
 $R = 2,240.00'$
 $T = 226.32'$
 $L = 451.11'$
 $E = 11.40'$
 $e =$
 $T.R. =$
 $S.E. RUN =$
 $P.C. STA. = 31+36.15$
 $P.T. STA. = 35+87.26$

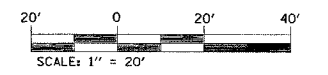
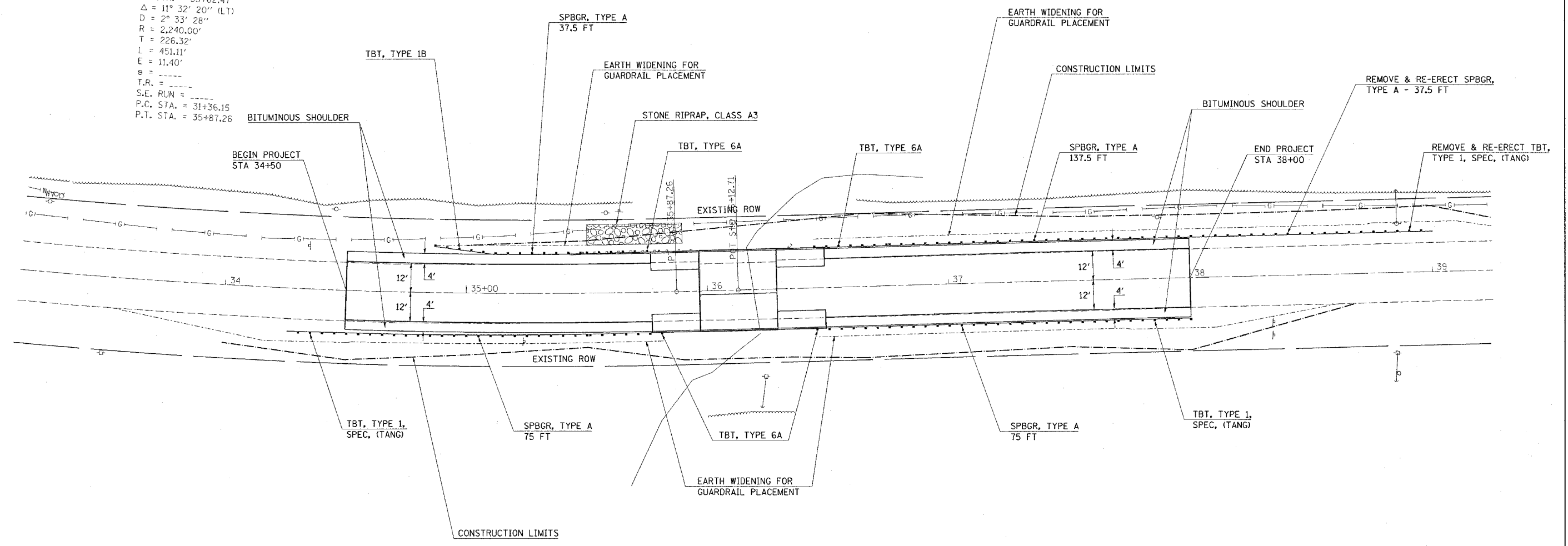

REVISIONS	
NAME	DATE

ILLINOIS DEPARTMENT OF TRANSPORTATION
PLAN VIEW
 FAP ROUTE 817
 SECTION 8BR-3
 WASHINGTON COUNTY
 SN 095-0011

PLOT DATE = 7/18/2005
 FILE NAME = c:\p\projects\817\plan\p1n081905.dgn
 PLOT SCALE = 20.0000 / 1 IN.
 REFERENCE = NONE

F.A.P. RTE.	SECTION	COUNTY	TOTAL SHEETS	SHEET NO.
817	8BR-3	WASHINGTON	52	36
STA. 33+15		TO STA. 39+25		
FED. ROAD DIST. NO.	ILLINOIS FED. AID PROJECT			



EXIST. CURVE C2
 PI STA. = 33+62.47
 Δ = 11° 32' 20" (LT)
 D = 2° 33' 28"
 R = 2,240.00'
 T = 226.32'
 L = 451.11'
 E = 11.40'
 e = -----
 T.R. = -----
 S.E. RUN = -----
 P.C. STA. = 31+36.15
 P.T. STA. = 35+87.26

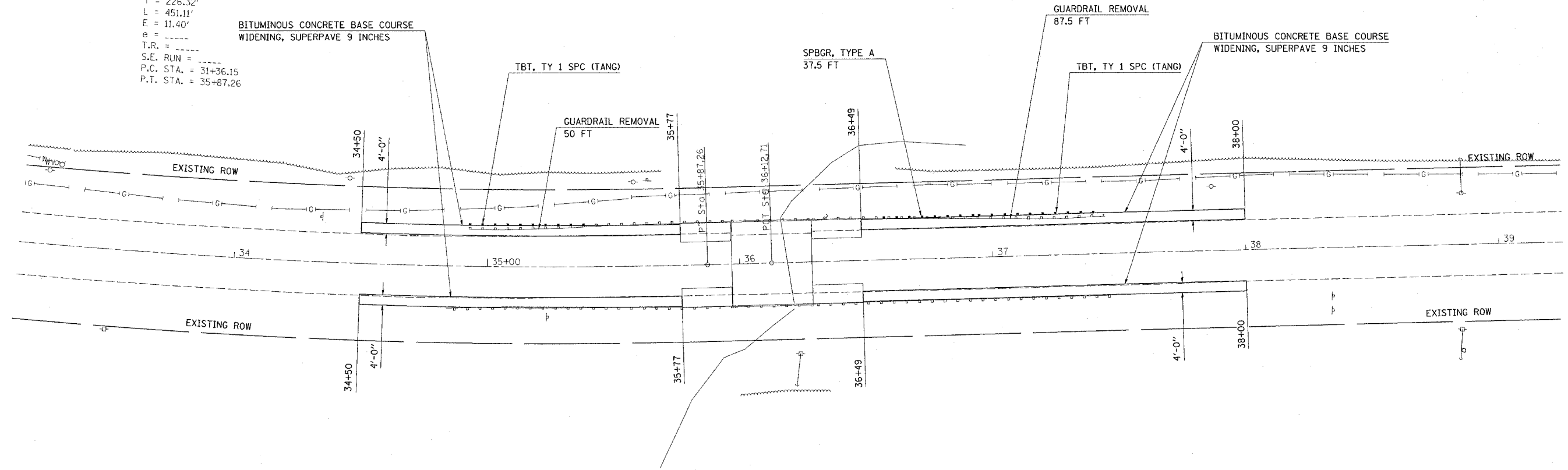

PRE-STAGE I DESCRIPTION OF WORK:

REMOVE EXISTING GUARDRAIL THAT WILL CONFLICT WITH PROPOSED WIDENING. (50 FT IN NW QUADRANT AND 87.5 FT IN NE QUADRANT) THIS INCLUDES EXISTING END SECTIONS.

PLACE TBT, TYPE 1 SPECIAL (TANGENT) IN NW QUADRANT.

PLACE 37.5 FT OF TEMPORARY STEEL PLATE BEAM GUARDRAIL AND TBT, TYPE 1 SPECIAL (TANGENT) IN NE QUADRANT.

PLACE "BITUMINOUS CONCRETE BASE COURSE WIDENING, SUPERPAVE 9 INCHES" TO ALLOW FOR TRAFFIC IN STAGE I AND II.

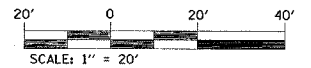

REVISIONS	
NAME	DATE

ILLINOIS DEPARTMENT OF TRANSPORTATION
STAGE CONSTRUCTION
PRE-STAGE I
 FAP ROUTE 817
 SECTION 8BR-3
 WASHINGTON COUNTY
 SN 095-0011

F.A.P. RTE.	SECTION	COUNTY	TOTAL SHEETS	SHEET NO.
817	8BR-3	WASHINGTON	52	37
STA. 33+15		TO STA. 39+25		
FED. ROAD DIST. NO.	ILLINOIS	FED. AID PROJECT		



LEGEND

- IMPACT ATTENUATOR
- TEMPORARY CONCRETE BARRIER
- BARRELS OR BARRICADES WITH STEADY BURNING LIGHT
- TEMPORARY BRIDGE TRAFFIC SIGNALS
- TYPE III BARRICADE

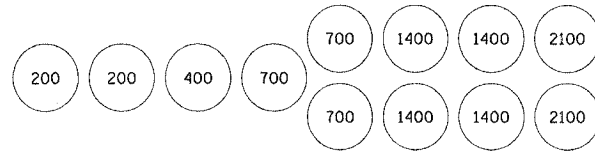

SAND BARREL LAYOUT
(IF OPTION USED)

EXIST. CURVE C2
 PI STA. = 33+62.47
 $\Delta = 11^\circ 32' 20''$ (LT)
 $D = 2^\circ 33' 28''$
 $R = 2,240.00'$
 $T = 226.32'$
 $L = 451.11'$
 $E = 11.40'$
 $e =$
 $T.R. =$
 $S.E. RUN =$
 $P.C. STA. = 31+36.15$
 $P.T. STA. = 35+87.26$

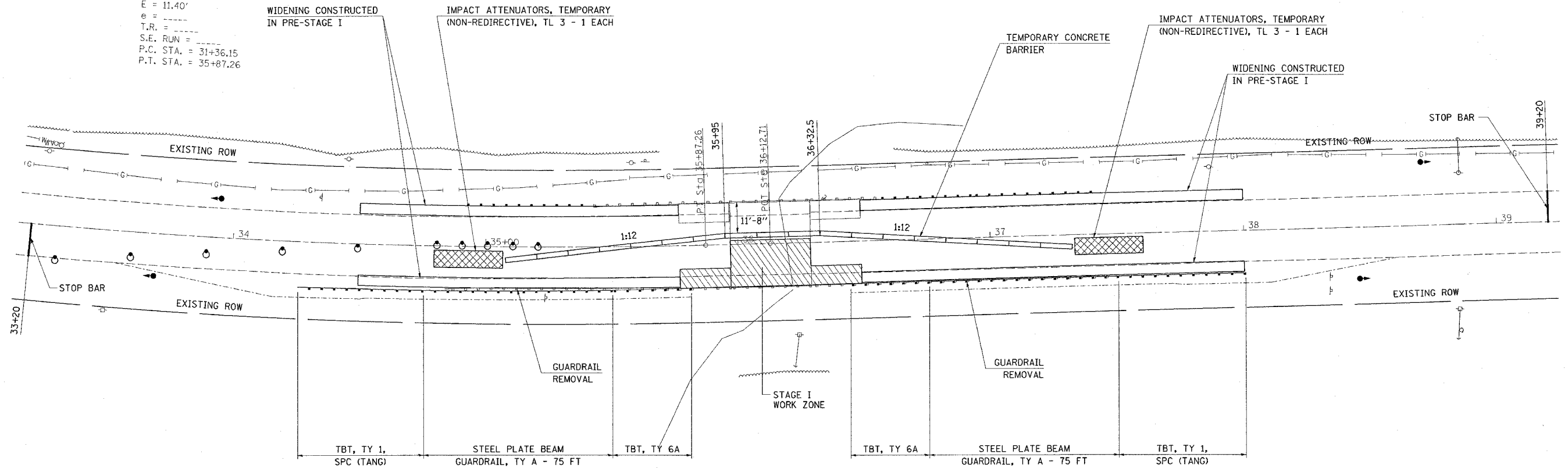

SEQUENCE OF CONSTRUCTION:

THE CONTRACTOR SHALL GIVE ILLINOIS DEPARTMENT OF TRANSPORTATION, BUREAU OF OPERATIONS TWO WEEKS NOTICE FOR PREPARATION OF THE STATE FURNISHED TRAFFIC CONTROLLER. THE CONTRACTOR SHALL PICK UP THE TRAFFIC CONTROLLER AT THE T.M. BUILDING.

PLACE STOP BARS AS SHOWN ON PLANS.

PLACE TEMPORARY RUMBLE STRIPS (3 EACH) WEST OF STRUCTURE FOR EASTBOUND TRAFFIC.

REMOVE CENTERLINE AND CONFLICTING SOLID EDGE PAVEMENT MARKINGS BETWEEN STOP BARS.

PLACE 225 FT TEMPORARY CONCRETE BARRIER AND 2 EACH IMPACT ATTENUATORS, TEMPORARY.

SEE STANDARD 701321 FOR DETAILS NOT SHOWN ON PLANS.

PERFORM ALL NECESSARY BRIDGE WORK IN STAGE I WORK ZONE.

REMOVE EXISTING GUARDRAIL ON SOUTH SIDE AND REPLACE WITH PROPOSED TBT, TYPE 6A, STEEL PLATE BEAM GUARDRAIL, TYPE A AND TBT, TYPE 1 (SPECIAL) TANGENT IN SW AND SE QUADRANTS.



REVISIONS	
NAME	DATE





ILLINOIS DEPARTMENT OF TRANSPORTATION
STAGE CONSTRUCTION
STAGE I
 FAP ROUTE 817
 SECTION 8BR-3
 WASHINGTON COUNTY
 SN 095-0011

PLOT DATE = 7/19/2006
 FILE NAME = c:\p09\mcs\w888888\plan\stage01.dgn
 PLOT SCALE = 20.0000 / IN.
 USER NAME = owerby

F.A.P. RTE.	SECTION	COUNTY	TOTAL SHEETS	SHEET NO.
817	8BR-3	WASHINGTON	52	38
STA. 33+15		TO STA. 39+25		
FED. ROAD DIST. NO.		ILLINOIS FED. AID PROJECT		



LEGEND

-  IMPACT ATTENUATOR
-  TEMPORARY CONCRETE BARRIER
-  BARRELS OR BARRICADES WITH STEADY BURNING LIGHT
-  TEMPORARY BRIDGE TRAFFIC SIGNALS
-  TYPE III BARRICADE

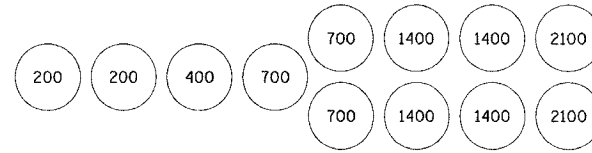

SAND BARREL LAYOUT
(IF OPTION USED)

EXIST. CURVE C2
 PI STA. = 33+62.47
 $\Delta = 11^\circ 32' 20''$ (LT)
 $D = 2^\circ 33' 28''$
 $R = 2,240.00'$
 $T = 226.32'$
 $L = 451.11'$
 $E = 11.40'$
 $e =$
 $T.R. =$
 $S.E. RUN =$
 $P.C. STA. = 31+36.15$
 $P.T. STA. = 35+87.26$

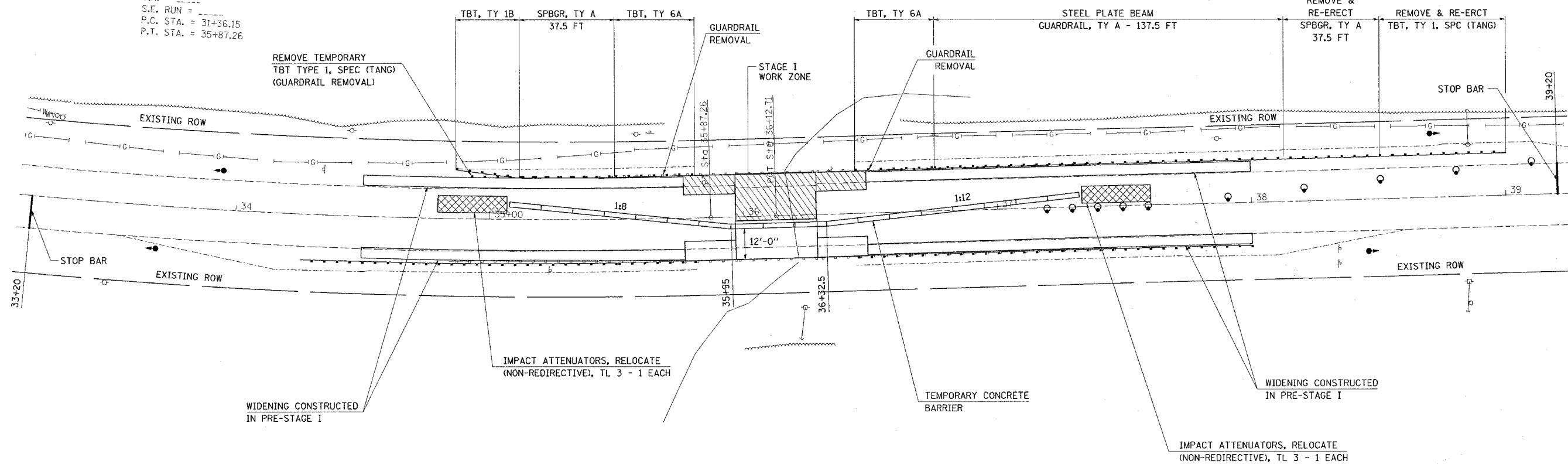

SEQUENCE OF CONSTRUCTION:

- RELOCATE 225 FT TEMPORARY CONCRETE BARRIER AND 2 EACH IMPACT ATTENUATORS.
- SEE STANDARD 701321 FOR DETAILS NOT SHOWN ON PLANS.
- PERFORM ALL NECESSARY BRIDGE WORK IN STAGE II WORK ZONE.
- REMOVE TBT, TYPE 1 SPECIAL (TANGENT) ON THE NW SIDE THAT WAS PLACED IN THE PRE-STAGE AND ALL OTHER EXISTING GUARDRAIL ON NORTH SIDE.
- REMOVE AND RE-ERECT STEEL PLATE BEAM GUARDRAIL, TYPE A (37.5 FT) AND TBT, TYPE 1 SPECIAL (TANGENT) IN THE NE QUADRANT THAT WAS PLACED IN THE PRE-STAGE.
- PLACE PROPOSED TBT, TYPE 6A, STEEL PLATE BEAM GUARDRAIL, TYPE A AND TBT, TYPE 1B ON THE NORTH SIDE



REVISIONS	
NAME	DATE

ILLINOIS DEPARTMENT OF TRANSPORTATION
STAGE CONSTRUCTION
STAGE II
 FAP ROUTE 817
 SECTION 8BR-3
 WASHINGTON COUNTY
 SN 095-0011

PLOT DATE = 7/19/2006
 FILE NAME = c:\projects\va068985\plan\va068985.dgn
 USER NAME = sbruce

F.A.P. RTE.	SECTION	COUNTY	TOTAL SHEETS	SHEET NO.
817	8BR-3	WASHINGTON	52	39
STA. 33+15		TO STA. 39+25		
FED. ROAD DIST. NO.	ILLINOIS	FED. AID PROJECT		

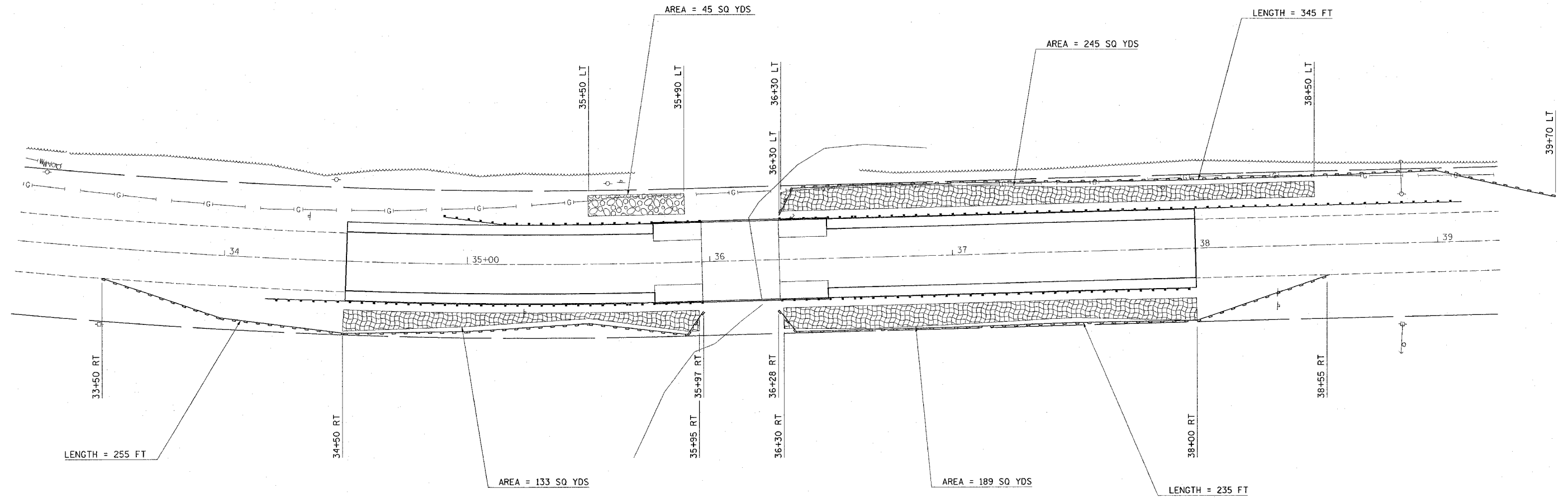

LEGEND

- EROSION CONTROL BLANKET
- PERIMETER EROSION BARRIER- SILT FILTER FENCE OR OTHER AS APPROVED BY THE ENGINEER
- STONE RIPRAP, CLASS A3



REVISIONS	
NAME	DATE

ILLINOIS DEPARTMENT OF TRANSPORTATION
EROSION CONTROL SHEET
 FAP ROUTE 817
 SECTION 8BR-3
 WASHINGTON COUNTY
 SN 095-0011

PLOT DATE = #DATE#
 FILE NAME = #FILE#
 PLOT SCALE = #SCALE#
 REFERENCE = #REF#

F.A.P. RTE.	SECTION	COUNTY	TOTAL SHEETS	SHEET NO.
817	8BR-3	WASHINGTON	52	40
STA. 33+15		TO STA. 39+25		
FED. ROAD DIST. NO.	ILLINOIS	FED. AID PROJECT		

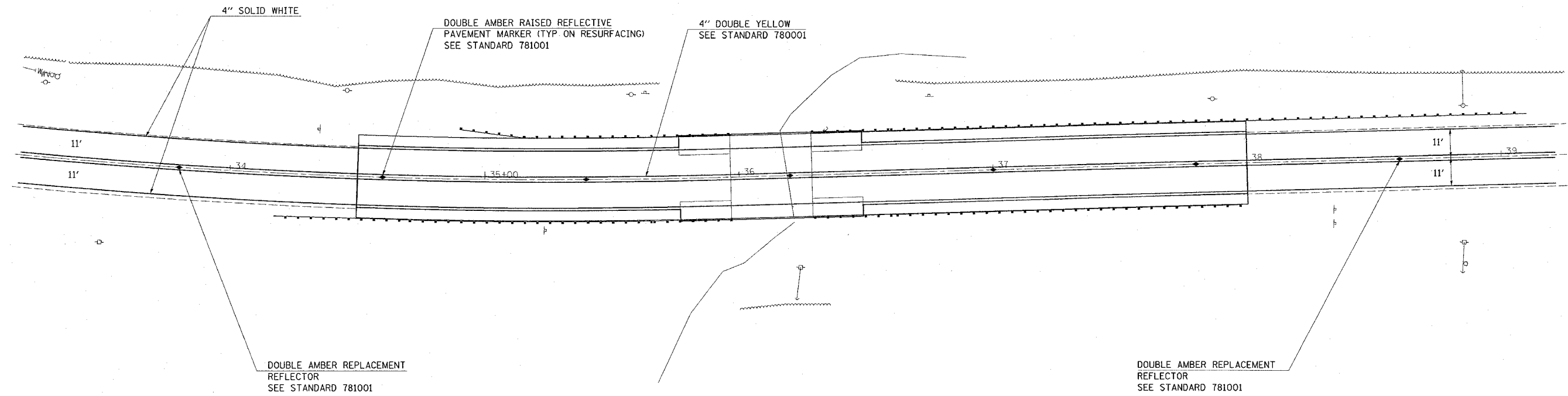

REVISIONS	
NAME	DATE

ILLINOIS DEPARTMENT OF TRANSPORTATION
PAVEMENT MARKING SHEET
 FAP ROUTE 817
 SECTION 8BR-3
 WASHINGTON COUNTY
 SN 095-0011

* DATE *
 * NAME *
 * SCALE *
 * REF *

Bench Mark: RR Spike in South Side of Power Pole on North Side of Route 15, approximately 18' West & 18' North of Northwest Corner of S.N. 095-0011 Bridge Deck, Elev. 489.84.

Existing Structure: S.N. 095-0011 was built in 1921 as S.B.I. Rte. 15 Sec. 8B at Sta. 36+25.00. In 1971 the superstructure was replaced, and the substructure widened. The existing single span structure consists of PPC deck beams on spread footing supported closed abutments. The bk. to bk. abts dimension measures 32'-0" while the O.-O. width measures 33'-0". The existing superstructure shall be replaced with PPC deck beams, and the substructure will be repaired with Structural Repair of concrete. Staging shall be used during construction.

No Salvage.

STATE OF ILLINOIS
DEPARTMENT OF TRANSPORTATION

ROUTE NO.	SECTION	COUNTY	SHEETS	SHEET NO.	SHEET NO. 1
F.A.P. 817	8BR-2, 8BR-3	WASHINGTON	52	41	9 SHEETS
FED. ROAD DIST. NO. 7	ILLINOIS	FED. AID PROJECT			

Contract #76946

INDEX OF SHEETS

1. General Plan
2. Stage Construction Details
3. Temporary Concrete Barrier for Stage Construction
4. Type SM Steel Bridge Rail Side Mounted
5. Bridge Approach Pavement (Special)
- 6-7. Superstructure Details
8. Abutments
9. Abutment Repair Details

GENERAL NOTES

Attach new Name Plate to the backside of 8" rail element. Existing Name Plate is to be removed, cleaned and relocated adjacent to new Name Plate. Cost included in the cost of Name Plates.

Repair of the abutments shall be completed prior to placement of the new deck beams.

The minimum thickness of Bituminous overlay shall be 2" and varies as required to adjust for the new profile grade and beam camber.

Plan dimensions and details relative to existing structure have been taken from existing plans and are subject to nominal construction variations. It shall be the Contractor's responsibility to verify such dimensions and details in the field and make necessary approved adjustments prior to construction or ordering of materials. Such variations shall not be cause for additional compensation for a change in the scope of the work, however, the Contractor will be paid for the quantity actually furnished at the unit price for the work.

The top surface of the beams shall be finished according to Article 504.06 of the Standard Specifications except that the surface shall not be roughened by brooming. The finished surface shall be free of depressions or high spots with sharp corners, and the top edge of keys shall be rounded or chamfered a minimum of 1/4".

All Construction joints shall be bonded. The cut strands at each beam end shall be given two coats of zinc dust spray or paint meeting the requirements of ASTM A 780. The zinc dust spray or paint shall be applied before corrosion appears and allowed to dry according to the manufacturer's specifications prior to another coat of zinc. A concrete sealer meeting the requirements of Section 587 of the Standard Specifications shall be applied to the exterior face and 9" in on the underside of the fascia beams. The sealer shall be applied after visible crack growth has subsided. This work shall be performed by the producer and included with the cost of the beam.

The contractor is advised that the existing Precast Prestressed Concrete Deck Beams are in a deteriorated condition with reduced load carrying capacity. It is the contractor's responsibility to account for the condition of the beams when developing construction procedures for removal and replacement of the superstructure.

TOTAL BILL OF MATERIAL

ITEM	UNIT	SUPER	SUB	TOTAL
Bridge Approach Pavement (Special)	Sq. Yd.		66	66
Removal of Existing Superstructures	Each	1		1
Concrete Removal	Cu. Yd.		9.2	9.2
Precast Prestressed Concrete Deck Beams (17" Depth)	Sq. Ft.	1051		1051
Steel Bridge Rail, Type SM	Foot	126		126
Name Plates	Each	1		1
Expansion Bolts 3/4 Inch	Each		112	112
Waterproofing Membrane System	Sq. Yd.	117		117
Portland Cement Mortar Fairing Course	Foot	318		318
Removal of Existing Precast Concrete Units	Sq. Ft.	299		299
Structural Repair of Concrete (Depth Equal to or less than 5")	Sq. Ft.		6.5	6.5
Bituminous Concrete Surface Course Superpave, Mix "C", N70	Ton	16		16

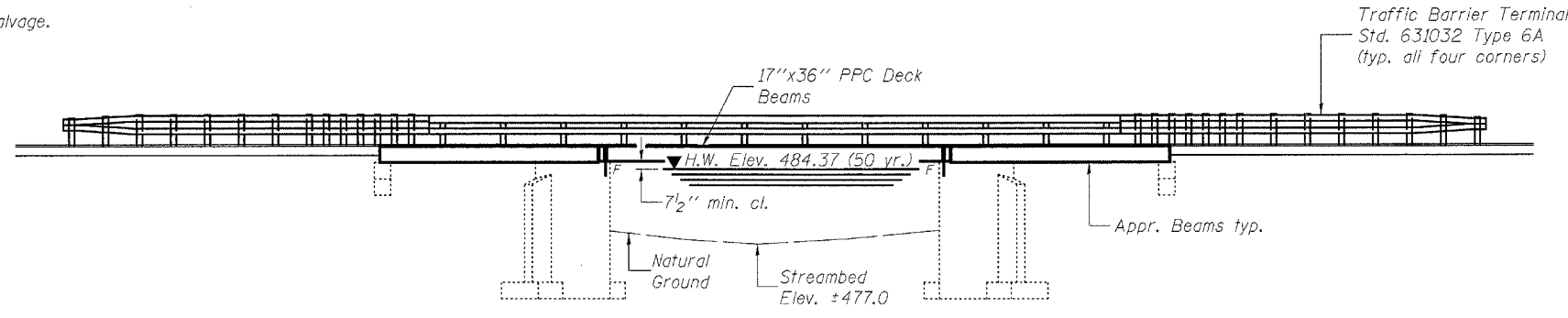

ELEVATION

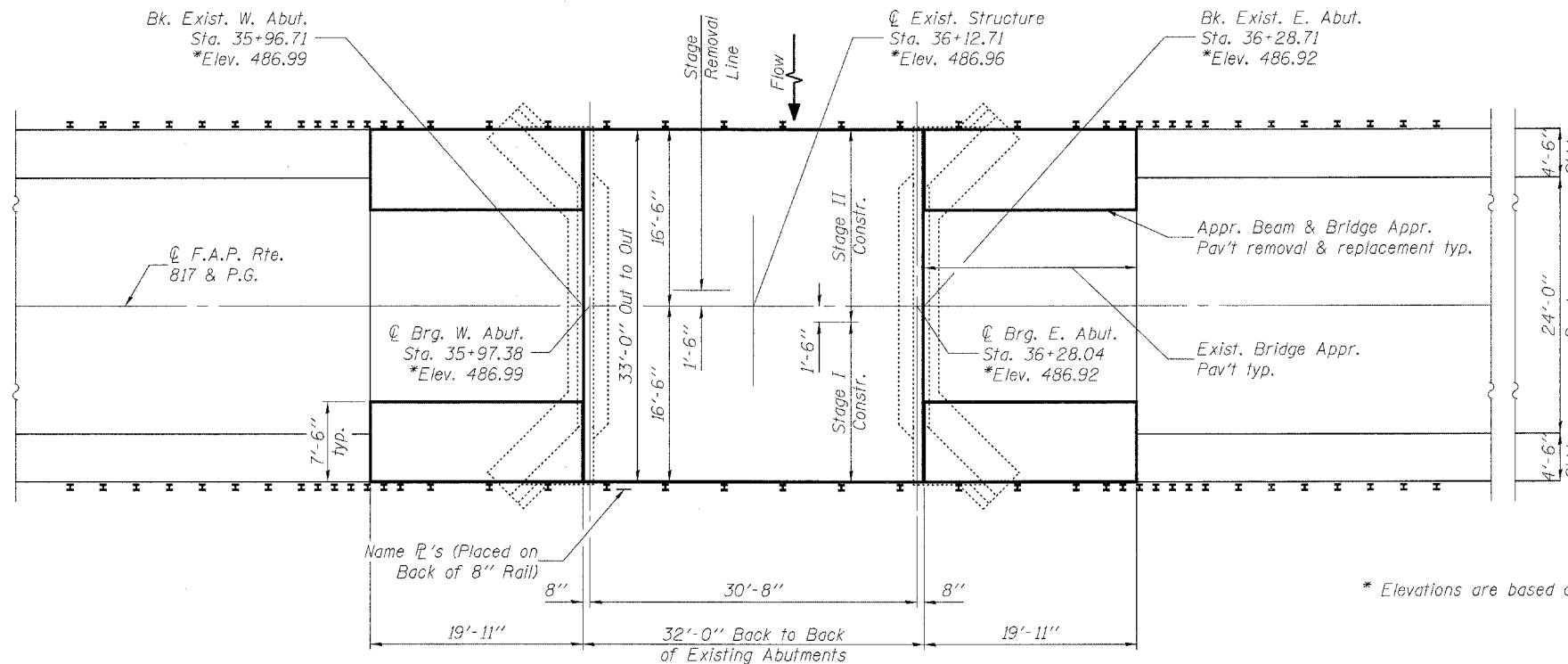

PLAN

LOADING HS20-44 (New Construction)

No Allowance for future wearing surface.

DESIGN SPECIFICATIONS (New Construction)

2002 AASHTO

DESIGN STRESSES

FIELD UNITS

$f'_c = 3,500$ psi
 $f_y = 60,000$ psi (reinforcement)

PRECAST PRESTRESSED UNITS

$f'_c = 5,000$ psi
 $f'_{ci} = 4,000$ psi
 $f'_s = 270,000$ psi (1/2" ϕ low lax. strands)
 $f_{si} = 201,960$ psi (1/2" ϕ low lax. strands)

DESIGNED	EML
CHECKED	NJM
DRAWN	EML
CHECKED	NJM

HORNER & SHIFRIN, INC.
ENGINEERS ■ ARCHITECTS ■ PLANNERS

STATION 36+12.71
RE-BUILT 200 BY
STATE OF ILLINOIS
FAP RT 817 - SEC 8BR-3
LOADING HS20
STR. NO. 095-0011
NAME PLATE
See Std. 515001



Eric Lagemann 6/21/06
Expires 11/30/2006

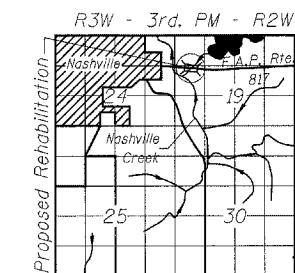

LOCATION SKETCH

GENERAL PLAN
ILLINOIS ROUTE 15 OVER
NASHVILLE CREEK
F.A.P. ROUTE 817 - SECTION 8BR-3
WASHINGTON COUNTY
STATION 36+12.71
STRUCTURE NO. 095-0011

STATE OF ILLINOIS
DEPARTMENT OF TRANSPORTATION

ROUTE NO.	SECTION	COUNTY	TOTAL SHEETS	SHEET NO.
F.A.P. 817	8BR-2, 8BR-3	WASHINGTON	52	42
FED. ROAD DIST. NO. 7	ILLINOIS	FED. AID PROJECT		

SHEET NO. 2

9 SHEETS

Contract #76946

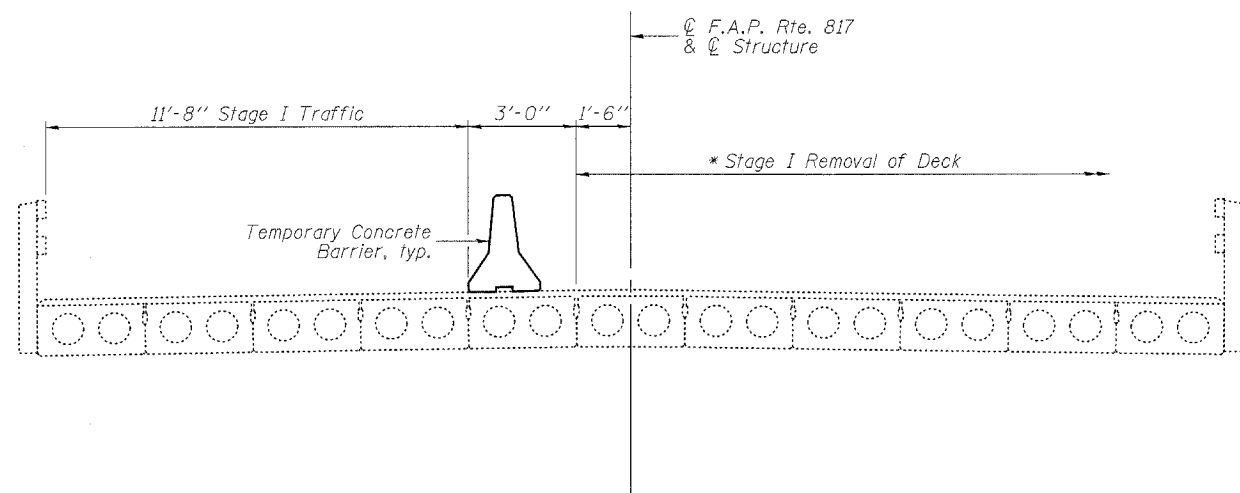

STAGE I REMOVAL

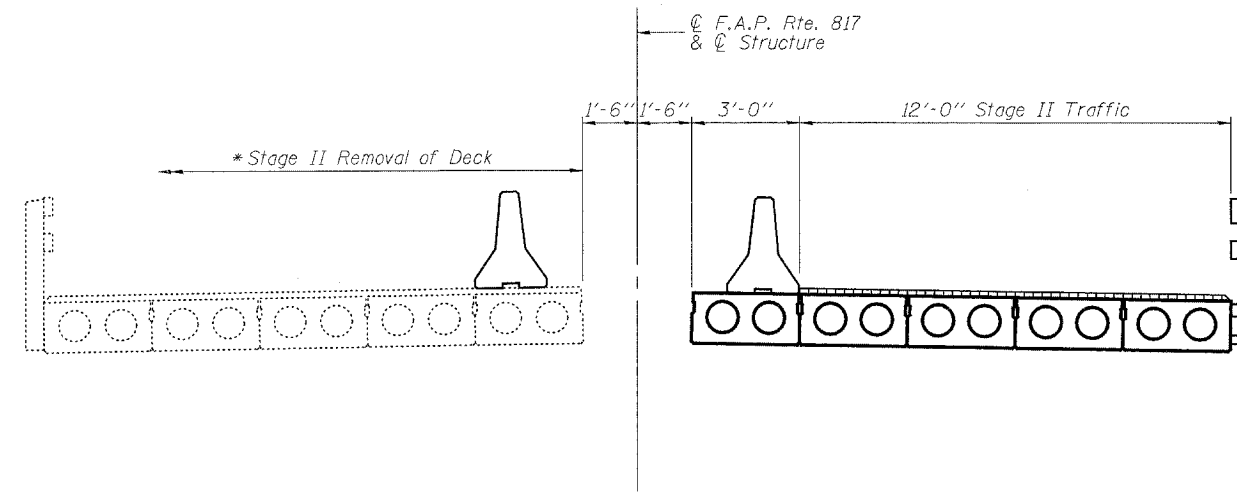

STAGE II REMOVAL

* The Contractor is required to brace the abutments at the beam seats longitudinally prior to the deck beam removal process. The braces shall stay in place until all new deck beams are doweled into position. This is to prevent the development of excessive stresses in the abutments during construction. Bracing details and computations are to be submitted to the Engineer for approval. The cost is included in Removal of Existing Superstructures.

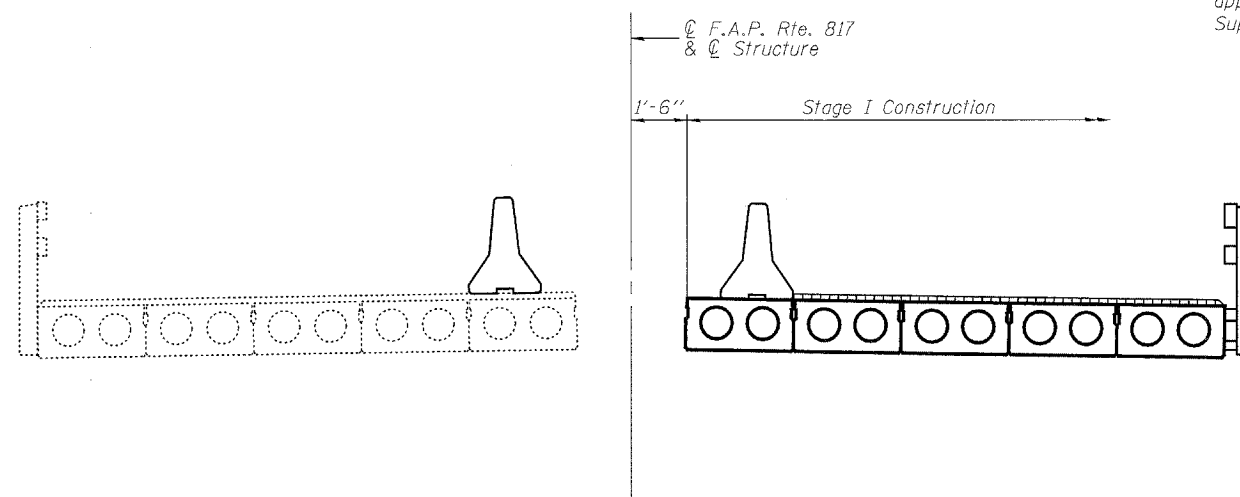

STAGE I CONSTRUCTION

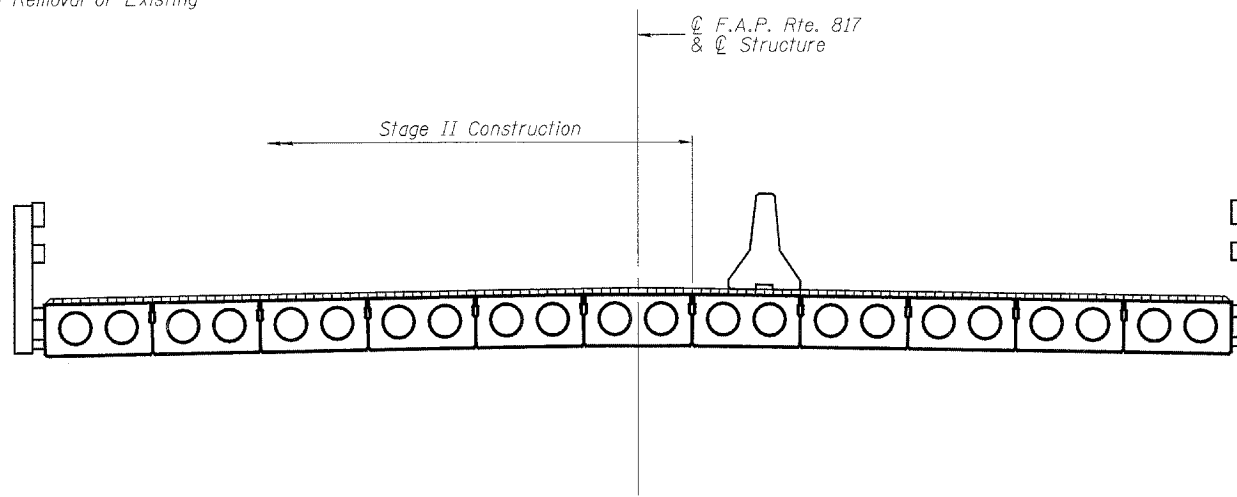

STAGE II CONSTRUCTION

Notes:
All sections are looking East.
For quantity of Temporary Concrete Barrier, see roadway plans.
For details of Temporary Concrete Barrier, see sheet 3 of 9.
For requirements for lapping waterproofing membrane, see notes on sheet 3 of 9.

DESIGNED	EML
CHECKED	NJM
DRAWN	EML
CHECKED	NJM

HORNER & SHIFRIN, INC.
ENGINEERS ■ ARCHITECTS ■ PLANNERS

STAGE CONSTRUCTION DETAILS
F.A.P. ROUTE 817 - SECTION 8BR-3
WASHINGTON COUNTY
STATION 36+12.71
STRUCTURE NO. 095-0011

STATE OF ILLINOIS
DEPARTMENT OF TRANSPORTATION

ROUTE NO.	SECTION	COUNTY	TOTAL SHEETS	SHEET NO.
F.A.P. 817	8BR-2, 8BR-3	WASHINGTON	52	43
FED. ROAD DIST. NO. 7	ILLINOIS	FED. AID PROJECT-		

SHEET NO. 3

9 SHEETS

Contract #76946

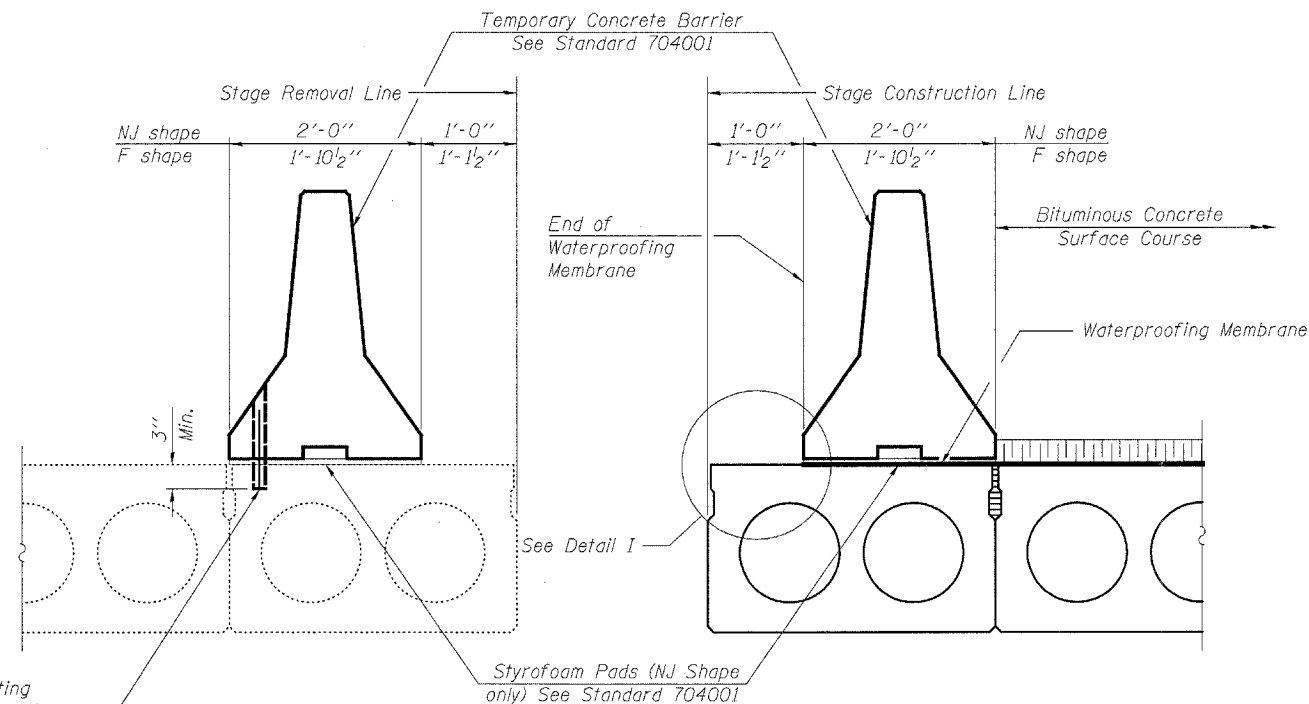

Drill 1/4" ϕ Holes in existing beam for 1" ϕ x 10" dowel bars. Traffic side only. Cost included with Temporary Concrete Barrier.

EXISTING PPC DECK BEAMS

NEW PPC DECK BEAMS

SECTIONS THRU PPC DECK BEAMS

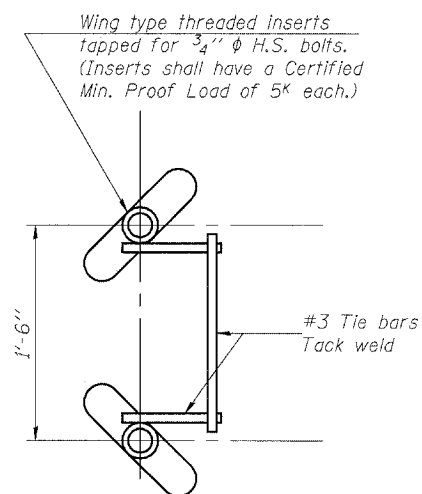

INSERT DETAIL

2 - Wing type threaded inserts for 3/4" ϕ H.S. bolts with flat hardened washer. Grout holes after removal.

Wood Blocks

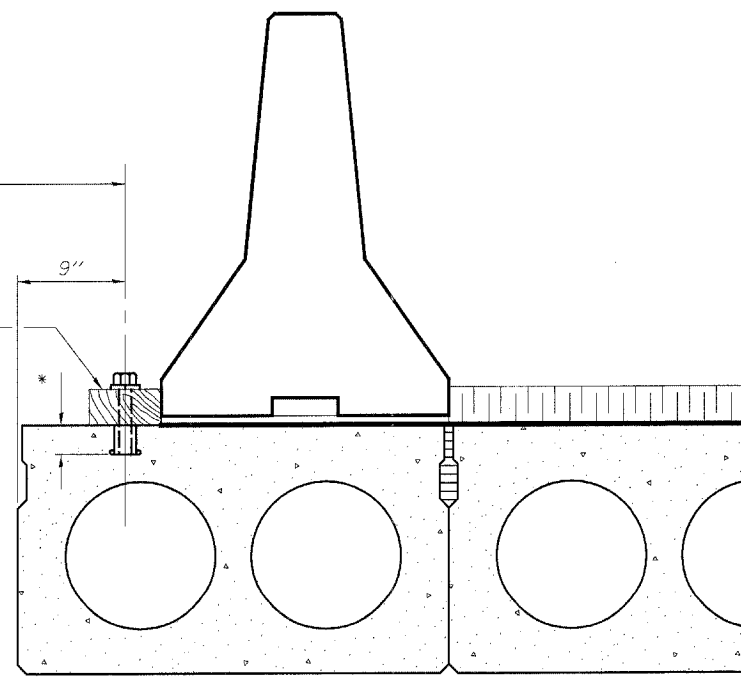

DETAIL I

The Temporary Concrete Barrier and wood blocks shall not be removed until Stage II Construction PPC Deck Beams have been placed and shear keys grouted.

NOTES

The 3/4" ϕ high strength bolts used to connect the wood blocks shall be tightened to a snug fit without crushing the wood block. The wing type threaded insert assembly shall be spaced 6'-0" longitudinally.

The Waterproofing Membrane shall extend under the Temporary Concrete Barrier without the asphalt sand seal protection layer. Once the Temporary Concrete Barrier has been removed, and the penetrating primer, coal tar emulsion, coal tar emulsion and fiberglass fabric, and coal tar emulsion slurry layers of the Waterproofing Membrane is lapped 6", the asphalt sand seal protection layer shall be applied according to Article 581 of the Standard Specifications.

The cost for H.S. bolts, flat headed washers, and wood block is included with Temporary Concrete Barrier.

The cost for wing type threaded inserts is included with Precast Prestressed Concrete Deck Beams (17" Depth).

DESIGNED	EML
CHECKED	NJM
DRAWN	EML
CHECKED	NJM

HORNER & SHIFRIN, INC.
ENGINEERS ■ ARCHITECTS ■ PLANNERS

TEMPORARY CONCRETE BARRIER
FOR STAGE CONSTRUCTION
F.A.P. ROUTE 817 - SECTION 8BR-3
WASHINGTON COUNTY
STATION 36+12.71
STRUCTURE NO. 095-0011

STATE OF ILLINOIS
DEPARTMENT OF TRANSPORTATION

ROUTE NO.	SECTION	COUNTY	TOTAL SHEETS	SHEET NO.	SHEET NO.
F.A.P. 817	8BR-2, 8BR-3	WASHINGTON	52	44	9
FED. AID DIST. NO. 7	ILLINOIS	FED. AID PROJECT-			

Contract #76946

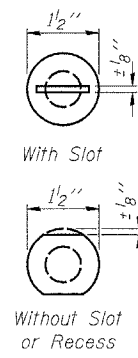
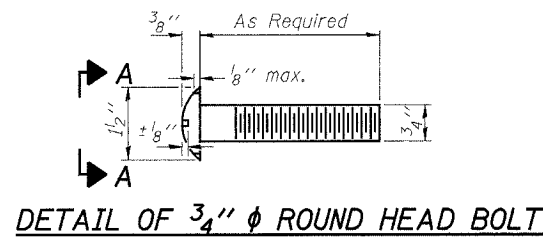

VIEW A-A

4-3/4" ϕ x 6" Round Head Bolts
(With slot or approved recess in
head) with locknut & flat washer.
7/8" ϕ holes in hollow structural
section may be drilled in the field.

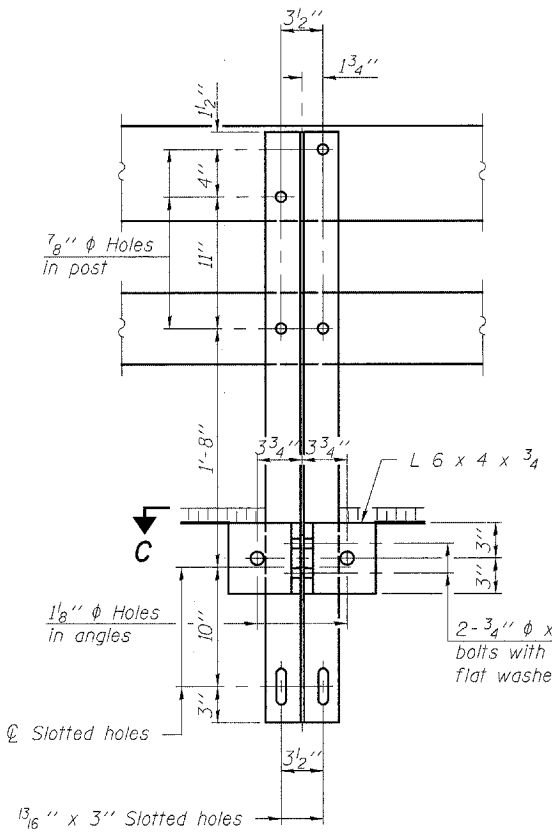

SECTION B-B

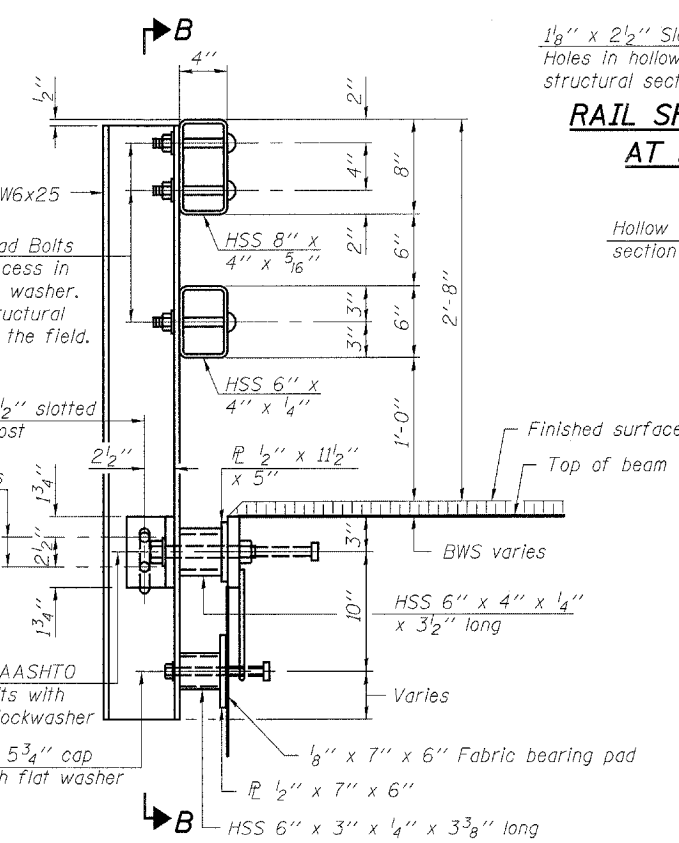

SECTION AT RAIL POST

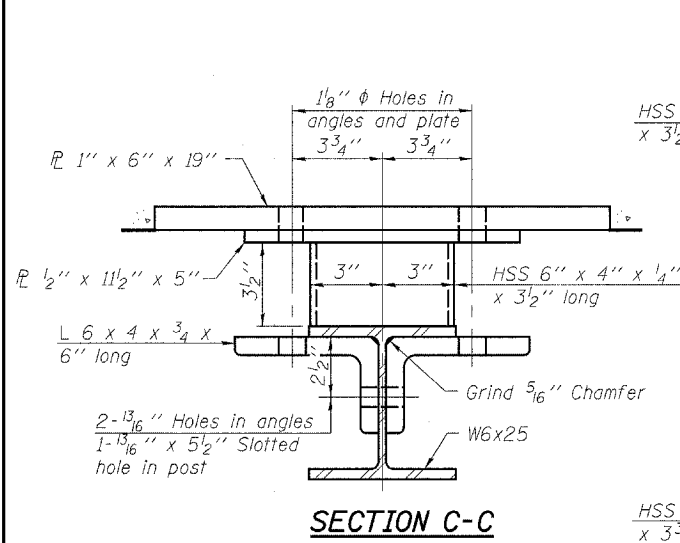

SECTION C-C

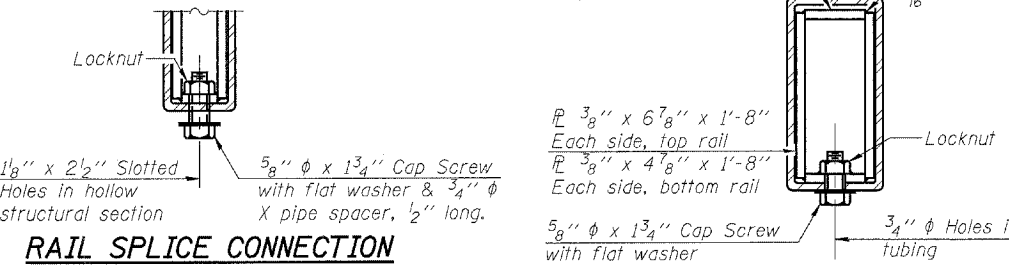

RAIL SPLICE CONNECTION
AT EXPANSION JT.

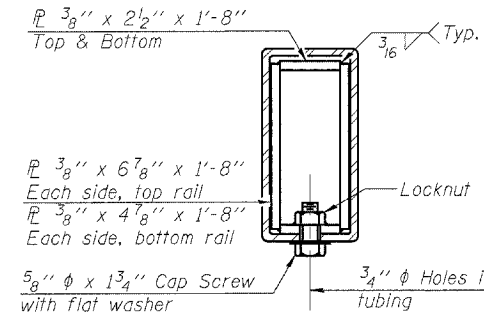

SECTION AT
RAIL SPLICE

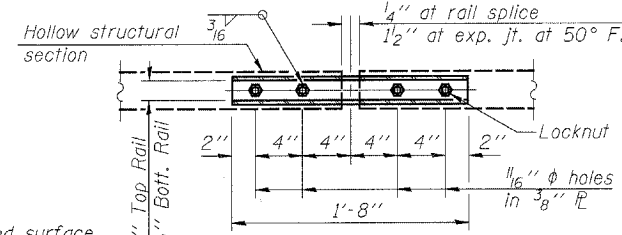

PLAN-BOTT. SPLICE P
TYPICAL

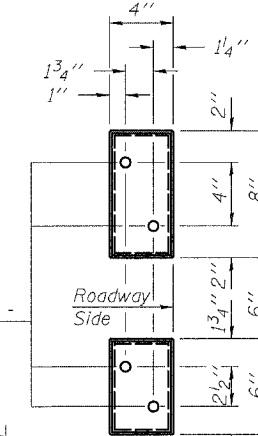

VIEW E-E

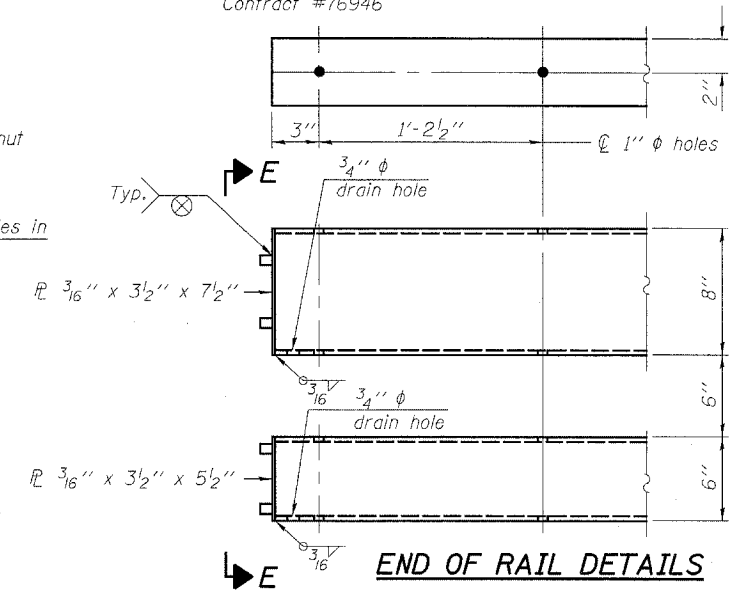

END OF RAIL DETAILS

NOTES

Hollow structural sections shall conform to the requirements of
ASTM designation A 500 Grade B Structural Steel Tubing and shall
meet the longitudinal CVN requirements of 15 ft-lbs at 0° F.
All other steel shapes and plates shall conform to the requirements of
AASHTO M 270 Grade 36 except posts and angles shall conform to
AASHTO M 270, Grade 50.
Bolts, cap screws, and nuts shall conform to the requirements of
ASTM designation A 307 except for high strength bolts, nuts and washers
noted which shall conform to AASHTO M 164.
All bolts, nuts, cap screws, washers and lock washers shall be
galvanized according to AASHTO M 232.
All posts, railing, rail splices, anchor devices and angles shall be
galvanized after shop fabrication according to AASHTO M 111 and
ASTM A 385. Galvanized rail shall not be painted.
Railing shall be according to Section 509 of the Standard
Specifications, except as noted, and will be paid for at the contract
unit price per foot for Steel Bridge Rail, Type SM.
All field drilled holes shall be coated with an approved zinc rich
paint before erection.
For multi-span bridges, sufficient 1/4" x 6" x 1'-2" galvanized
steel shims shall be provided to align rail between adjacent spans.
Cost included with Steel Bridge Rail, Type SM.
The 3/4" ϕ high strength bolts used to connect the 6 x 4 x 3/4
angles to the post shall be tightened according to Article 505.04(f)(2)
of the Standard Specifications. The 1" ϕ high strength bolts connecting
the angles to the concrete shall be tightened to a snug fit and given
an additional 1/8 turn. The 5/8" ϕ cap screws in bottom of posts shall be
tightened to a snug fit only.
For rail post spacing, see sheet 5 and 6 of 9.

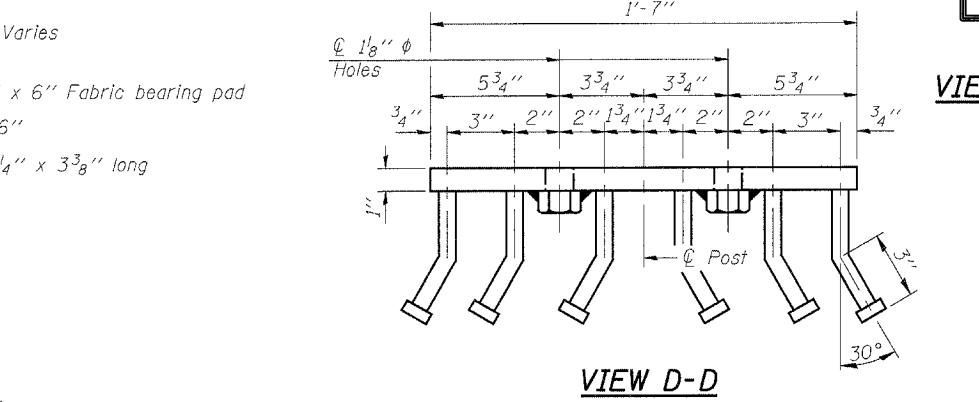

VIEW D-D

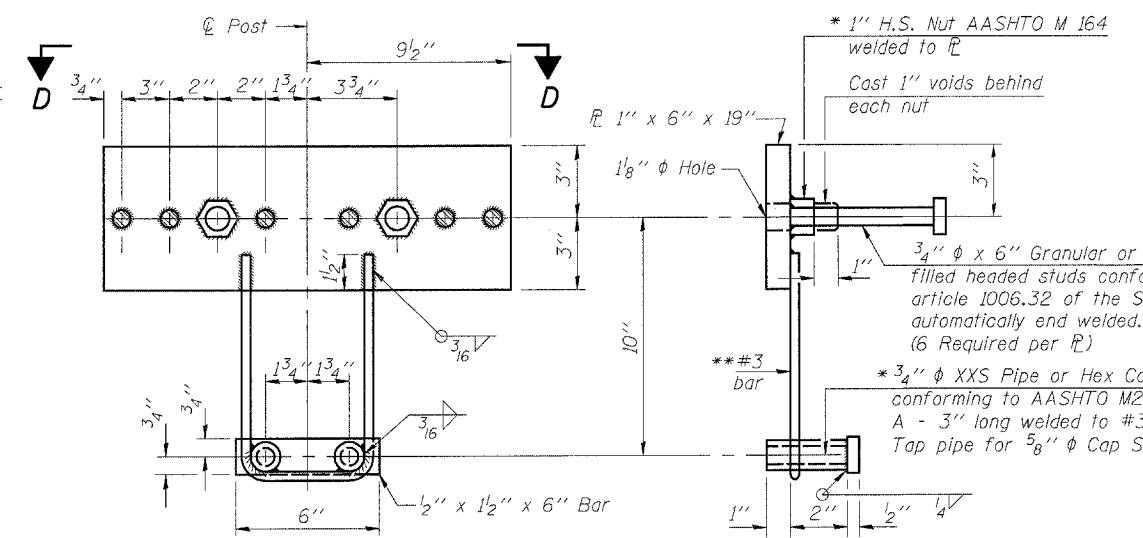

ANCHOR DEVICE

* Threaded areas shall be plugged or blocked off during
casting of beam. Galvanized after fabrication.

** Whenever the lower insert assemblies interfere with
strand locations, the #3 bars shall be cut and adjusted
in order to allow raising or lowering of the lower
inserts. Maximum adjustment not to exceed 1/2".

BILL OF MATERIAL

Item	Unit	Quantity
Steel Bridge Rail, Type SM	Foot	126

TYPE SM
STEEL BRIDGE RAIL SIDE MOUNTED
F.A.P. ROUTE 817 - SECTION 8BR-3
WASHINGTON COUNTY
STATION 36+12.71
STRUCTURE NO. 095-0011

DESIGNED	EML
CHECKED	NJM
DRAWN	EML
CHECKED	NJM

HORNER &
SHIFRIN, INC.
ENGINEERS ARCHITECTS PLANNERS

R-34BWS

10-28-05 (6'-3" Maximum Post Spacing) (1/4" minimum to 3/8" maximum BWS thickness)

Contract #76946

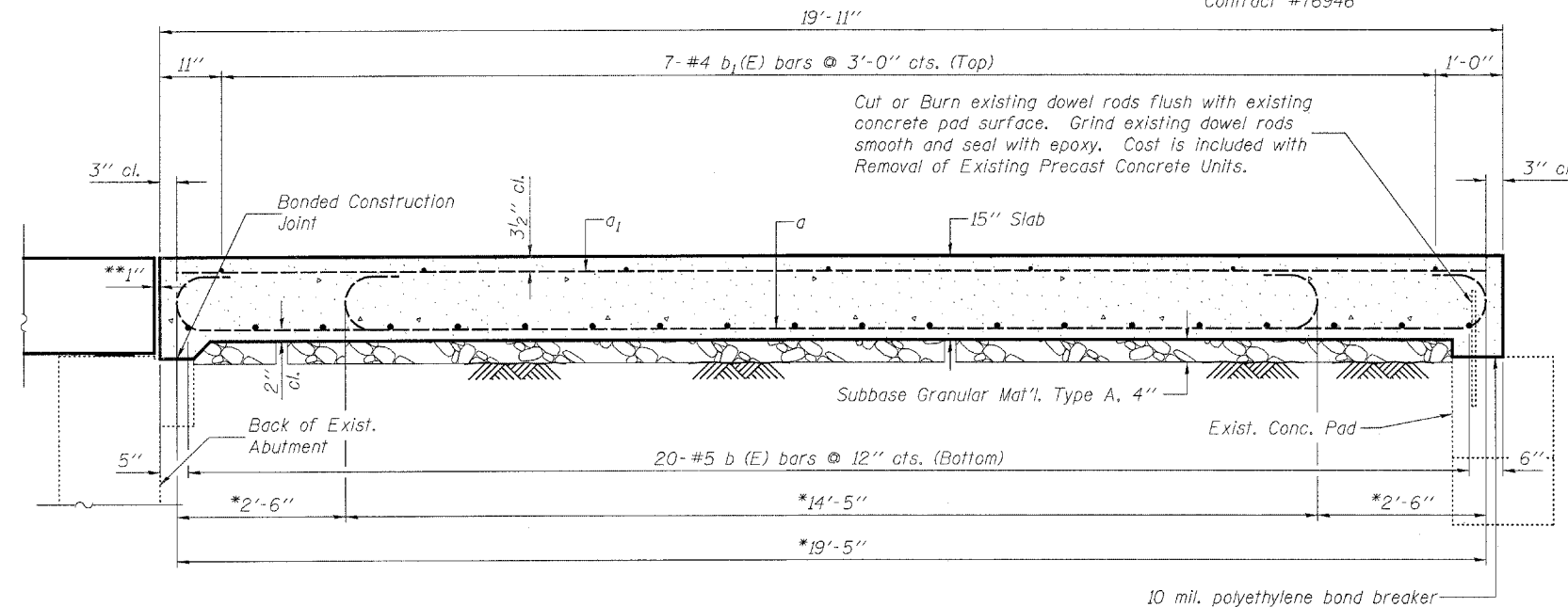
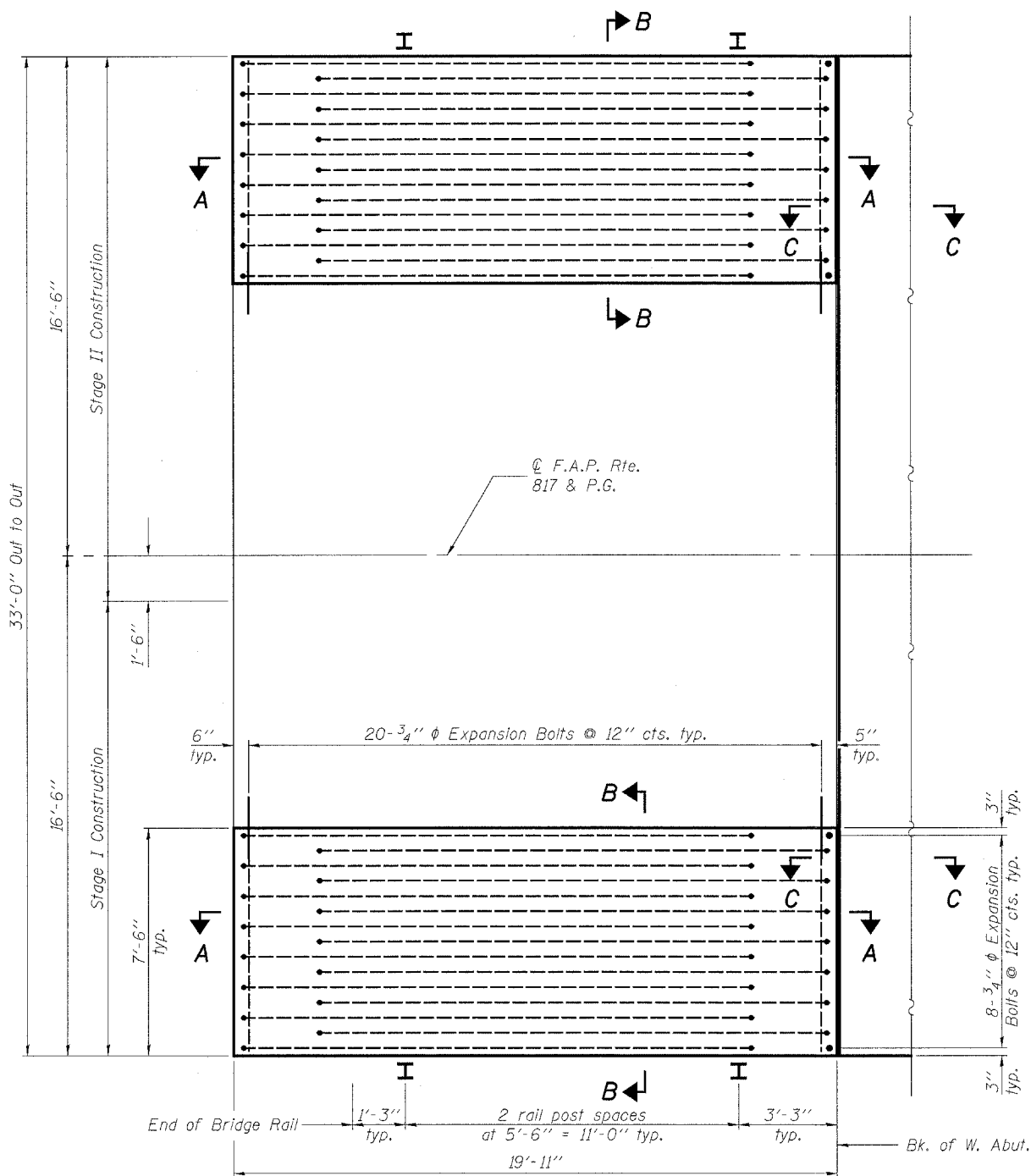

* Stagger No. 9 a bars as shown on plan.
**1" Jt. shall be filled with non-shrink grout. 1" dimension may vary to accommodate tolerance in Precast Prestressed Concrete Deck Beam lengths.

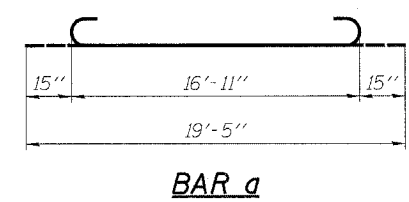
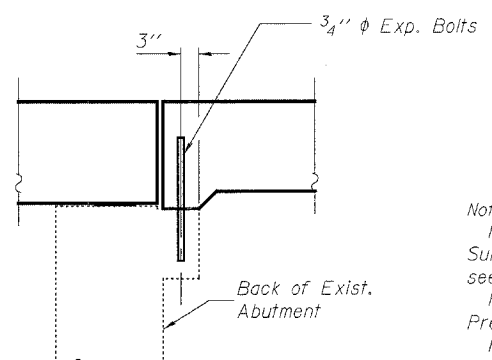
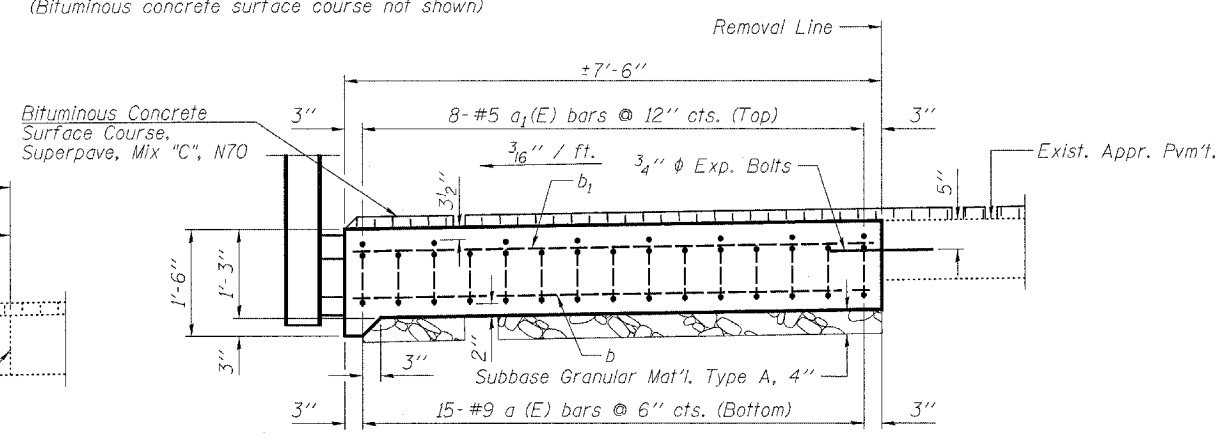
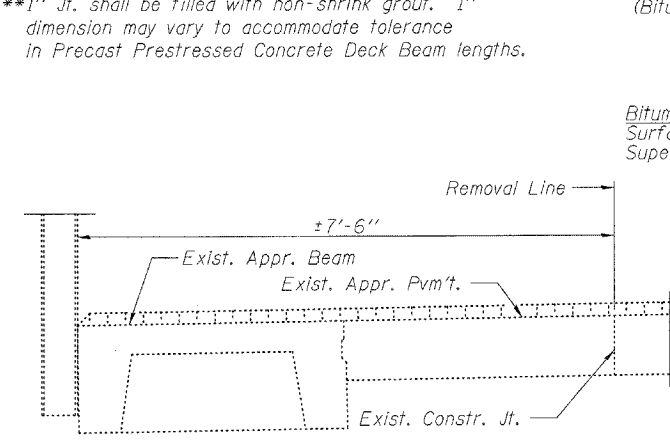

BAR LIST

Bar	No.	Size	Length	Shape
a(E)	60	#9	19'-5"	□
a ₁ (E)	32	#5	19'-5"	—
b(E)	80	#5	7'-3"	—
b ₁ (E)	28	#4	7'-3"	—

BILL OF MATERIAL

Item	Unit	Total
Bridge Approach Pavement (Special)	Sq. Yd.	66
Concrete Removal	Cu. Yd.	9.2
Expansion Bolts 3/4 Inch	Each	112
Removal of Existing Precast Concrete Units	Sq. Ft.	299

Notes:
For quantity of Bituminous Surface Removal and Bituminous Concrete Surface Course, Superpave, Mix "C", N70 on the bridge approach pavement, see roadway plans.
Removal of existing approach beams is included in Removal of Existing Precast Concrete Units.
Removal of existing approach pavement is included with Concrete Removal, Concrete Removal, Removal of Existing Precast Concrete Units and Bridge Approach Pavement (Special) shall occur during its respective stage construction and prior to placement of the new deck beams.
See Special Provisions for Bridge Approach Pavement (Special).
See sheet 4 of 9 for rail anchor device to be cast in approach beams.

BRIDGE APPROACH PAVEMENT (SPECIAL)
F.A.P. ROUTE 817 - SECTION 8BR-3
WASHINGTON COUNTY
STATION 36+12.71
STRUCTURE NO. 095-0011

DESIGNED	EML
CHECKED	NJM
DRAWN	EML
CHECKED	NJM

HORNER & SHIFRIN, INC.
ENGINEERS ■ ARCHITECTS ■ PLANNERS

STATE OF ILLINOIS
DEPARTMENT OF TRANSPORTATION

ROUTE NO.	SECTION	COUNTY	TOTAL SHEETS	SHEET NO.
F.A.P. 817	BBR-2, BBR-3	WASHINGTON	52	46
FED. ROAD DIST. NO. 7	ILLINOIS	FED. AID PROJECT		

SHEET NO. 6

9 SHEETS

Contract #76946

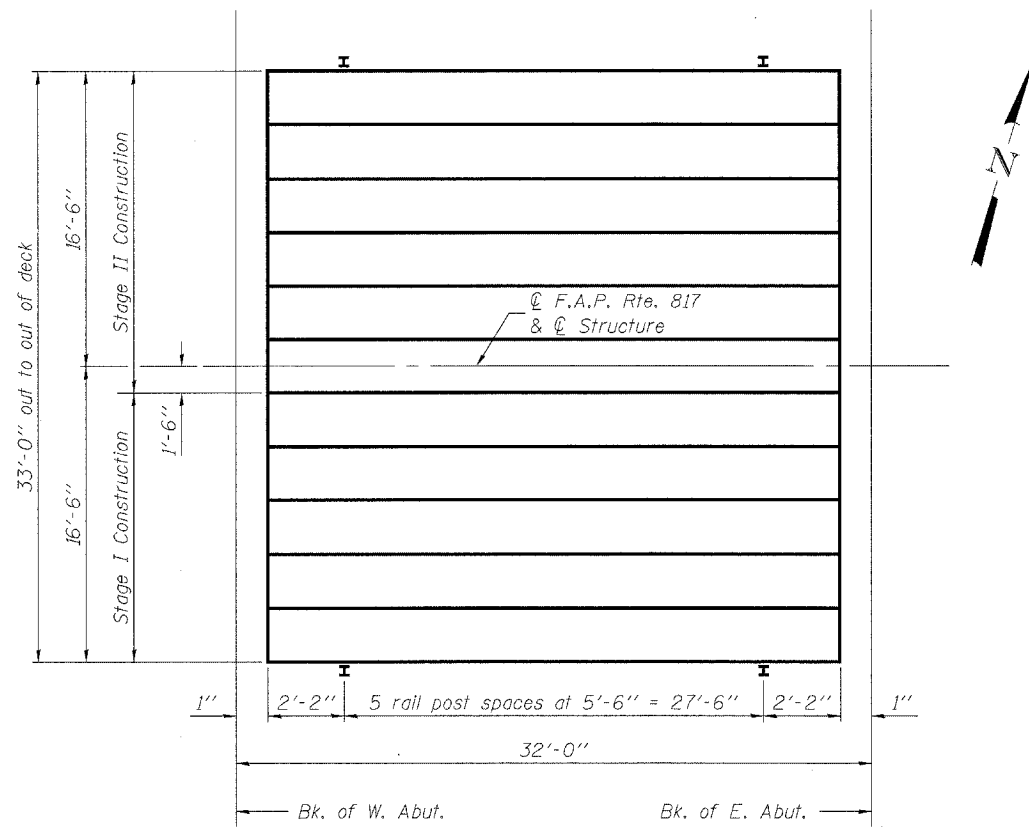

Notes:
Rail spacing the same on both sides of the bridge.
See sheet 5 of 9 for end of bridge rail location.

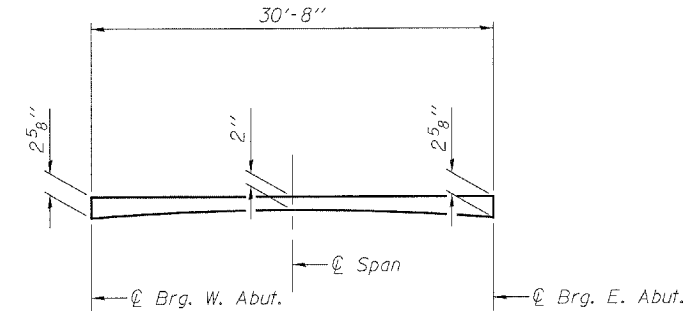

BITUMINOUS CONCRETE SURFACE COURSE PROFILE
(Bituminous concrete surface course along ⊙ Roadway)

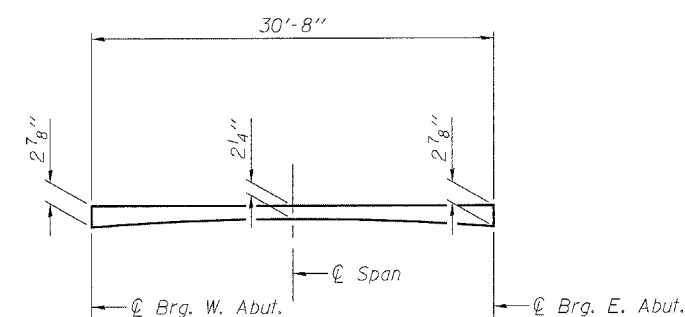

BITUMINOUS CONCRETE SURFACE COURSE PROFILE
(Bituminous concrete surface course along ⊙ Roadway)

Note:
Bituminous Concrete Surface Course Profile dimensions include 1/2" for waterproofing membrane thickness.

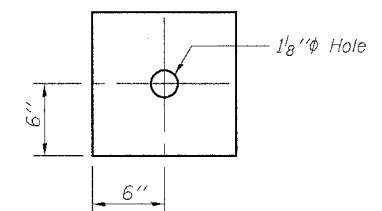
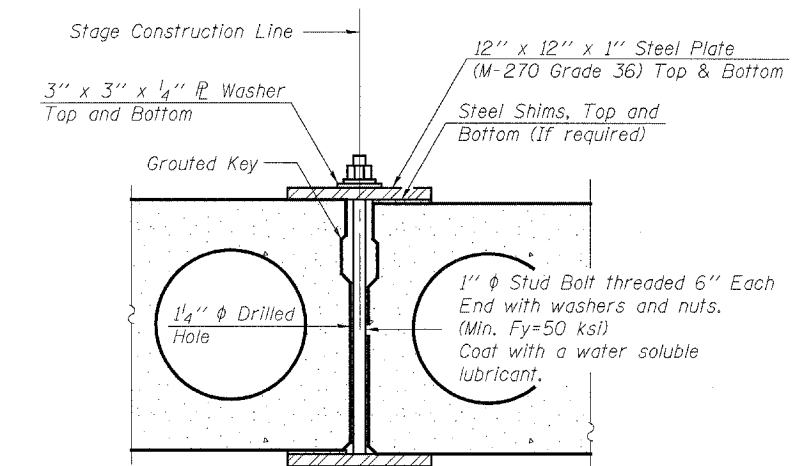
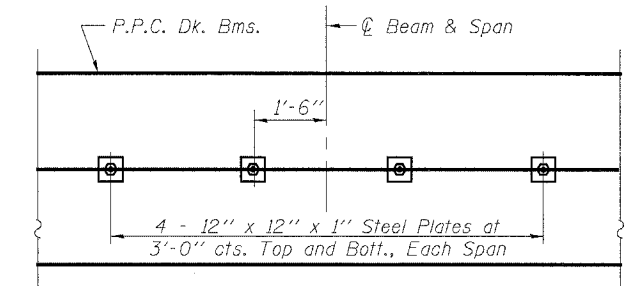

SHEAR KEY CLAMPING DETAILS AT STAGE CONST. JT.

See Special Provisions for Stage Construction of Precast Prestressed Concrete Deck Beams.
Cost included with "Precast Prestressed Concrete Deck Beams".
See Stage Construction Details for traffic lanes.

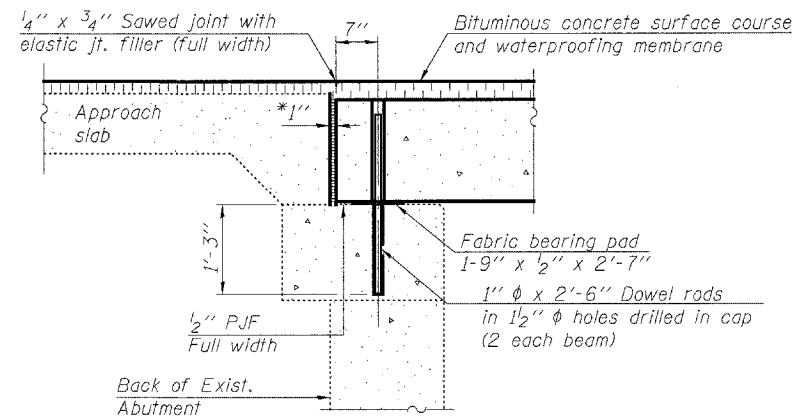

SECTION THRU ABUTMENT

* 1" jt. shall be filled with non-shrink grout. 1" dimension may vary to accommodate tolerance in beam lengths.

Notes:
After beams have been erected, holes shall be drilled into substructure and anchor dowels placed. Dowel holes shall be filled with non-shrink grout to top of beam and allowed to cure min. 24 hrs. prior to grouting the shear keys.
All horizontal dimensions are at right angles to beam ends.
See sheet 7 of 9 for bearing pad details.

DESIGNED	E.M.L.
CHECKED	N.J.M.
DRAWN	E.M.L.
CHECKED	N.J.M.

HORNER & SHIFRIN, INC.
ENGINEERS ■ ARCHITECTS ■ PLANNERS

SUPERSTRUCTURE DETAILS
F.A.P. ROUTE 817 - SECTION 8BR-3
WASHINGTON COUNTY
STATION 36+12.71
STRUCTURE NO. 095-0011

STATE OF ILLINOIS
DEPARTMENT OF TRANSPORTATION

ROUTE NO.	SECTION	COUNTY	TOTAL SHEETS	SHEET NO.	SHEET NO. 7 9 SHEETS
F.A.P. 817	8BR-2, 8BR-3	WASHINGTON	52	47	
FED. ROAD DIST. NO. 7	ILLINOIS	FED. AID PROJECT	Contract #76946		

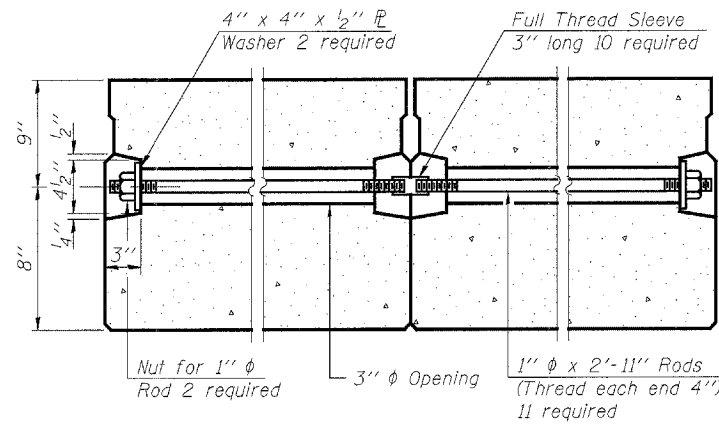
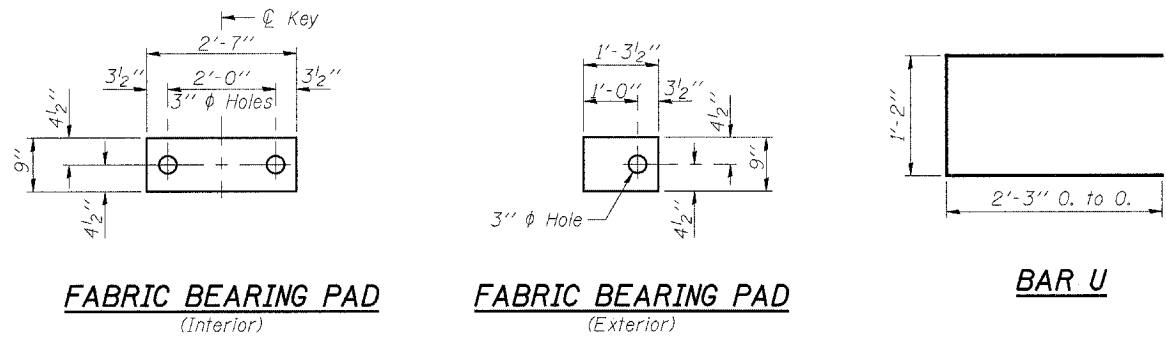

TYPICAL TRANSVERSE TIE ASSEMBLY

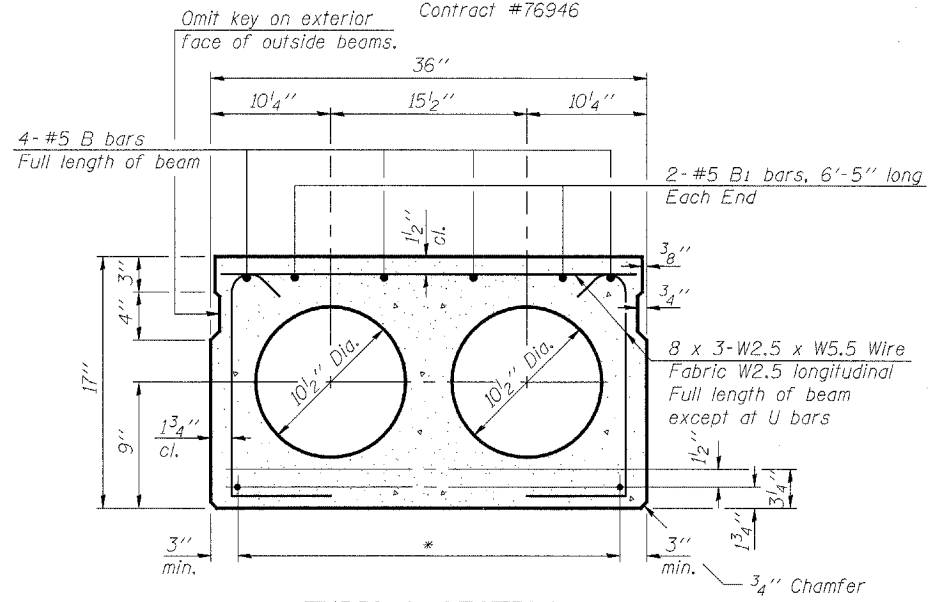

TYPICAL SECTION

- *Transverse Strand Placement Guidelines
1. Place strands symmetrically about centerline of beam.
 2. The minimum distance from center to center of strands in all directions shall be 2".
 3. The minimum clearance from strand to dowel hole shall be 1/2".
 4. The minimum clearance from strand to void shall be 1/2".

Vertical placement of strands shall not be adjusted to satisfy the above guidelines.

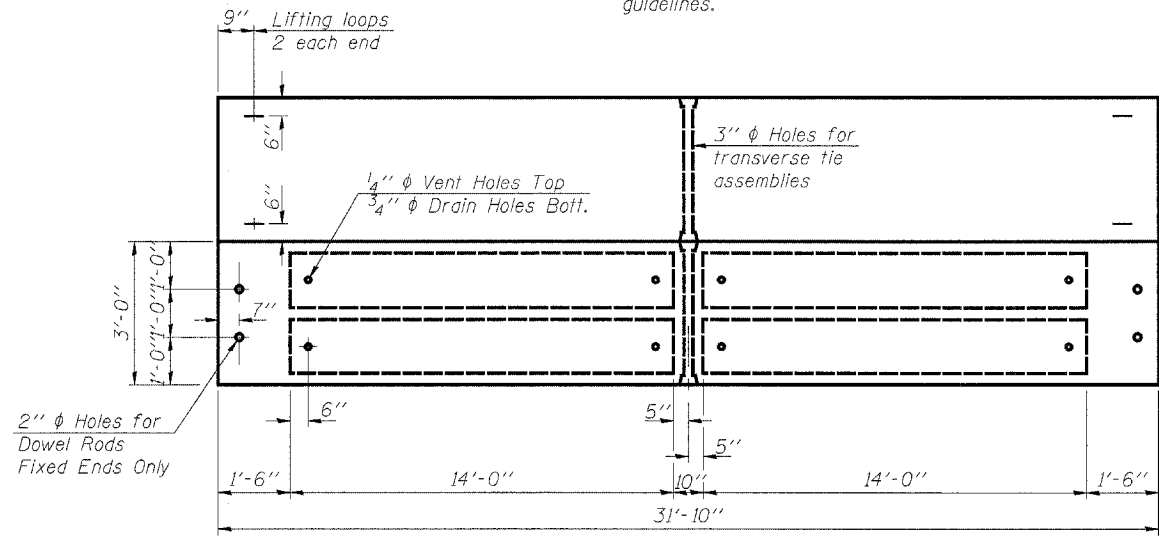

PLAN

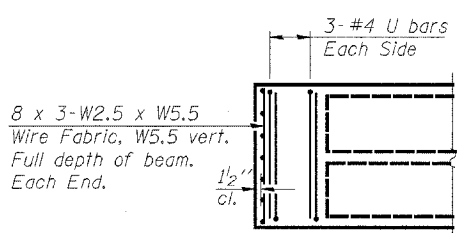

END PLAN

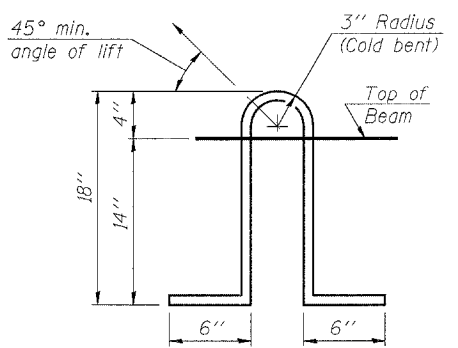

LIFTING LOOP DETAIL

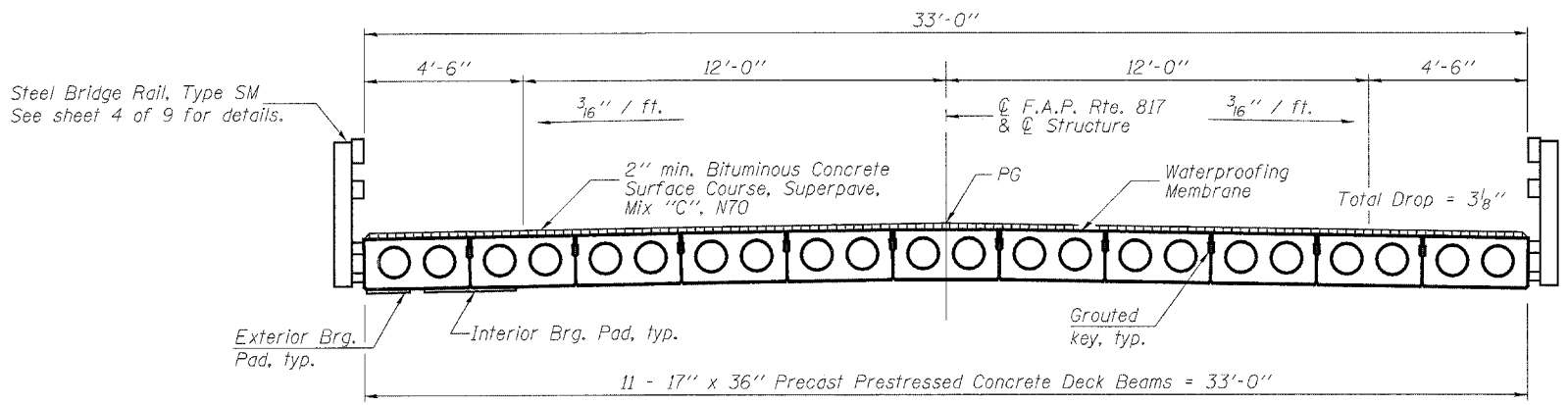

CROSS SECTION

NOTES

Prestressing steel shall be uncoated high strength, low relaxation 7-wire strand, Grade 270. The nominal diameter shall be 1/2" and the nominal cross-sectional area shall be 0.153 sq. in. Lifting loops shall be 2 - 1/2" diameter 270 ksi strands, as shown. The 1" diameter rods in the transverse tie assembly shall be tightened to a snug fit and the threads set. Pockets that receive transverse tie bar on outside shall be filled with grout after transverse tie assembly is in place. The bearing seat surfaces shall be adjusted by shimming to assure firm and even bearing. Two 1/8" fabric adjusting shims of the dimensions of the Exterior Bearing Pad shall be provided for each bearing. Keyway surfaces shall be cleaned to remove form oil or other bond breaking material prior to shipment of the beams. Cleaning shall be done by sandblasting the keyway areas between top of the beam and the bottom edge of the key. Corrosion Inhibitor, as covered in the Special Provisions, shall be used in the concrete for precast prestressed concrete deck beams. Required Release Strength, f'ci, shall be 4,000 p.s.i. See sheet 3 of 9 for Wing Type Threaded Insert location and spacing. See sheet 4 of 9 for rail anchor device to be cast in precast beams. See sheet 6 of 9 for spacing of rail post. See sheet 6 of 9 for Shear Key Clamping Details at Stage Const. Jt.

BILL OF MATERIAL

Item	Unit	Total
Precast Prestressed Concrete Deck Beams (17" Depth)	Sq. Ft.	1051

SUPERSTRUCTURE DETAILS
F.A.P. ROUTE 817 - SECTION 8BR-3
WASHINGTON COUNTY
STATION 36+12.71
STRUCTURE NO. 095-0011

DESIGNED	EML
CHECKED	NJM
DRAWN	EML
CHECKED	NJM

HORNER & SHIFRIN, INC.
ENGINEERS ■ ARCHITECTS ■ PLANNERS

STATE OF ILLINOIS
DEPARTMENT OF TRANSPORTATION

ROUTE NO.	SECTION	COUNTY	TOTAL SHEETS	SHEET NO.
F.A.P. 817	8BR-2, 8BR-3	WASHINGTON	52	48
FED. ROAD DIST. NO. 7	ILLINOIS	FED. AID PROJECT		

SHEET NO. 8

9 SHEETS

Contract #76946

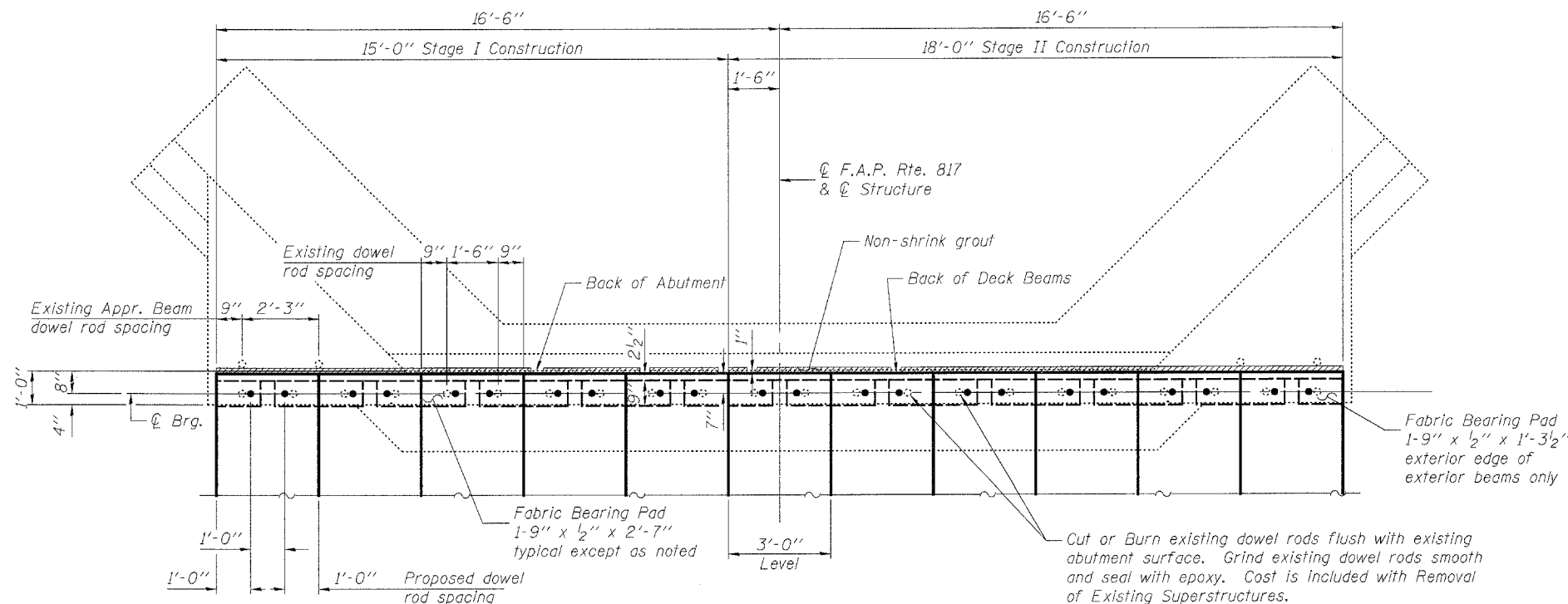

PLAN - WEST ABUTMENT

(Bituminous concrete surface course not shown)

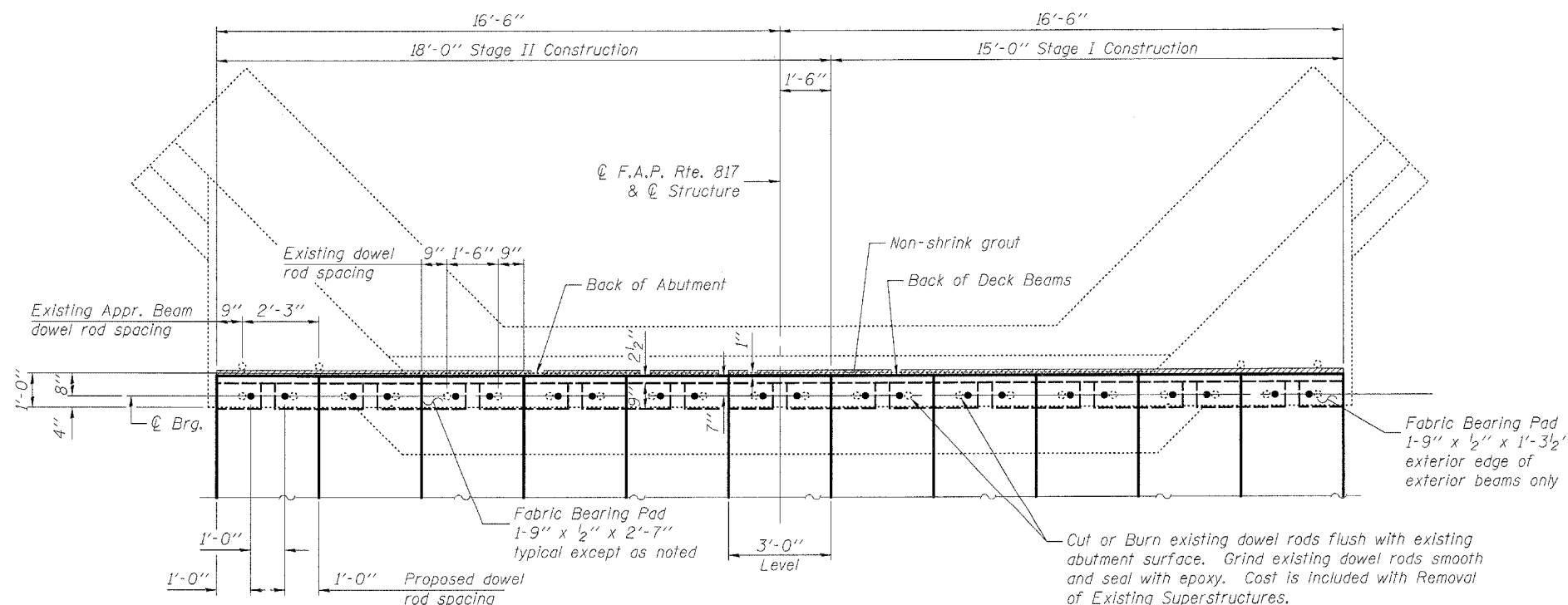

PLAN - EAST ABUTMENT

(Bituminous concrete surface course not shown)

DESIGNED	EML
CHECKED	NJM
DRAWN	EML
CHECKED	NJM

HORNER & SHIFRIN, INC.
ENGINEERS ■ ARCHITECTS ■ PLANNERS

Note: For Abutment Repair details see sheet 9 of 9.

ABUTMENTS
F.A.P. ROUTE 817 - SECTION 8BR-3
WASHINGTON COUNTY
STATION 36+12.71
STRUCTURE NO. 095-0011

STATE OF ILLINOIS
DEPARTMENT OF TRANSPORTATION

ROUTE NO.	SECTION	COUNTY	TOTAL SHEETS	SHEET NO.	SHEET NO. 9 9 SHEETS
F.A.P. 817	BBR-2, BBR-3	WASHINGTON	52	49	
FED. ROAD DIST. NO. 7	ILLINOIS	FED. AID PROJECT-			

Contract #76946

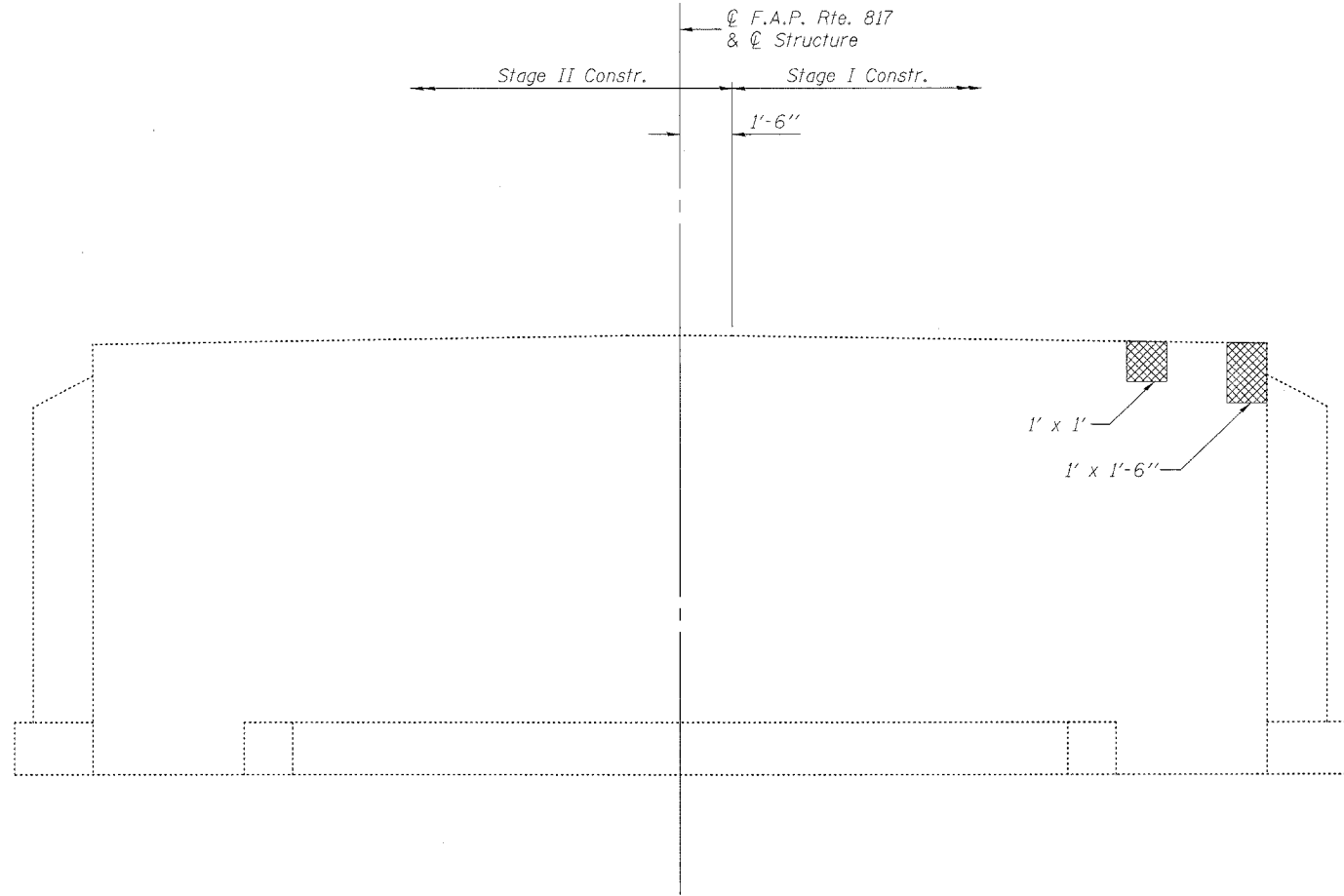

ELEVATION - EAST ABUTMENT
(Looking East)

A ←

A ←

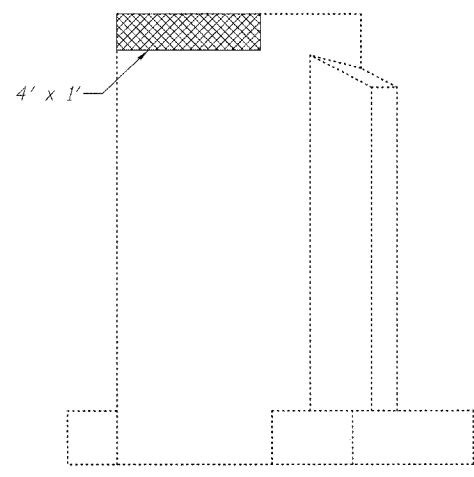

VIEW A-A

BILL OF MATERIAL

Item	Unit	Total
Structural Repair of Concrete (Depth Equal to or less than 5')	Sq. Ft.	6.5

LEGEND

▨ Structural Repair of Concrete

Notes:
Concrete Removal and Structural Repair of Concrete shall occur during its respective stage construction.
See Special Provisions for Structural Repair of Concrete.
No Structural Repair of Concrete required for the West Abutment.

DESIGNED	EML
CHECKED	NJM
DRAWN	EML
CHECKED	NJM

HORNER & SHIFRIN, INC.
ENGINEERS ■ ARCHITECTS ■ PLANNERS

ABUTMENT REPAIR DETAILS
F.A.P. ROUTE 817 - SECTION 8BR-3
WASHINGTON COUNTY
STATION 36+12.71
STRUCTURE NO. 095-0011

F.A.P. RTE.	SECTION	COUNTY	TOTAL SHEETS	SHEET NO.
817	88R-3	WASHINGTON	52	50
STA. 33+50.00		TO STA. 35+00.00		
FED. ROAD DIST. NO. _____		ILLINOIS FED. AID PROJECT		

FINAL SURVEY SUPERVIEWED BY DATE
 NOTE BOOK SURVIL TEMPLATE
 AREAS CHECKED
 NO. _____

ORIGINAL SURVIL SUPERVIEWED BY DATE
 NOTE BOOK SURVIL TEMPLATE
 AREAS CHECKED
 NO. _____

PLOT DATE = 6/29/2006
 FILE NAME = o:\projects\88r3\plan\sheet\88r3\88r3.dwg
 PLOT SCALE = 1/8"=1'-0"
 USER NAME = overby

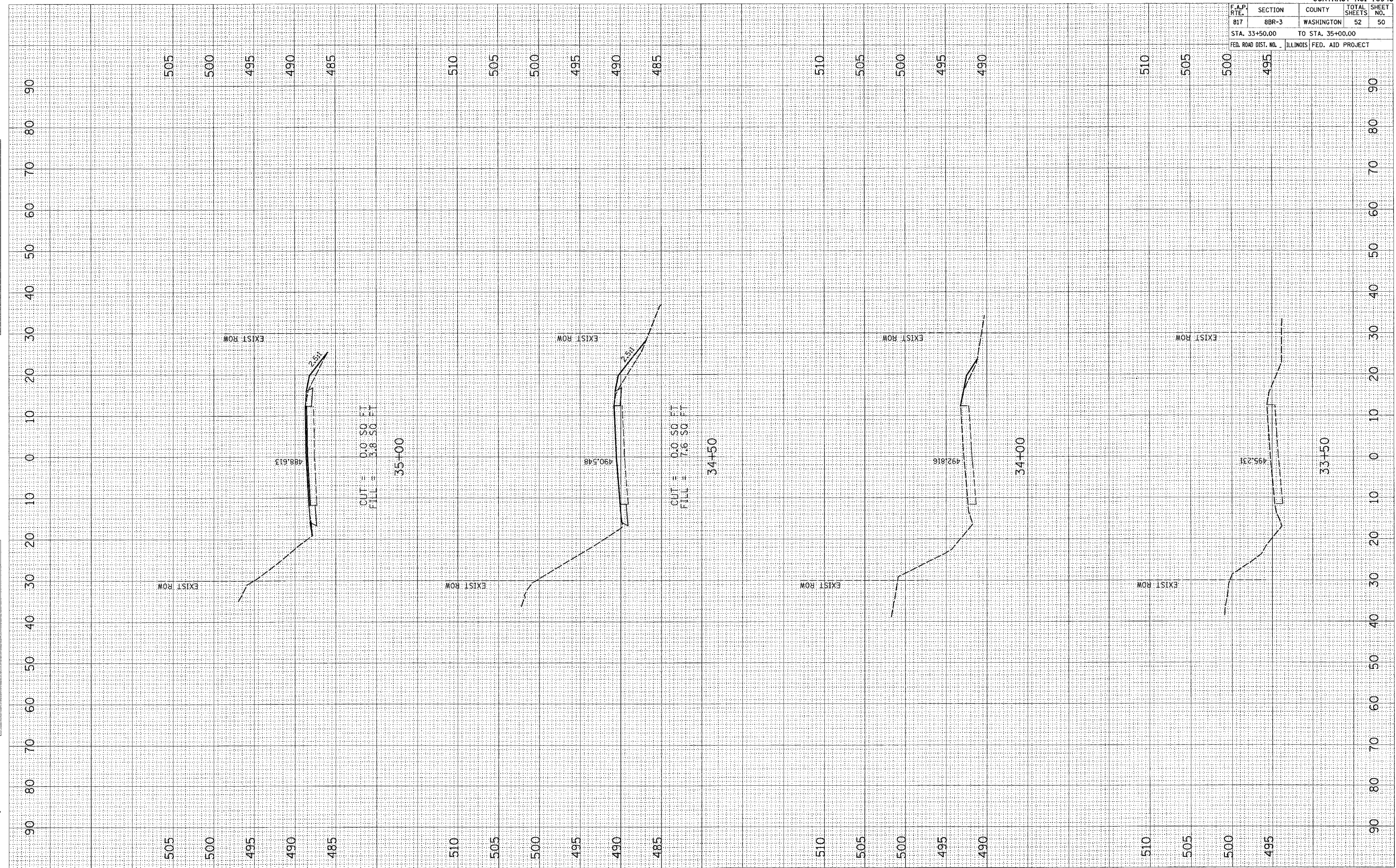

F.A.P. RTE.	SECTION	COUNTY	TOTAL SHEETS	SHEET NO.
817	88R-3	WASHINGTON	52	51
STA. 35+50.00		TO STA. 38+00.00		
FED. ROAD DIST. NO. _____		ILLINOIS FED. AID PROJECT		

FINAL SURVEY	DATE
BY	
REVIEWED	
TEMPLATE	
AREAS CHECKED	
NO.	

ORIGINAL SURV.	DATE
BY	
REVIEWED	
TEMPLATE	
AREAS CHECKED	
NO.	

PLOT DATE = 6/25/2006
 FILE NAME = c:\pro\pccs\ed8885\plan\ssah\8885\8885.dwg
 PLOT SCALE = 10.00000' / 1" IN.
 USER NAME = overby

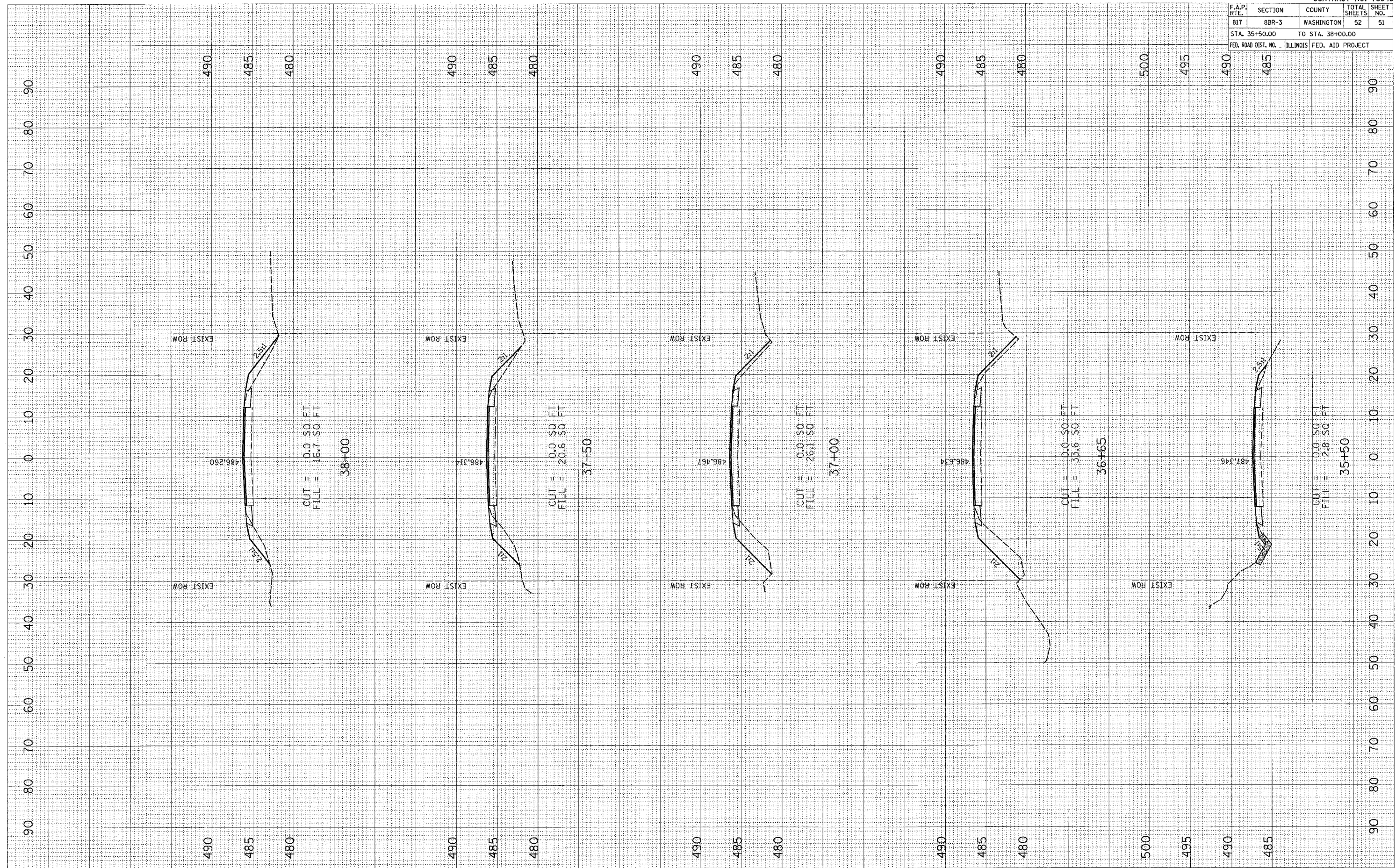

F.A.P. RTE.	SECTION	COUNTY	TOTAL SHEETS	SHEET NO.
817	8BR-3	WASHINGTON	52	52
STA. 38+50.00 TO STA. 39+50.00				
FED. ROAD DIST. NO. ILLINOIS		FED. AID PROJECT		

FINAL SURVEY NO. _____

SURVEY PLOTTED _____

NOTE BOOK _____

AREAS CHECKED _____

BY _____

DATE _____

ORIGINAL SURVEY NO. _____

SURVEY PLOTTED _____

AREAS CHECKED _____

BY _____

DATE _____

PLOT DATE = 6/24/2006
 FILE NAME = c:\projet\805\805\plan\wash\805plan.dwg
 USER = 10/08/06 / J. IN.
 USER NAME = joverly

