

**INDEX OF SHEETS**

- SHEET NO.
- COVER SHEET
  - LEGEND, GENERAL NOTES AND SUMMARY OF QUANTITIES
  - TYPICAL SECTIONS
  - 63RD STREET PLAN (STA 0+00 TO VIRGINIA DRIVE)
  - 63RD STREET PLAN (RIDGE ROAD TO RICHMOND AVENUE)
  - RICHMOND AVENUE PLAN (63RD STREET TO STA. 10+00)
  - RICHMOND AVENUE PLAN (STA. 10+00 TO 19+35)
  - OGDEN AVENUE PLAN (WILLIAMS STREET TO GRANT STREET)
  - CHICAGO AVENUE PLAN (VILLAGE LIMITS TO STA 10+46)
  - CHICAGO AVENUE PLAN (STA 10+46 TO GRANT STREET)
  - CUMNOR ROAD PLAN (61ST STREET TO STA 10+18)
  - CUMNOR ROAD PLAN (STA 10+18 TO 59TH STREET)
  - MISCELLANEOUS DETAILS (1 OF 2)
  - MISCELLANEOUS DETAILS (2 OF 2)
  - TRAFFIC CONTROL AND PROTECTION FOR SIDE ROADS, INTERSECTIONS, AND DRIVEWAYS
  - DISTRICT ONE TYPICAL PAVEMENT MARKINGS

**CONTACT**

VILLAGE OF WESTMONT ENGINEERING DIVISION CONTACT: NORIEL NORIEGA OFFICE: 630-829-4465 FAX: 630-829-4469 24 HR: 630-968-2151	BURNS & MCDONNELL CONTACT: ANTHONY BRYANT OFFICE: 630-724-3200 FAX: 630-724-3201	IDOT CONTACT: ROBERT KOLAR OFFICE: 630-407-6900 FAX: 630-407-6901	DUDOT CONTACT: ROBERT KOLAR OFFICE: 630-407-6900 FAX: 630-407-6901
--	---	--	---

**STATE STANDARDS**

- 000001-04 STANDARD SYMBOL, ABBREVIATIONS AND PATTERNS
- 424001-04 CURB RAMPS FOR SIDEWALKS
- 701801-03 LANE CLOSURE, MULTILANE, 1W OR 2W CROSSWALK OR SIDEWALK CLOSURE
- 702001-06 TRAFFIC CONTROL DEVICES

**LENGTH OF PROJECT**

PROJECT LENGTH GROSS = 1.70 MILES (8,983 FT.)  
NET = 1.48 MILES (7,843 FT.)

**DESIGN DESIGNATION - SIDEWALK**

**TRAFFIC DATA**

OGDEN AVE. ADT = 36,300  
SPEED LIMIT = 35 MPH

63rd STREET ADT = <25,000  
SPEED LIMIT = 40 MPH

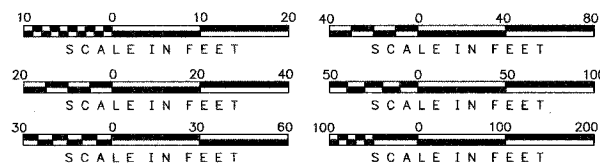

FULL SIZE PLANS HAVE BEEN PREPARED USING STANDARD ENGINEERING SCALES. REDUCED SIZED PLANS WILL NOT CONFORM TO STANDARD SCALES, IN MAKING MEASUREMENT ON REDUCED PLANS, THE ABOVE SCALES MAY BE USED.

**CONTRACT NO.: 83851**

STATE OF ILLINOIS  
DEPARTMENT OF TRANSPORTATION  
DIVISION OF HIGHWAYS

**PLANS FOR PROPOSED  
FEDERAL AID HIGHWAY**

MISCELLANEOUS SIDEWALKS  
Ogden Avenue (FAP311), 63rd Street (FAU1518), Richmond Avenue,  
Chicago Avenue (FAU1486) and Cumnor Road  
PROJECT NO.: CMF-0311(029)  
SECTION NO.: 06-00096-00-SW  
VILLAGE OF WESTMONT  
DU PAGE COUNTY  
JOB NO.: C-91-296-06

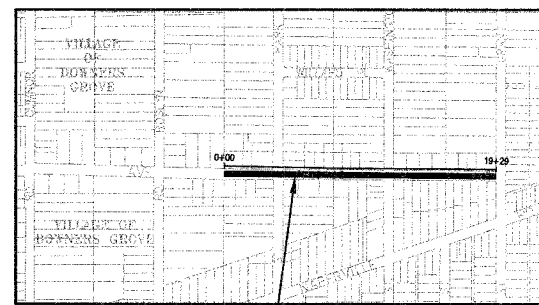
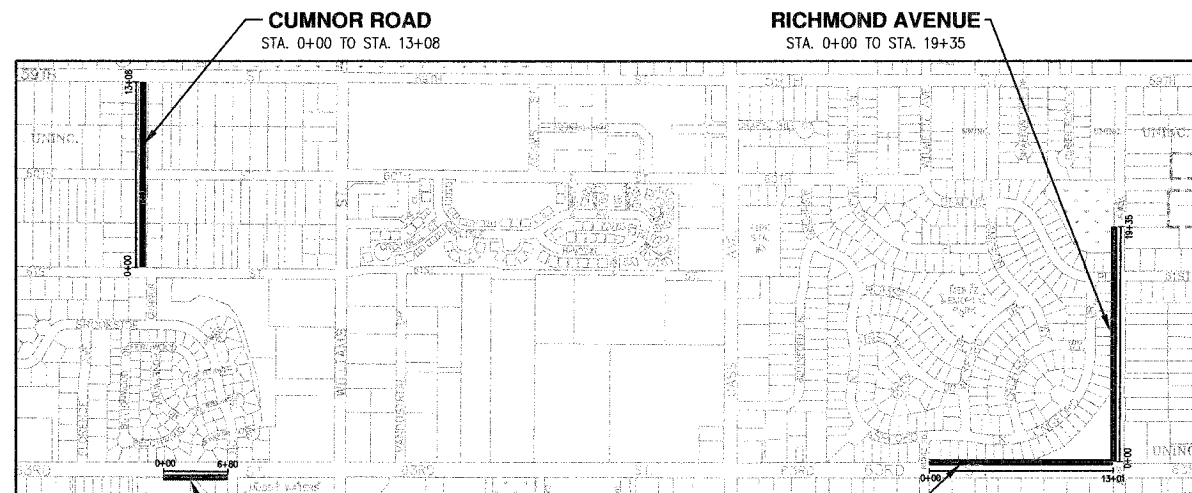

**CHICAGO AVENUE**  
STA. 0+00 TO STA. 19+29

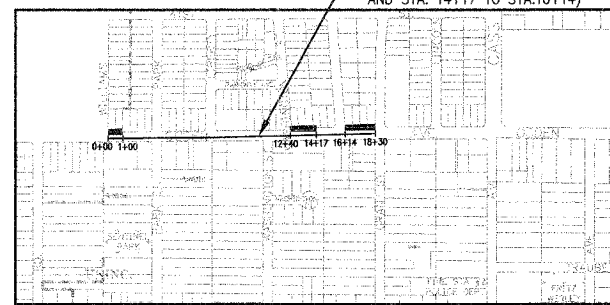

**OGDEN AVENUE**  
STA. 0+00 TO STA. 18+30  
(COMMISSION STA 1+00 TO STA. 12+40  
AND STA. 14+17 TO STA. 16+14)

TOWNSHIP: 38 DOWNERS GROVE TOWNSHIP NORTH  
RANGE: 11



IL DESIGN FIRM NO.  
184-001310

F.A.P. RTE.	SECTION	COUNTY	TOTAL SHEETS	SHEET NO.
-	06-00096-00-SW	DU PAGE	16	1
FEDERAL RD. DIST. NO.		ILLINOIS	FEDERAL AID PROJECT	
CONTRACT: 83851				



**CALL  
J.U.L.I.E.  
BEFORE YOU DIG  
1-800-892-0123**

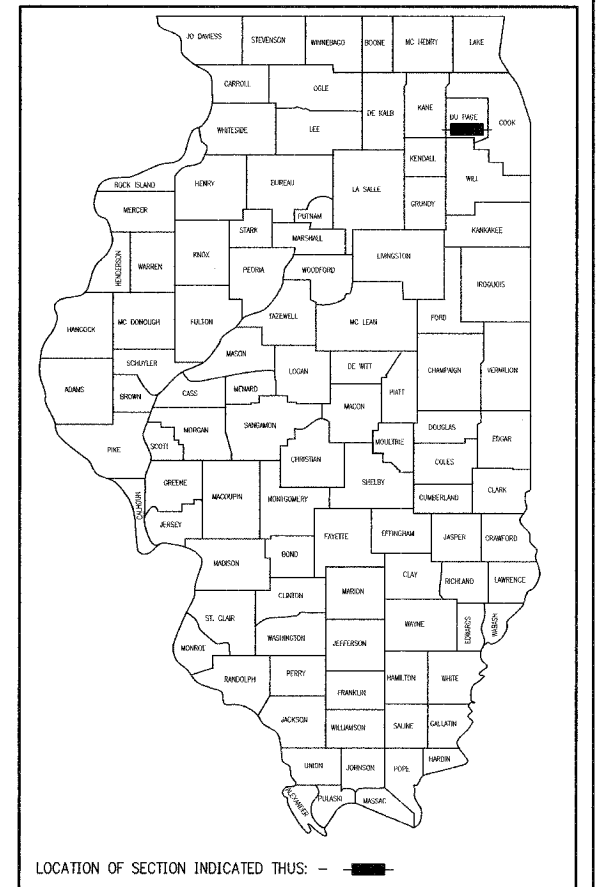

LOCATION OF SECTION INDICATED THIS: -

STATE OF ILLINOIS  
DEPARTMENT OF TRANSPORTATION  
DIVISION OF HIGHWAYS

APPROVED MARCH 24 2006  
NORIEL NORIEGA  
VILLAGE ENGINEER

PASSED APRIL 6 2006  
CHRIS HOLT  
ENGINEER OF LOCAL ROADS AND STREETS

SIGNED April 10 2006  
Piane M. O'Keefe / CBJ  
DEPUTY DIRECTOR OF HIGHWAYS  
REGION ENGINEER



ANTHONY J. BRYANT, P.E.  
NO. 062-056612  
EXP. DATE: 11/30/2007

**PRINTED BY THE AUTHORITY  
OF THE STATE OF ILLINOIS**

I.D.O.T. FEDERAL AID DESIGN ENGINEER: ABIGAIL BRINKS TEL: 847-705-4233  
CONSULTANTS: BURNS & MCDONNELL ENGINEERING, CO. 630-990-0300

F.A.P. RTE.	SECTION	COUNTY	TOTAL SHEETS	SHEET NO.
-	06-00096-00-SW	DU PAGE	16	2
FEDERAL RD. DIST. NO.	ILLINOIS	FEDERAL AID PROJECT		
CONTRACT: 63851				

**LEGEND**

- EXISTING FENCE
- EXISTING R.O.W.
- PROPOSED FENCE
- LIMITS OF TOP SOIL AND SOD
- TREE LINE
- LIGHT POLE
- ELECTRIC TRANSFORMER
- ELECTRICAL TRANSFORMER W/CONC. PAD
- TRAFFIC SIGNAL
- POWER POLE
- GUY WIRE
- TELEPHONE PEDESTAL
- HANDHOLE
- FIRE HYDRANT
- LANDSCAPE STONE
- STORM SEWER INLET
- TREE STUMP
- TREE OR SHRUB
- PROPERTY PIPE (FOUND)
- SIGN
- CONTROL POINT (PK-NAIL)
- BENCHMARK

**SUMMARY OF QUANTITIES**

CODE NO.	ITEM	UNIT	SFTY-1B
20100110	TREE REMOVAL (6 TO 15 UNITS DIAMETER)	UNIT	33
20100210	TREE REMOVAL (OVER 15 UNITS DIAMETER)	UNIT	36
20101200	TREE ROOT PRUNING	EACH	15
20101300	TREE PRUNING (1 TO 10 INCH DIAMETER)	EACH	3
20101350	TREE PRUNING (OVER 10 INCH DIAMETER)	EACH	3
20201200	REMOVAL AND DISPOSAL OF UNSUITABLE MATERIAL	CU YD	980
21101615	TOPSOIL FURNISH AND PLACE, 4"	SQ YD	5355
25000400	NITROGEN FERTILIZER NUTRIENT	POUND	68
25000500	PHOSPHORUS FERTILIZER NUTRIENT	POUND	68
25000600	POTASSIUM FERTILIZER NUTRIENT	POUND	68
25200110	SODDING, SALT TOLERANT	SQ YD	5425
25200200	SUPPLEMENTAL WATERING	UNIT	270
28000400	PERIMETER EROSION BARRIER	FOOT	530
42400200	PORTLAND CEMENT CONCRETE SIDEWALK 5 INCH	SQ FT	35,605
44000200	DRIVEWAY PAVEMENT REMOVAL	SQ YD	823
44000600	SIDEWALK REMOVAL	SQ FT	675
44001700	COMBINATION CONCRETE CURB & GUTTER REMOVAL AND REPLACEMENT	FOOT	35
42400800	DETECTABLE WARNING	SQ FT	970
* 56500600	DOMESTIC WATER SERVICE BOX TO BE ADJUSTED	EACH	2
60265700	VALVE VAULTS TO BE ADJUSTED	EACH	1
70102640	TRAFFIC CONTROL AND PROTECTION, STANDARD 701801	L SUM	1
* 78000400	THERMOPLASTIC PAVEMENT MARKING - LINE 6"	FOOT	317
* 78000650	THERMOPLASTIC PAVEMENT MARKING - LINE 24"	FOOT	51
* B1400115	HANDHOLE TO BE ADJUSTED	EACH	1
X0322494	CURB CUT	FOOT	147
* X0322923	SEGMENTAL CONCRETE BLOCK WALL	SQ FT	1815
* XX000882	WOOD FENCE	FOOT	526
XX004090	SHRUB REMOVAL	EACH	13
XX004393	BITUMINOUS DRIVEWAY REPLACEMENT, 2"	SQ YD	663
XX004847	STONE DRIVEWAY REMOVAL	SQ YD	73
XX004848	STONE DRIVEWAY REPLACEMENT	SQ YD	51
67100100	Mobilization	L SUM	1

\*SPECIALTY ITEM

**BITUMINOUS MIXTURE REQUIREMENTS**

PAY ITEM	AC TYPE	VOIDS	MAX RAP%
BITUMINOUS DRIVEWAY REPLACEMENT BIT. CONC. SURFACE COURSE, SUPERPAVE, MIX C, N 50	PG 64-22	4% @ 50 GYR	15

UNIT WEIGHT FOR ALL BITUMINOUS SURFACE MIX IS 112 LBS/SQ YD/IN

**GENERAL NOTES**

- THE CONTRACTOR SHALL NOTIFY J.U.L.I.E. (800-892-0123) AT LEAST 48 HOURS PRIOR TO CONSTRUCTION FOR LOCATIONS OF UTILITIES, AND SHALL BE RESPONSIBLE FOR THE PROTECTION OF THE SAME.
- THE CONTRACTOR SHALL NOTIFY THE DUPAGE COUNTY DIVISION OF TRANSPORTATION (630-407-6900) A MINIMUM OF 48 HOURS PRIOR TO THE START OF CONSTRUCTION WITHIN THE COUNTY'S RIGHT OF WAY AND WITHIN 300' OF ANY COUNTY MAINTAINED SIGNAL. TRAFFIC SIGNALS AND RELATED EQUIPMENT ARE NOT ON THE J.U.L.I.E. SYSTEM.
- THE CONTRACTOR SHALL NOTIFY THE ENGINEER AND THE VILLAGE OF WESTMONT AT LEAST 48 HOURS IN ADVANCE OF CONSTRUCTION. NO UNDERGROUND WORK SHALL BE COVERED UNTIL IT HAS BEEN INSPECTED. APPROVAL TO PROCEED AFTER BE OBTAINED FROM THE ENGINEER PRIOR TO POURING ANY CONCRETE AFTER FORMS HAVE BEEN SET. THE CONTRACTOR IS RESPONSIBLE FOR OBTAINING ALL NECESSARY PERMITS FROM DUPAGE COUNTY D.O.T.
- WRITTEN DIMENSIONS ON THESE DRAWINGS SHALL TAKE PRECEDENCE OVER SCALED DIMENSIONS. CONTRACTORS SHALL VERIFY AND BE RESPONSIBLE FOR ALL ELEVATIONS, DIMENSIONS, AND CONDITIONS ON THE JOB. THE ENGINEER SHALL BE NOTIFIED AS SOON AS POSSIBLE OF ANY VARIATIONS FROM THE DIMENSIONS AND CONDITIONS SHOWN ON THESE DRAWINGS.
- ALL WORK FOR WHICH THERE IS NO SPECIFIC PAY ITEM SHALL BE CONSIDERED INCIDENTAL TO THE CONTRACT AND NO SEPARATE PAYMENT SHALL BE MADE WITH RESPECT TO INCIDENTAL WORK.
- ANY DELAY OR EXTRA COST TO THE CONTRACTOR CAUSED BY PIPELINES OR OTHER UNDERGROUND STRUCTURES OR OBSTRUCTIONS WHICH ARE NOT SHOWN ON THE DRAWINGS OR FOUND IN LOCATIONS DIFFERENT FROM THOSE INDICATED, SHALL NOT CONSTITUTE A CLAIM FOR EXTRA WORK, ADDITIONAL PAYMENT, OR DAMAGES AND SHALL BE CONSIDERED INCIDENTAL TO THE CONTRACT.
- THE CONTRACTOR SHALL BE RESPONSIBLE FOR THE PROTECTION OF ALL PUBLIC AND PRIVATE UTILITIES, EVEN THOUGH THEY MAY NOT BE SHOWN ON THE DRAWINGS. ANY UTILITY DAMAGES DURING CONSTRUCTION SHALL BE REPAIRED OR REPLACED TO THE SATISFACTION OF THE OWNER AT THE CONTRACTOR'S EXPENSE.
- THE CONTRACTOR SHALL BE RESPONSIBLE FOR REMOVING IMMEDIATELY ANY MUD, DIRT, OR DEBRIS DEPOSITED ON ROADWAYS FROM ANY VEHICLES EXITING OR ENTERING THE SITE.
- IT IS THE CONTRACTORS RESPONSIBILITY TO GUARD AND PROTECT NEWLY POURED CONCRETE AGAINST ANY FOREIGN MARKINGS, GRAFFITI OR OTHER DAMAGE, AND AT HIS EXPENSE, REPLACE ANY SIDEWALK NOT ACCEPTABLE TO THE ENGINEER.
- ON 63rd STREET AND OGDEN AVENUE DAILY LANE CLOSURES ARE PERMITTED BETWEEN 9:00 A.M. AND 4:00 P.M. ONLY. OTHER LANE CLOSURES SHALL BE RESTRICTED TO THE HOURS OF 8:00 A.M. TO 5:00 P.M. ALL LANES SHALL BE KEPT OPEN FOR THE REMAINING PART OF EVERYDAY. DAILY LANE CLOSURES ON 63rd STREET REQUIRE DUPAGE COUNTY APPROVAL. DAILY LANE CLOSURES ON OGDEN AVENUE REQUIRE IDOT APPROVAL.
- TRAFFIC CONTROL SHALL CONFORM TO IDOT'S HIGHWAY STANDARDS AND THE "MANUAL ON UNIFORM TRAFFIC CONTROL DEVICES FOR STREETS AND HIGHWAYS" AT ALL TIMES DURING CONSTRUCTION. TRAFFIC CONTROL SHALL INCLUDE ADVANCE WARNING LANE CLOSURE SIGNAGE, AN ARROW BOARD AND TYPE I BARRICADES WITH SANDBAGS.
- THE CONTRACTOR SHALL COORDINATE CONSTRUCTION ACTIVITIES WITH UTILITY COMPANIES AND THE VILLAGE OF WESTMONT.

**NOTE:**  
PROVIDE THERMOPLASTIC PAVEMENT MARKING FOR PEDESTRIAN CROSSWALK AND STOP BARS AT THE FOLLOWING INTERSECTIONS:

**63RD STREET & RIDGE ROAD**  
90 L.F. THERMOPLASTIC PAVEMENT MARKING-LINE, 6" WHITE  
20 L.F. THERMOPLASTIC PAVEMENT MARKING-LINE, 24" WHITE

**OGDEN AVENUE & WASHINGTON STREET**  
92 L.F. THERMOPLASTIC PAVEMENT MARKING-LINE, 6" WHITE  
15 L.F. THERMOPLASTIC PAVEMENT MARKING-LINE, 24" WHITE

**OGDEN AVENUE & ADAMS STREET**  
75 L.F. THERMOPLASTIC PAVEMENT MARKING-LINE, 6" WHITE  
16 L.F. THERMOPLASTIC PAVEMENT MARKING-LINE, 24" WHITE

**EARTHWORK SCHEDULE**

LOCATION	REMOVAL AND DISPOSAL OF UNSUITABLE MATERIAL (CU. YD.)	TOPSOIL FURNISH AND PLACE, 4" (SQ. YD.)
<b>63 RD STREET</b> STA 0+00 TO VIRGINIA DRIVE (STA 6+80)	85	555
RIDGE ROAD TO RICHMOND AVENUE (STA. 0+00 TO STA. 13+01)	205	1,580
<b>RICHMOND AVENUE</b> 63RD STREET TO END (STA. 0+00 TO STA. 19+35)	245	635
<b>OGDEN AVENUE</b> STA. 0+00 TO 1+00	10	4
STA. 12+40 TO STA. 14+17	17	21
STA. 16+14 TO STA. 18+30	13	45
<b>CHICAGO AVENUE</b> VILLAGE LIMITS TO GRANT STREET (STA. 0+00 TO STA. 19+29)	225	1790
<b>CUMNOR ROAD</b> 61ST STREET TO 59TH STREET (STA. 0+00 TO STA. 13+08)	180	725
<b>TOTAL</b>	<b>980</b>	<b>5355</b>

\* TOPSOIL REMOVAL DEPTH ESTIMATED AT 8"



date 11-11-05  
designed M. KUNTZ  
detailed J. HOLZINGER  
checked A. BRYANT



VILLAGE OF WESTMONT  
LEGEND, GENERAL NOTES,  
EARTHWORK SUMMARY  
AND SUMMARY OF QUANTITIES

project 39606  
drawing rev.

F.A.P. RTE.	SECTION	COUNTY	TOTAL SHEETS	SHEET NO.
-	06-00096-00-SW	DU PAGE	16	3
FEDERAL RD. DIST. NO.	ILLINOIS		FEDERAL AID PROJECT	
CONTRACT: 83851				

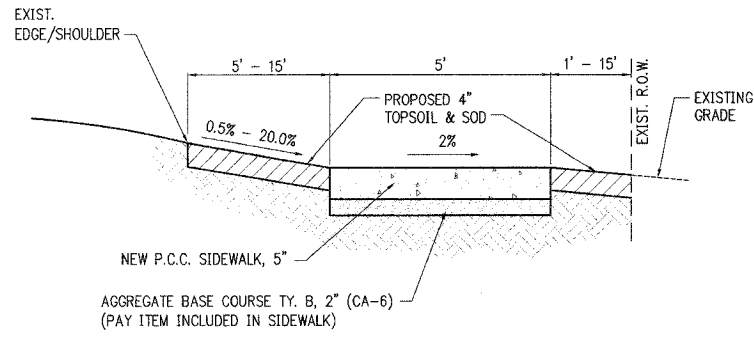

**EXISTING & PROPOSED TYPICAL SECTION**

**63rd STREET**  
 STA. 0+00 TO STA. 6+80  
 (SHEET 4 OF 15)  
 STA. 2+75 TO STA. 5+81  
 STA. 10+85 TO STA. 13+01  
 (SHEET 5 OF 15)

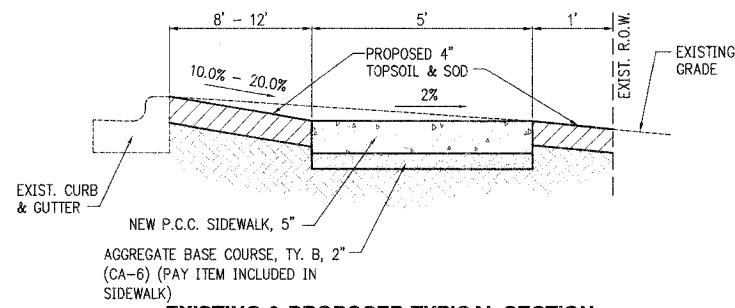

**EXISTING & PROPOSED TYPICAL SECTION**

**63rd STREET**  
 STA. 0+00 TO STA. 2+75  
 (SHEET 5 OF 15)

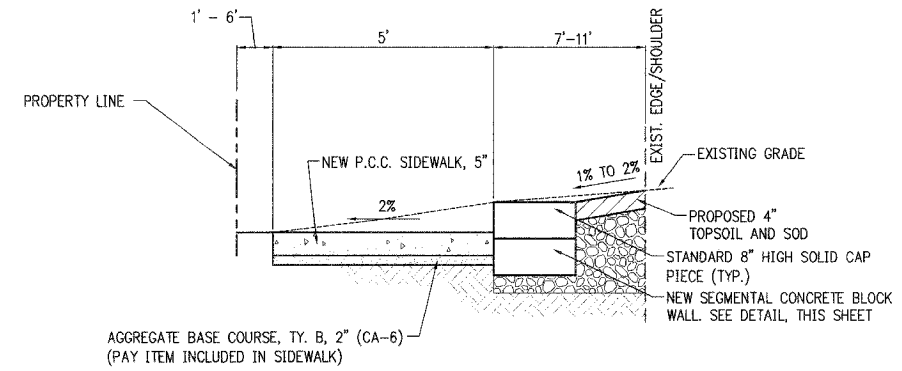

**EXISTING & PROPOSED TYPICAL SECTION**

**63rd STREET**  
 STA. 5+81 TO STA. 6+51  
 (SHEET 5 OF 15)

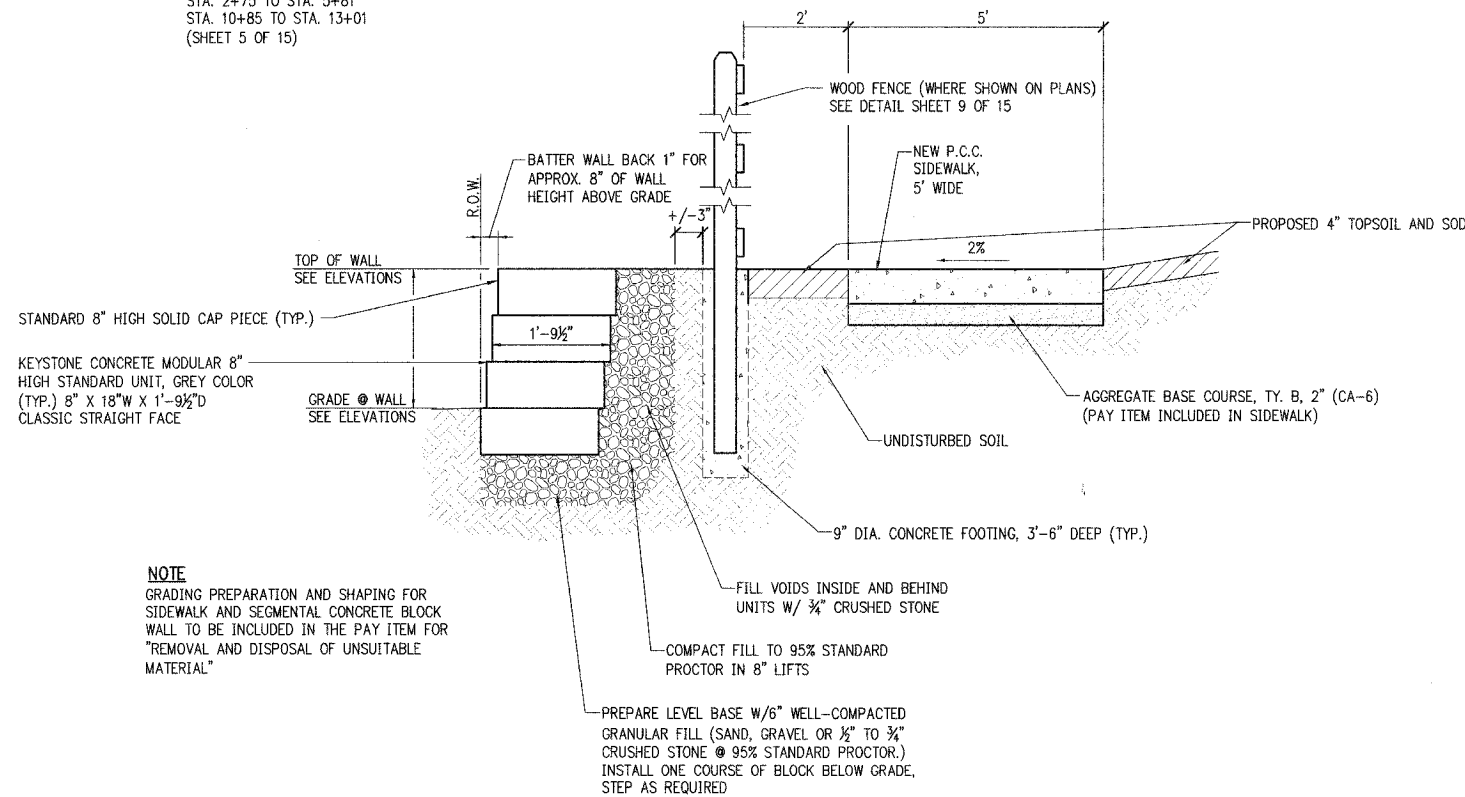

**SEGMENTAL CONCRETE BLOCK WALL TYPICAL SECTION**

**63rd STREET**  
 STA. 6+47 TO STA. 10+85  
 (SHEET 5 OF 15)

**NOTE**  
 GRADING PREPARATION AND SHAPING FOR SIDEWALK AND SEGMENTAL CONCRETE BLOCK WALL TO BE INCLUDED IN THE PAY ITEM FOR "REMOVAL AND DISPOSAL OF UNSUITABLE MATERIAL"

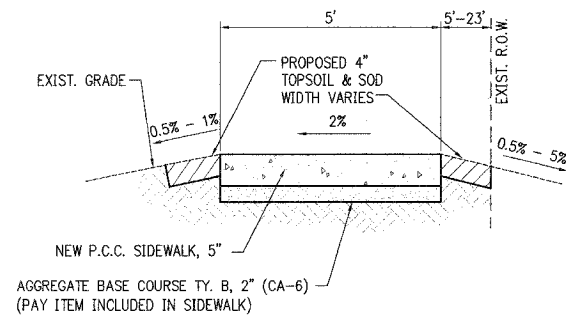

**EXISTING & PROPOSED TYPICAL SECTION**

**RICHMOND AVENUE**  
 STA. STA. 14+50 TO STA. 19+35  
 (SHEET 7 OF 15)

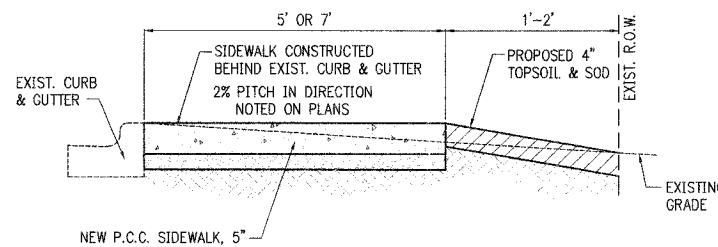

**EXISTING & PROPOSED TYPICAL SECTION**

**OGDEN AVENUE**  
 STA. 0+00 TO STA. 1+00  
 STA. 12+40 TO STA. 14+17  
 (SHEET 8 OF 15)

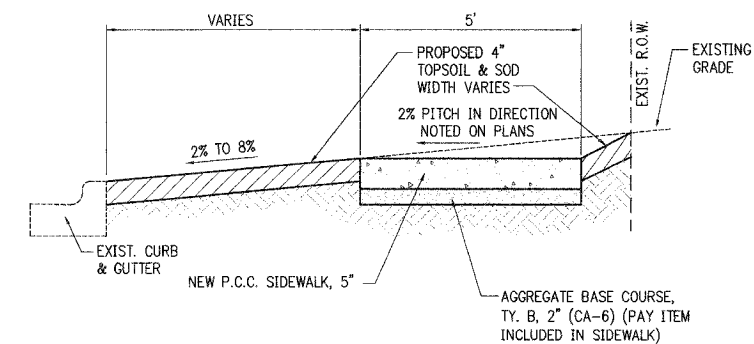

**EXISTING & PROPOSED TYPICAL SECTION**

**OGDEN AVENUE**  
 STA. 16+14 TO STA. 18+30  
 (SHEET 8 OF 15)

Scale For Microfilming  
 Inches  
 Millimeters

COPYRIGHT © 2005 BURNS AND MCDONNELL ENGINEERING COMPANY, INC.



date	11-11-05	detailed	J. HOLZINGER
designed	M. KUNTZ	checked	A. BRYANT



VILLAGE OF WESTMONT	
2006 CMAQ SIDEWALK PROJECT TYPICAL SECTIONS	
project	contract
39606	
drawing	rev.
sheet 3	of 16 sheets
file I:\WESTMONT\39606-2006 SW...CAD\BEDTYP_SECT	

F.A.P. RTE.	SECTION	COUNTY	TOTAL SHEETS	SHEET NO.
06-00096-00-SW	DU PAGE	ILLINOIS	16	4
FEDERAL RD. DIST. NO.		ILLINOIS FEDERAL AID PROJECT		
CONTRACT: 83851				

63RD

STREET

CONNAMARA COURT

EXISTING SIDEWALK

Scale For Microfilming  
Millimeters  
Inches

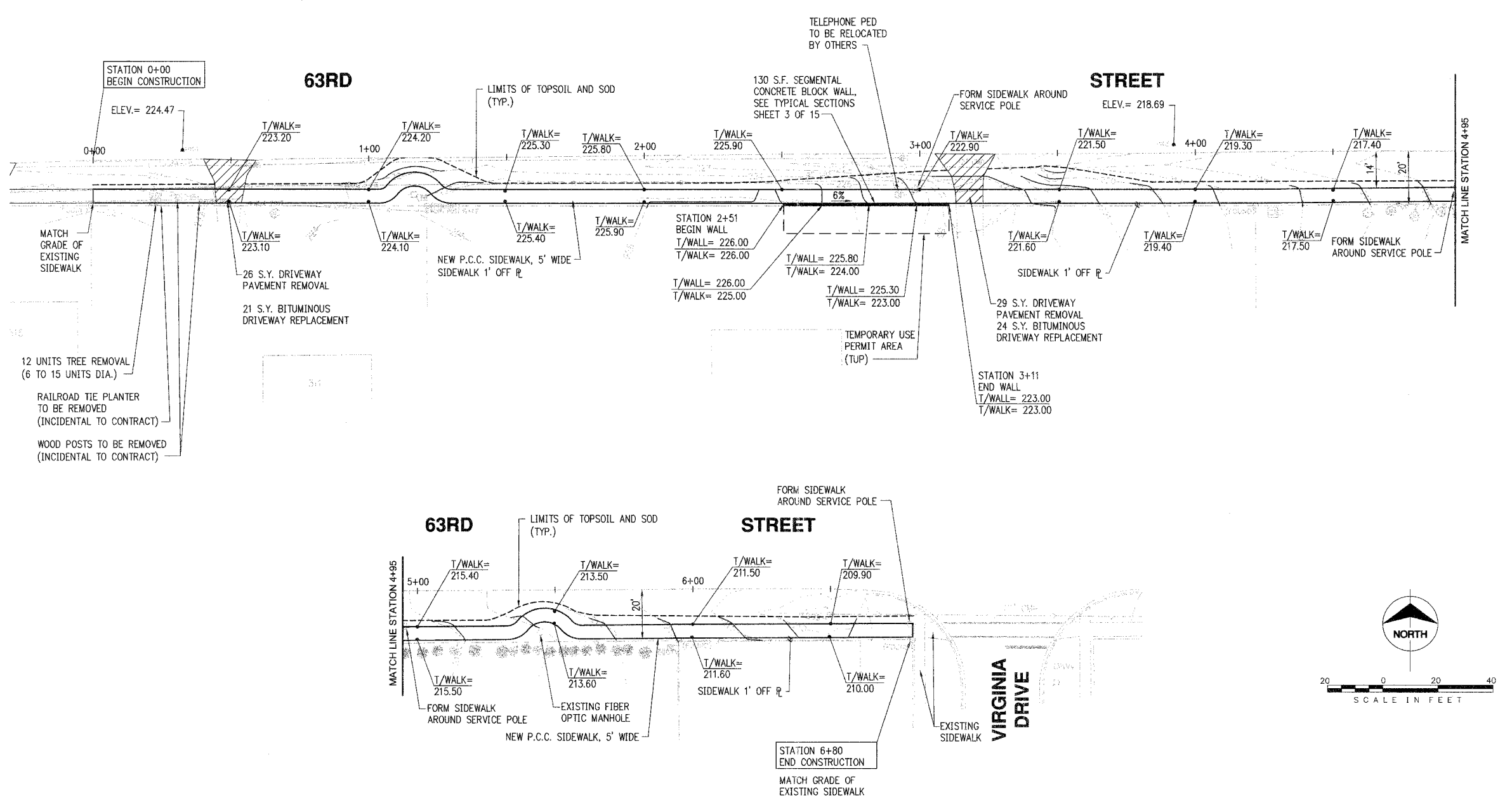

no.	date	by	ckd	description



date	11-11-05	detailed	G. ALVAREZ
designed	M. KUNTZ	checked	A. BRYANT

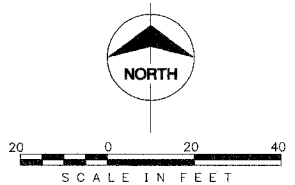

VILLAGE OF WESTMONT 2006 CMAQ SIDEWALK PROJECT 63RD STREET PLAN STA. 0+00 TO VIRGINIA DRIVE	
project	contract
39606	
drawing	rev.
sheet 4	of 16 sheets
file: \\WESTMONT\39606-2006 SW DESIGN\CAD\RD\39606CP001	

F.A.P. R.T.E.	SECTION	COUNTY	TOTAL SHEETS	SHEET NO.
	06-00096-00-SW	DU PAGE	16	5
FEDERAL RD. DIST. NO.	ILLINOIS FEDERAL AID PROJECT			
CONTRACT: 83851				

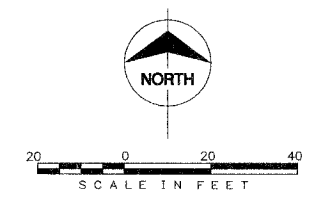
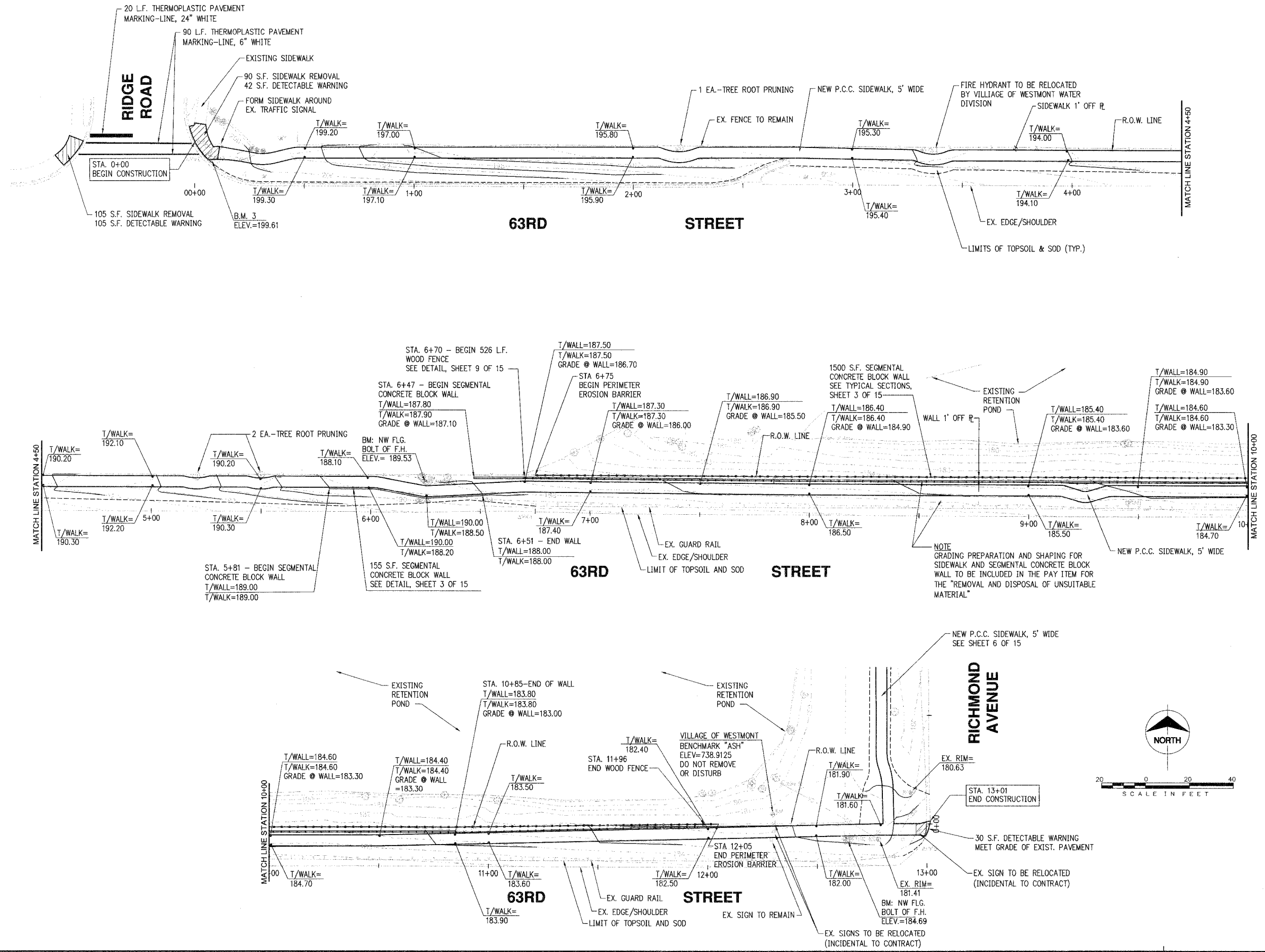

no.	date	by	ckd	description

<b>Burns &amp; McDonnell</b> SINCE 1878		
date	detailed	
11-11-05	J. HOLZINGER	
designed	checked	
M. KUNTZ	A. BRYANT	
VILLAGE OF WESTMONT 2006 CMAQ SIDEWALK PROJECT 63RD STREET PLAN RIDGE ROAD TO RICHMOND AVE.		
project	contract	
39606		
drawing	rev.	
sheet	of	sheets
5	16	
file I:\WESTMONT\39606-2006 SW DESIGN\CAD\RD\39606PCP04		

COPYRIGHT © 2005 BURNS AND MCDONNELL ENGINEERING COMPANY, INC.

F.A.P. RTE.	SECTION	COUNTY	TOTAL SHEETS	SHEET NO.
	06-00096-00-SW	DU PAGE	16	6
FEDERAL RD. DIST. NO.	ILLINOIS	FEDERAL AID PROJECT		
CONTRACT: 83851				

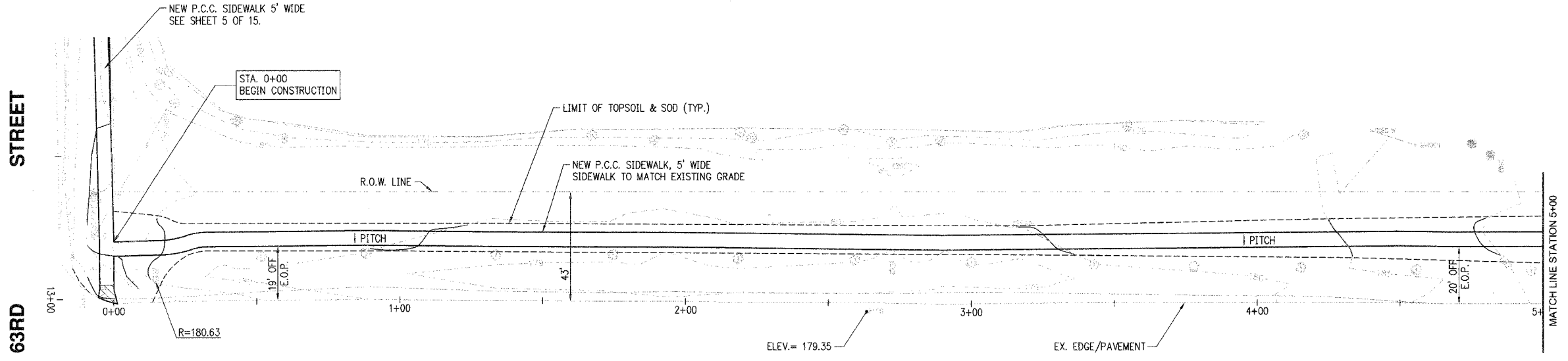

**RICHMOND**

**AVENUE**

Scale For Microfilming

Inches

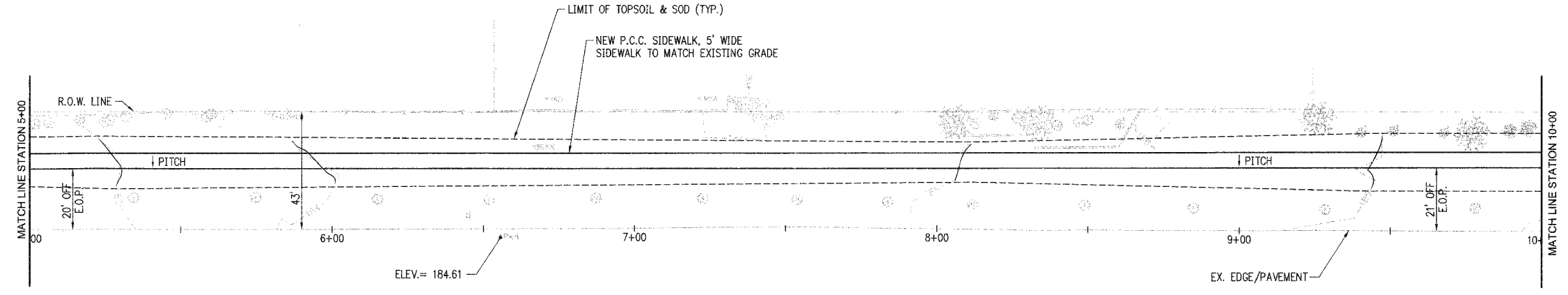

**RICHMOND**

**AVENUE**

B.M. NE FLNG BOLT ON FIRE HYDRANT  
ELEV.= 185.42

no.	date	by	ckd	description



date	11-11-05	detailed	G. ALVAREZ
designed	M. KUNTZ	checked	A. BRYANT



VILLAGE OF WESTMONT 2006 CMAQ SIDEWALK PROJECT RICHMOND AVENUE PLAN 63RD STREET TO STA. 10+00	
project	contract
39606	
drawing	rev.
sheet 6	of 16 sheets
file: \\WESTMONT\39606-2006 SW DESIGN\CAD\BID\39606CP005	

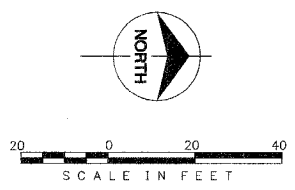

COPYRIGHT © 2006 BURNS AND MCDONNELL ENGINEERING COMPANY, INC.

F.A.P. RTE.	SECTION	COUNTY	TOTAL SHEETS	SHEET NO.
06-00096-00-SW	DU PAGE	ILLINOIS	16	7
FEDERAL RD. DIST. NO. ILLINOIS FEDERAL AID PROJECT				
CONTRACT: 83851				

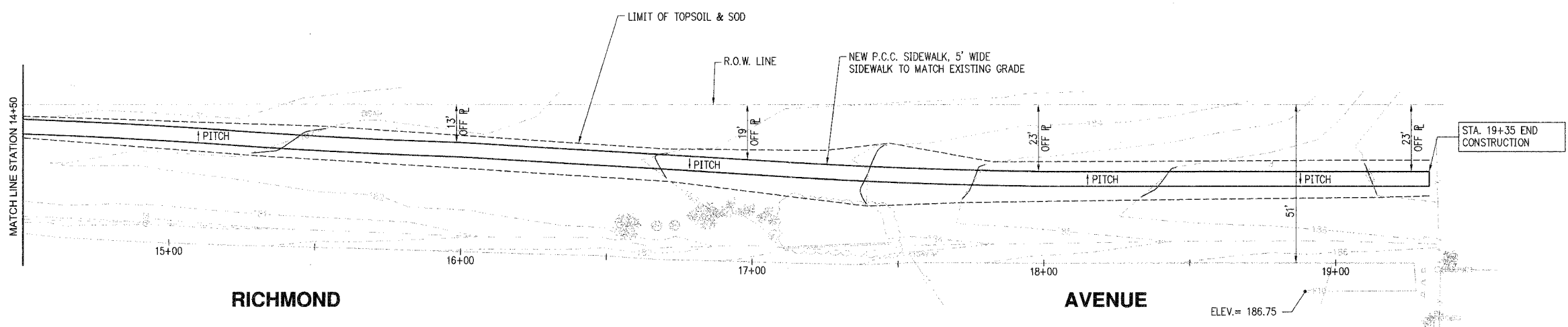
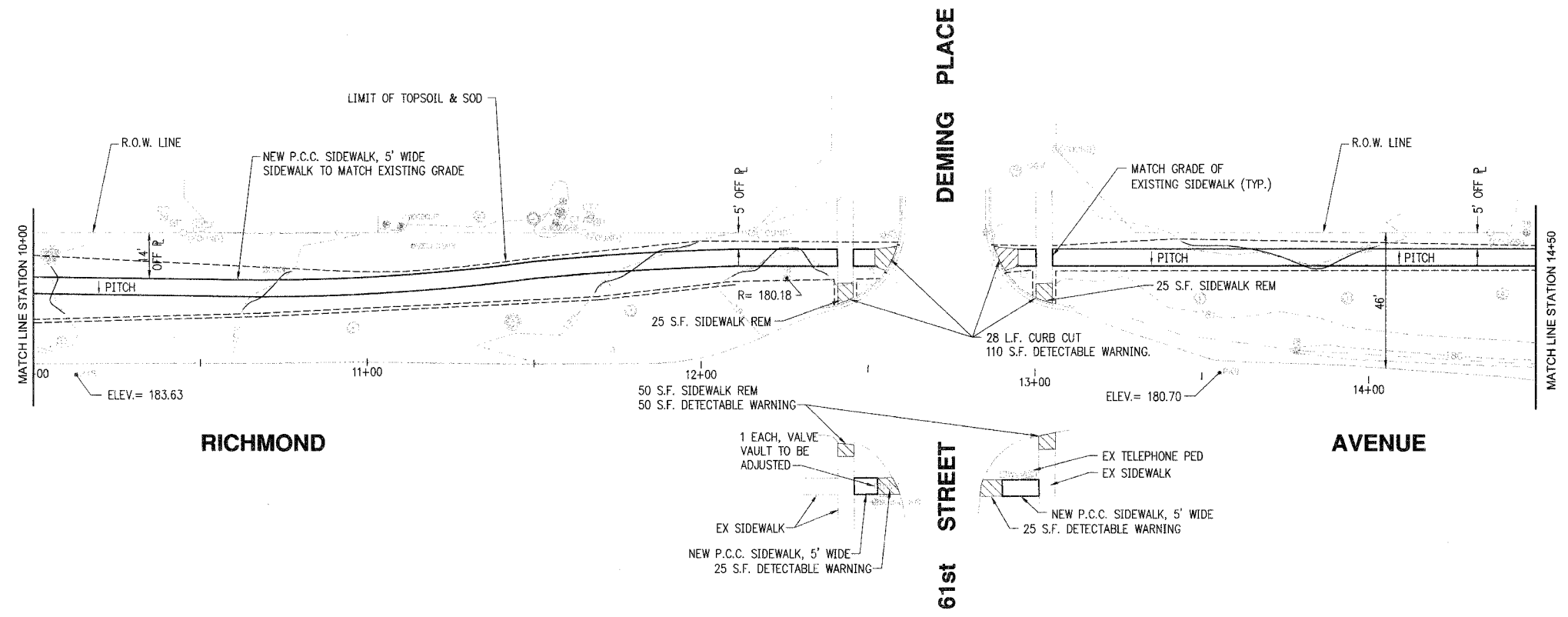

Scale For Microfitting

Inches

COPYRIGHT © 2006 BURNS AND MCDONNELL ENGINEERING COMPANY, INC.

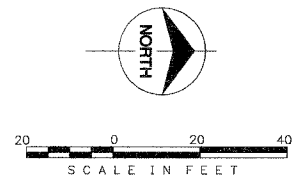

no.	date	by	ckd	description



date	11-11-05	detailed	G. ALVAREZ
designed	M. KUNTZ	checked	A. BRYANT



VILLAGE OF WESTMONT  
2006 CMAQ SIDEWALK PROJECT  
RICHMOND AVENUE PLAN  
STA. 10+00 TO STA. 19+35

project	39606	contract	
drawing		rev.	

sheet 7 of 16 sheets  
file: WESTMONT\39606-2006 SW DESIGN\CAD\BID\39606CP006

F.A.P. RTE.	SECTION	COUNTY	TOTAL SHEETS	SHEET NO.
	06-00096-00-SW	DU PAGE	16	8
FEDERAL RD. DIST. NO.	ILLINOIS FEDERAL AID PROJECT			
CONTRACT: 83951				

**WILLIAMS STREET**

**PARK STREET**

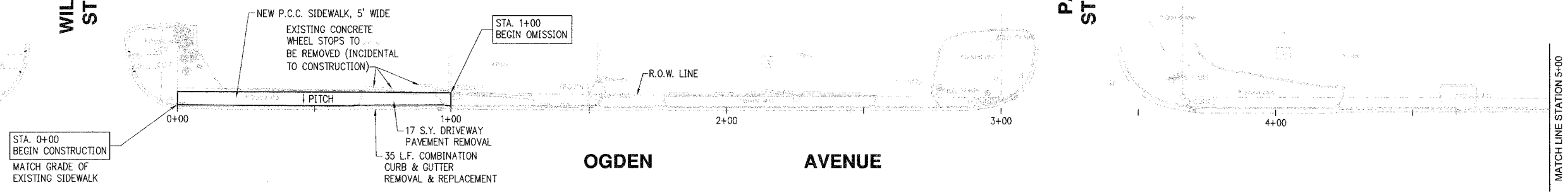

MATCH LINE STATION 5+00

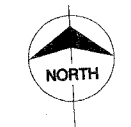

**OGDEN AVENUE**

**LIBERTY BLVD.**

**OGDEN AVENUE**

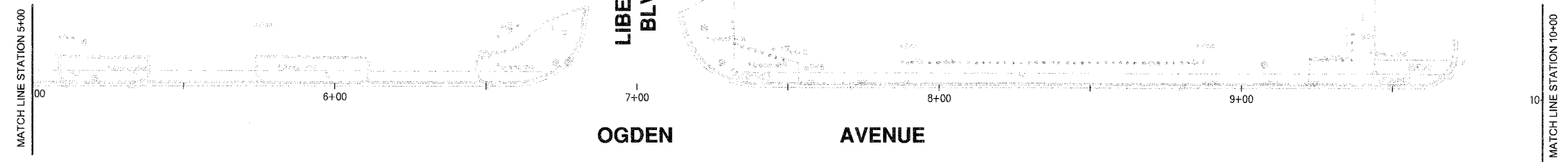

**WASHINGTON STREET**

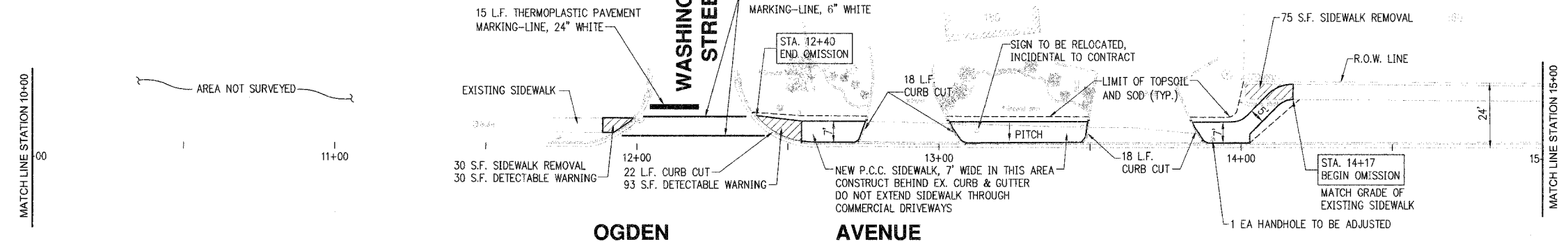

**OGDEN AVENUE**

**ADAMS STREET**

**GRANT STREET**

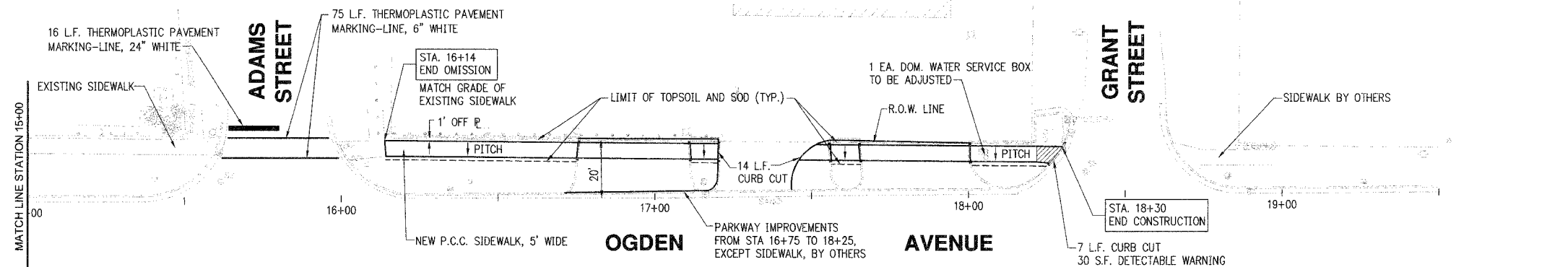

**OGDEN AVENUE**

no.	date	by	ckd	description
date	11-11-05	detailed	J. HOLZINGER	
designed	M. KUNTZ	checked	A. BRYANT	
VILLAGE OF WESTMONT 2006 CMAQ SIDEWALK PROJECT OGDEN AVENUE PLAN WILLIAMS STREET TO GRANT STREET				
project	39606	contract		
drawing		rev.		
sheet	8	of	16	sheets
file L:\WESTMONT\39606-2006 SW DESIGN\CAD\39606CP003				

Copyright © 2005 Burns and McDonnell Engineering Company, Inc.  
 Scale For Microfilming  
 Inches  
 Millimeters





F.A.P. RTE.	SECTION	COUNTY	TOTAL SHEETS	SHEET NO.
06-00086-00-SW	DU PAGE	ILLINOIS	16	10
FEDERAL RD. DIST. NO.		FEDERAL AID PROJECT		
CONTRACT: 83851				

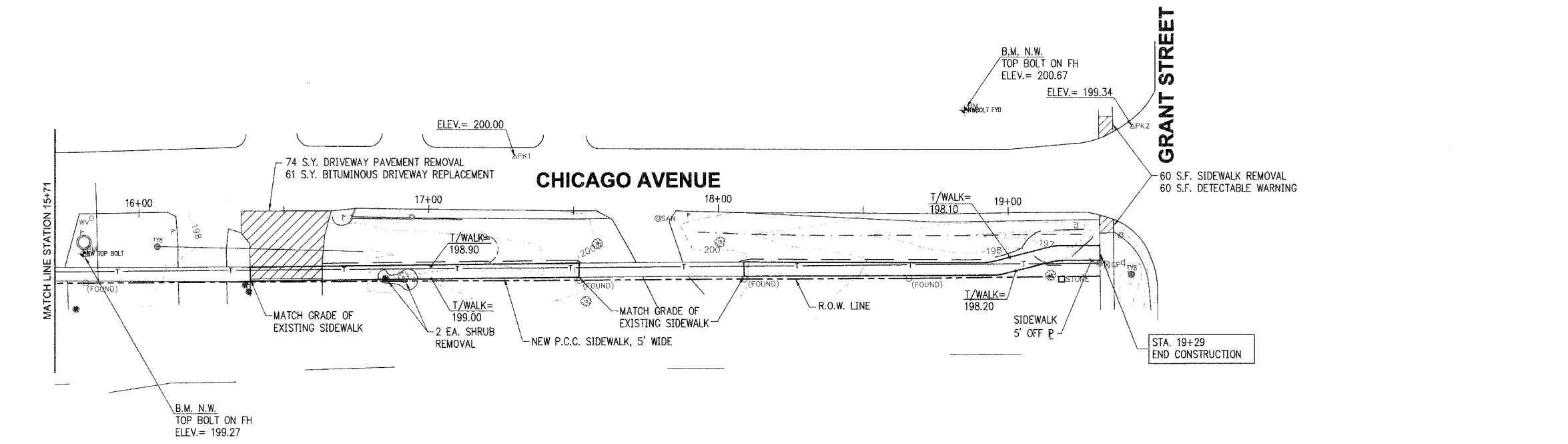
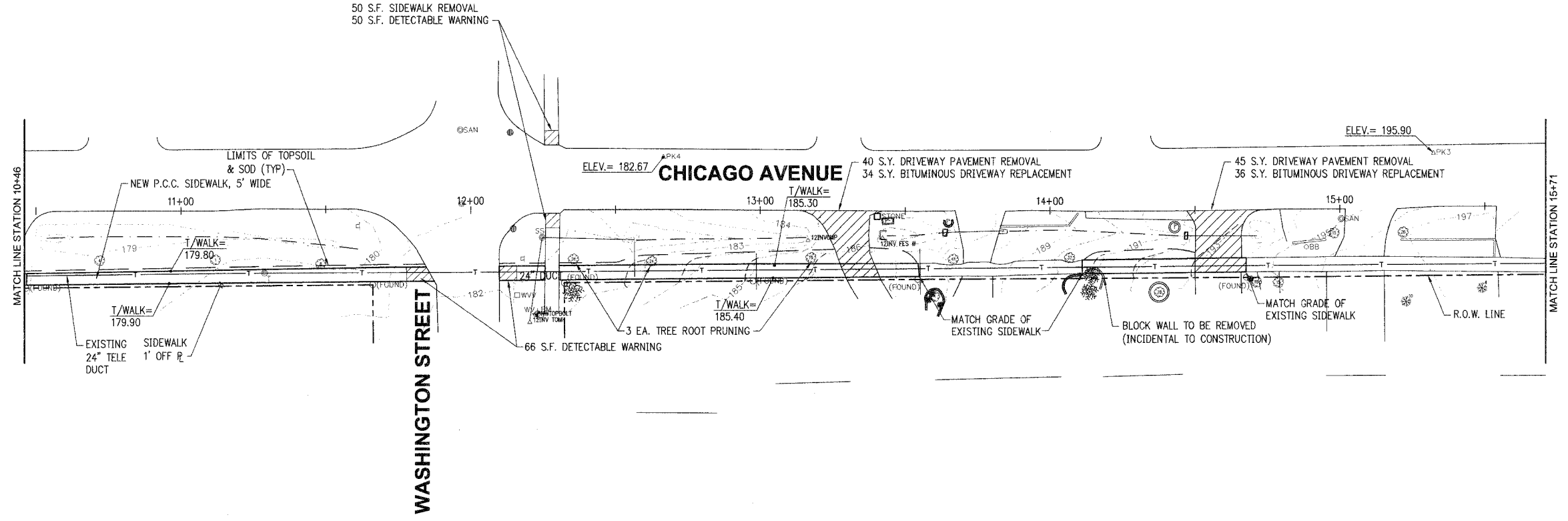

Scale For Microfilming  
Millimeters

Scale For Microfilming  
Inches

COPYRIGHT © 2006 BURNS AND MCDONNELL ENGINEERING COMPANY, INC.

no.	date	by	ckd	description



date	11-11-05	detailed	G. ALVAREZ
designed	M. KUNTZ	checked	A. BRYANT



VILLAGE OF WESTMONT  
2006 CMAQ SIDEWALK PROJECT  
CHICAGO AVENUE PLAN  
STA. 10+46 TO GRANT STREET

project	39606	contract	
drawing		rev.	

sheet 10 of 16 sheets  
file I:\WESTMONT\39606-2006 SW DESIGN\CAD\BID\39606C06

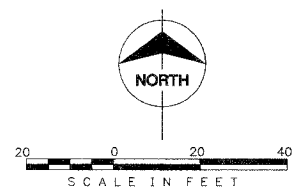

F.A.P. R.T.E.	SECTION	COUNTY	TOTAL SHEETS	SHEET NO.
	06-00096-00-SW	DU PAGE	16	11
FEDERAL RD. DIST. NO.	ILLINOIS FEDERAL AID PROJECT			
CONTRACT: 83851				

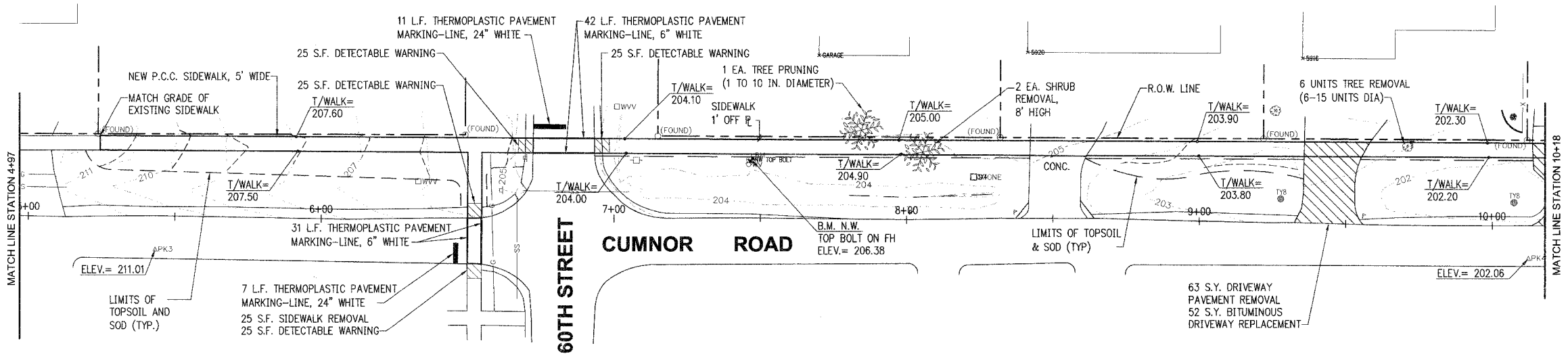
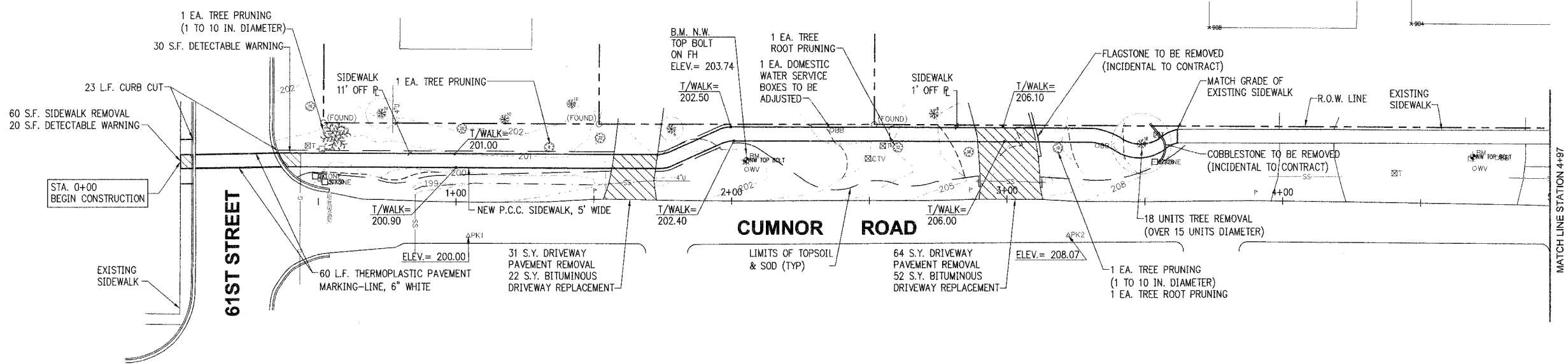

Scale For Micromapping  
Millimeters

Scale For Micromapping  
Inches

COPYRIGHT © 2005 BURNS AND MCDONNELL ENGINEERING COMPANY, INC.

no.	date	by	ckd	description
-----	------	----	-----	-------------





date	11-11-05	detailed	G. ALVAREZ
designed	M. KUNTZ	checked	A. BRYANT

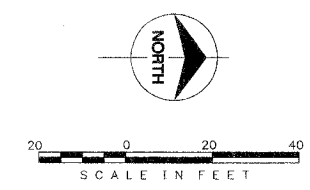

VILLAGE OF WESTMONT	
2006 CMAQ SIDEWALK PROJECT	
CUMNOR ROAD PLAN	
61ST STREET TO 10+18	
project	39606
contract	
drawing	rev.
sheet	11 of 16 sheets
file I:\WESTMONT\39606-2006 SW DESIGN\CAD\BID\39606C009	

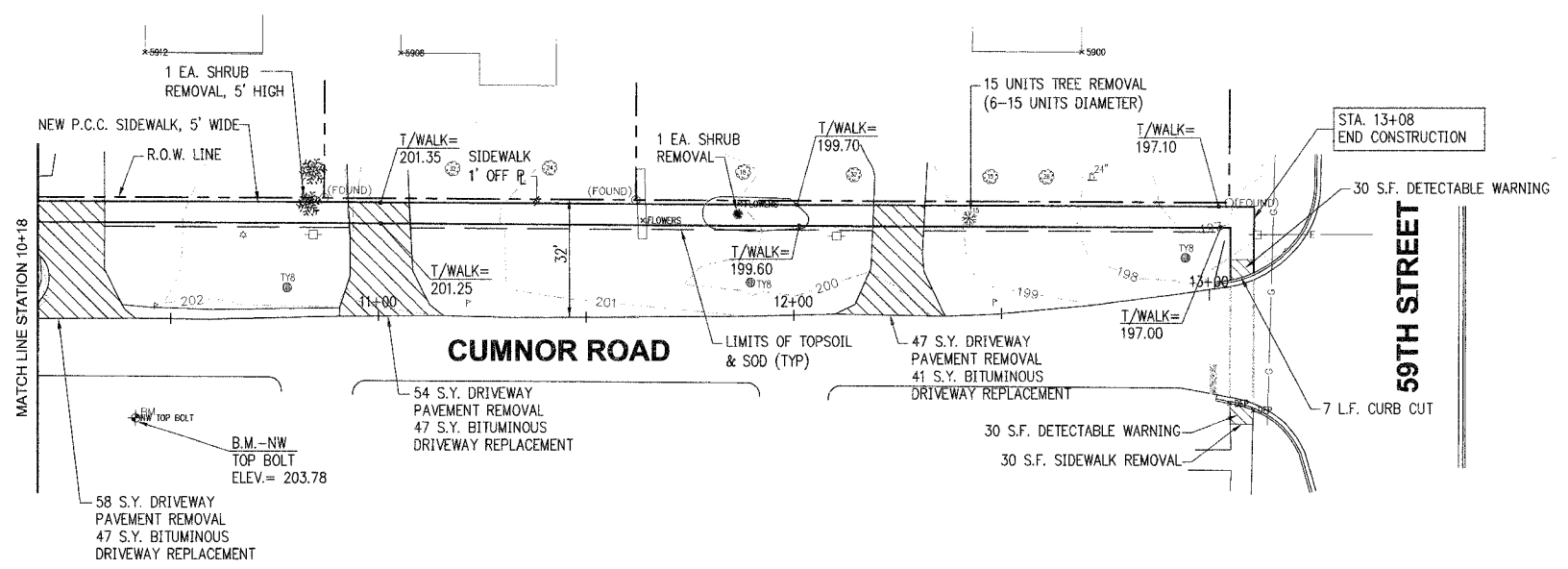
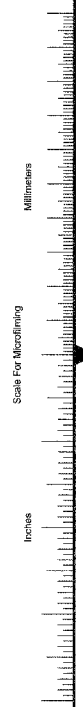

F.A.P. RTE.	SECTION	COUNTY	TOTAL SHEETS	SHEET NO.
	06-00096-00-SW	DU PAGE	16	12
FEDERAL RD. DIST. NO.		ILLINOIS FEDERAL AID PROJECT		
CONTRACT: 83851				



no.	date	by	ckd	description
-----	------	----	-----	-------------





date	11-11-05	detailed	G. ALVAREZ
designed	M. KUNTZ	checked	A. BRYANT

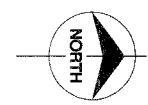

VILLAGE OF WESTMONT 2006 CMAQ SIDEWALK PROJECT CUMNOR ROAD PLAN STA. 10+18 TO 59TH STREET	
project	39606
contract	
drawing	
rev.	
sheet	12 of 16 sheets
file I:\WESTMONT\39606-2006 SW DESIGN\CAD\BID\39606C010	

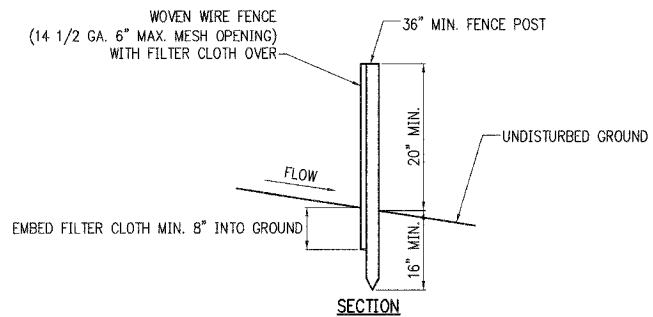
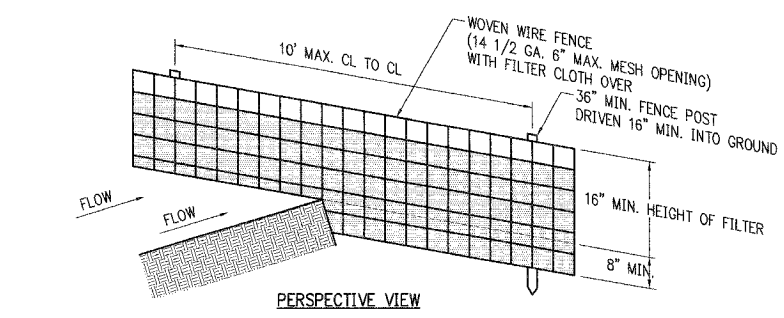

F.A.P. R.T.E.	SECTION	COUNTY	TOTAL SHEETS	SHEET NO.
	06-00096-00-SW	DU PAGE	16	13
FEDERAL RD. DIST. NO.	ILLINOIS	FEDERAL AID PROJECT		
CONTRACT: 83851				



**SILT FENCE**  
N.T.S.

**CONSTRUCTION NOTES FOR FABRICATED SILT FENCE**

1. WOVEN WIRE FENCE TO BE FASTENED SECURELY TO FENCE POSTS WITH WIRE TIES OR STAPLES.
  2. FILTER CLOTH TO BE FASTENED SECURELY TO WOVEN WIRE FENCE WITH TIES SPACED EVERY 24" AT TOP AND MID SECTION.
  3. WHEN TWO SECTIONS OF FILTER CLOTH ADJOIN EACH OTHER THEY SHALL BE OVER LAPPED BY 6" AND FOLDED.
  4. MAINTENANCE SHALL BE PERFORMED AS NEEDED AND MATERIAL REMOVED WHEN "BULGES" DEVELOP IN THE SILT FENCE.
- POSTS: STEEL EITHER "I" OR "U" TYPE OR 2" HARDWOOD  
 FENCE: WOVEN WIRE 14 1/2 GA. 6" MAX. MESH OPENING  
 FILTER CLOTH: FILTER X, MIRAFI 100X OR STABLINKA T140N  
 PREFABRICATED UNIT: GOEFAB, ENVIROFENCE

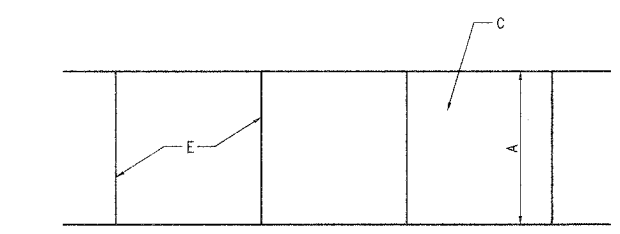

**PLAN**

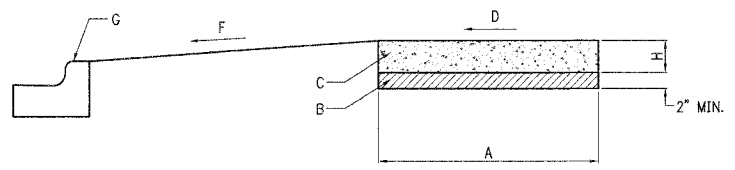

**PROFILE**

**SIDEWALK DETAIL**

**CONSTRUCTION NOTES**

- A. 5' NORMAL WIDTH OR AS INDICATED ON PLANS
- B. AGGREGATE BASE COURSE, TYPE B, 2"
- C. P.C.C. SIDEWALK
- D. SLOPE 1/4" PER FOOT TO STREET SIDE, OR AS NOTED ON PLAN
- E. JOINTS, SEE NOTES 3 AND 4
- F. SLOPE 2% TO 8% TOWARDS STREET
- G. CURB AND GUTTER
- H. CONCRETE THICKNESS, SEE NOTE 1

**GENERAL NOTES**

1. STANDARD THICKNESS OF CONCRETE SHALL BE A MINIMUM OF 5".
2. WHERE WOODEN FORMS ARE USED, 2x4'S ARE NOT ALLOWED. ONLY 2x6'S SHALL BE USED.
3. PREFORMED 3/4" EXPANSION JOINTS SHALL BE CONSTRUCTED AT MAX. SPACING OF 40'.
4. FORMED OR SAW-CUT CONTRACTION JOINTS SHALL BE SPACED GENERALLY 5' APART, BUT NO LESS THAN 4' AND NO MORE THAN 6'.
5. 1/2" EXPANSION JOINTS SHALL BE INSTALLED WHERE SIDEWALK ABUTS BUILDINGS, TRAFFIC SIGNAL FOUNDATIONS, SERVICE POLES, AND OTHER IMMOVABLE STRUCTURES.
6. CONCRETE TO BE MINIMUM 6-BAG MIX.

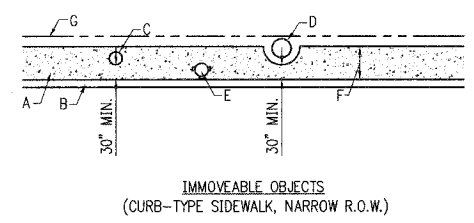

**IMMOVABLE OBJECTS**  
(CURB-TYPE SIDEWALK, NARROW R.O.W.)

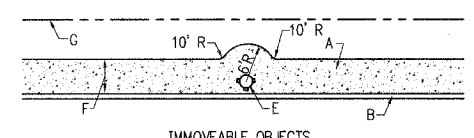

**IMMOVABLE OBJECTS**  
(CURB-TYPE SIDEWALK, WIDE R.O.W.)

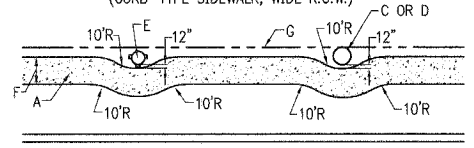

**IMMOVABLE OBJECTS**  
(SIDEWALK WITH PARKWAY)

**CONSTRUCTION NOTE:**

- A. SIDEWALK
- B. CURB
- C. SERVICE POLE, SEE NOTES 1 AND 3.
- D. TREE TRUNK, SEE NOTE 1
- E. FIRE HYDRANT, SEE NOTES 1, 2, AND 3.
- F. SIDEWALK WIDTH
- G. RIGHT-OF-WAY (R.O.W.)

**GENERAL NOTES:**

1. A FIRE HYDRANT, SERV. POLE OR TREE TRUNK SHALL BE CONSIDERED IMMOVABLE ONLY WHEN DIRECTED BY THE VILLAGE ENGINEER.
2. THE VILLAGE OF WESTMONT WATER DEPT. SHALL BE CONTACTED AS SOON AS POSSIBLE WHENEVER A FIRE HYDRANT IS FOUND TO BE IN THE PATH OF A NEW SIDEWALK, SO THAT THE FIRE HYDRANT CAN BE RELOCATED, IF POSSIBLE.
3. WHEN A SERVICE POLE OR FIRE HYDRANT IS LOCATED WITHIN THE SIDEWALK AREA, AND IS CONSIDERED IMMOVABLE, A 1/2" EXPANSION JOINT SHALL BE INSTALLED ENCIRCLING THE OBJECT.

**SIDEWALK OBSTRUCTIONS**

N.T.S.

**CONSTRUCTION NOTES:**

- A. STAMPED CONCRETE PAVEMENT OR CONCRETE BRICK PAVERS.
- B. FOR CONCRETE-ROUND FRAME SHALL BE EQUIVALENT TO TYLER 6895 VALVE BOX. FOR BRICK PAVERS-SQUARE FRAME SHALL BE EQUIVALENT TO NEENAH B-1978-1 INSPECTION FRAME.
- C. COMPACTED AGGREGATE BASE, MIN. 2".
- D. SERVICE BOX LID WITH BRASS PENTAGON HEAD PLUG, TOP TO BE MARKED "WATER".
- E. SERVICE BOX EXTENSION.
- F. SERVICE BOX SET 4"-6" BELOW FINISHED GRADE.
- G. SUBGRADE.

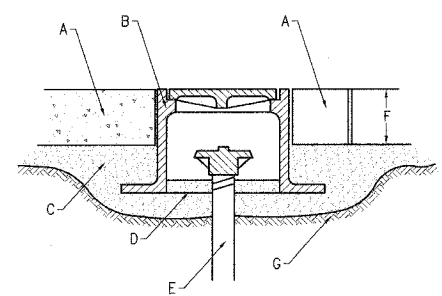

**SERVICE BOX INSTALLATION**  
**IN PAVEMENT AREAS**  
N.T.S.

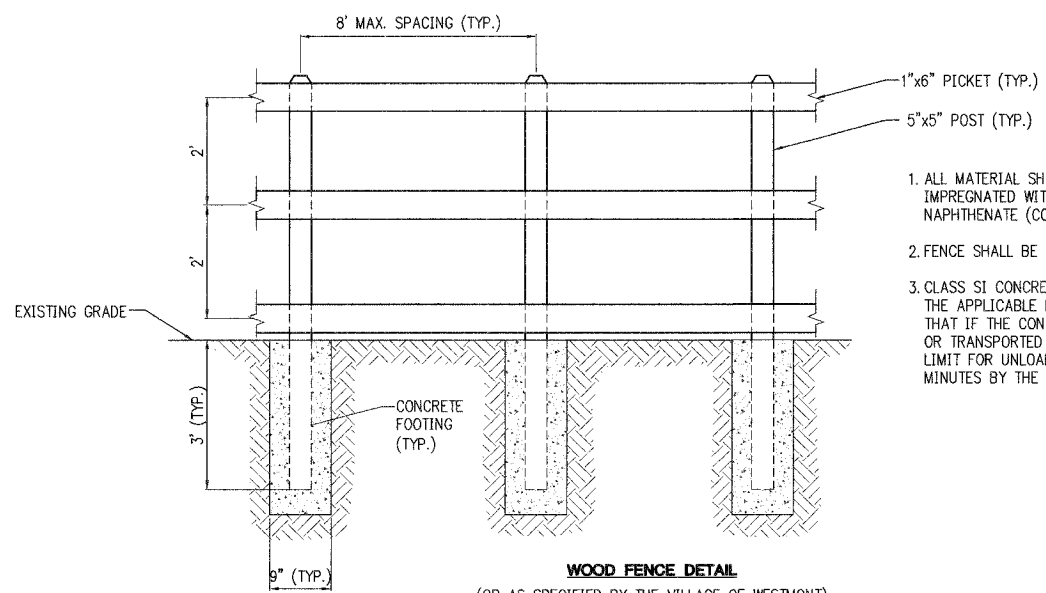

**WOOD FENCE DETAIL**

(OR AS SPECIFIED BY THE VILLAGE OF WESTMONT)  
NOT TO SCALE

1. ALL MATERIAL SHALL BE SOUTHERN YELLOW PINE IMPREGNATED WITH THE PRESERVATIVE, COPPER NAPHTHENATE (COPPERWOOD OR APPROVED EQUAL).
2. FENCE SHALL BE ASSEMBLED BY FACE NAILING.
3. CLASS SI CONCRETE SHALL BE USED CONFORMING TO THE APPLICABLE PORTIONS OF SECTION 1020, EXCEPT THAT IF THE CONCRETE IS MIXED IN TRANSIT MIXERS OR TRANSPORTED IN AGITATOR TRUCKS, THE TIME LIMIT FOR UNLOADING IT MAY BE EXTENDED TO 120 MINUTES BY THE ENGINEER.



date 11-11-05 detailed L.SAUCEDO  
 designed M. KUNTZ checked



VILLAGE OF WESTMONT  
 2006 CMAQ SIDEWALK  
 MISCELLANEOUS DETAILS (1 OF 2)  
 project 39606 contract  
 drawing rev.  
 sheet 13 of 16 sheets  
 file 1:WESTMONT\39606-2006 SW DESIGN\CAD\BIDDDETAILS

F.A.P. RTE.	SECTION	COUNTY	TOTAL SHEETS	SHEET NO.
	06-00096-00-SW	DU PAGE	16	14
FEDERAL RD. DIST. NO.	ILLINOIS FEDERAL AID PROJECT			
CONTRACT: 83851				

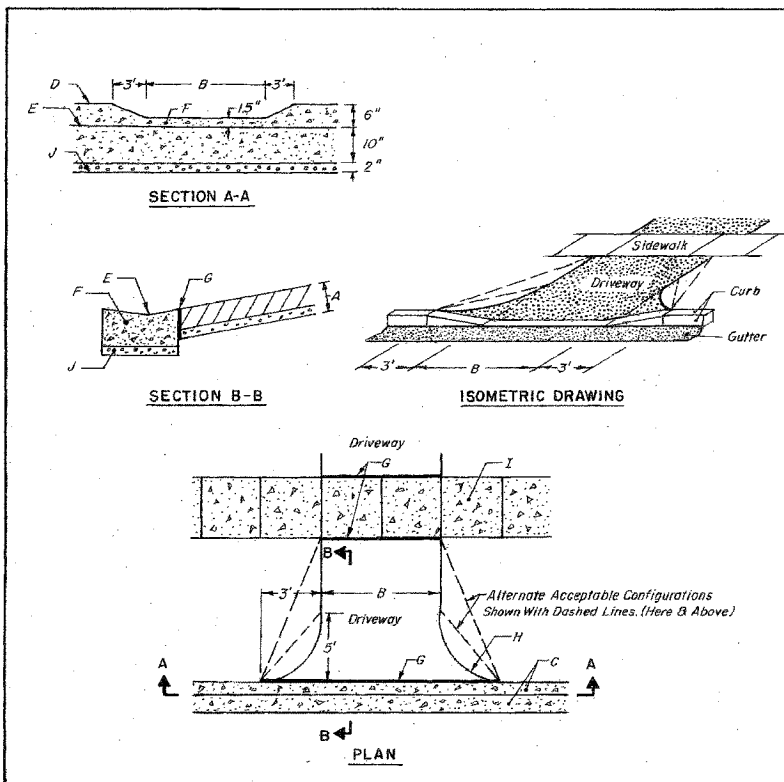

**CONSTRUCTION NOTES**

- For Concrete Driveways, Min. 5" P.C.C. Over a Min. 2" Compacted Aggregate Base. For Asphalt Driveways, Min. 2" Bituminous Concrete Over a Min. 8" Compacted Aggregate Base.
- Min. Width 9' Max. 20'
- Curb & Gutter
- Top of Curb
- Flow Line of Gutter
- Depressed Type Curb & Gutter
- 3/4" Expansion Joint Required For Concrete Driveways Only.
- 5' Radius
- P.C.C. Sidewalk, See Notes 2 & 3.
- Min. 2" Aggregate Base

**GENERAL NOTES**

- For Concrete Driveways Wider Than 14', a Contraction Joint Shall be Located Along The Centerline of The Driveway.
- Sidewalk Shall be a Minimum of 5" Thick.
- A Minimum 6-Bag Mix Concrete Shall be Used For Concrete Driveways, Sidewalks, And Curb and Gutter.

**VILLAGE OF WESTMONT**  
**RESIDENTIAL DRIVEWAY**  
**DETAIL**

ISSUED: March 1988  
 REVISED: August 2002  
 August 2003

DWG. R-7-2

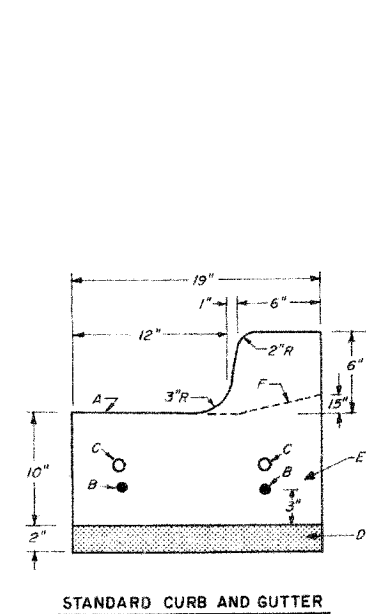

**CONSTRUCTION NOTES**

- Slope 3/4"/ft.
- 2-#4 Bars Continuous, Optional.
- 2 Dowel Bars at Expansion Joints.
- Min. 2" Aggr. Base
- Min. 6-Bag Mix Concrete.
- Depressed Curb Configuration.

**GENERAL NOTES**

- Standard Curb and Gutter Shall be Used For All New Construction. Roll-Type Curb and Gutter is Not Acceptable.
- Preformed Expansion Joints of 3/4" Thickness Shall be Spaced a Maximum of 40' Apart, and at All Radius Points and 4' Either Side of Inlets.
- Formed or Saw-Cut Contraction Joints Shall be Spaced a Maximum of 10' Apart and Filled with a Silicone Sealant.
- Concrete Barrier-Type Curb and Gutter Shall be Provided for All Parking Lots Accommodating Five (5) or More Parking Spaces.

**VILLAGE OF WESTMONT**  
**CURB AND GUTTER DETAIL**

ISSUED: March 1988  
 REVISED: August 2003

DWG. R-6-1

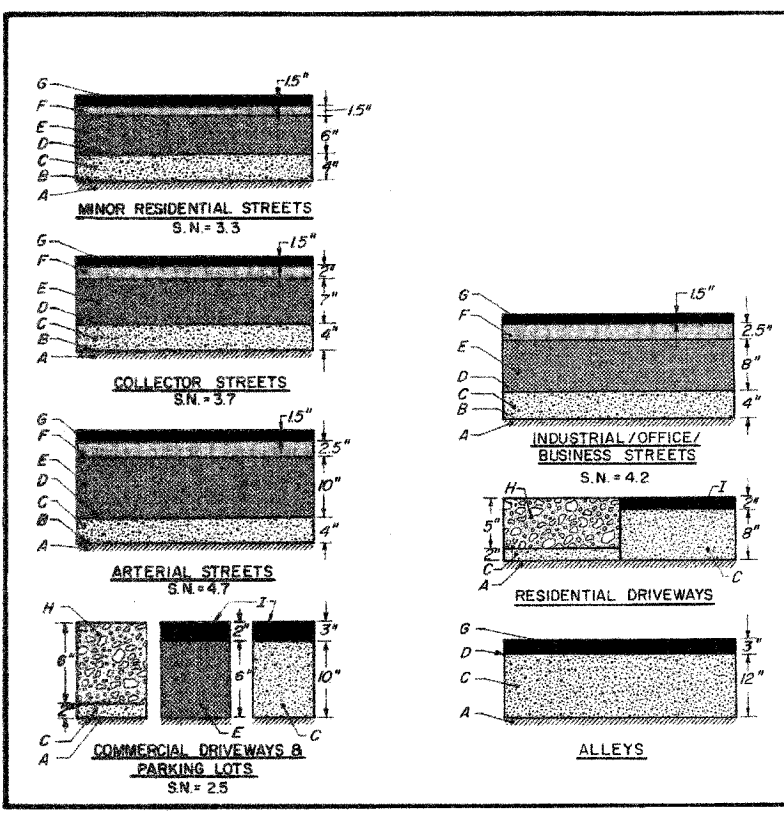

**CONSTRUCTION NOTES**

- Approved Subgrade
- Geotechnic Fabric for Soil Stabilization. See Note 4.
- Aggr. Base Course, Type B, CA-6
- 0.5 Gal./SY Bit. Materials (Prime Coat)
- Bit. Aggregate Mixture (BAM), MS = 1500
- Bit. Conc. Binder Course
- Bit. Conc. Surface Course, Class I
- P.C.C., Min. 6-Bag Mix
- Bit. Conc. Surface Course

**GENERAL NOTES**

- These Are Minimum Standards Only. Structural Design of Streets Shall be Determined Using State Highway Standards, (With These Minimums) Except Where Approved by Village Engineer.
- 2% Crown to be Installed on All Streets.
- 2% Inverted Crown to be Installed in Alleys.
- Geotechnic Fabric Over Subgrade shall be Minimum 4 oz. per Square Yard. Woven or Non-Woven Engineering Fabric, Meeting State Standards.

**VILLAGE OF WESTMONT**  
**MINIMUM PAVEMENT**  
**CROSS - SECTIONS**

ISSUED: March 1988  
 REVISED:

DWG. R-1-0



date 02-22-06 detailed J. HOLZINGER  
 designed M. KUNTZ checked A. BRYANT



VILLAGE OF WESTMONT  
 2006 CMAQ SIDEWALK  
 MISCELLANEOUS DETAILS (2 OF 2)  
 project 39606 contract  
 drawing rev.  
 sheet 14 of 16 sheets  
 file \\WESTMONT\39606-2006 SW DESIGN\CAD\BID\DETAILS\_2

Scale For Microfilming  
 Inches  
 Copyright © 2006 Burns and McDonnell Engineering Company, Inc.

F.A. RTE.	SECTION	COUNTY	TOTAL SHEETS	SHEET NO.
	06-00096-008A	DuPage	16	15
STA.	TO STA.			
FED. ROAD DIST. NO.	ILLINOIS	FED. AID PROJECT		

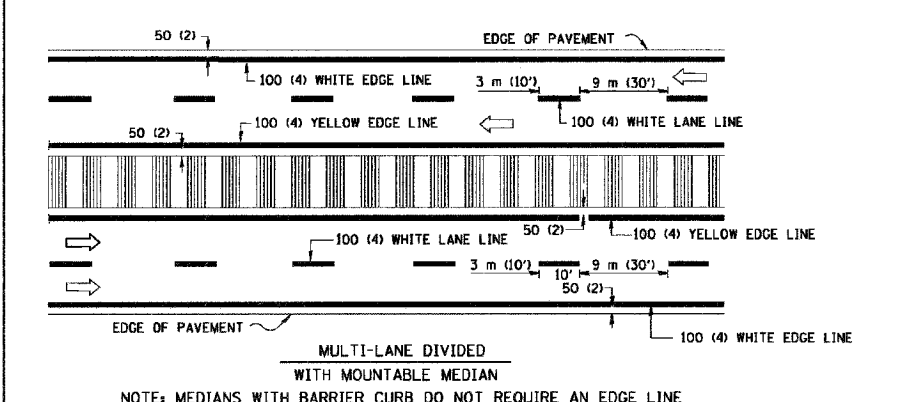
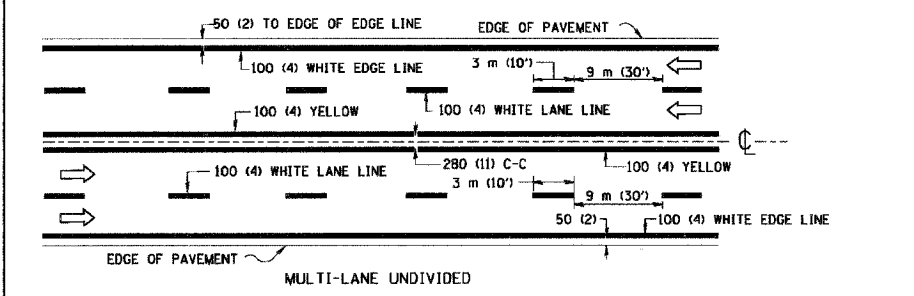
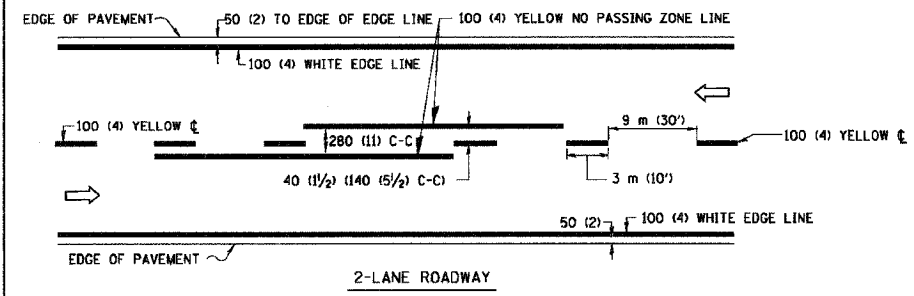

TYPICAL LANE AND EDGE LINE MARKING

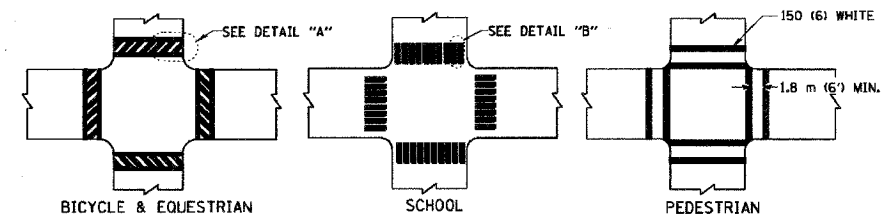

TYPICAL CROSSWALK MARKING

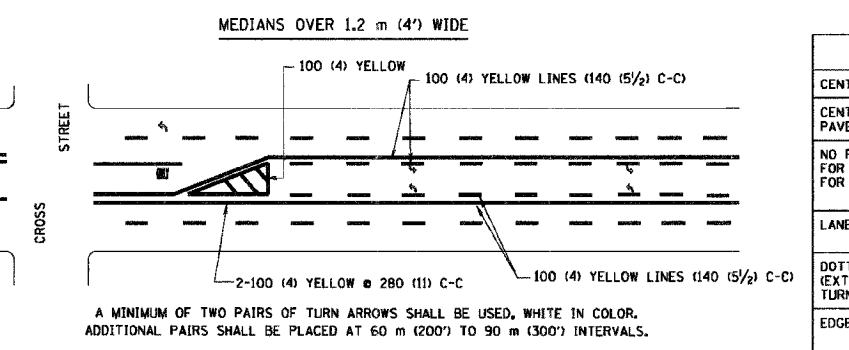
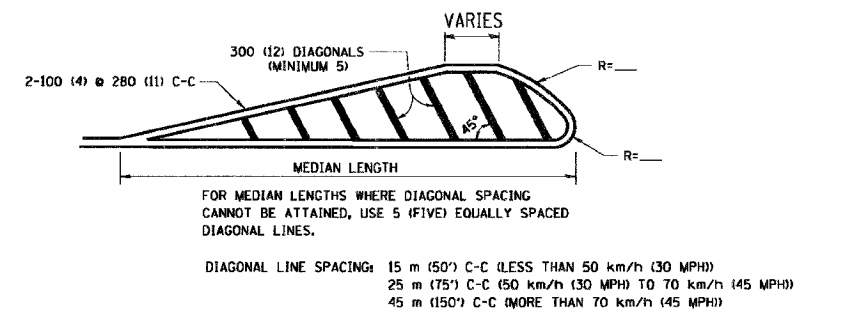
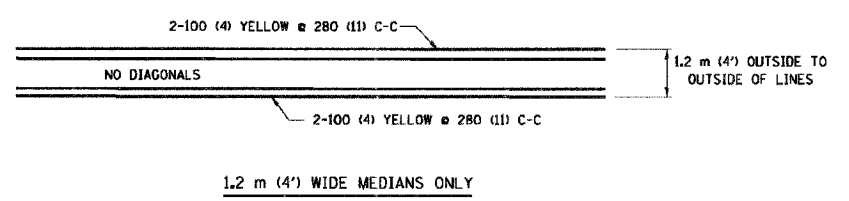

TYPICAL PAINTED MEDIAN MARKING

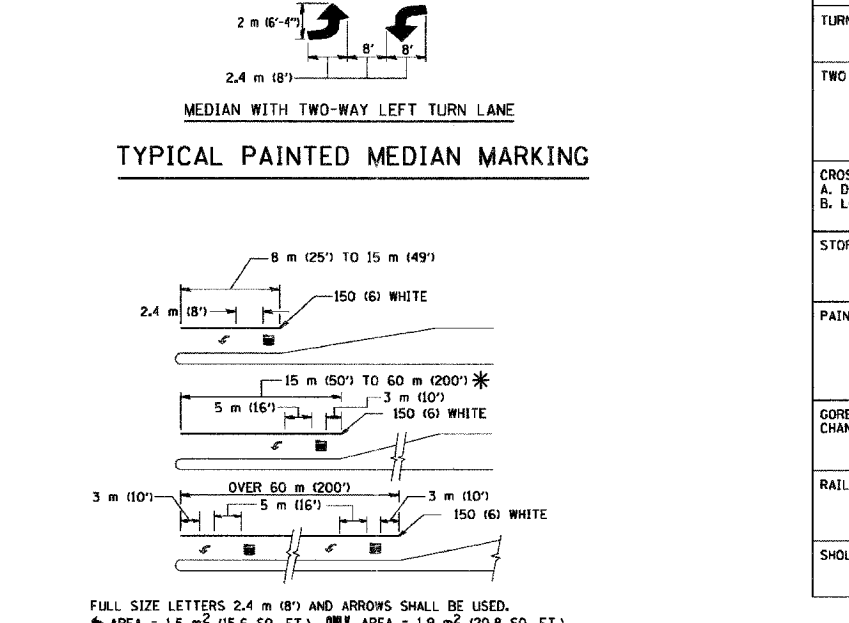

TYPICAL LEFT (OR RIGHT) TURN LANE MARKING

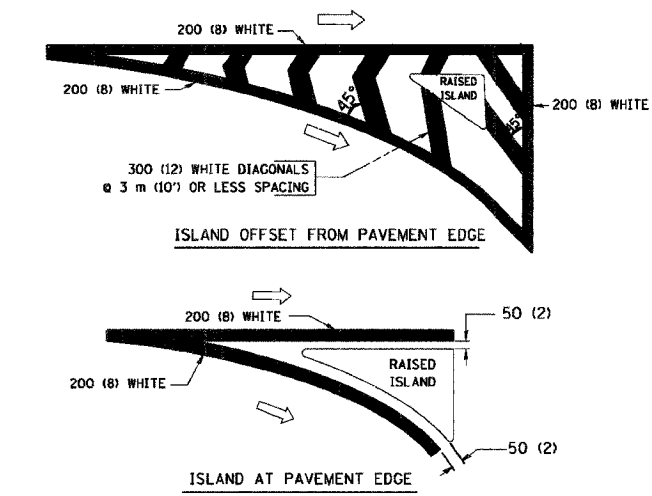

TYPICAL ISLAND MARKING

TYPE OF MARKING	WIDTH OF LINE	PATTERN	COLOR	SPACING / REMARKS
CENTERLINE ON 2 LANE PAVEMENT	100 (4)	SKIP-DASH	YELLOW	3 m (10') LINE WITH 9 m (30') SPACE
CENTERLINE ON MULTI-LANE UNDIVIDED PAVEMENT	2 @ 100 (4)	SOLID	YELLOW	280 (11) C-C
NO PASSING ZONE LINES FOR ONE DIRECTION FOR BOTH DIRECTIONS	100 (4) 2 @ 100 (4)	SOLID SOLID	YELLOW YELLOW	140 (5 1/2) C-C FROM SKIP-DASH CENTERLINE 280 (11) C-C OMIT SKIP-DASH CENTERLINE BETWEEN
LANE LINES	100 (4) 125 (5) ON FREEWAYS	SKIP-DASH SKIP-DASH	WHITE WHITE	3 m (10') LINE WITH 9 m (30') SPACE
DOTTED LINES (EXTENSIONS OF CENTER, LANE OR TURN LANE MARKINGS)	SAME AS LINE BEING EXTENDED	SKIP-DASH	SAME AS LINE BEING EXTENDED	600 (2') LINE WITH 1.8 m (6') SPACE
EDGE LINES	100 (4)	SOLID	YELLOW-LEFT WHITE-RIGHT	OUTLINE MOUNTABLE MEDIANS IN YELLOW; EDGE LINES ARE NOT USED NEXT TO BARRIER CURB
TURN LANE MARKINGS	150 (6) LINE; FULL SIZE LETTERS & SYMBOLS (2.4 m (8'))	SOLID	WHITE	SEE TYPICAL TURN LANE MARKING DETAIL
TWO WAY LEFT TURN MARKING	2 @ 100 (4) EACH DIRECTION 2.4 m (8') LEFT ARROW	SKIP-DASH AND SOLID IN PAIRS	YELLOW WHITE	3 m (10') LINE WITH 9 m (30') SPACE FOR SKIP-DASH; 140 (5 1/2) C-C BETWEEN SOLID LINE AND SKIP-DASH LINE SEE TYPICAL TWO-WAY LEFT TURN MARKING DETAIL
CROSSWALK LINES (PEDESTRIAN) A. DIAGONALS (BIKE & EQUESTRIAN) B. LONGITUDINAL BARS (SCHOOL)	2 @ 150 (6) 300 (12) @ 45° 300 (12) @ 90°	SOLID SOLID SOLID	WHITE WHITE WHITE	NOT LESS THAN 1.8 m (6') APART 600 (2') APART 600 (2') APART SEE TYPICAL CROSSWALK MARKING DETAILS.
STOP LINES	600 (24)	SOLID	WHITE	PLACE 1.2 m (4') IN ADVANCE OF AND PARALLEL TO CROSSWALK, IF PRESENT. OTHERWISE, PLACE AT DESIRED STOPPING POINT, PARALLEL TO CROSSROAD CENTERLINE, WHERE POSSIBLE
PAINTED MEDIANS	2 @ 100 (4) WITH 300 (12) DIAGONALS @ 45° NO DIAGONALS USED FOR 1.2 m (4') WIDE MEDIANS	SOLID	YELLOW; TWO WAY TRAFFIC WHITE; ONE WAY TRAFFIC	280 (11) C-C FOR THE DOUBLE LINE SEE TYPICAL PAINTED MEDIAN MARKING.
GORE MARKING AND CHANNELIZING LINES	200 (8) WITH 300 (12) DIAGONALS @ 45°	SOLID	WHITE	DIAGONALS: 4.5 m (15') C-C (LESS THAN 50 km/h (30 MPH)) 6 m (20') C-C (50 km/h (30 MPH) TO 70 km/h (45 MPH)) 9 m (30') C-C (OVER 70 km/h (45 MPH))
RAILROAD CROSSING	600 (24) TRANSVERSE LINES; "RR" 15 1.8 m (6') LETTERS; 400 (16) LINE FOR "X"	SOLID	WHITE	SEE STATE STANDARD 780001 AREA OF: "R"=0.33m² (3.6 SQ. FT.) EACH "X"=5.0 m² (54.0 SQ. FT.)
SHOULDER DIAGONALS	300 (12) @ 45°	SOLID	WHITE - RIGHT YELLOW - LEFT	15 m (50') C-C (LESS THAN 50 km/h (30 MPH)) 25 m (75') C-C (50 km/h (30 MPH) TO 70 km/h (45 MPH)) 45 m (150') C-C (OVER 70 km/h (45 MPH))

FOR FURTHER DETAILS ON PAVEMENT MARKING REFER TO STANDARD SPECIFICATIONS FOR ROAD AND BRIDGE CONSTRUCTION AND STATE STANDARD 780001.

All dimensions are in millimeters (inches) unless otherwise shown.

REVISIONS	
NAME	DATE
EVERS	03-19-90
T. RAMMACHER	10-27-94
ALEX HOUSEH	10-09-96
ALEX HOUSEH	10-17-96
T. RAMMACHER	01-06-00

ILLINOIS DEPARTMENT OF TRANSPORTATION  
DISTRICT ONE  
TYPICAL PAVEMENT MARKINGS

SCALE: NONE  
DATE: 2/15/2006  
DRAWN BY CADD  
CHECKED BY

PLT DATE = 2/15/2006  
FILE NAME = s:\projects\11111111\11111111.dwg  
PLOT SCALE = 80.000 / 1"  
USER NAME = bshelton

F.A. RTE.	SECTION	COUNTY	TOTAL SHEETS	SHEET NO.
	06-0006-01-5W	DePage	16	16
STA.	TO STA.			
FED. ROAD DIST. NO.	ILLINOIS	FED. AID PROJECT		

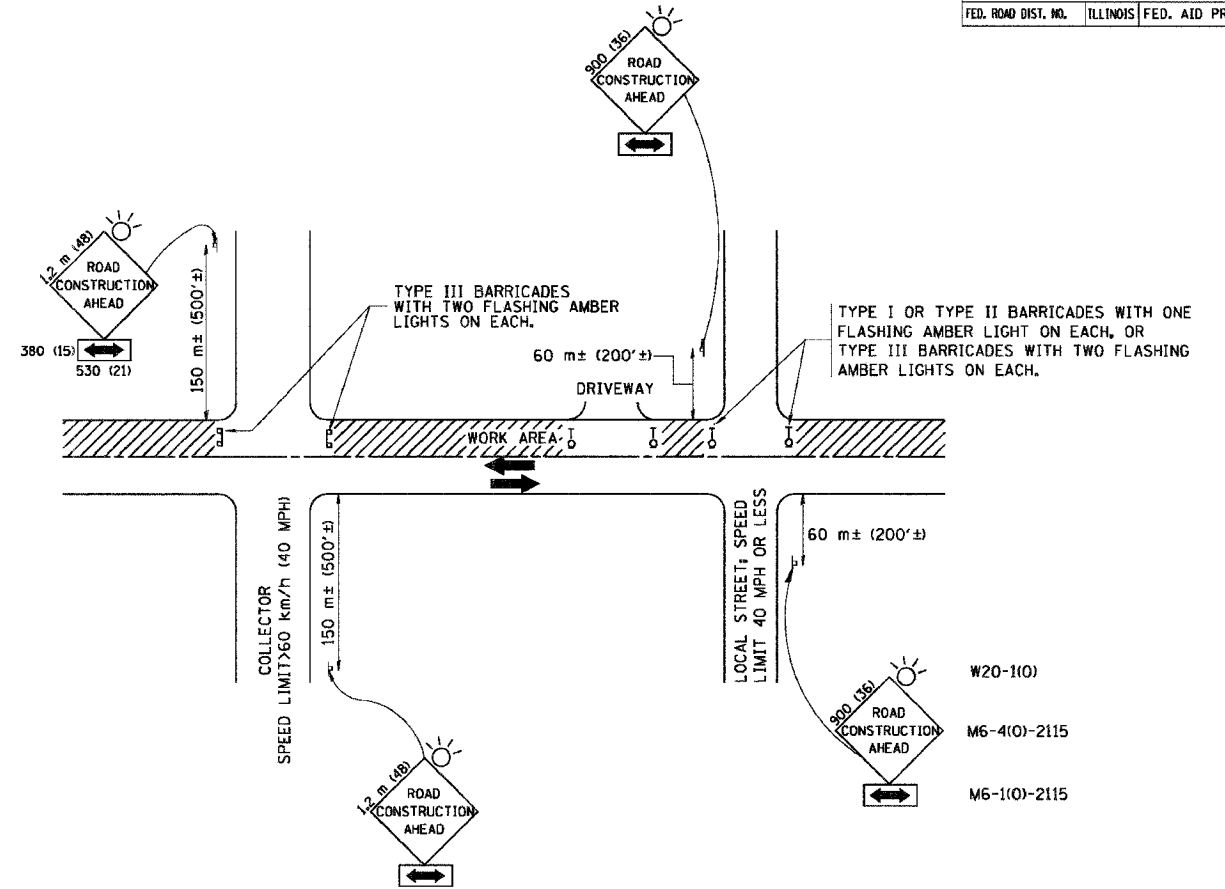

TRAFFIC CONTROL AND PROTECTION FOR SIDE ROADS, INTERSECTIONS, AND DRIVEWAYS

NOTES:

A. FOR NO LANE RESTRICTION ON THE SIDE ROAD OR DRIVEWAYS

- SIDE ROAD WITH A SPEED LIMIT OF 60 km/h (40 MPH) OR LESS AS SHOWN ON THE DRAWING AND AS DIRECTED BY THE ENGINEER:
  - ONE ROAD CONSTRUCTION AHEAD SIGN 900x900 (36x36) WITH A FLASHER AND FLAG MOUNTED ON IT APPROXIMATELY 60 m (200') IN ADVANCE OF THE MAIN ROUTE.
  - THE CLOSED PORTION OF THE MAIN ROUTE SHALL BE PROTECTED BY BLOCKING WITH TYPE I, TYPE II OR TYPE III BARRICADES, 1/3 OF THE CROSS SECTION OF THE CLOSED PORTION.
- SIDE ROAD WITH A SPEED LIMIT GREATER THAN 60 km/h (40 MPH) AS SHOWN ON THE DRAWING AND AS DIRECTED BY THE ENGINEER:
  - ONE ROAD CONSTRUCTION AHEAD SIGN 1.2 m x 1.2 m (48x48) WITH A FLASHER MOUNTED ON IT APPROXIMATELY 150 m (500') IN ADVANCE OF THE MAIN ROUTE.
  - THE CLOSED PORTION OF THE MAIN ROUTE SHALL BE PROTECTED BY BLOCKING WITH TYPE III BARRICADES, 1/2 OF THE CROSS SECTION OF THE CLOSED PORTION.
- WHEN THE SIDE ROAD LIES BETWEEN THE BEGINNING OF THE MAINLINE SIGNING AND THE WORK ZONE, A SINGLE HEADED ARROW (M6-1) SHALL BE USED IN LIEU OF THE DOUBLE HEADED ARROW (M6-4).

B. FOR A LANE CLOSURE ON A SIDE ROAD OR DRIVEWAY:

USE APPLICABLE PORTIONS OF THE TYPICAL APPLICATION OF TRAFFIC CONTROL DEVICES (STD. 701501, STD. 701606 OR THE APPROPRIATE STANDARD). THE SPACING OF SIGNS AND BARRICADES SHALL BE ADJUSTED FOR FIELD CONDITIONS AS DIRECTED BY THE ENGINEER. THE DIRECTIONAL ARROW SHALL BE COVERED OR REMOVED WHEN NO LONGER CONSISTENT WITH THE SIDE ROAD LANE CLOSURE.

C. ADVANCE WARNING SIGNS ARE TO BE OMITTED ON DRIVEWAY UNLESS OTHERWISE NOTED.

D. THE TRAFFIC CONTROL AND PROTECTION FOR SIDE ROADS, INTERSECTIONS, AND DRIVEWAYS SHALL BE INCIDENTAL TO THE COST OF SPECIFIED TRAFFIC CONTROL STANDARDS OR ITEMS.

REVISIONS	
NAME	DATE
LHA	6/89
T. RAMMACHER	09/08/94
J. OBERLE	10/18/95
A. HOUSEH	03/06/96
A. HOUSEH	10/15/96
T. RAMMACHER	01/06/00

ILLINOIS DEPARTMENT OF TRANSPORTATION  
 TRAFFIC CONTROL AND PROTECTION  
 FOR  
 SIDE ROADS, INTERSECTIONS, AND  
 DRIVEWAYS

SCALE:  
 DATE: 2/15/2006

DRAWN BY  
 CHECKED BY  
 TC-10

REVISION DATE: 01/06/00