

STATE OF ILLINOIS
DEPARTMENT OF TRANSPORTATION

F.A.I. RTE.	SECTION	COUNTY	TOTAL SHEET SHEETS	NO.
90/94		COOK	556	448
STA.	TO STA.			
FED. ROAD DIST. NO. 1	ILLINOIS	FED. AID PROJECT		
1818, ETC, 2324.6-1PR-8				62300

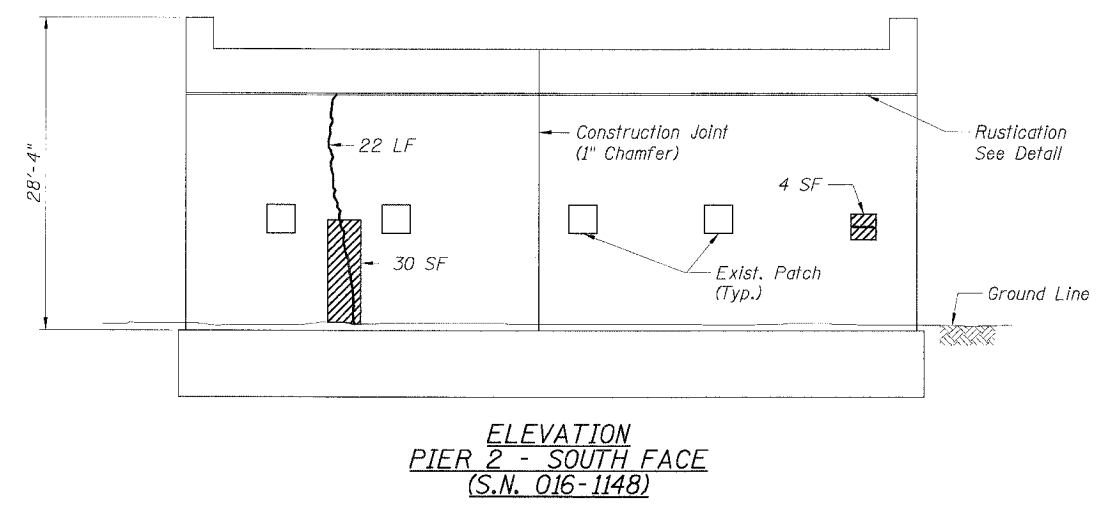
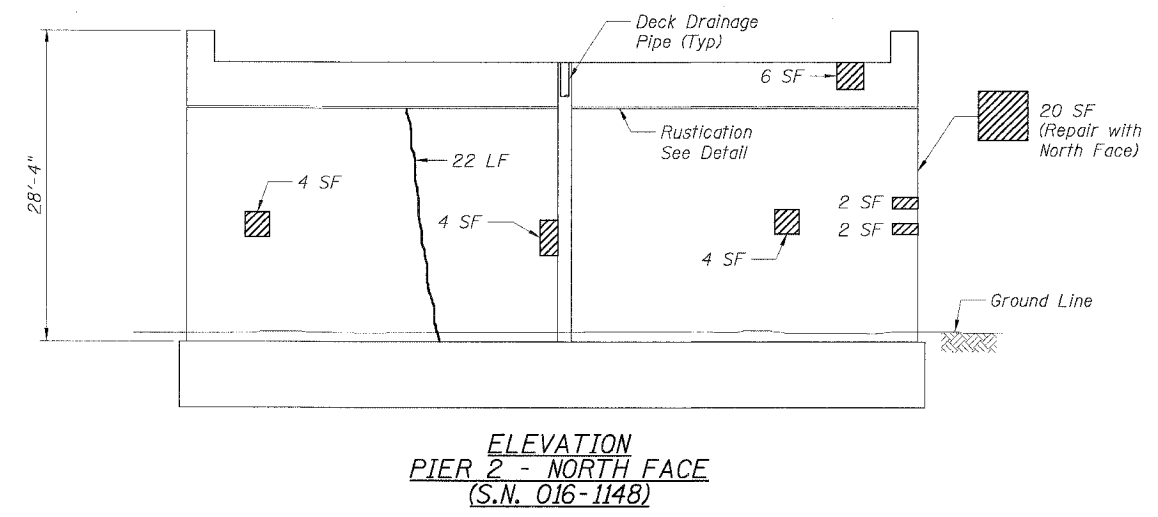
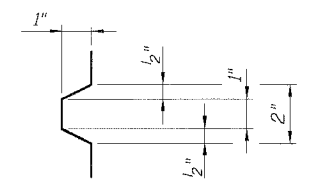
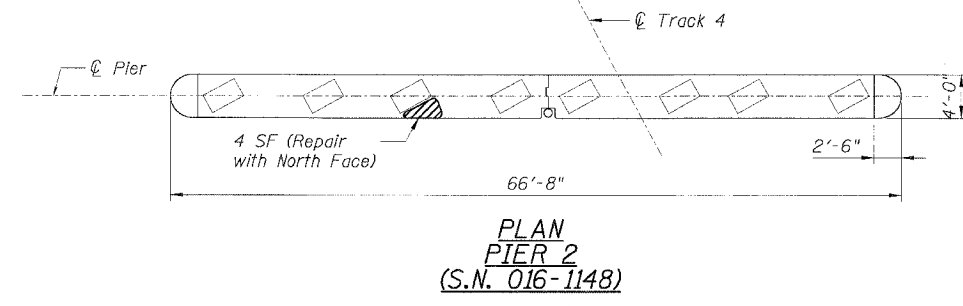

LEGEND

- Area of Formed Concrete Repair (Depth Equal to or Less than 5")
- Area of Formed Concrete Repair (Depth Greater than 5")
- Epoxy Crack Sealing

BILL OF MATERIAL			
Item	Unit	Quantity	
		Pier 2	
		North Face	South Face
Formed Concrete Repair (Depth Equal to or Less Than 5")	Sq Ft	46	30
Formed Concrete Repair (Depth Greater Than 5")	Sq Ft		4
Epoxy Crack Sealing	LF	22	22

REVISIONS	
NAME	DATE

Sheet S2 of 5
ILLINOIS DEPARTMENT OF TRANSPORTATION
F.A.I. 90/94 (DAN RYAN EXPRESSWAY)
**PIER 2 - PLAN AND ELEVATION
SUBSTRUCTURE REPAIRS
METRA BRIDGE (SN 016-1148)
COOK COUNTY**
SCALE: None
DATE: JULY 7, 2005
DRAWN BY: CHD
CHECKED BY: MJP

F:\P\40465\Struct\K_Dwgs\Contr_52300\04_BridgeRepairs\RT030022A62300.sht 6/24/2005 2:20:30 PM