

STATE OF ILLINOIS
DEPARTMENT OF TRANSPORTATION

ROUTE NO.	SECTION	COUNTY	TOTAL SHEETS	SHEET NO.
FAI 90/94	*	COOK	419	185
FED. ROAD DIST. NO.	ILLINOIS PROJECT			
2005-008F				

Sheet No 7
of 8 Sheets

CONTRACT #62560

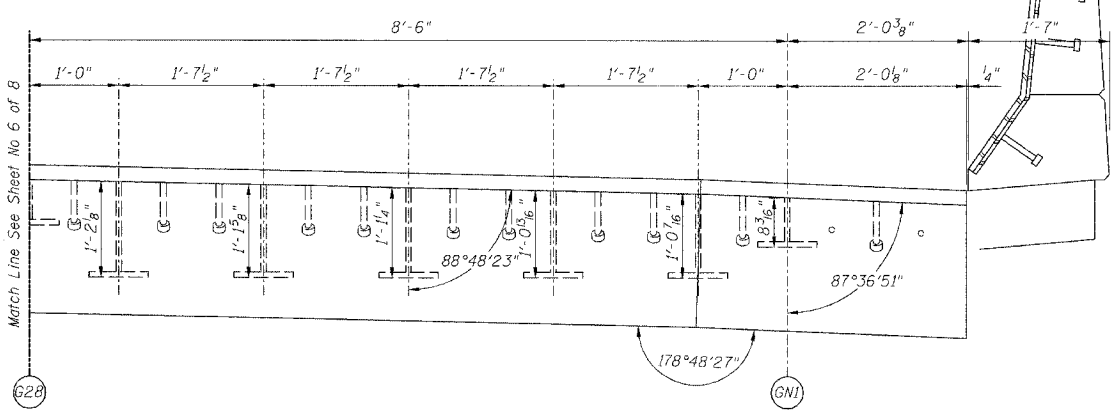

SECTION A-A

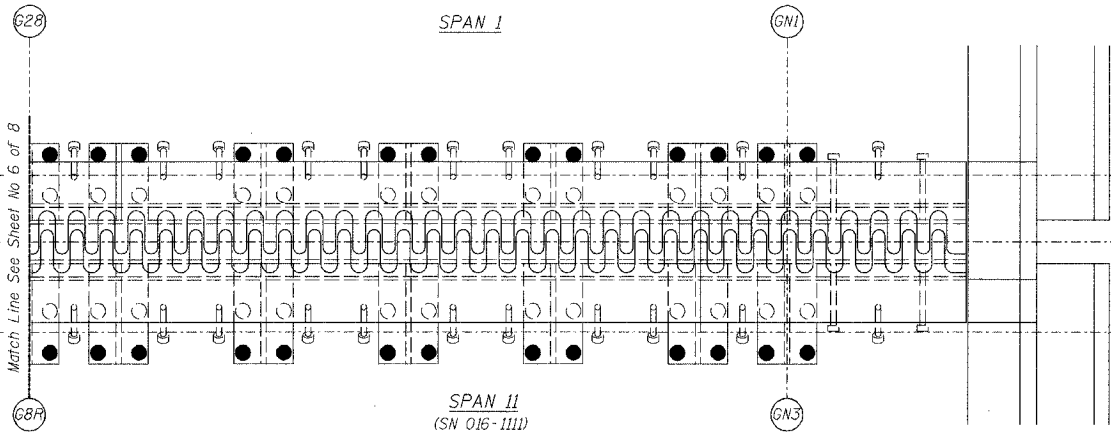

PLAN OF FINGER PLATE AT PIER 1 (NORTHBOUND)

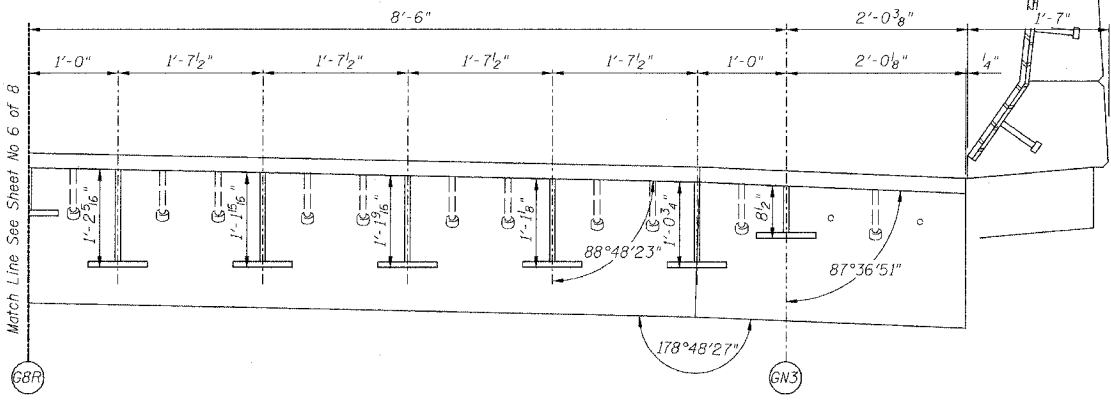

SECTION B-B

For location of splice with respect to fingers see Flame Cutting Diagram.

Note:
For optional splice detail see
flame cutting diagram on Sheet No. 4

PIER NO. 1

REVISIONS			STATE OF ILLINOIS DEPARTMENT OF TRANSPORTATION DIVISION OF HIGHWAYS		DRAWN BY DATE RLK 5/03
No.	DATE	INITIALS			CHECKED BY DATE SDS 5/03
1			FAI RTE 90/94 DAN RYAN EXPRESSWAY		BOOK NUMBER
2			SN 016-1110 (NORTHBOUND)		PROJECT No.
3			SEC 2005-008F COOK COUNTY		4222-3
4					SHEET No.
5					
6					
7					
8					
9					
10					

HOMER L.
CHASTAIN & ASSOCIATES
CONSULTING ENGINEERS
6800 W. BEECH MAINE AVENUE
SUITE 204
CHICAGO, ILLINOIS 60631
312-734-0000
FAX 312-734-0005