

STATE OF ILLINOIS
DEPARTMENT OF TRANSPORTATION

ROUTE NO.	SECTION	COUNTY	TOTAL SHEETS	SHEET NO.	SHEET NO. 6 7 SHEETS
P. A. P. 285	*	COOK	72	52	

*2004-108 BR Contract No. 62853

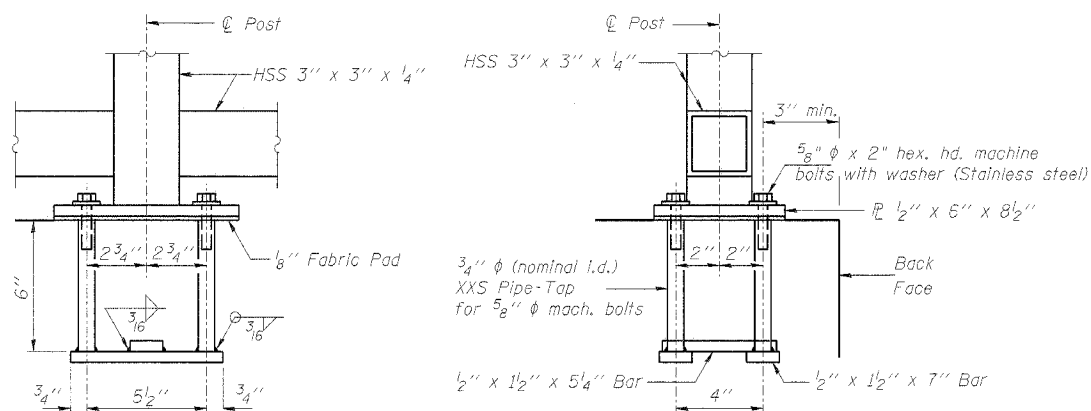
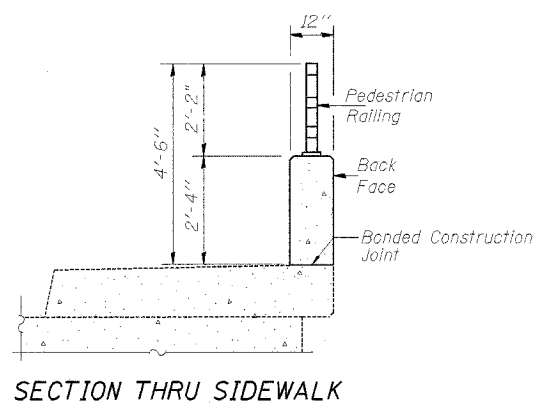
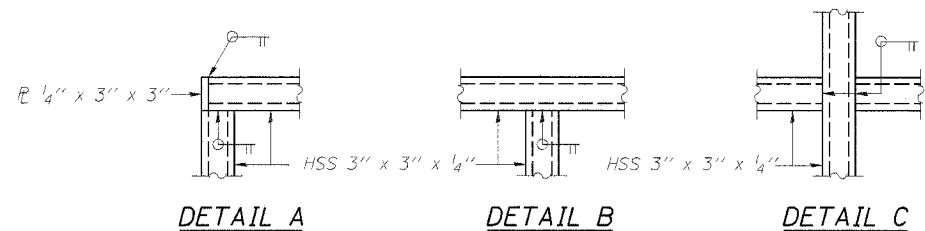

ANCHOR BOLT DETAILS
In lieu of the cast-in-place anchor device shown, the Contractor has the option of drilling and epoxy grouting $\frac{5}{8}$ " ϕ anchor rods. Embedment shall be according to the manufacturer's specifications.

NOTES
Railing shall be according to Section 509 of the Standard Specifications, except as noted, and will be paid for at the Contract Unit Price per foot for Pedestrian Railing.
Hollow structural sections shall conform to the requirements of ASTM designation A 500, Grade B, structural steel tubing.
All other steel shapes and plates shall conform to the requirements of AASHTO M 270 Grade 36.
If the option of drilling and epoxy grouting the anchor rods is chosen, the Contractor shall use the capsule or the adhesive cartridge type anchor rods that have been previously tested and given a prior approval by the Department. The Contractor shall install these anchor rods in pre-drilled holes according to the manufacturer's recommendations and procedures. The capsule or the adhesive cartridge shall be sealed with premeasured amounts of the adhesive chemical.
Space reinforcement to miss anchor rods.
All posts, railing, splices, anchor devices, and bent plates shall be galvanized after shop fabrication according to AASHTO M 111 and ASTM A 385. All bolts, nuts, washers, and anchor rods shall be galvanized according to AASHTO M 232 except stainless steel bolts as noted.
Vent holes for galvanizing shall be placed in the posts and rails at locations that will not allow the accumulation of moisture in the members.

BILL OF MATERIAL

Item	Unit	Quantity
Pedestrian Railing	Foot	65

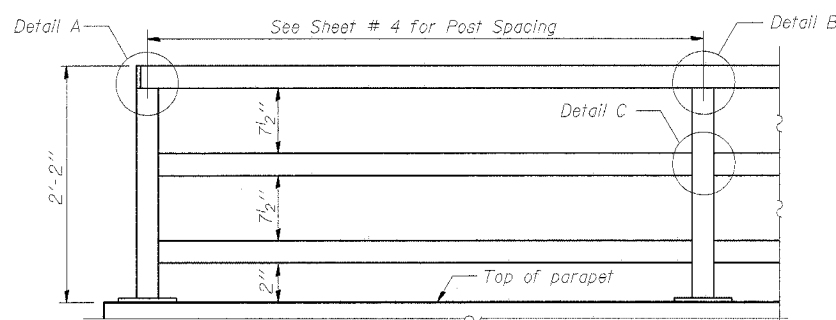

**PEDESTRIAN RAILING
ELEVATION**
(Inside Face of Three Element Rail)

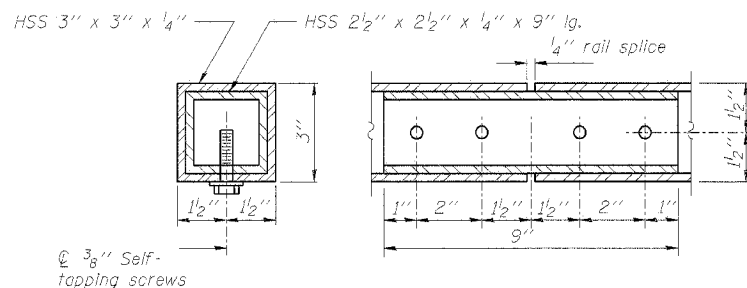
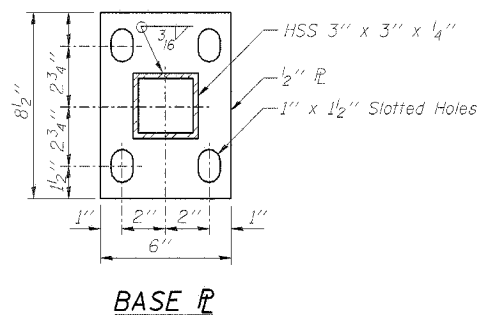

RAIL SPLICE

BRANCO & ZROKA ENGINEERING, P.C.

DESIGNED	LAS
CHECKED	DAZ
DRAWN	SAW
CHECKED	LAS

R-29 (Modified) 9-01-03 (10'-0" Maximum Post Spacing)

**PEDESTRIAN RAILING
EAST FRONTAGE ROAD OVER PALATINE ROAD
FAP 305/PALATINE ROAD
SECTION 2004-108 BR
COOK COUNTY
STA. 0+88.85
STRUCTURE NO. 016-2529**