

STATE OF ILLINOIS  
DEPARTMENT OF TRANSPORTATION

ROUTE NO.	SECTION	COUNTY	SHEET NO.	SHEET NO.
FAP 305	*	Cook	72	65
FED. ROAD DIST. NO. 7		ILLINOIS	FED. AID PROJECT	
			Contract No. 62853 *2004-108 BR	

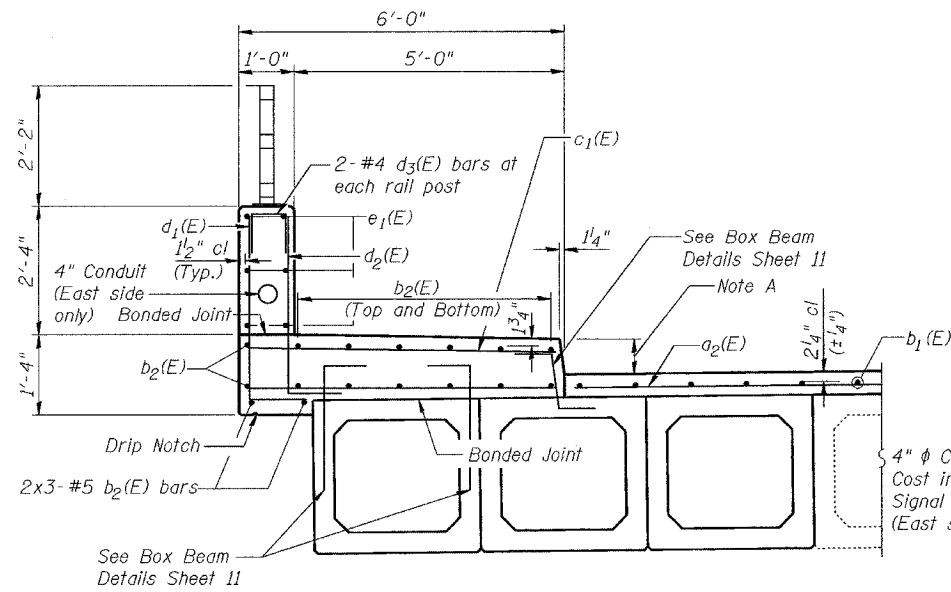

**SECTION THRU PROPOSED PARAPET & SIDEWALK**

Note A: Curb height varies from 6 1/2" @ Sta 949+66.0 to 9" @ Sta 949+68.5, and remains constant 9" from Sta 949+68.5 to Sta 950+32.16.

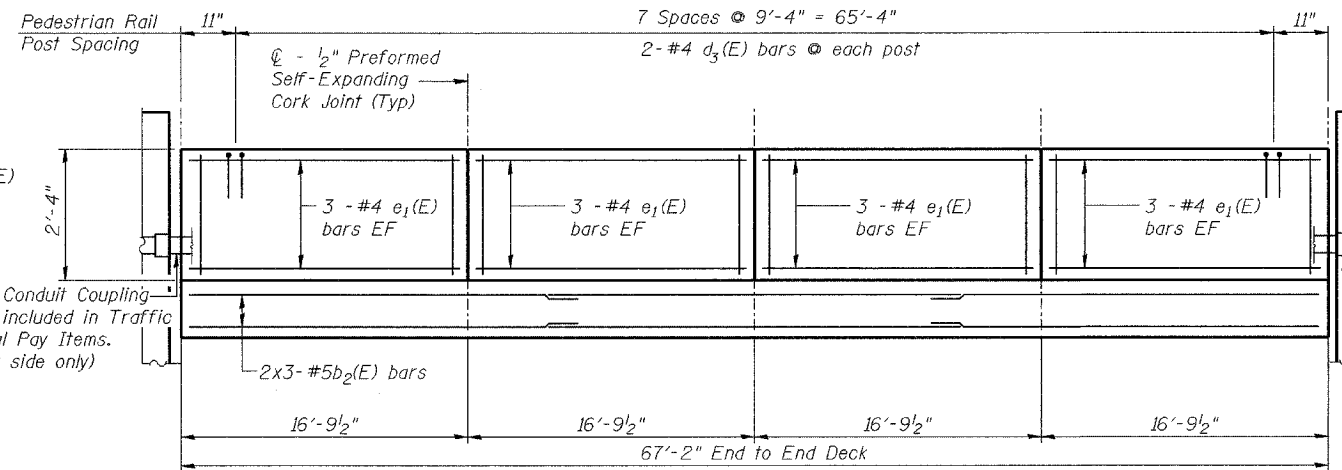

**PARAPET ELEVATION**

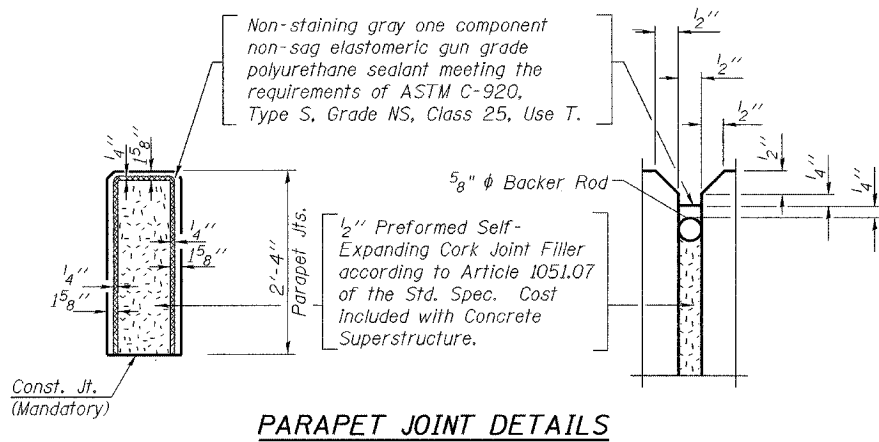
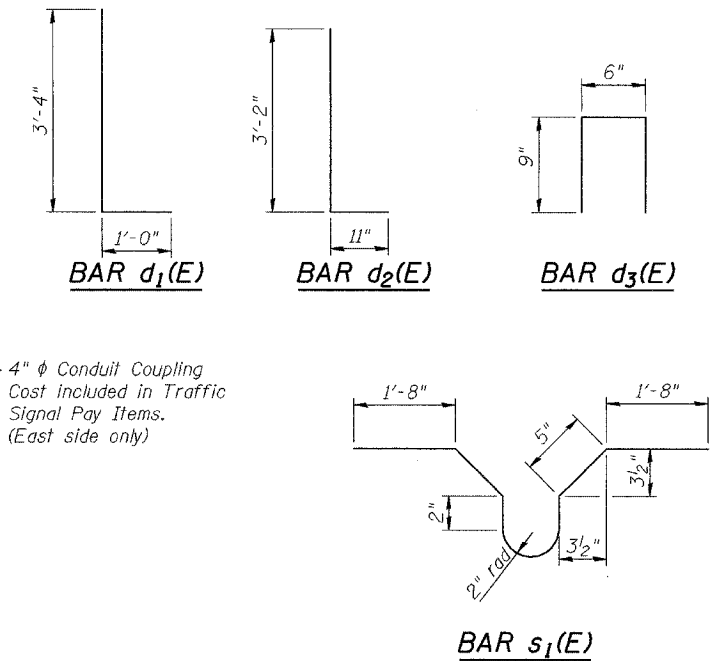

**PARAPET JOINT DETAILS**

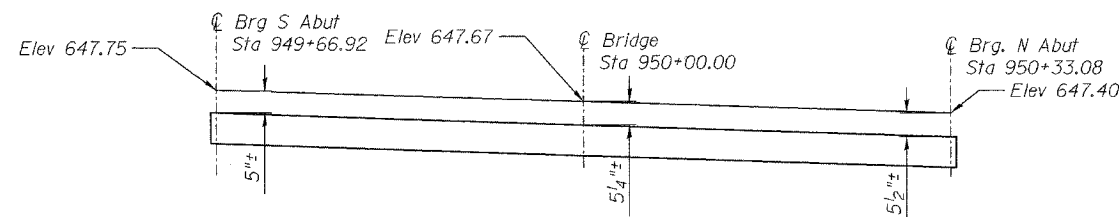

**OVERLAY PROFILE**

(Along Wolf Road)

**BILL OF MATERIAL**

Bar	No.	Size	Length	Shape
a1(E)	68	#4	27'-8"	—
a2(E)	136	#4	14'-8"	—
b1(E)	183	#4	23'-6"	—
b2(E)	96	#5	23'-10"	—
c1(E)	272	#5	5'-8"	—
d1(E)	136	#4	4'-4"	L
d2(E)	136	#6	4'-1"	L
d3(E)	32	#4	2'-0"	U
e1(E)	48	#4	16'-6"	—
s1(E)	68	#4	5'-0"	∩
Item		Unit	Quantity	
Bridge Deck Grooving		Sq Yd	433	
Protective Coat		Sq Yd	573	
Concrete Superstructure		Cu Yd	59.4	
Reinforcement Bars, Epoxy Coated		Pound	11,490	
Concrete Wearing Surface		Sq Yd	433	
Bar Splicers		Each	136	

Reinforcement bars designated (E) shall be epoxy coated.

DESIGNED	BPS
CHECKED	KFA
DRAWN	MJB
CHECKED	GSP

**SUPERSTRUCTURE DETAILS**  
**WOLF RD. OVER PALATINE RD.**  
**F.A.P. RTE. 305 SECT. 2004-108 BR**  
**COOK COUNTY**  
**STATION 950+00.00**  
**STRUCTURE NO. 016-0680**

Notes:  
For Plan and Cross Section, See Sheet 6.