

STATE OF ILLINOIS  
DEPARTMENT OF TRANSPORTATION

ROUTE NO.	SECTION	COUNTY	SHEET NO.	SHEET NO. 9
FAP 305	*	Cook	72 67	14 SHEETS
FED. ROAD DIST. NO. 7		ILL. PROJ. NO.		FED. AID PROJECT
		Contract No. 62853		*2004-108 BR

**NOTES**

Railing shall be according to Section 509 of the Standard Specifications, except as noted, and will be paid for at the Contract Unit Price per foot for Pedestrian Railing.

Hollow structural sections shall conform to the requirements of ASTM designation A 500, Grade B, structural steel tubing.

All other steel shapes and plates shall conform to the requirements of AASHTO M 270 Grade 36.

If the option of drilling and epoxy grouting the anchor rods is chosen, the Contractor shall use the capsule or the adhesive cartridge type anchor rods that have been previously tested and given a prior approval by the Department. The Contractor shall install these anchor rods in pre-drilled holes according to the manufacturer's recommendations and procedures. The capsule or the adhesive cartridge shall be sealed with pre-measured amounts of the adhesive chemical.

Space reinforcement to miss anchor rods.

All posts, railing, splices anchor devices, and bent plates shall be galvanized after shop fabrication according to AASHTO M 111 and ASTM A 385. All bolts, nuts, washers, and anchor rods shall be galvanized according to AASHTO M 232 except stainless steel bolts as noted.

Vent holes for galvanized shall be placed in the posts and rails at locations that will not allow the accumulation of moisture in the members.

**BILL OF MATERIAL**

ITEM	UNIT	QUANTITY
Pedestrian Railing	Foot	135

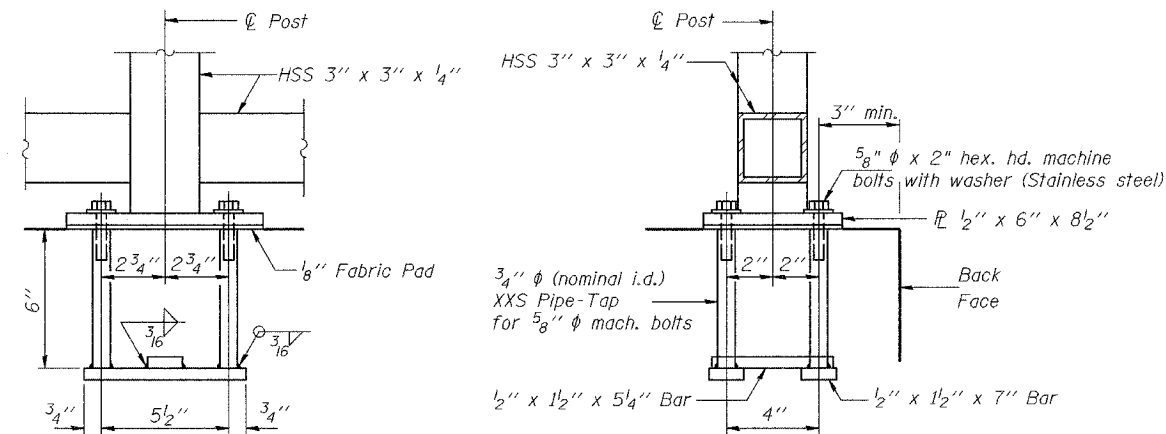
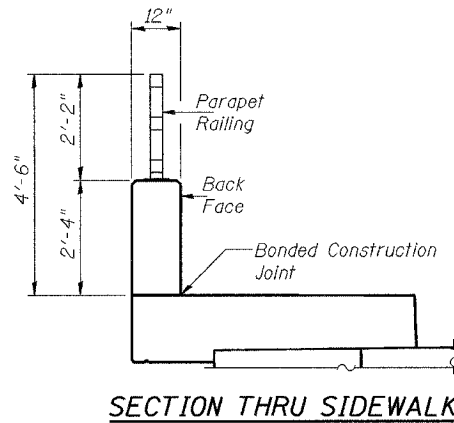
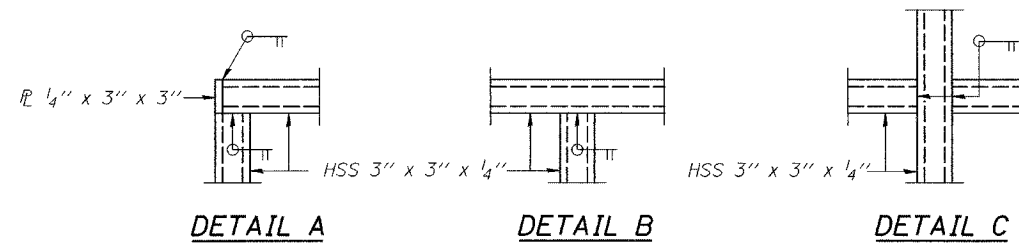

**ANCHOR BOLT DETAILS**

In lieu of the cast-in-place anchor device shown, the Contractor has the option of drilling and epoxy grouting 5/8"  $\phi$  anchor rods. Embedment shall be according to the manufacturer's specifications.

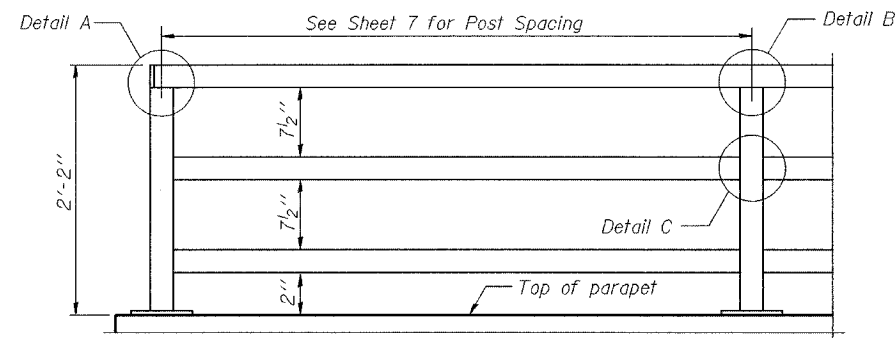

**PARAPET RAILING  
ELEVATION**

(Inside Face of Three Element Rail)

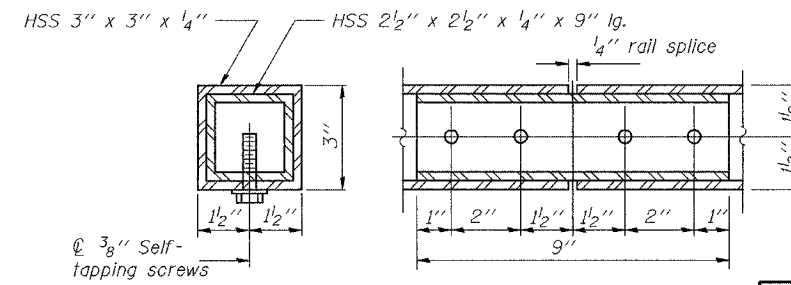
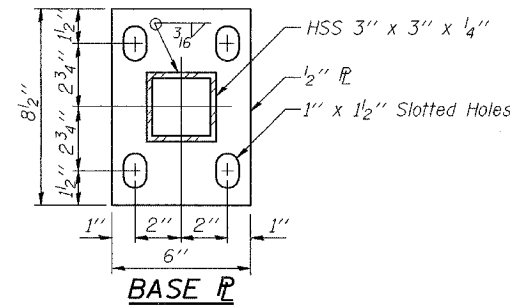

**RAIL SPLICE**

DESIGNED	BPS
CHECKED	KFA
DRAWN	BPS
CHECKED	GSP

R-29 (Modified) 9-01-03 (10'-0" Maximum Post Spacing)

**PEDESTRIAN RAILING**  
**WOLF RD. OVER PALATINE RD.**  
**F.A.P. RTE. 305 SECT. 2004-108 BR**  
**COOK COUNTY**  
**STATION 950+00.00**  
**STRUCTURE NO. 016-0680**