

| | | | | |
|---------------------|-------------|------------------|--------------|-----------|
| F.A. RTE. | SECTION | COUNTY | TOTAL SHEETS | SHEET NO. |
| 290 | 0305-302K-3 | COOK | 55 | 37 |
| STA. | | TO STA. | | |
| FED. ROAD DIST. NO. | ILLINOIS | FED. AID PROJECT | | |

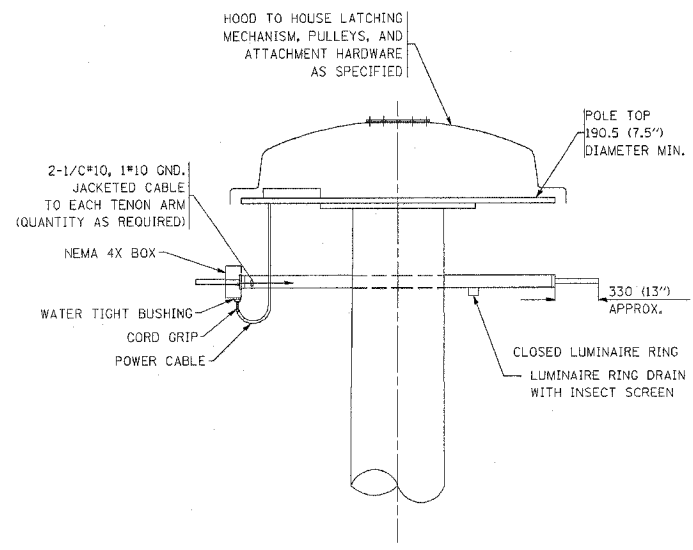

DETAIL-"D"

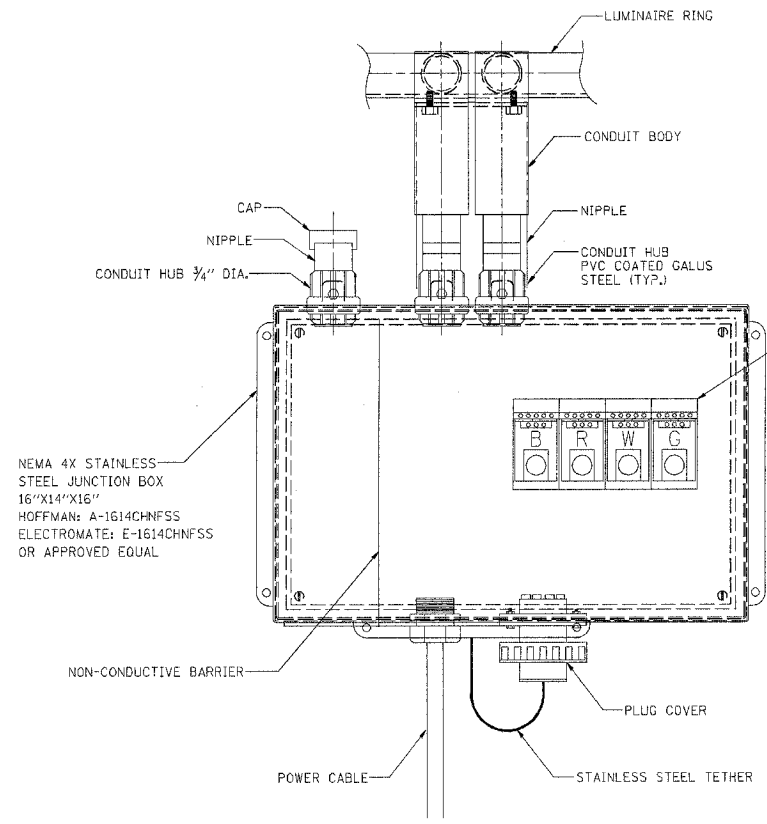

FRONT VIEW

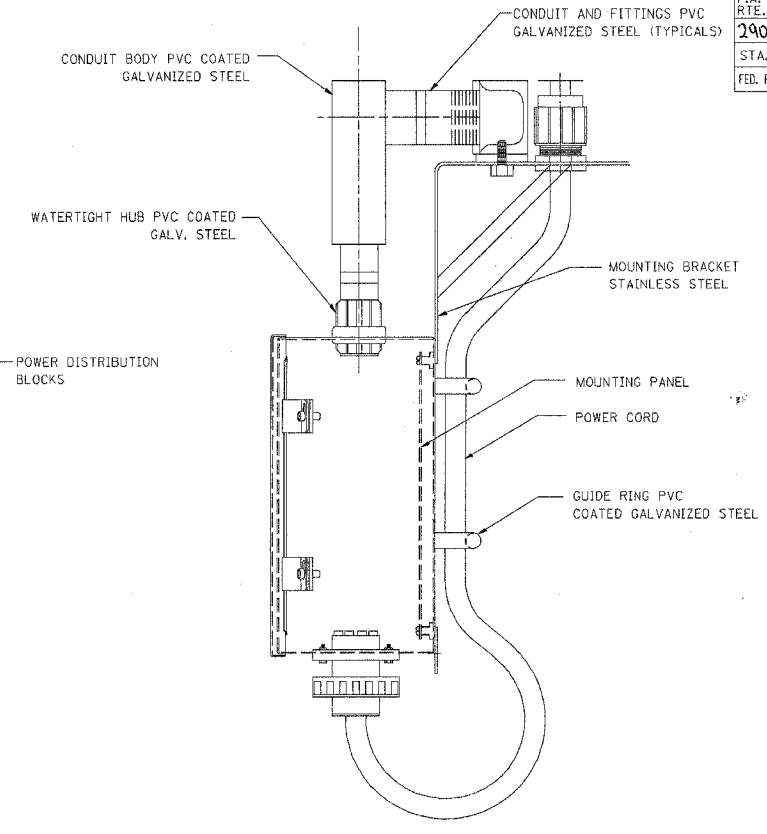

SIDE VIEW

LUMINAIRE RING TERMINAL BOX

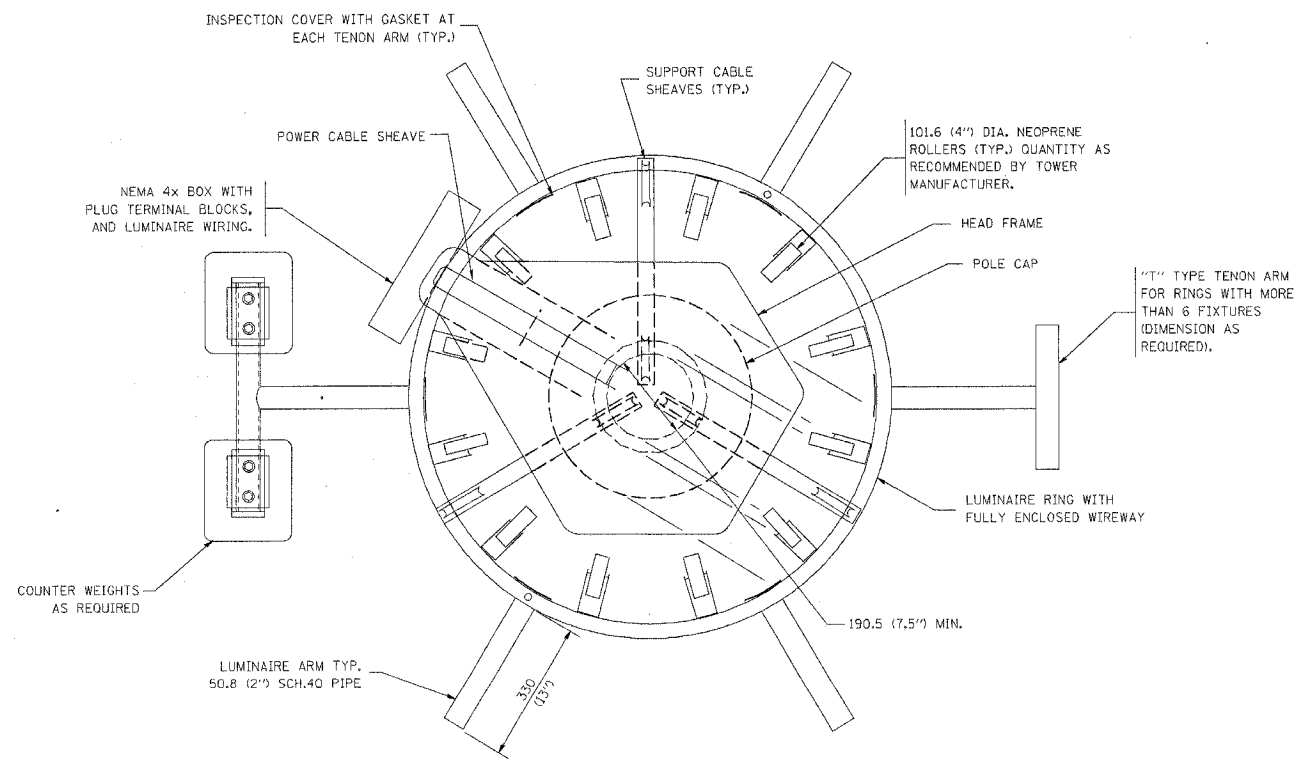

SECTION A-A

NOTES:

- LUMINAIRE WIRES SHALL EXTEND 609 MM (24 INCHES) LONGER THAN THEIR RESPECTIVE TENON ARM AND SHALL BE TRAINED BACK INTO THE ARM WHICH SHALL THEN BE CLOSED WITH A CAP AS SPECIFIED. ALL WIRES SHALL BE CAPPED WITH HEAT SHRINK INSULATING BOOTS, CRIMP CAPS ARE UNACCEPTABLE. ALL RING WIRES SHALL BE TAGGED WITH WIRE MARKERS AT BOTH ENDS. THE TENON ARMS SHALL ALSO BE TAGGED CORRESPONDING TO THE WIRING CONTAINED WITHIN.
- SPLICING WILL NOT BE ALLOWED WITHIN THE LUMINAIRE RING.
- ALL TOWER SHAFT HARDWARE, SUCH AS GROUND LUGS, JUNCTION BOXES, HARDWARE FOR THE HANDHOLE DOOR, INCLUDING THE HANDLE/LATCH MECHANISM, HINGE AND DOOR STOP, SHALL BE STAINLESS STEEL. ALL CONDUIT AND CONDUIT FITTINGS SHALL BE PVC COATED GALVANIZED STEEL.
- ALL MULTI-CONDUCTOR CABLES SHALL BE FITTED WITH A HEAT-SHRINK MULTI-LEG BOOT. THE BOOT SHALL MEET MILITARY SPECIFICATION MIL-I-81765/1.

E-500

| REVISIONS | | ILLINOIS DEPARTMENT OF TRANSPORTATION |
|-----------|---------------------------|---|
| NAME | DATE | |
| | | HIGH MAST LIGHT TOWER 27m TO 36m (90FT TO 120FT) SHEET 2 OF 3 |
| | | |
| | | |
| | | |
| | | |
| | | |
| | | |
| | | |
| | | |
| | | |
| SCALE: | VERT. NONE HORIZ. NONE | DRAWN BY |
| DATE | | CHECKED BY |