

ROUTE NO.	SECTION	COUNTY	TOTAL SHEETS	SHEET
F.A.S. 585	02-00063-00-BR	BROWN	16	8
FED. ROAD DIST. NO.	ILLINOIS	FED. AID PROJECT	BHS-585(104)	

CONTRACT NO. 93399

CAMP CREEK  
REBUILT 200\_ BY  
BROWN COUNTY  
SEC. 02-00063-00-BR  
C.H. 11 / F.A.S. 585  
F.A. PROJ. BHS-585(104)  
STR. NO. 005-3020 / LOADING HS 20

NAME PLATE  
See Std. 515001

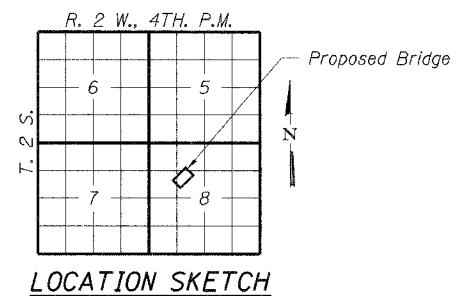

**GENERAL NOTES**

Layout of riprap may be varied in the field to suit ground conditions as directed by the Engineer.

All proposed construction activity shall be in accordance with Nationwide Permit number 14 of the Department of the Army authorized under Section 404 of the Clean Water Act. The IEPA has issued Section 401 Water Quality Certification for this activity. See Special Provisions for conditions.

Plan dimensions and details relative to existing structure have been taken from field survey and are subject to nominal construction variations. It shall be the Contractor's responsibility to verify such dimensions and details in the field and make necessary approved adjustments prior to construction or ordering of materials. Such variations shall not be cause for additional compensation for a change in the scope of the work, however, the Contractor will be paid for the quantity actually furnished at the unit price bid for the work.

The Contractor shall excavate behind the abutments to the elevations shown prior to the removal of the existing deck. The excavation shall be backfilled with Porous Granular Backfill after superstructure rehabilitation has been completed. The excavation required behind the abutments shall be considered incidental to Porous Granular Backfill.

Removal of existing bridge rail will be included in the pay item Removal of Existing Concrete Deck.

Fasteners shall be high strength bolts. (AASHTO M164, Type 3 in unpainted areas and mechanically galvanized AASHTO M 164, Type 1 or 2 in painted areas). Bolts 3/4" φ, open holes 5/8" φ, unless otherwise noted.

Calculated weight of Structural Steel = 580 Lbs. This includes new anchor bolts (at both abutments) and replacement bearing plates (at both abutments. Where determined necessary by the Engineer after Concrete Removal.)

Field welding of construction accessories to beams will not be permitted.

Reinforcement bars shall conform to the requirements of AASHTO M31 or M322 Grade 60.

Bridge Deck Grooving shall be completed on the surface area of the bridge.

Protective Coat shall be applied to the bridge surface and fascias.

All construction joints shall be bonded.

Painting of existing steel when entire structure will be blast cleaned: Cleaning and painting of the existing structural steel shall be as specified in the special provision for "Cleaning and Painting Existing Steel Structures". All existing steel shall be cleaned per Near White Blast Cleaning - SSPC-SP10. All existing steel shall be painted according to the requirements of Paint System 1 - 0Z/E/U. The color of the final finish coat for all interior steel surfaces shall be Gray, Munsell No 5B 7/1. The color of the final finish coat for the exterior and bottom flange of the fascia beams shall be Gray, Munsell No 5B 7/1.

GPI and GP2 painting contractor certification are not required for this project.

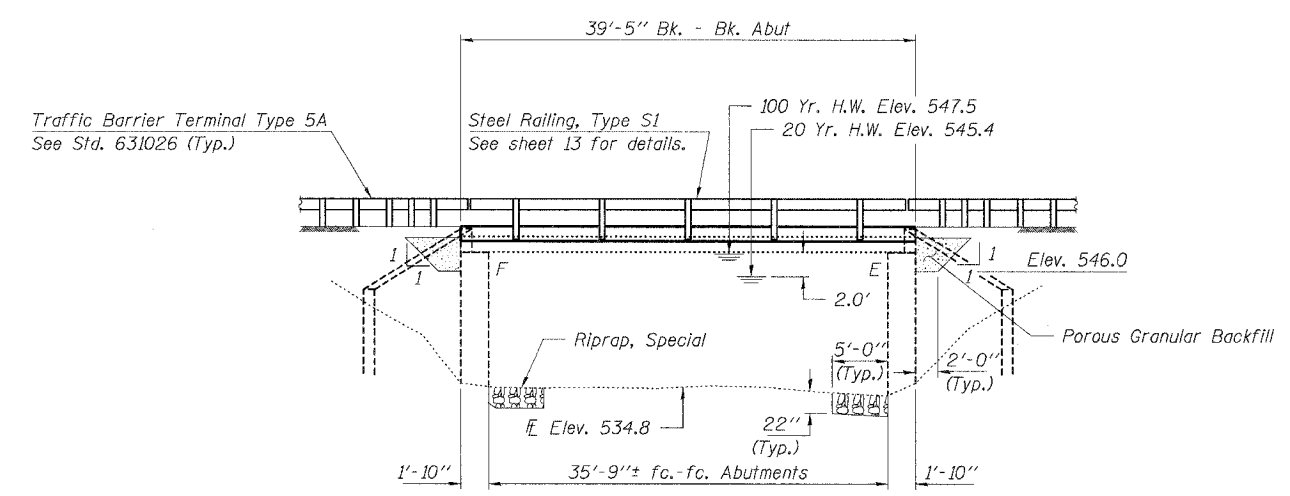

**ELEVATION**

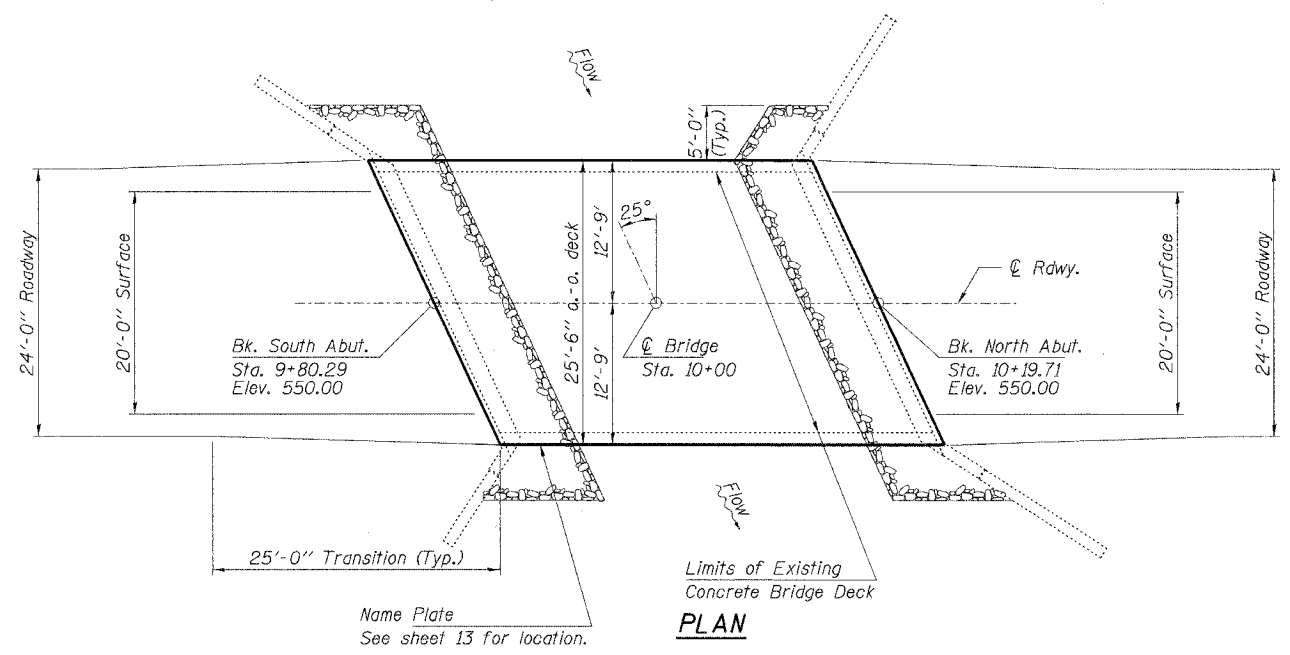

**PLAN**

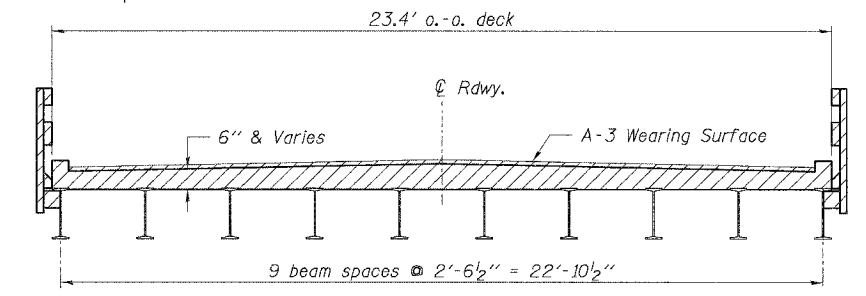

**EXISTING BRIDGE SECTION**

Indicates limits of removal of existing concrete deck. See special provisions.

**TOTAL BILL OF MATERIAL**

ITEM	UNIT	SUPER	SUB	TOTAL
Removal of Existing Concrete Deck	Each	1		1
Concrete Removal	Cu. Yd.		3.4	3.4
Concrete Superstructure	Cu. Yd.	30.9		30.9
Bridge Deck Grooving	Sq. Yd.	112		112
Protective Coat	Sq. Yd.	124		124
Furnishing and Erecting Structural Steel	L. Sum	1		1
Stud Shear Connectors	Each	540		540
Cleaning and Painting Steel Bridge	L. Sum	1		1
Containment and Disposal of Lead Paint Cleaning Residues	L. Sum	1		1
Reinforcement Bars, Epoxy Coated	Pound	7,790	155	7,945
Steel Railing, Type S1	Foot	86		86
Name Plates	Each	1		1
Porous Granular Backfill	Ton		60	60
Riprap, Special	Ton		50	50

**DESIGN STRESSES**

**FIELD UNITS**

f'c = 3,500 psi  
fy = 60,000 psi (Reinf.)  
fy = 30,000 psi (Existing Structural Steel)  
fy = 36,000 psi (Proposed Structural Steel)  
n = 8

Loading HS 20-44  
Design Specifications: 2002 AASHTO & all applicable interims.  
25#/Sq. Ft. included in dead load for future wearing surface.

**SEISMIC DATA**

Seismic Performance Category (SPC) = A  
Bedrock Acceleration Coefficient (A) = 0.045g  
Site Coefficient (S) = 1.0

**WATERWAY INFORMATION**

Flood		Freq. Yr.	Q C.F.S.	Opening Sq. Ft.	Natural H.W.E.	Head - Ft.	Headwater El.
Design	Base	20	1,730	320	545.4	0.2	545.6
		100	2,650	390	547.5	0.6	548.1
		500	3,570	390	547.8	1.1	548.9

Drainage Area = 8.1 Sq. Mi. Low Grade Elev. 549.65 @ Sta. 12+00

I certify that to the best of my knowledge, information and belief, this bridge design is structurally adequate for the design loading shown on the plans. The design is an economical one for the style of structure and complies with requirements of the current "AASHTO Standard Specifications for Highway Bridges"

Steven W. Megginson 6-10-05  
ILLINOIS STRUCTURAL NO. 6064

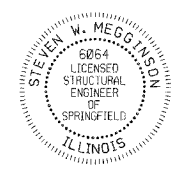

Expires 11-30-06

**HLR**  
Rice, Berry and Associates  
A Division of Hampton, Lenzini and Renwick, Inc.  
Civil & Structural Engineers  
801 S. Durkin Drive  
Springfield, Illinois 62704  
217-546-3400  
P.O. Box 1036  
DuQuoin, Illinois 62832  
618-790-4637  
DESIGNED: T.P.L. CHECKED: S.W.M. DRAWN: D.T.M.

**GENERAL PLAN AND ELEVATION**  
SECTION 02-00063-00-BR  
C.H. 11 / F.A.S. 585  
BROWN COUNTY  
STRUCTURE NO. 005-3020 / STATION 10+00