

STATE OF ILLINOIS  
DEPARTMENT OF TRANSPORTATION

ROUTE	SECTION	COUNTY	TOTAL SHEETS	SHEET NO.
9477	05-00051-00-RP	FRANKLIN	23	1
CITY OF WEST FRANKFORT		CLEVELAND STREET		

CONTRACT NO. 99234

PLANS FOR PROPOSED  
FEDERAL AID URBAN SYSTEM

FUNCTIONAL CLASS, COLLECTOR  
ADT (02) = 1500  
DESIGN SPEED = 30 M.P.H.

**INDEX OF SHEETS**

- 1 COVER SHEET
- 2 TYPICAL SECTIONS
- 3 SUMMARY OF QUANTITIES
- 3-5 SCHEDULES OF QUANTITIES
- 6-7 STORM WATER POLLUTION PREVENTION PLAN
- 8-13 PLAN-PROFILE SHEETS
- 14 DETAILS - INLET SPECIAL, TYPE 1  
- INLET SPECIAL, TYPE 3, 5'
- 15-21 CROSS SECTIONS
- 22 WATER DETAILS
- 23 SEPARATION DETAILS

**CITY OF WEST FRANKFORT**

F.A.U. ROUTE 9477 (CLEVELAND STREET)  
SECTION 05-00051-00-RP  
PROJ M-5071(11)  
C-99-540-05

FRANKLIN COUNTY  
CLEVELAND STREET

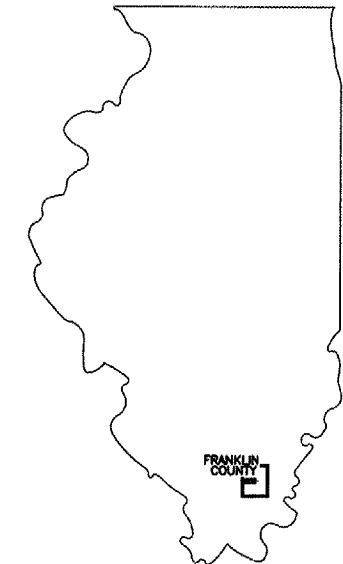
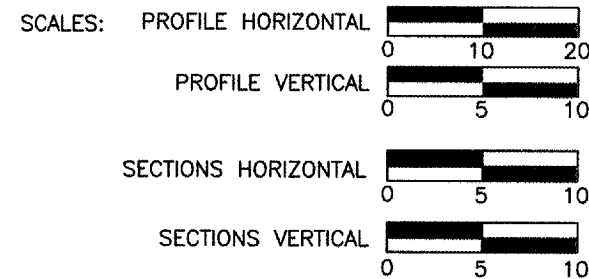

LOCATION OF SECTION INDICATED THUS -

**STANDARDS**

- 280001-02 TEMPORARY EROSION CONTROL
- 420001-06 PAVEMENT JOINTS
- 424001-04 CURB RAMPS FOR SIDEWALKS
- 542606 R.C. PIPE TEE
- 602401 MANHOLE TYPE A
- 602601 P.R.C. FLAT TOP SLAB
- 602701 CAST IRON STEPS
- 604001-02 FRAME AND LID, TYPE 1
- 701501-03 TRAFFIC CONTROL
- 702001-05 TRAFFIC CONTROL DEVICES
- 720001 SIGN PANEL MOUNTING
- 720006 SIGN PANEL ERECTION
- 780001-01 PAVEMENT MARKINGS
- BLR 10-5 PCC PAVEMENT SPECIAL
- BLR 21-6 TRAFFIC CONTROL
- BLR 22-4 TRAFFIC CONTROL

**PROPOSED IMPROVEMENTS**

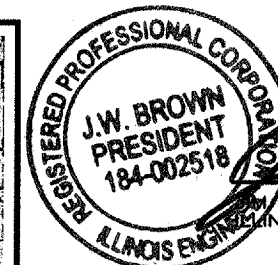
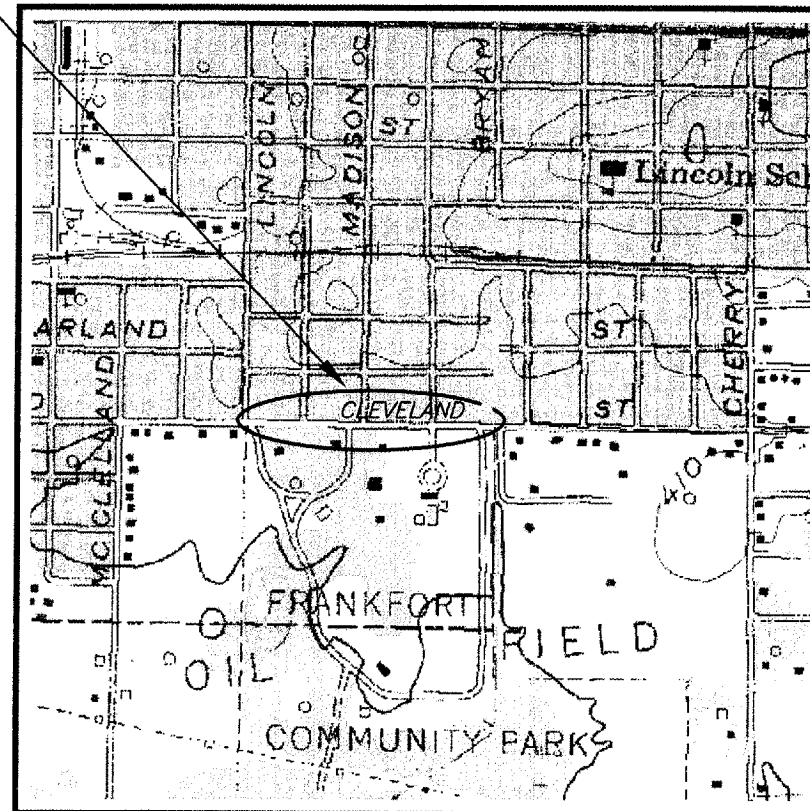

*J.W. Brown*  
J.W. BROWN JULY 25, 2005  
ILLINOIS REGISTERED PROFESSIONAL ENGINEERING CORPORATION  
NUMBER 184-002518  
EXPIRES NOV. 30, 2005

ALL EXISTING UTILITIES AND LOCATIONS TO BE  
CONFIRMED BY J.U.L.I.E. 800-892-0123

**BR** BROWN & ROBERTS, INC.  
CONSULTING ENGINEERS & LAND SURVEYORS  
1 WEST RIDGE ROAD HARRISBURG, IL 62946 (618) 252-8111

**CONTRACT NO. 99234**

JOB NO. 05042

LOCATION MAP  
LENGTH OF IMPROVEMENTS = 1281.00 FT. = 0.243 MI.

STATE OF ILLINOIS  
DEPARTMENT OF TRANSPORTATION

APPROVED July 25 2005  
*Larry D. Warren*  
LOCAL AGENCY REPRESENTATIVE

PASSED JULY 26 2005  
*Don W. Hulett*  
ENGINEER OF LOCAL STREETS AND ROADS

APPROVED July 27 2005  
*Mary C. Lamie*  
MARY C. LAMIE, P.E.  
DEPUTY DIRECTOR OF HIGHWAYS  
REGION FIVE ENGINEER

ROUTE	SECTION	COUNTY	TOTAL SHEETS	SHEET NO.
9477	05-00051-00-RP	FRANKLIN	23	2
CITY OF WEST FRANKFORT		CLEVELAND STREET		

CONTRACT NO. 99234

**PAVEMENT DESIGN DATA**

CLASS II STREET  
 DESIGN PERIOD - 20 YEARS  
 STRUCTURAL DESIGN TRAFFIC (SDT)  
 YEAR - 2022  
 P.C. - 1765  
 S.U. - 25  
 M.U. - 10  
 PERCENT OF PAVEMENT S.D.T IN DESIGN LANE  
 P.C. 50 S.U. 50 M.U. 50  
 SOIL SUPPORT VALUE (I.B.R.) - 2.2  
 TRAFFIC FACTOR (T.F.) - 0.1  
 PAVEMENT STRUCTURE MATERIALS:  
 P.C.C. PAVEMENT MINIMUM THICKNESS 7 INCHES

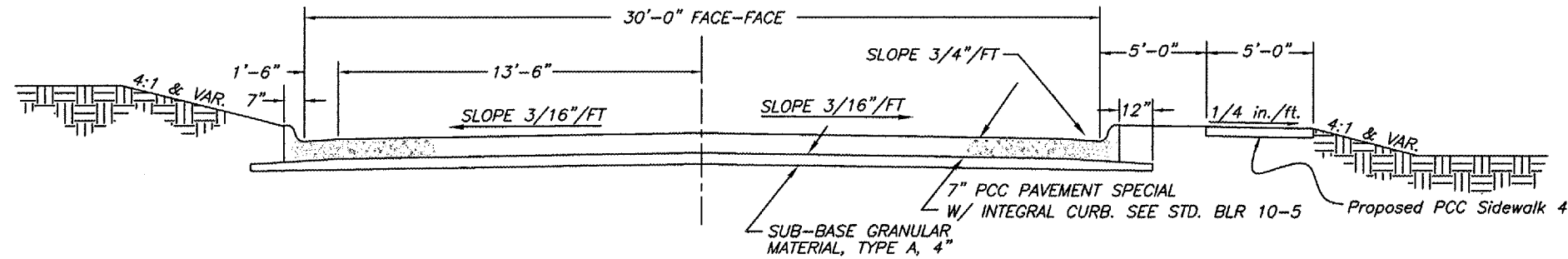

**TYPICAL ROADWAY SECTION**  
NO SCALE

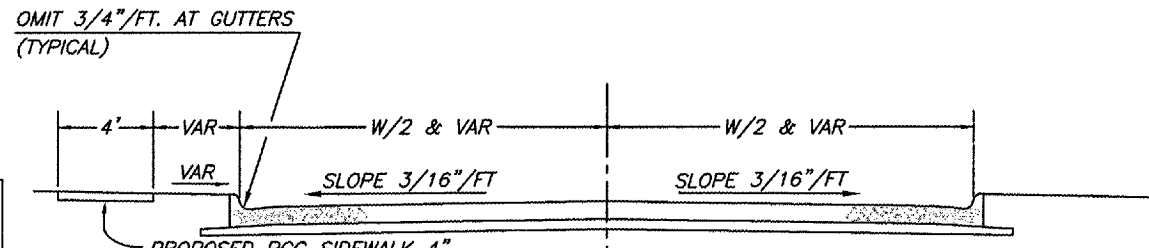

**SIDE STREET TYPICAL SECTION**  
NO SCALE

TO BE USED AT SIDE STREETS AND MAIN PARK ENTRANCE

LOCATION	WIDTH
LINCOLN ST.	28'
W. PARK ENTRANCE	35'
ADAMS ST.	20'
MADISON ST.	28'
VAN BUREN ST.	20'

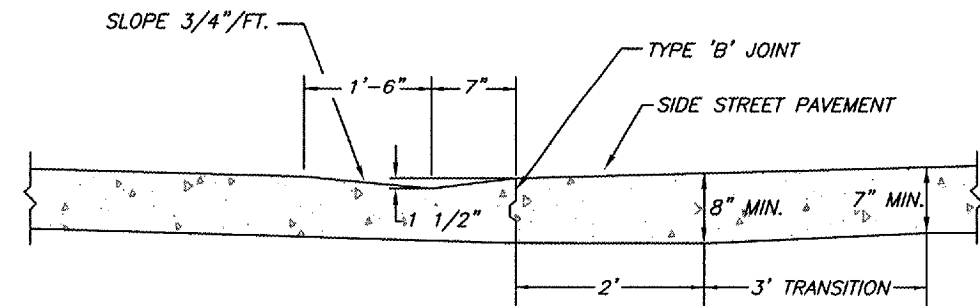

**DEPRESSED CURB**  
NO SCALE

TO BE USED ADJACENT TO CITY STREETS & MAIN PARK ENTRANCE  
 FOR JOINT 'B' DETAILS, SEE STANDARD BLR 10-5

**LEGEND**

- EXISTING UTILITY POLE
- EXISTING CULVERT TO BE REMOVED
- PROPOSED STORM SEWER
- W- PROPOSED WATERMAIN
- W— EXISTING WATERMAIN
- ⊕ EXISTING HYDRANT
- — — CONSTRUCTION LIMITS
- × × × EXISTING FENCE
- ) — EXISTING SANITARY SEWER
- EXISTING SANITARY SEWER MANHOLE
- ) — PROPOSED SANITARY SEWER
- ⊗ PROPOSED SANITARY SEWER MANHOLE
- ▭ EXISTING MAILBOX TO BE MOVED
- ▨ PROPOSED DEPRESSED CURB
- ▩ EXISTING SIDEWALK TO BE REMOVED
- ☀ EXISTING TREE TO REMAIN
- ☀ EXISTING TREE TO BE REMOVED

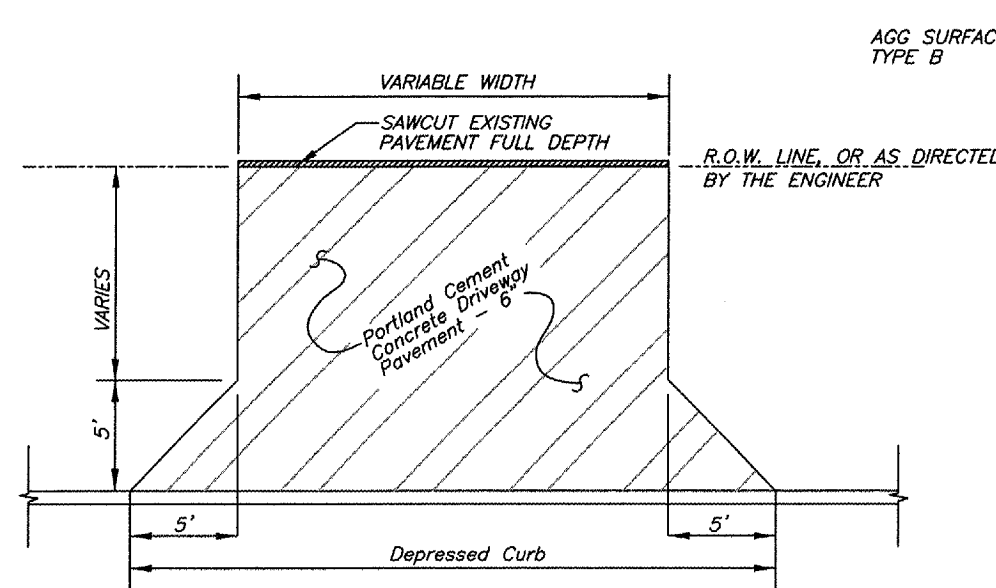

**EXISTING PERMANENT PAVEMENT ENTRANCE DETAIL**  
NOT TO SCALE

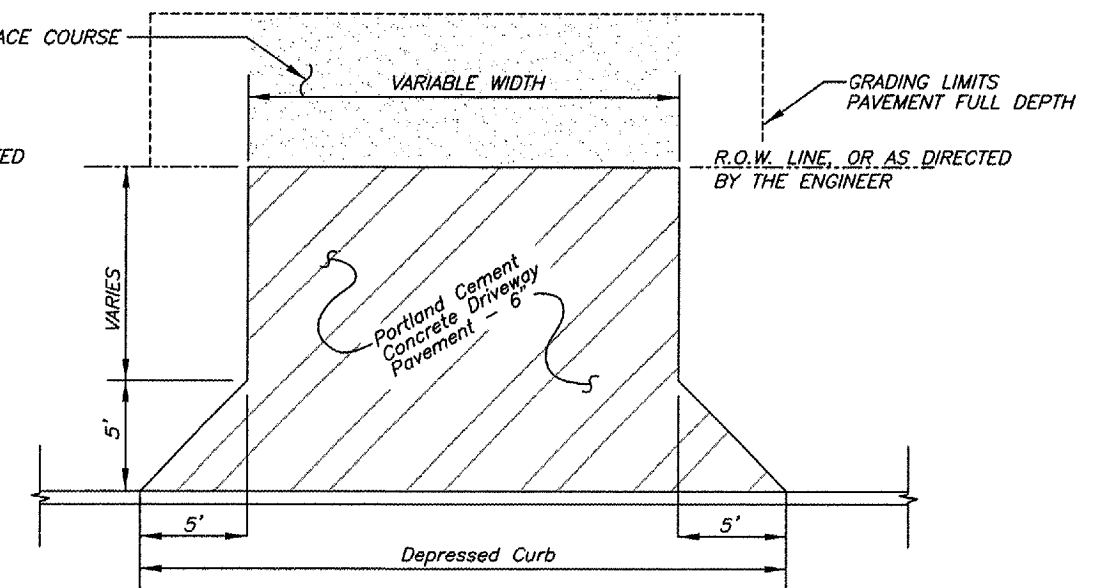

**EXISTING GRAVEL ENTRANCE DETAIL**  
NOT TO SCALE

ROUTE	SECTION	COUNTY	TOTAL SHEETS	SHEET NO.
9477	05-00051-00-RP	FRANKLIN	23	3
CITY OF WEST FRANKFORT		CLEVELAND STREET		

CONTRACT NO. 99234

**SUMMARY OF QUANTITIES**

J000

CODE NO.	PAY ITEM	UNIT	QUANTITY
20100110	TREE REMOVAL (6 TO 15 UNITS DIAMETER)	UNIT	135
20100210	TREE REMOVAL (OVER 15 UNITS DIAMETER)	UNIT	118
20200100	EARTH EXCAVATION	CU YD	3,150
20800150	TRENCH BACKFILL	CU YD	282.1
*25000900	SEEDING, CLASS 1 (SPECIAL)	ACRE	0.6
25100630	EROSION CONTROL BLANKET	SQ YD	2,910
28000250	TEMPORARY EROSION CONTROL SEEDING	POUND	150
28000300	TEMPORARY DITCH CHECKS	EACH	1
28000400	PERIMETER EROSION BARRIER	FOOT	700
28000500	INLET AND PIPE PROTECTION	EACH	30
31100100	SUB-BASE GRANULAR MATERIAL, TYPE A	TON	1,200
40200800	AGGREGATE SURFACE COURSE, TYPE B	TON	300
42300200	PORTLAND CEMENT CONCRETE DRIVEWAY PAVEMENT, 6 INCH	SQ YD	235.7
42400100	PORTLAND CEMENT CONCRETE SIDEWALK 4 INCH	SQ FT	1,124
44000200	DRIVEWAY PAVEMENT REMOVAL	SQ YD	114.8
44000500	COMBINATION CURB AND GUTTER REMOVAL	FOOT	345
44000600	SIDEWALK REMOVAL	SQ FT	908
50300225	CONCRETE STRUCTURES	CU YD	5
50800105	REINFORCEMENT BARS	POUND	20
550A0050	STORM SEWERS, CLASS A, TYPE 1 12"	FOOT	488
550A0070	STORM SEWERS, CLASS A, TYPE 1 15"	FOOT	138
550A0110	STORM SEWERS, CLASS A, TYPE 1 21"	FOOT	347
550A0120	STORM SEWERS, CLASS A, TYPE 1 24"	FOOT	327
550A0140	STORM SEWERS, CLASS A, TYPE 1 30"	FOOT	103
550A0160	STORM SEWERS, CLASS A, TYPE 1 36"	FOOT	65
55100400	STORM SEWER REMOVAL 10"	FOOT	10
55100500	STORM SEWER REMOVAL 12"	FOOT	402
55100900	STORM SEWER REMOVAL 18"	FOOT	192
55101200	STORM SEWER REMOVAL 24"	FOOT	205
55101400	STORM SEWER REMOVAL 30"	FOOT	12
Δ 56100600	WATER MAIN 6"	FOOT	920
Δ*56104900	WATER VALVES 6"	EACH	2
Δ*56108710	TAPPING VALVES AND SLEEVES 4"	EACH	1
Δ*56108800	TAPPING VALVES AND SLEEVES 6"	EACH	2
Δ 56200200	WATER SERVICE LINE 3/4"	FOOT	600
*60223100	MANHOLE, TYPE A, SPECIAL, 5'-DIAMETER, TYPE 1 FRAME, CLOSED LID	EACH	2
*60242900	INLET, SPECIAL, TYPE 1	EACH	4
*60243300	INLET, SPECIAL, TYPE 3, 5'	EACH	24
60255800	MANHOLES TO BE ADJUSTED WITH NEW TYPE 1 FRAME, CLOSED LID	EACH	4
60500060	REMOVING INLETS	EACH	7
67000400	ENGINEER'S FIELD OFFICE, TYPE A	CAL MO	12
67100100	MOBILIZATION	L SUM	1
Δ 72000100	SIGN PANEL - TYPE 1	SQ FT	66.75
Δ 72800100	TELESCOPING STEEL SIGN SUPPORT	FOOT	170

J000

CODE NO.	PAY ITEM	UNIT	QUANTITY
Δ 78001110	PAINT PAVEMENT MARKING - LINE 4"	FOOT	320
Δ 78001130	PAINT PAVEMENT MARKING - LINE 6"	FOOT	199
Δ 78001150	PAINT PAVEMENT MARKING - LINE 12"	FOOT	150
*LR420125	PORTLAND CEMENT CONCRETE PAVEMENT 7" (SPECIAL) WITH INTEGRAL CURB	SQ YD	4,875
*Z0075300	TIE BARS	EACH	22
Δ*XX005889	12" PVC WATERMAIN ENCASEMENT	FOOT	60
Δ*XX005890	DETECTION WIRE	FOOT	920
Δ*XX005891	WATER SERVICE RECONNECTIONS	EACH	11
*XX005893	REINFORCED CONCRETE PIPE TEE, 21" WITH 15" RISER	EACH	1
42400800	DETECTABLE WARNING	SQ FT	72

Δ SPECIALTY ITEMS \* SEE SPECIAL PROVISIONS

**TEMPORARY BENCHMARKS**

NUMBER	LOCATION	ELEVATION
1	McClellan & Cleveland Intersection, F.H.	402.18
2	Cleveland & Lincoln Intersection, F.H.	407.48
3	Cleveland & Madison Intersection, RR Spike in U.P.	402.59
4	Cleveland & Van Buren Intersection, RR Spike in U.P.	402.61

**SIGNING SCHEDULE**

APPROXIMATE LOCATION	TYPE	NO.	SIGN SQ. FT.	POSTS FOOT
4+64, 17' RT.	STOP	R1-1 (30")	6.25	11.5
4+74, 32' LT.	STOP	R1-1 (30")	6.25	11.5
4+26, 17' LT.	STOP	R1-1 (30")	6.25	11.5
5+81, 25' RT.	STOP	R1-1 (30")	6.25	11.5
6+25, 17' RT.	NO PARKING THIS SIDE	R7-(12X18)	1.50	9.5
6+90, 18' LT.	NO PARKING THIS SIDE	R7-(12X18)	1.50	9.5
8+02, 28' LT.	STOP	R1-1 (30")	6.25	11.5
9+00, 18' RT.	NO PARKING THIS SIDE	R7-(12X18)	1.50	9.5
10+50, 18' LT.	NO PARKING THIS SIDE	R7-(12X18)	1.50	9.5
10+70, 25' RT.	STOP	R1-1 (30")	6.25	11.5
11+30, 39' LT.	STOP	R1-1 (30")	6.25	11.5
12+40, 17' RT.	NO PARKING THIS SIDE	R7-(12X18)	1.50	9.5
14+25, 18' LT.	NO PARKING THIS SIDE	R7-(12X18)	1.50	9.5
14+94, 30' LT.	STOP	R1-1 (30")	6.25	11.5
15+23, 25' RT.	STOP	R1-1 (30")	6.25	11.5
15+75, 17' RT.	NO PARKING THIS SIDE	R7-(12X18)	1.50	9.5

TOTAL SIGN AND POST QUANTITIES 66.75 170

### DRIVEWAY PAVEMENT SCHEDULE

LOCATION	EXIST. SURFACE	DRIVEWAY PAVT. REMOVAL			PCC DRIVEWAY PAVT. 6"		
		LENGTH	WIDTH	SQ. YD.	LENGTH	WIDTH	SQ. YD.
5+96 LT	CONC.	14'	8'	12.4	9.4'	12'	15.3
7+14 LT	AGG.	-	-	-	5.3'	12'	9.8
9+15 LT	VAR.	8'	12'	10.7	14.5'	12'	22.1
9+93 LT	CONC.	22'	9'	22.0	14.4'	12'	22.1
10+57 RT	AGG.	-	-	-	9.4'	20'	23.7
11+74 RT	AGG.	-	-	-	9.4'	18'	21.6
12+68 LT	CONC.	21'	20'	46.7	14.4'	19.5'	35.5
13+22 LT	NONE	-	-	-	8.6'	12'	14.2
15+07 RT	AGG.	-	-	-	14.4'	24'	41.2
16+59 LT	CONC.	9'	23'	23.0	10.3'	12'	30.2

TOTAL DRIVEWAY PAVEMENT REMOVAL AND REPLACEMENT 114.8 235.7

### PCC PAVEMENT 7" SPECIAL W/IC

LOCATION	AREA (SQ. YD.)
CLEVELAND ST. EXISTING TRANSITION 4+50 TO 6+00	470
LINCOLN STREET INTERSECTION	110
CLEVELAND STREET MAINLINE 6+00 TO 17+31	3917
WEST PARK ENTRANCE	95
ADAMS STREET ENTRANCE	64
MADISON STREET INTERSECTION	156
VAN BUREN STREET INTERSECTION	63

TOTAL PCC PAVEMENT 7" SPECIAL W/IC 4875

### PAINT PAVEMENT MARKING LINE (FEET)

LOCATION	CROSSWALK	STOP BAR	SKIP DASH CL.
	6" WHITE	12" WHITE	4" YELLOW
CENTERLINE 4+50 TO 17+31	-	-	320
STA. 4+64 RT	-	12	-
STA. 4+68 & 4+74	65	-	-
STA. 4+74 TO 4+89, 25'LT	-	15	-
STA. 4+74 TO 5+09, 18'RT & 24'RT	69	-	-
STA. 5+08 & 5+14	65	-	-
STA. 5+18 LT	-	18	-
STA. 5+57 TO 5+77, 25'RT	-	20	-
STA. 8+06 TO 8+18, 26'LT	-	12	-
STA. 11+28 TO 11+48, 27'LT	-	20	-
STA. 14+80 RT	-	15	-
STA. 14+94 TO 15+04, 27'LT	-	10	-
STA. 15+07 TO 15+20, 25'RT	-	13	-
STA. 15+37 LT	-	15	-

TOTAL PAVEMENT MARKING 199 150 320

### SIDEWALK SCHEDULE

LOCATION	WIDTH	LENGTH	AREA (SQ. FT.)
4+50 TO 5+31 RT	4'	81'	324
4+72 RT	4'	6'	24
5+11 RT	4'	6'	24
LINCOLN ST. (WEST)	4'	28'	112
LINCOLN ST. (EAST)	4'	18'	72
STA. 5+80 TO 6+12 RT.	4'	35'	140
ADAMS ST. (WEST)	4'	18'	72
MADISON ST. (WEST)	4'	28'	112
STA. 13+60 LT	4'	18'	72
VAN BUREN ST. (WEST)	4'	26'	104
STA. 15+33 RT	4'	17'	68

TOTAL PC SIDEWALK 4" 1124

### STORM SEWER REMOVAL SCHEDULE

LOCATION NUMBER	STATION	OFFSET (FEET)	LENGTH (FEET)					TRENCH BACKFILL CU. YDS.
			10"	12"	18"	24"	30"	
1	5+90 TO 6+29 LT	13		39				-
2	6+99 TO 7+15 LT	13	10					-
3	7+15 TO 7+25 LT	13		16				-
4	7+93 TO 8+01 LT	17		8				-
5	8+01 LT	13 TO 21		8				-
6	8+01 TO 8+35 LT	13		34				-
7	9+05 TO 9+27 LT	13		22				-
8	9+28 TO 9+76 LT	13		48				-
9	9+77 TO 10+05 LT	13		28				-
10	10+42 TO 10+71 RT	17		29				-
11	11+04 TO 11+29 LT	14 TO 27			28			-
12	11+30 LT	28 TO 49		21				-
13	11+30 TO 11+72 LT	16 TO 27			42			-
14	11+59 TO 11+88 RT	15		29				-
15	11+73 TO 11+90 LT	16			17			-
16	12+55 TO 12+80 LT	16			25			-
17	13+24 TO 13+80 LT	15			56			-
18	14+13 TO 14+92 LT	16				79		-
19	14+52 TO 15+52 RT	17		100				-
20	14+95 LT	16 TO 24			8			-
21	14+95 LT	24 TO 44		20				-
22	14+96 TO 15+20 LT	15				24		-
23	15+22 LT	16 TO 32				16		-
24	15+23 TO 15+35 LT	15					12	-
25	15+86 TO 16+88 LT	15				102		22.6

TOTAL STORM SEWER REMOVAL 10 402 192 205 12 22.6

ROUTE	SECTION	COUNTY	TOTAL SHEETS	SHEET NO.
9477	05-00051-00-RP	FRANKLIN	23	4
CITY OF WEST FRANKFORT		CLEVELAND STREET		

CONTRACT NO. 99234

### SIDEWALK REMOVAL SCHEDULE

LOCATION	WIDTH	LENGTH	SQ. FT.
STA. 4+50 TO 5+29 RT.	4'	79'	316
LINCOLN ST. (WEST)	4'	28'	112
LINCOLN ST. (EAST)	4'	21'	84
ADAMS ST. (WEST)	4'	14'	56
MADISON ST. (WEST)	4'	33'	132
STA. 12+31 RT.	2'	12'	24
STA. 13+70 LT.	4'	6'	24
STA. 14+56 LT.	8'	4'	32
VAN BUREN ST. (WEST)	4'	15'	60
STA. 15+33 RT.	4'	17'	68

TOTAL SIDEWALK REMOVAL 908

### COMBINATION CURB AND GUTTER REMOVAL SCHEDULE

LOCATION	LENGTH (FOOT)
NW CORNER LINCOLN STREET	45
NE CORNER LINCOLN STREET	40
SOUTH SIDE LINCOLN STREET	84
STA. 5+25 TO 5+89 LT	64
NW CORNER MADISON STREET	60
NE CORNER MADISON STREET	52

TOTAL CURB & GUTTER REMOVAL 345

### MANHOLES TO BE ADJUSTED

WITH NEW TYPE 1 FRAME AND CLOSED LID

LOCATION	LID ELEVATION		ADJUSTMENT (FOOT)
	EXIST.	PROPOSED	
0.5' RT 6+05	403.51	403.65	+0.14
1.5' RT 8+94.3	402.52	401.75	-0.77
1.0' RT 12+07.5	402.45	400.82	-1.63
1.5' RT 15+05	400.65	400.66	+0.01

TOTAL MANHOLES TO BE ADJUSTED 4 EACH

### DRAINAGE STRUCTURE SCHEDULE

	OFFSET	SIDE	STATION	STRUCTURE TYPE	CASTING (TOP ELEV.)	FLOWLINE (ELEV.)
1	16.83	LT	5+40	INLET SPEC., TYPE 3, 5'	404.45	401.45
2	16.83	RT	6+75	INLET SPEC., TYPE 3, 5'	403.16	400.16
3	16.83	LT	6+75	INLET SPEC., TYPE 3, 5'	403.16	399.86
4	17.08	LT	7+84	INLET SPEC., TYPE 3, 5'	402.31	398.56
4A	17.08	LT	8+02	R.C. PIPE TEE, 21" WITH 15" RISER	-	398.51
5	31	LT	8+02	INLET SPEC., TYPE 1	402.63	399.83
6	31	LT	8+32	INLET SPEC., TYPE 1	402.63	400.13
7	16.83	RT	8+61	INLET SPEC., TYPE 3, 5'	402.07	399.07
8	17.08	LT	8+61	INLET SPEC., TYPE 3, 5'	402.07	398.32
9	17.08	LT	9+46	INLET SPEC., TYPE 3, 5'	401.82	398.07
10	16.83	RT	10+31	INLET SPEC., TYPE 3, 5'	401.56	398.56
11	17.08	LT	10+31	INLET SPEC., TYPE 3, 5'	401.56	397.81
12	17.08	LT	11+00	INLET SPEC., TYPE 3, 5'	401.36	397.53
13	43	LT	11+31.25	INLET SPEC., TYPE 3, 5'	402.12	399.12
14	43	LT	11+62.75	INLET SPEC., TYPE 3, 5'	402.12	398.82
15	17.08	LT	11+63	MANHOLE, TYPE A, 5'	400.84	397.29
17	17.08	LT	12+11	INLET SPEC., TYPE 3, 5'	401.02	397.11
18	18.25	RT	12+31	INLET SPEC., TYPE 3, 5'	400.96	397.96
19	17.08	LT	13+02	INLET SPEC., TYPE 3, 5'	400.75	396.84
20	16.83	RT	13+71	INLET SPEC., TYPE 3, 5'	400.56	397.56
21	17.08	LT	13+71	INLET SPEC., TYPE 3, 5'	400.56	396.56
22	16.83	RT	13+92	INLET SPEC., TYPE 3, 5'	400.54	397.54
23	17.08	LT	13+92	INLET SPEC., TYPE 3, 5'	400.54	396.47
24	16.83	RT	14+71	INLET SPEC., TYPE 3, 5'	400.74	397.74
25	17.08	LT	14+71	INLET SPEC., TYPE 3, 5'	400.74	396.13
26	44	LT	14+95	CONCRETE COLLAR	-	-
27	33	LT	14+94.5	INLET SPEC., TYPE 1	402.17	399.67
28	33	LT	15+19.5	INLET SPEC., TYPE 1	402.17	399.37
29	17.08	LT	15+20	MANHOLE, TYPE A, 5'	400.63	395.98
30	17.37	LT	15+40	INLET SPEC., TYPE 3, 5'	401.02	395.92
31	16.83	RT	16+33	INLET SPEC., TYPE 3, 5'	401.39	398.39
32	17.67	LT	16+33	INLET SPEC., TYPE 3, 5'	401.39	395.64

### INLET AND CONCRETE REMOVAL

LOCATION	ITEM	APPROXIMATE DIMENSIONS	REMOVING INLETS
9+28, 13'LT	INLET	1.6' X 1.5' X 1.5' (INSIDE DIMENSION)	1
9+76, 13'LT	INLET	2.3' X 1.6' X 1.7' (INSIDE DIMENSION)	1
11+30, 27'LT	INLET	2' DIAMETER X 2.5' (INSIDE DIMENSION)	1
11+72, 16'LT	INLET	2' DIAMETER X 2.5' (INSIDE DIMENSION)	1
14+94, 15'LT	INLET	2.8' X 4.6' X 3.7' (INSIDE DIMENSION)	1
14+95, 24'LT	INLET	1.3' DIAMETER X 1.0' (INSIDE DIM.)	1
15+22, 15'LT	INLET	2.0' X 3.0' X 3.2' (INSIDE DIMENSION)	1

TOTALS FOR INLET AND CONCRETE REMOVAL

7

### STORM SEWER SCHEDULE

POINT TO POINT	CLASS A, TYPE 1 (FOOT)						% GRADE	TR. BACKFILL CU. YDS.
	12"	15"	21"	24"	30"	36"		
1-3	130						1.22	11.0
2-3	31						0.97	2.3
3-4		104					1.25	13.8
4-4A			12				0.33	1.9
6-5	28						1.07	0.8
5-4A		12					8.92	0.3
4A-8			53				0.33	7.3
7-8	31						0.97	2.3
8-9			80				0.31	10.3
9-11			80				0.32	10.3
10-11	31						0.97	2.0
11-12			64				0.44	8.6
12-15			58				0.41	9.0
13-14	29						1.03	2.2
14-15		22					5.59	2.9
15-17			43				0.42	6.0
17-18	37						0.97	2.8
17-19			86				0.31	11.2
19-21			64				0.44	8.8
20-21	31						0.97	2.3
21-23			16				0.56	2.4
22-23	31						0.97	2.3
23-25			74				0.46	14.3
24-25	31						0.97	2.3
25-29			44				0.34	12.0
26-27	10						-	0.2
27-28	22						1.36	0.7
28-29	15						13.27	1.4
29-30				15			0.40	4.2
30-32				88			0.32	28.9
31-32	31						0.97	2.3
32-STUB					65		0.22	35.9
TOTALS	488	138	347	327	103	65		222.9

### WATERMAIN TRENCH BACKFILL SCHEDULE

LOCATION	OFFSET	PIPE	TR. BACKFILL CU. YDS.
STA. 10+47 TO 10+67	23'RT	6" WATERMAIN	5.4
STA. 11+29	17.6'RT TO 5'LT	6" WATERMAIN	6.8
STA. 11+29	5'LT TO 33'LT	12" PVC ENCASEMENT	10.1
STA. 11+29 TO 11+60	33'LT	6" WATERMAIN	9.3
STA. 11+65 TO 11+83	23'RT	6" WATERMAIN	5.0

TOTAL TRENCH BACKFILL FOR WATERMAINS

36.6

### TREE REMOVAL SCHEDULE

LOCATION	OFFSET	INCH DIAMETER	
		6"-15"	OVER 15"
7+47	21'LT	15	-
8+51	21'RT	11	-
8+70	23'RT	11	-
9+15	23'RT	11	-
9+18	23'RT	15	-
9+43	23'RT	8	-
9+48	23'RT	15	-
9+57	26'RT	11	-
9+60	23'RT	8	-
9+72	23'RT	8	-
10+10	20'RT	-	19
10+12	26'RT	-	19
11+04	20'RT	-	34
11+49	22'RT	8	-
11+57	22'RT	8	-
11+69	35'LT	6	-
12+00	29'RT	-	19
12+10	26'RT	-	27

TOTAL TREE REMOVAL (UNITS)

135 118

ROUTE	SECTION	COUNTY	TOTAL SHEETS	SHEET NO.
9477	05-00051-00-RP	FRANKLIN	23	5
CITY OF WEST FRANKFORT		CLEVELAND STREET		
CONTRACT NO. 99234				

## STORM WATER POLLUTION PREVENTION PLAN

The following Plan is established and incorporated in the project to direct the Contractor in the placement of temporary erosion control systems and to provide a storm water pollution prevention plan for compliance under NPDES.

The purpose of this plan is to minimize erosion within the construction site and to limit sediments leaving the construction site by utilizing proper temporary erosion control systems and providing ground cover within a reasonable amount of time.

Certain erosion control facilities shall be installed by the Contractor at the beginning of construction. Other items shall be installed as directed by the Engineer on a case by case situation depending on the Contractor's sequence of activities, time of year and expected weather conditions.

The Contractor shall construct permanent erosion control systems and seeding within a time frame specified herein and as directed by the Engineer, therefore minimizing the amount of area susceptible to erosion and reducing the amount of temporary seeding. The engineer will determine if any temporary erosion control systems shown in the plans can be deleted and if any additional temporary erosion control systems, which are not included in the plans, shall be added. The contractor shall perform all work as directed by the Engineer and as shown in STANDARD 280001.

Section 280, Temporary Erosion Control, of the Standard Specifications additionally supplements this plan.

### DESCRIPTION OF CONSTRUCTION ACTIVITIES

1. Temporary ditch checks shall be located at every 1.5 feet of fall/rise in ditch grade.

### INTENDED SEQUENCE OF MAJOR CONSTRUCTION ACTIVITIES

1. Isolated tree removal. Trees to remain will be protected against damage.
2. Excavation and grading.
3. Storm sewers and drainage structures.
4. Placement of Aggregate Base Course.
5. Placement on PCC Pavement.
6. Seeding and permanent erosion control systems.

ROUTE	SECTION	COUNTY	TOTAL SHEETS	SHEET NO.
9477	05-00051-00-RP	FRANKLIN	23	6
CITY OF WEST FRANKFORT		CLEVELAND STREET		

CONTRACT NO. 99234

### AREA OF CONSTRUCTION SITE

1. The total area of the construction site is estimated to be 1.7 Acres of which approximately 1.7 Acres will be disturbed.

### OTHER REPORTS, STUDIES AND PLANS WHICH AID IN THE DEVELOPMENT OF THE SWPPP AS REFERENCED DOCUMENTS.

1. Information of the terrain was obtained from topographic maps.
2. Project plan documents, specifications and special provisions and plan drawings indicating the drainage patterns and location of existing drainage features were utilized in the preparation of the proposed placement of temporary erosion control systems.

### DRAINAGE TRIBUTARIES AND SENSITIVE AREAS RECEIVING RUNOFF

1. Proposed storm sewer outlets are tributary to existing roadside ditches. No new discharge points will be constructed.

### CONTROLS - EROSION CONTROLS AND SEDIMENT CONTROLS

1. Existing vegetation will be preserved where attainable and disturbed portions of the site will be stabilized. Stabilization practices will include temporary seeding, permanent seeding, mulching, protection of trees, preservation of mature vegetation and other appropriate measures as directed by the Engineer. Stabilization measures shall be initiated as soon as practical in those areas of the site where construction activities have ceased, but in no case more than 7 days after the construction activity for an area has temporarily or permanently ceased.
2. Areas outside the construction limits shall be protected from construction activities.
3. Dead, diseased or unsuitable vegetation within the site shall be removed as directed by the Engineer.
4. As soon as is reasonable, the temporary erosion control system shall be installed as indicated in the plans or as directed by the engineer.

This plan has been prepared with the intent to comply with the provisions of the NPDES Permit Number ILR10, issued by the Illinois Environmental Protection Agency for storm water discharges from construction site activities.

I certify under penalty of law that this plan was prepared at my direction in accordance with a system that qualified personnel properly gathered and evaluated the information submitted. Based on my inquiry of the person or persons who manage the system, or those persons directly responsible for gathering the information, the information submitted is, to the best of my knowledge and belief, true, accurate and complete. I am aware that there are significant penalties for submitting false information, including the possibility of fine and imprisonment.

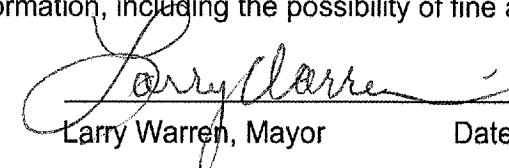
  
Larry Warren, Mayor      Date: July 25, 2005

DESCRIPTION OF STABILIZATION PRACTICES  
DURING CONSTRUCTION

1. During construction, areas outside the construction limits shall be protected.
2. Within the construction limits, areas which may be susceptible to erosion as determined by the Engineer shall remain undisturbed until full scale construction is underway.
3. Earth stockpiles shall be temporary seeded if they are to remain unused for more than 14 days.
4. As soon as construction proceeds, the contractor shall institute the following as directed by the Engineer:
  - A) Place temporary erosion control facilities at locations shown in the plans.
  - B) Temporarily seed erodable bare earth on a weekly basis to minimize the amount of erodable surface area within the contract limits.
  - C) Construct roadside ditches and provide temporary erosion control systems.
  - D) Temporarily divert water around proposed culvert locations.
5. Excavated areas shall be permanently seeded immediately after final grading. If not, they shall be temporarily seeded if no construction in the area is planned for 7 days.
6. All necessary measures shall be taken by the contractor to contain any fuel or pollutant in accordance with EPA water quality regulations. Leaking equipment or supplies shall be immediately repaired or removed from the site.
7. The Resident Engineer shall inspect the project daily during construction activities. Inspection shall also be done weekly and after rains of 0.5 inches or greater or equivalent snowfall and during any winter shutdown period.
8. Sediment collected during the construction by the various temporary erosion control systems shall be disposed of on site on a regular basis as directed by the Resident Engineer. The cost of this maintenance shall be considered incidental to the erosion control system.
9. The temporary erosion control systems shall be removed as directed by the Engineer after use is no longer needed or no longer functioning. The cost of removal shall be included in the unit bid price for various temporary erosion control pay items.

DESCRIPTION OF STRUCTURAL PRACTICES  
AFTER FINAL GRADING

1. Temporary seeding shall be left in place with proper maintenance until permanent erosion control and all proposed turf areas seeded and established.
2. Once permanent erosion control systems as proposed in the plans are functional and established, temporary items shall be removed, cleaned up and disturbed turf areas reseeded.

MAINTENANCE AFTER CONSTRUCTION

1. Construction is complete after FINAL acceptance by I.D.O.T. final inspection. Maintenance up to this date will be by the contractor.

MISCELLANEOUS

1. Temporary ditch checks shall be located at every 1.5 feet of fall/rise in ditch grade.
2. Temporary erosion control seeding shall be applied at the rate of 100 lbs/acre.
3. Straw bales, hay bales, perimeter erosion control barrier and silt fences will not be permitted for temporary or permanent ditch checks. Ditch checks shall be composed of aggregate, silt panels, rolled excelsior, urethane foam geotextile (silt wedges) and/or other material approved by the erosion and sediment control coordinator.
4. All erosion control products furnished shall be specifically recommended by the manufacturer for the use specified in the erosion control plan. Prior to the approval and use of the product, the contractor shall submit to the Engineer a notarized certification by the producer stating the intended use of the product and the physical properties required for this application are met or exceeded. The contractor shall provide manufacturer installation procedures to facilitate the Engineer in construction inspection.
5. All items shall be constructed as shown on STANDARD 280001 and as directed by the Engineer. Maintenance and cleaning of erosion control items shall be considered part of the respective erosion control pay item.

ROUTE	SECTION	COUNTY	TOTAL SHEETS	SHEET NO.
9477	05-00051-00-RP	FRANKLIN	23	7
CITY OF WEST FRANKFORT		CLEVELAND STREET		

**CONTRACT NO. 99234**

# LEGEND

- EXISTING UTILITY POLE
- EXISTING CULVERT TO BE REMOVED
- PROPOSED STORM SEWER
- - - W - - - PROPOSED WATERMAIN
- - - W - - - EXISTING WATERMAIN
- ⊙ EXISTING HYDRANT
- G - EXISTING BURIED GAS LINE
- T - EXISTING BURIED TELEPHONE
- — — CONSTRUCTION LIMITS
- × × × EXISTING FENCE
- ⊂ EXISTING SANITARY SEWER
- EXISTING SANITARY SEWER MANHOLE
- ⊂ EXISTING SANITARY SEWER
- ⊗ PROPOSED SANITARY SEWER MANHOLE
- ▭ EXISTING MAILBOX TO BE MOVED
- ▨ PROPOSED DEPRESSED CURB
- ▩ EXISTING SIDEWALK TO BE REMOVED
- ☼ EXISTING TREE TO REMAIN
- ☼ EXISTING TREE TO BE REMOVED

ROUTE	SECTION	COUNTY	TOTAL SHEETS	SHEET NO.
9477	05-00051-00-RP	FRANKLIN	23	8
CITY OF WEST FRANKFORT		CLEVELAND STREET		

**CONTRACT NO. 99234**  
 RADIUS PT. STA. 5+30, 40' LT  
**RICHARD JEFFERIES**  
 P16, TR1  
 LOT 1

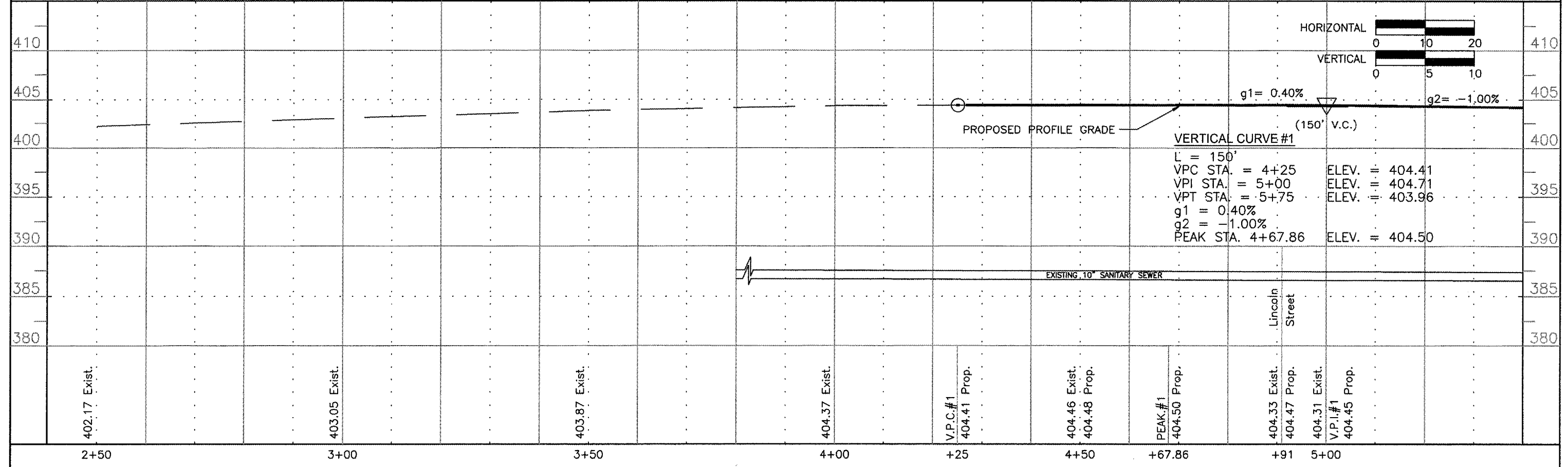
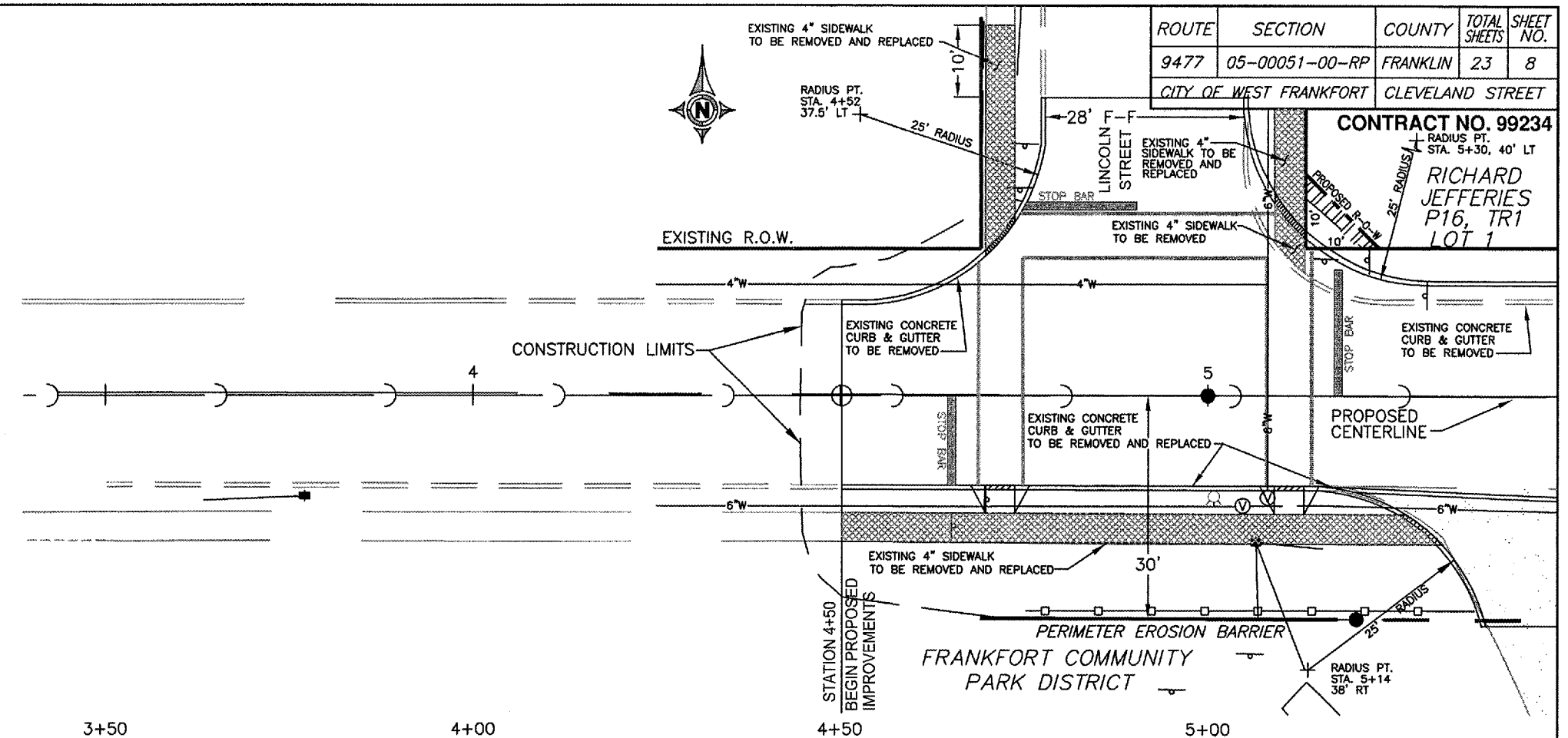



ROUTE	SECTION	COUNTY	TOTAL SHEETS	SHEET NO.
9477	05-00051-00-RP	FRANKLIN	23	9
CITY OF WEST FRANKFORT		CLEVELAND STREET		

CONTRACT NO. 99234

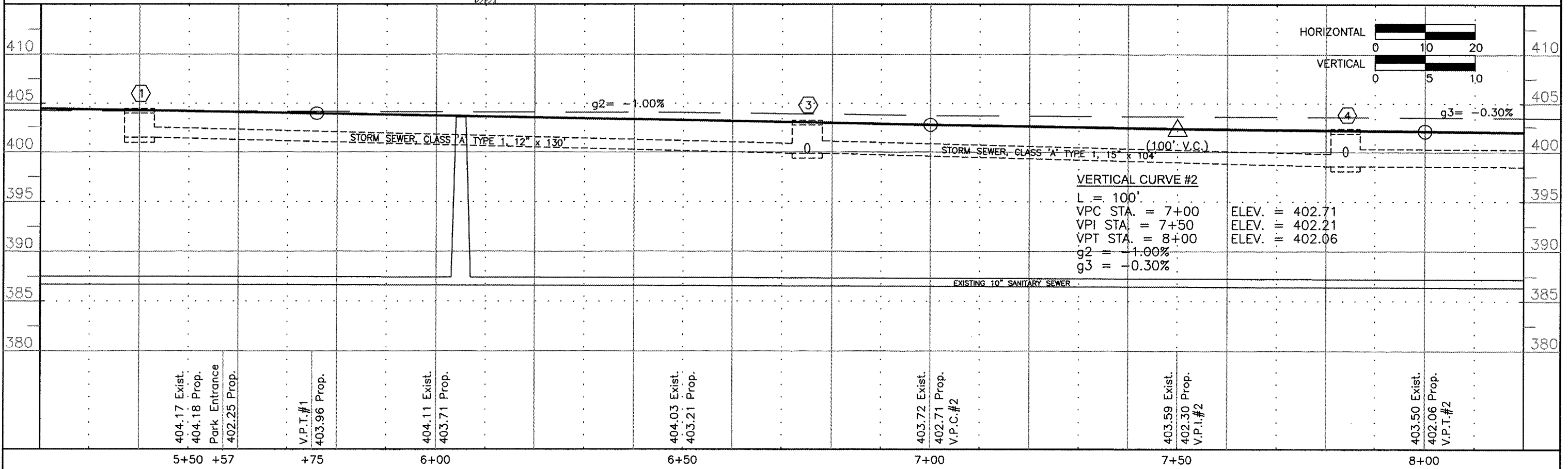
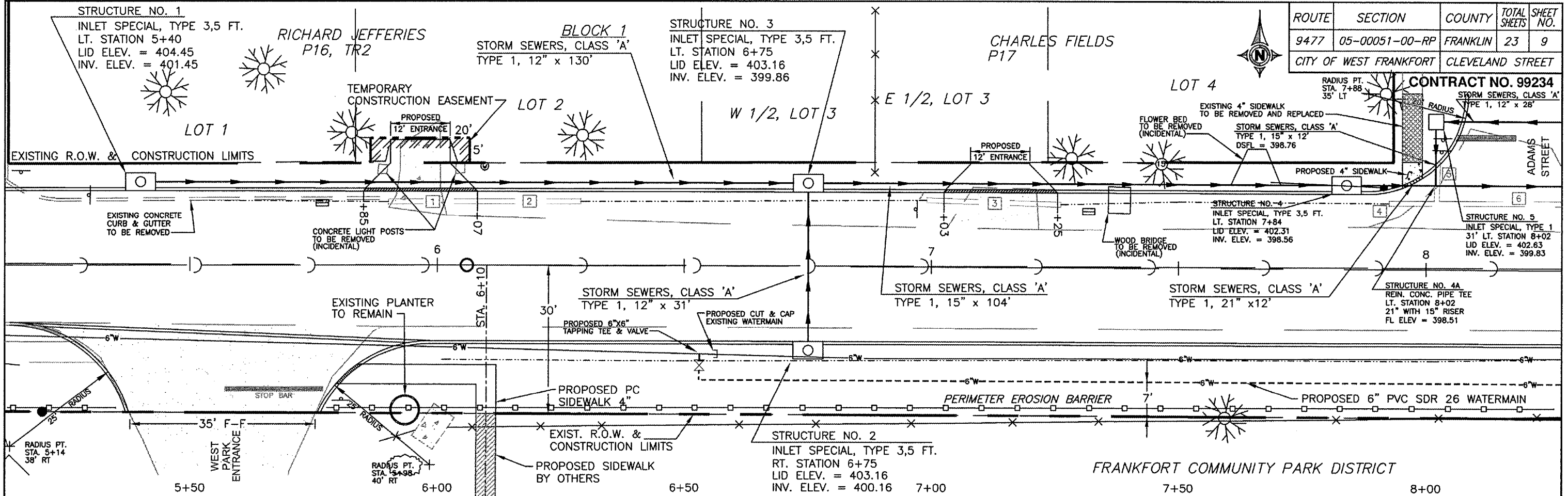

404.17 Exist.	404.18 Prop.	Park Entrance	402.25 Prop.	V.P.T.#1	403.96 Prop.	404.11 Exist.	403.71 Prop.	404.03 Exist.	403.21 Prop.	403.72 Exist.	402.71 Prop.	V.P.C.#2	403.59 Exist.	402.30 Prop.	V.P.I.#2	403.50 Exist.	402.06 Prop.	V.P.T.#2
5+50	+57			+75		6+00		6+50		7+00			7+50			8+00		



ROUTE	SECTION	COUNTY	TOTAL SHEETS	SHEET NO.
9477	05-00051-00-RP	FRANKLIN	23	11
CITY OF WEST FRANKFORT			CLEVELAND STREET	

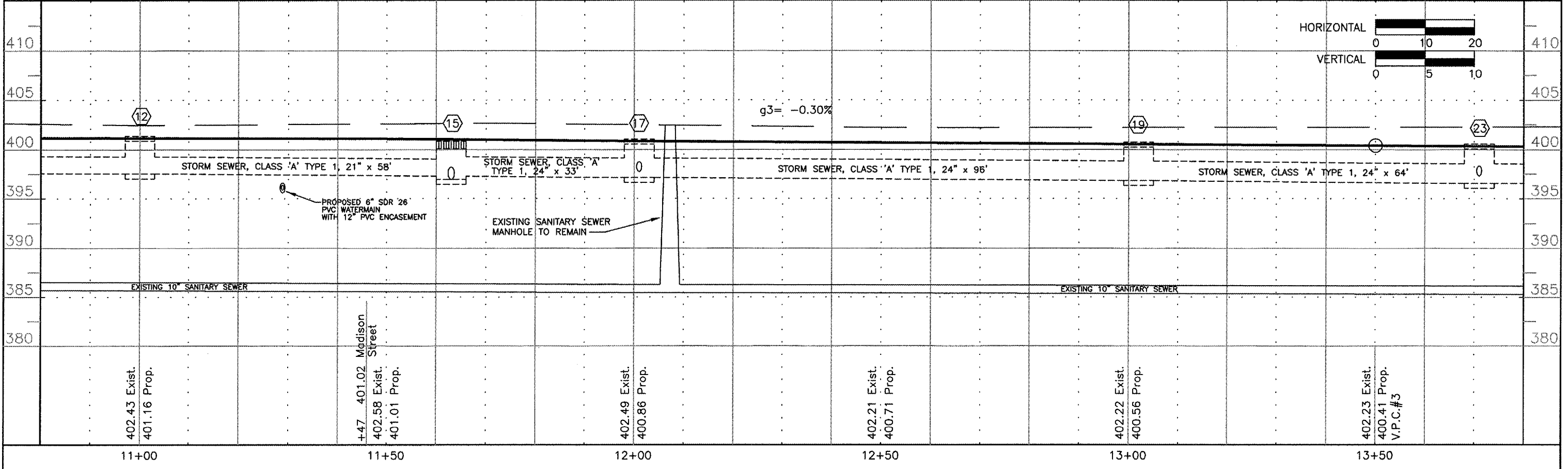
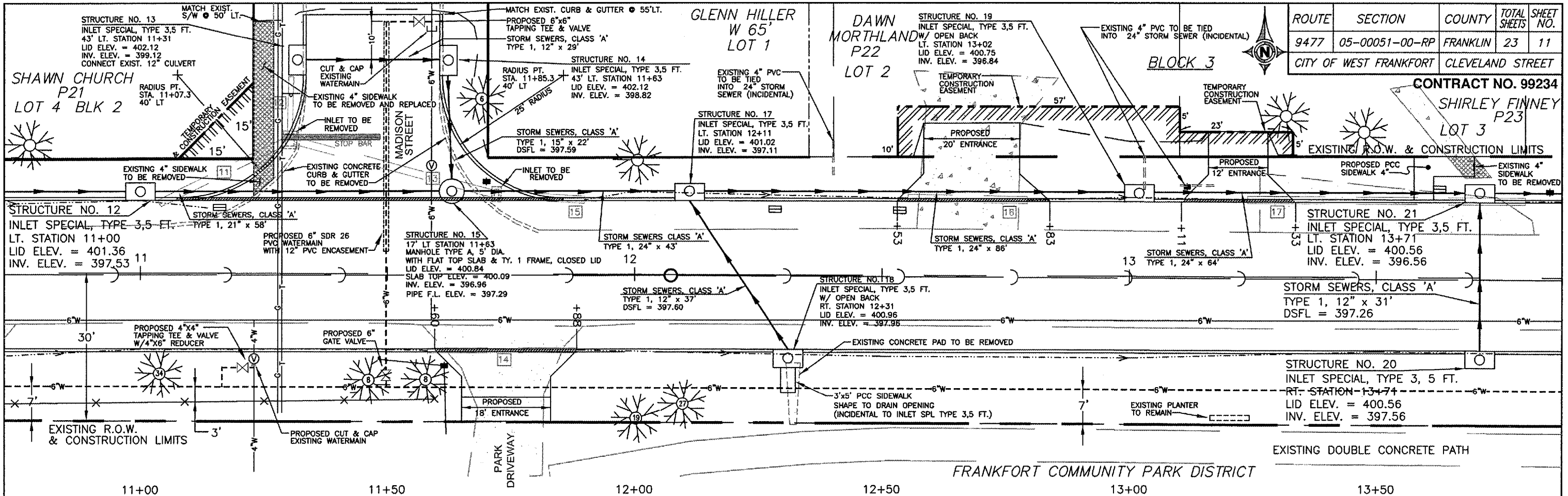

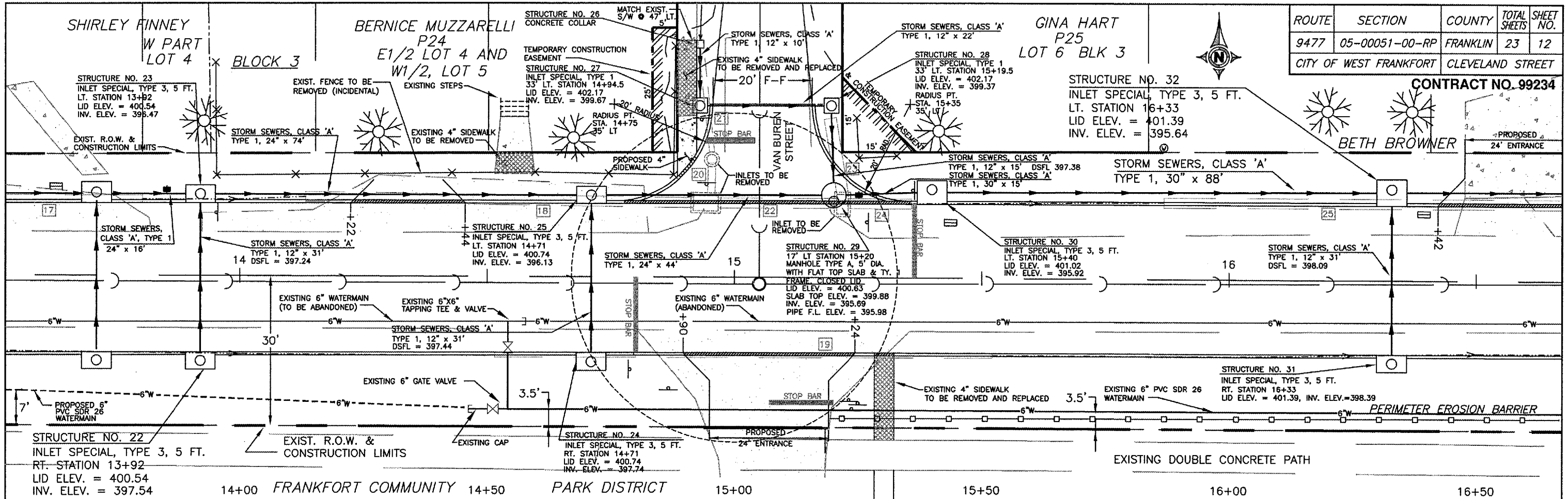

ROUTE	SECTION	COUNTY	TOTAL SHEETS	SHEET NO.
9477	05-00051-00-RP	FRANKLIN	23	12
CITY OF WEST FRANKFORT		CLEVELAND STREET		

CONTRACT NO. 99234

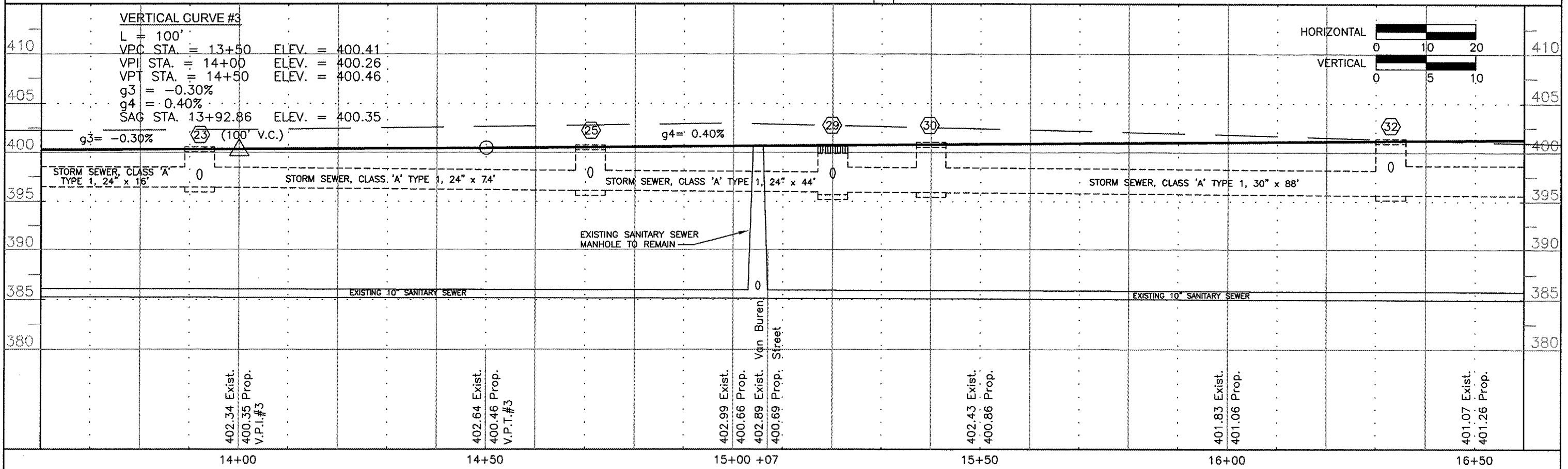

BETH BROWNER

FIRST CHRISTIAN CHURCH



ROUTE	SECTION	COUNTY	TOTAL SHEETS	SHEET NO.
9477	05-00051-00-RP	FRANKLIN	23	13
CITY OF WEST FRANKFORT		CLEVELAND STREET		

CONTRACT NO. 99234

DOROTHY PERRY

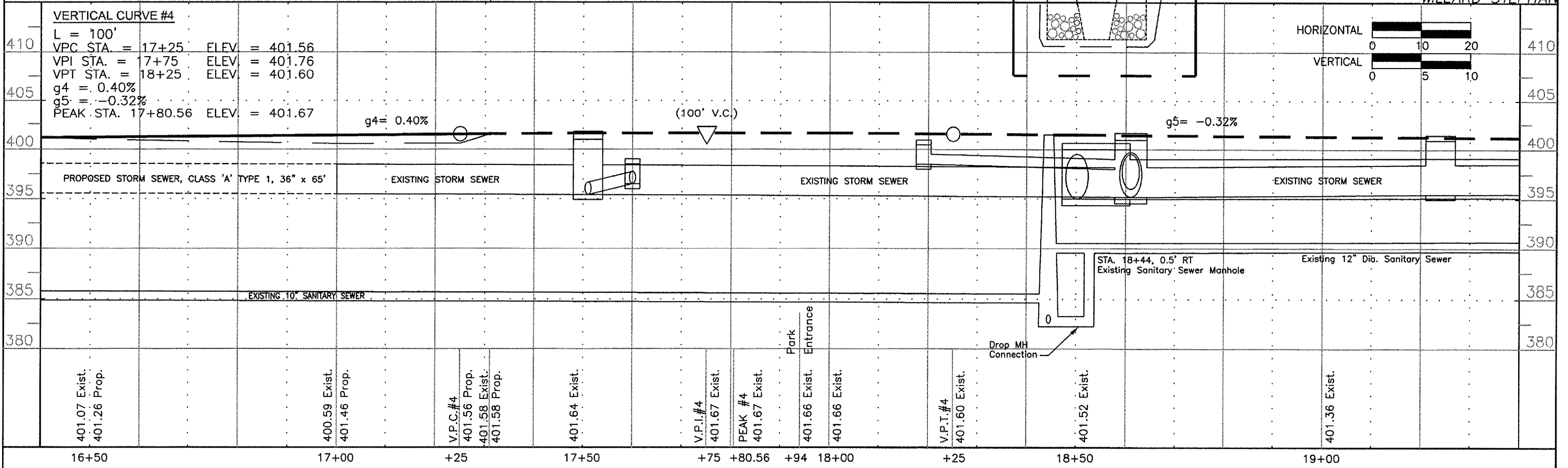
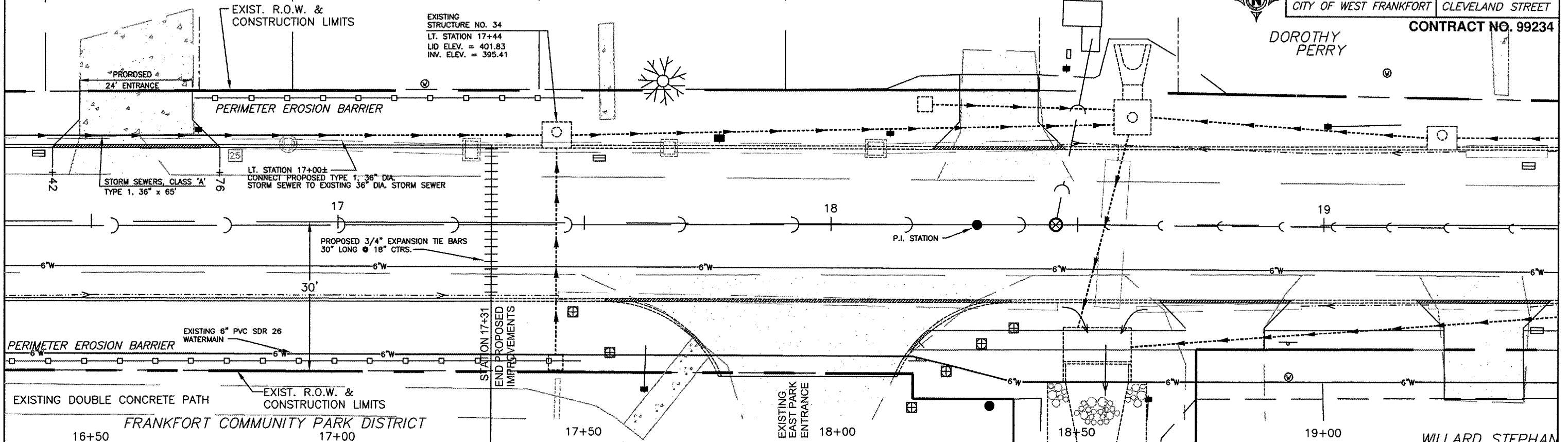

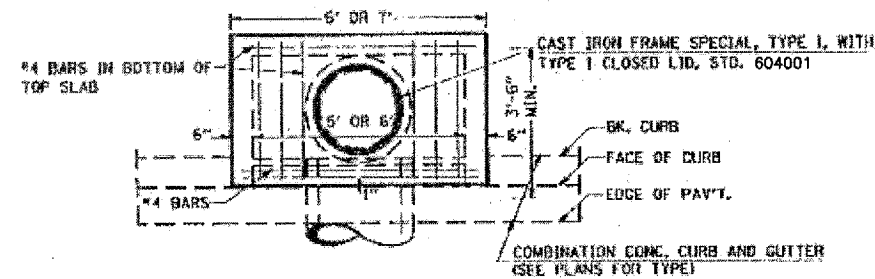

PLAN

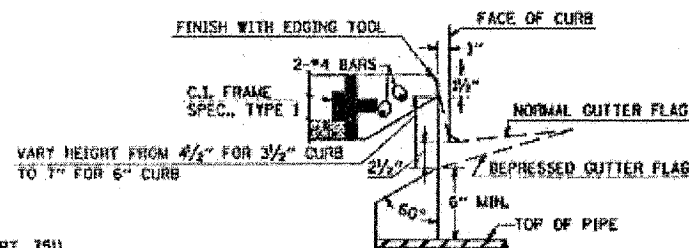

DETAIL AT WEIR

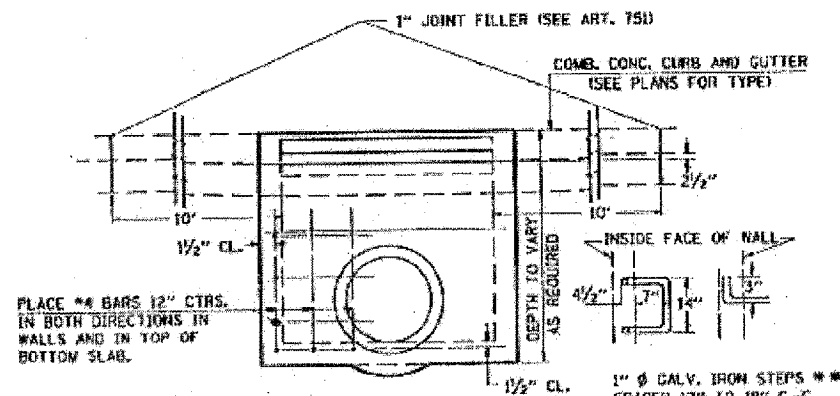

ELEVATION

DESIGN	PIPE DIA.	"D"
A	18" ALESS	2'-6"
B	21" x 24"	3'-0"
C	27" x 30"	3'-7"
D	33" x 36"	4'-2"
E	42"	4'-9"
F	48"	5'-0"
G	54"	6'-1"

NOTES:

CLASS SI CONCRETE SHALL BE USED THROUGHOUT. SET FACE OF INLET 1" BEHIND FACE OF CURB. DEPRESS GUTTER FLOWLINE AT INLET 2 1/2" BELOW NORMAL GUTTER FLOWLINE. CONSTRUCT TRANSITION IN FLOWLINE IN 30 FEET EACH SIDE OF INLET. PIPES TO BE CONNECTED TO INLET AS SHOWN ON STORM SEWER LAYOUT.

INLETS WILL BE PAID FOR AT THE CONTRACT UNIT PRICE EACH FOR INLET, SPECIAL, TYPE 3, 5 FEET OR INLET, SPECIAL, TYPE 3, 6 FEET WHICH PRICE SHALL INCLUDE THE CAST IRON FRAME, SPECIAL, TYPE 1 WITH TYPE 1 CLOSED LID, THE REINFORCEMENT BARS, METAL STEPS AND JOINT FILLER.

\*\*\*THE CALV. IRON STEPS AS DETAILED HEREON ARE TYPICAL. STEPS OF OTHER DESIGN AND MATERIAL THAT WILL CONFORM TO THE MINIMUM REQUIREMENTS OF THE STEPS SHOWN, MAY BE USED WHEN APPROVED BY THE ENGINEER.

INLETS MAY BE PRECAST WHEN APPROVED BY THE ENGINEER.

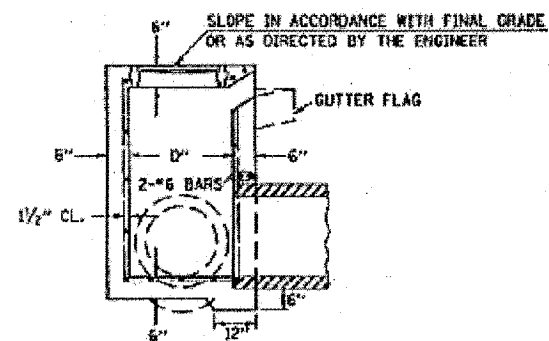

SECTION

DETAIL - INLETS, SPECIAL, TYPE 3, 5'

PIPE DIA.	CLASS SI CONCRETE CU. YD. (EST.)
12"	0.16
15"	0.19
18"	0.21
24"	0.29
30"	0.37
36"	0.44
42"	0.53
48"	0.62
54"	0.71

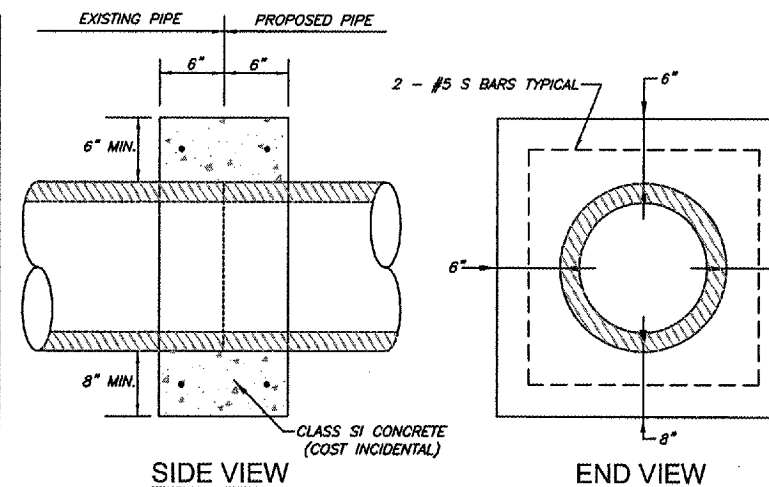

SIDE VIEW

END VIEW

ROUTE	SECTION	COUNTY	TOTAL SHEETS	SHEET NO.
9477	05-00051-00-RP	FRANKLIN	23	14
CITY OF WEST FRANKFORT		CLEVELAND STREET		

CONTRACT NO. 99234

NOTES:

1. ALL CONCRETE SHALL BE PAID FOR AT THE UNIT PRICE FOR CONCRETE STRUCTURES. CLASS SI CONCRETE SHALL BE USED THROUGHOUT.
2. ALL REINFORCEMENT SHALL BE PAID FOR AT THE UNIT PRICE FOR REINFORCEMENT BARS.

CONCRETE COLLAR DETAILS



CAST IRON FRAME, SPECIAL TYPE 1

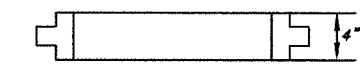

CAST IRON FRAME, SPECIAL TYPE 2

NOTES - INLETS SPECIAL, TYPE 1

CLASS SI CONCRETE SHALL BE USED THROUGHOUT.

THE INLET SHALL BE PAID FOR AT THE CONTRACT UNIT PRICE FOR INLET SPECIAL TYPE 1, WHICH PRICE SHALL INCLUDE THE COST OF THE CAST IRON FRAME, SPECIAL TYPE 2, WITH TYPE 1 CLOSED LID AND REINFORCEMENT BARS AND SHALL BE PAYMENT IN FULL FOR FURNISHING ALL MATERIAL AND FOR CONSTRUCTING THE WORK COMPLETE IN PLACE.

THE INLET MAY BE PRECAST OR MAY BE CAST IN PLACE. JOINTS AND STEEL BARS IN THE WALLS SHALL BE OMITTED IF CAST IN PLACE. IF PRECAST, THE JOINTS AND STEEL BARS SHALL BE PLACED AS SHOWN.

THE DEPTH OF THE INLET SHALL BE VARIED TO FIT FIELD CONDITIONS.

THE LID MAY BE CAST SEPARATELY OR MONOLITHICALLY WITH THE WALLS. TRAPEZIODAL OPENING IN DIRECTION OF DITCH FLOWLINE.

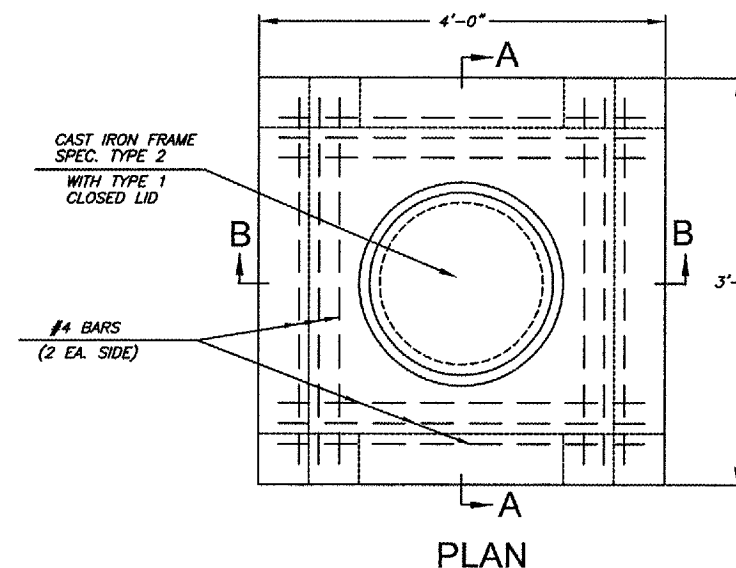

PLAN

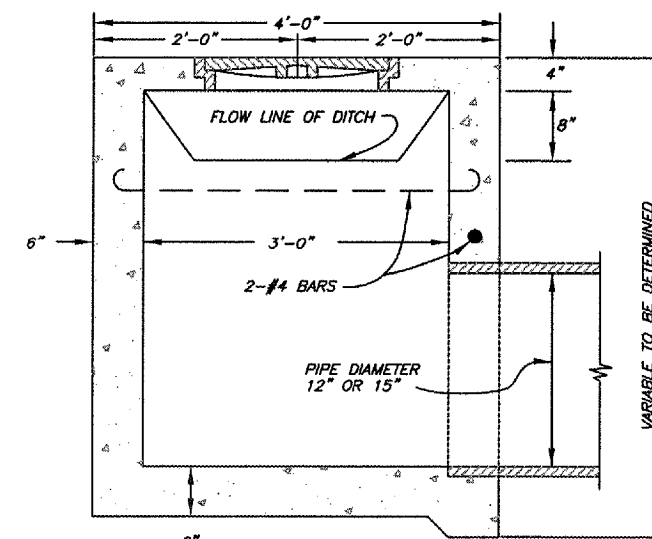

SECTION B-B

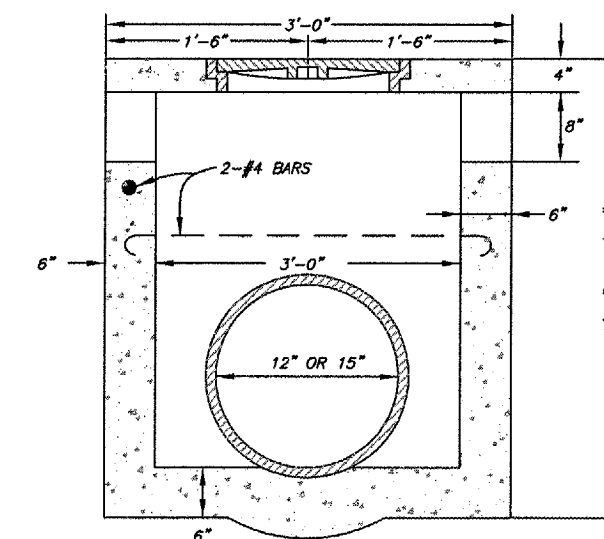

SECTION A-A

DETAIL - INLETS, SPECIAL, TYPE 1

ROUTE	SECTION	COUNTY	TOTAL SHEETS	SHEET NO.
9477	05-00051-00-RP	FRANKLIN	23	15
CITY OF WEST FRANKFORT		CLEVELAND STREET		

CONTRACT NO. 99234

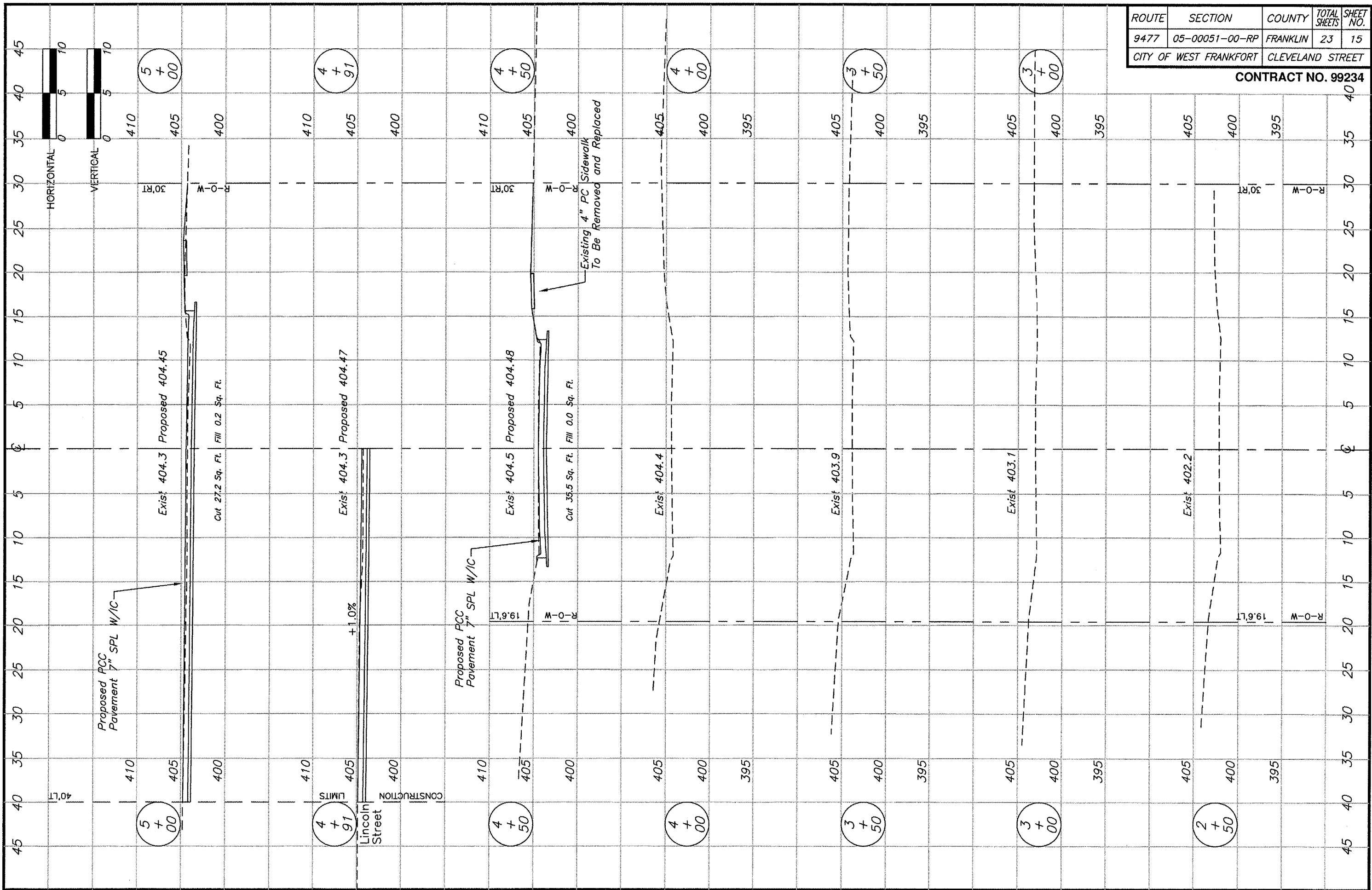

ROUTE	SECTION	COUNTY	TOTAL SHEETS	SHEET NO.
9477	05-00051-00-RP	FRANKLIN	23	16
CITY OF WEST FRANKFORT		CLEVELAND STREET		

CONTRACT NO. 99234

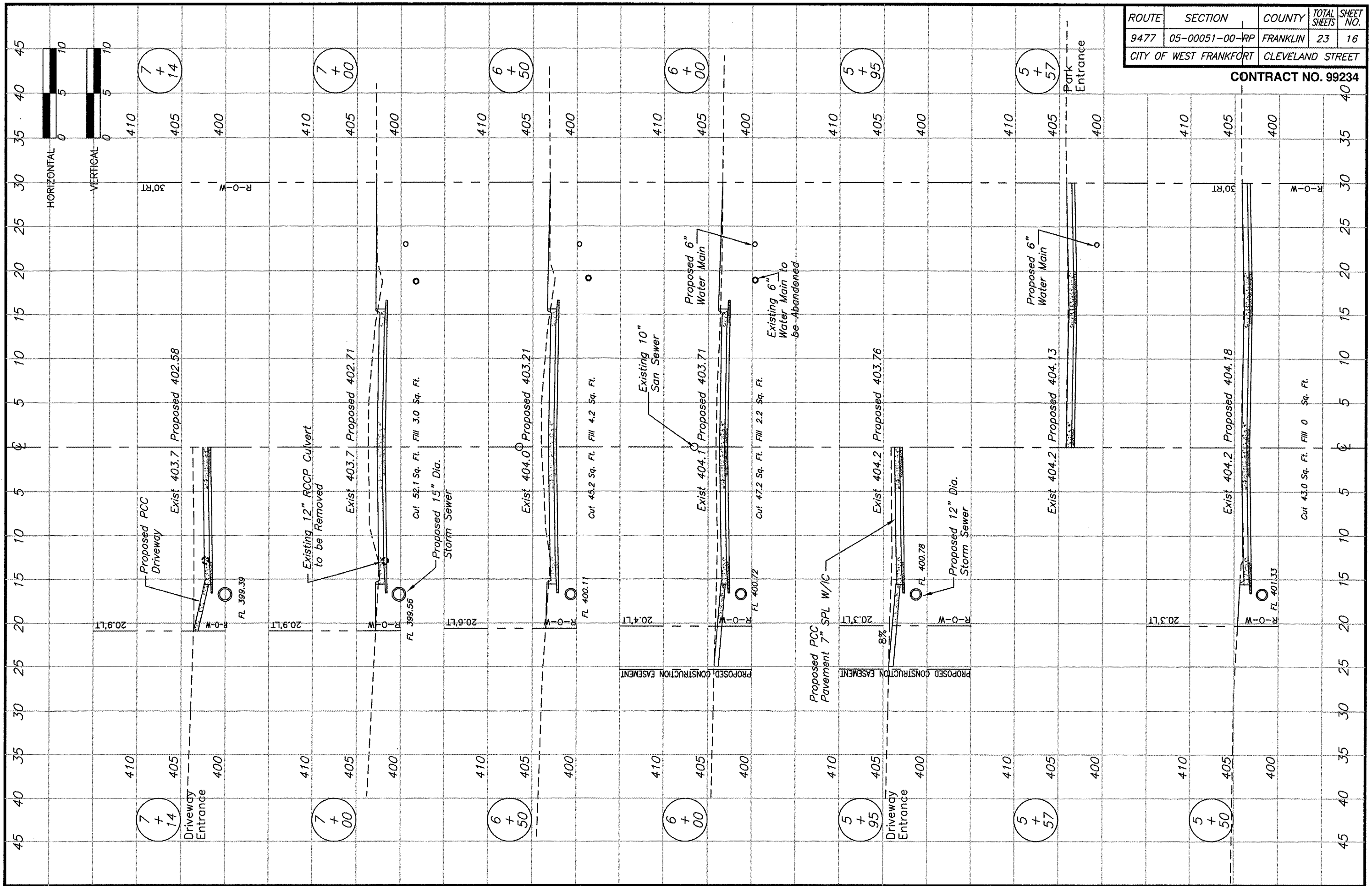



ROUTE	SECTION	COUNTY	TOTAL SHEETS	SHEET NO.
9477	05-00051-00-RP	FRANKLIN	23	17
CITY OF WEST FRANKFORT		CLEVELAND STREET		

CONTRACT NO. 99234

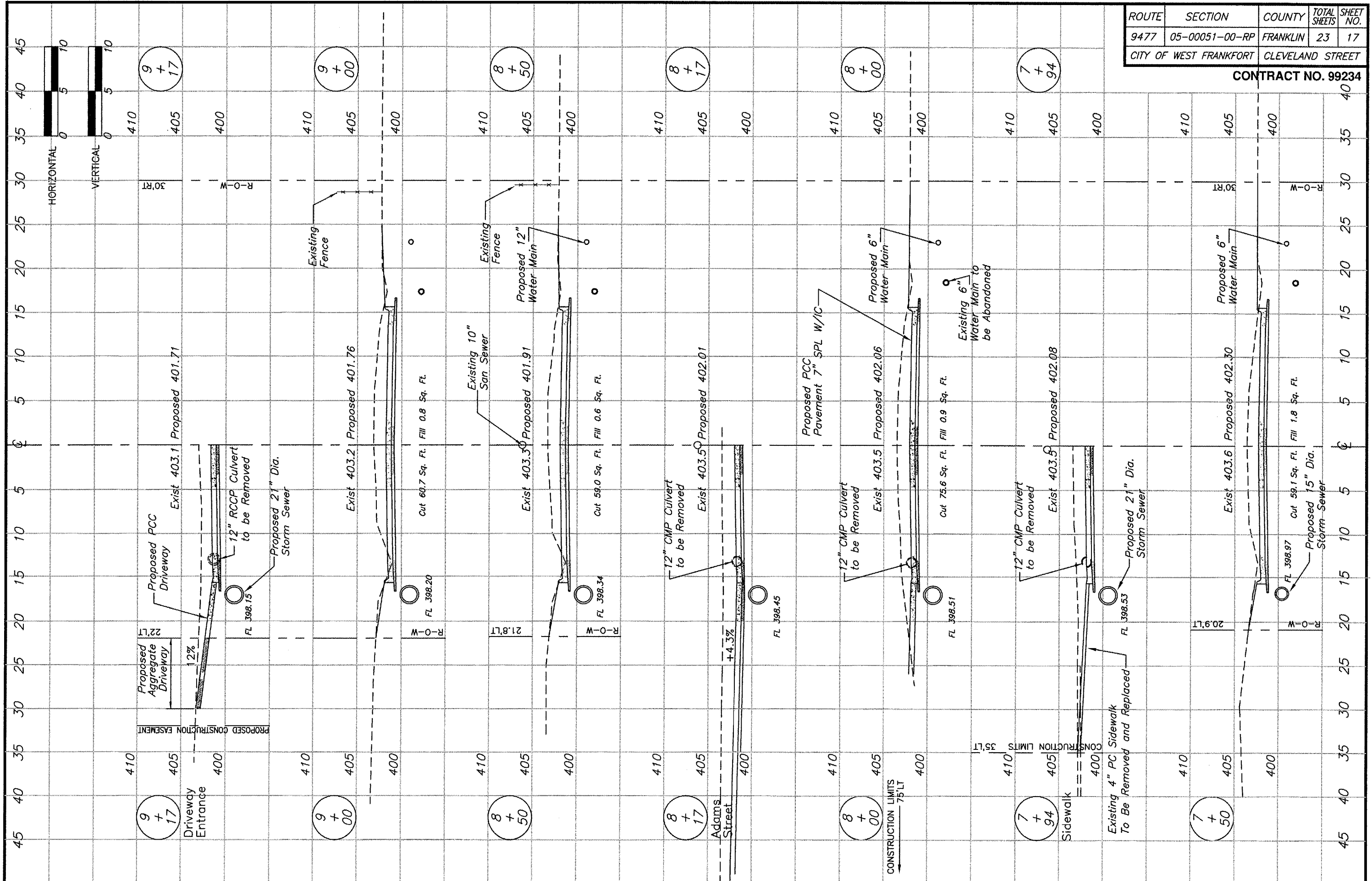

ROUTE	SECTION	COUNTY	TOTAL SHEETS	SHEET NO.
9477	05-00051-00-RP	FRANKLIN	23	18
CITY OF WEST FRANKFORT		CLEVELAND STREET		

CONTRACT NO. 99234

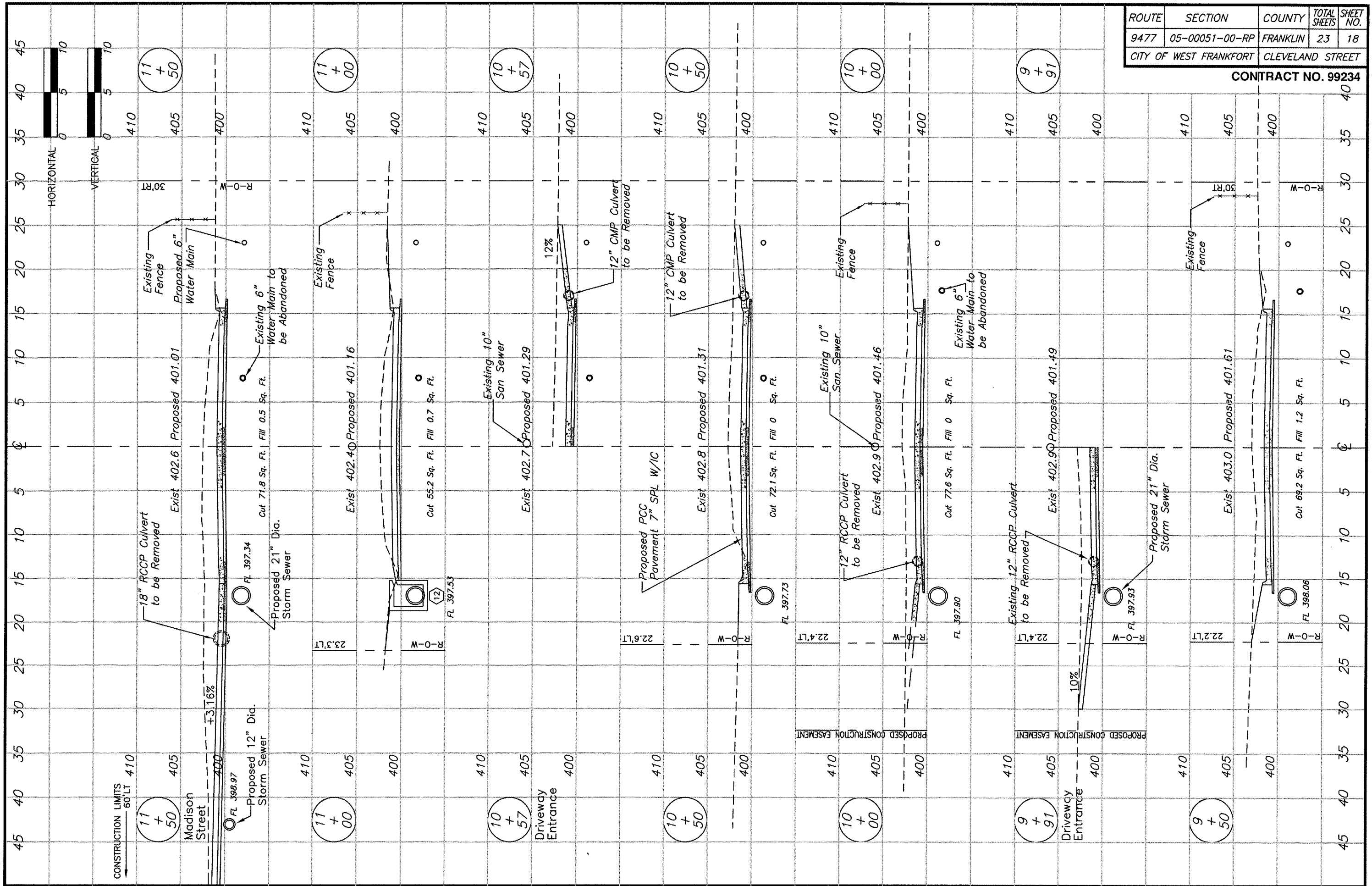

ROUTE	SECTION	COUNTY	TOTAL SHEETS	SHEET NO.
9477	05-00051-00-RP	FRANKLIN	23	19
CITY OF WEST FRANKFORT		CLEVELAND STREET		

CONTRACT NO. 99234

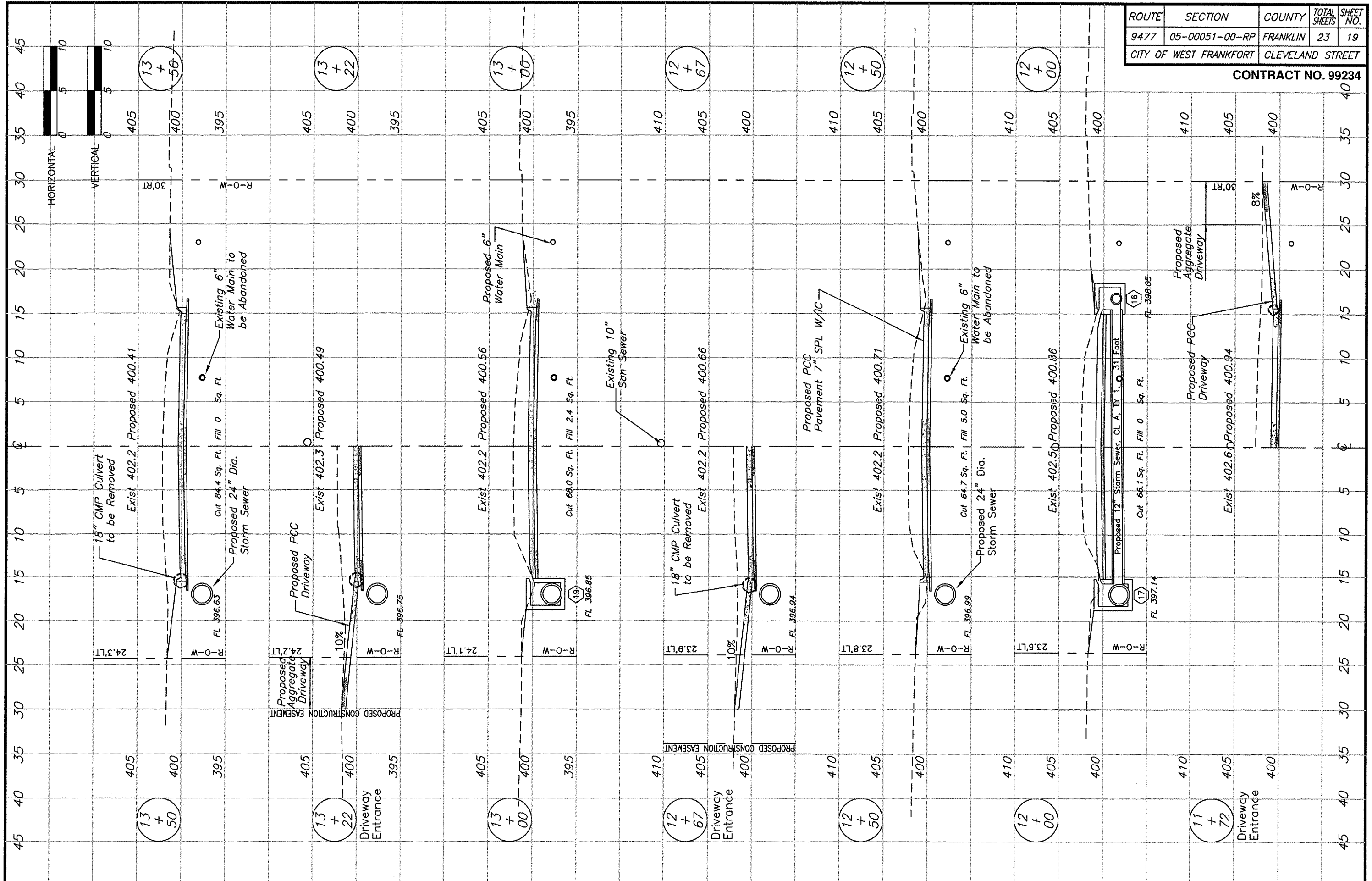

ROUTE	SECTION	COUNTY	TOTAL SHEETS	SHEET NO.
9477	05-00051-00-RP	FRANKLIN	23	20
CITY OF WEST FRANKFORT		CLEVELAND STREET		

CONTRACT NO. 99234

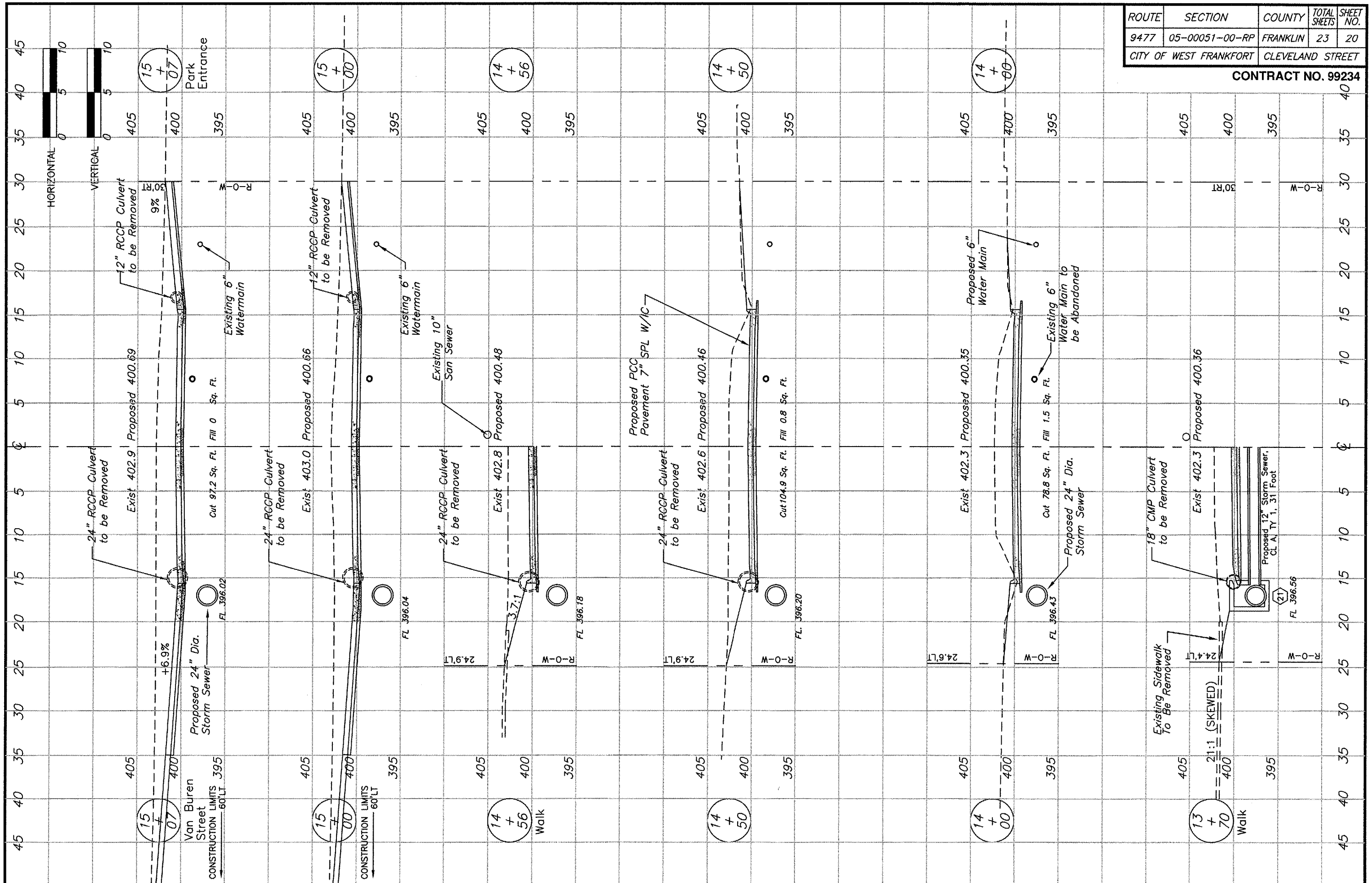

ROUTE	SECTION	COUNTY	TOTAL SHEETS	SHEET NO.
9477	05-00051-00-RP	FRANKLIN	23	21
CITY OF WEST FRANKFORT		CLEVELAND STREET		

CONTRACT NO. 99234

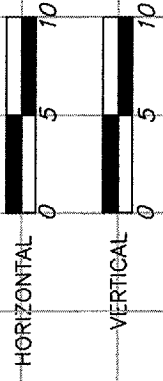
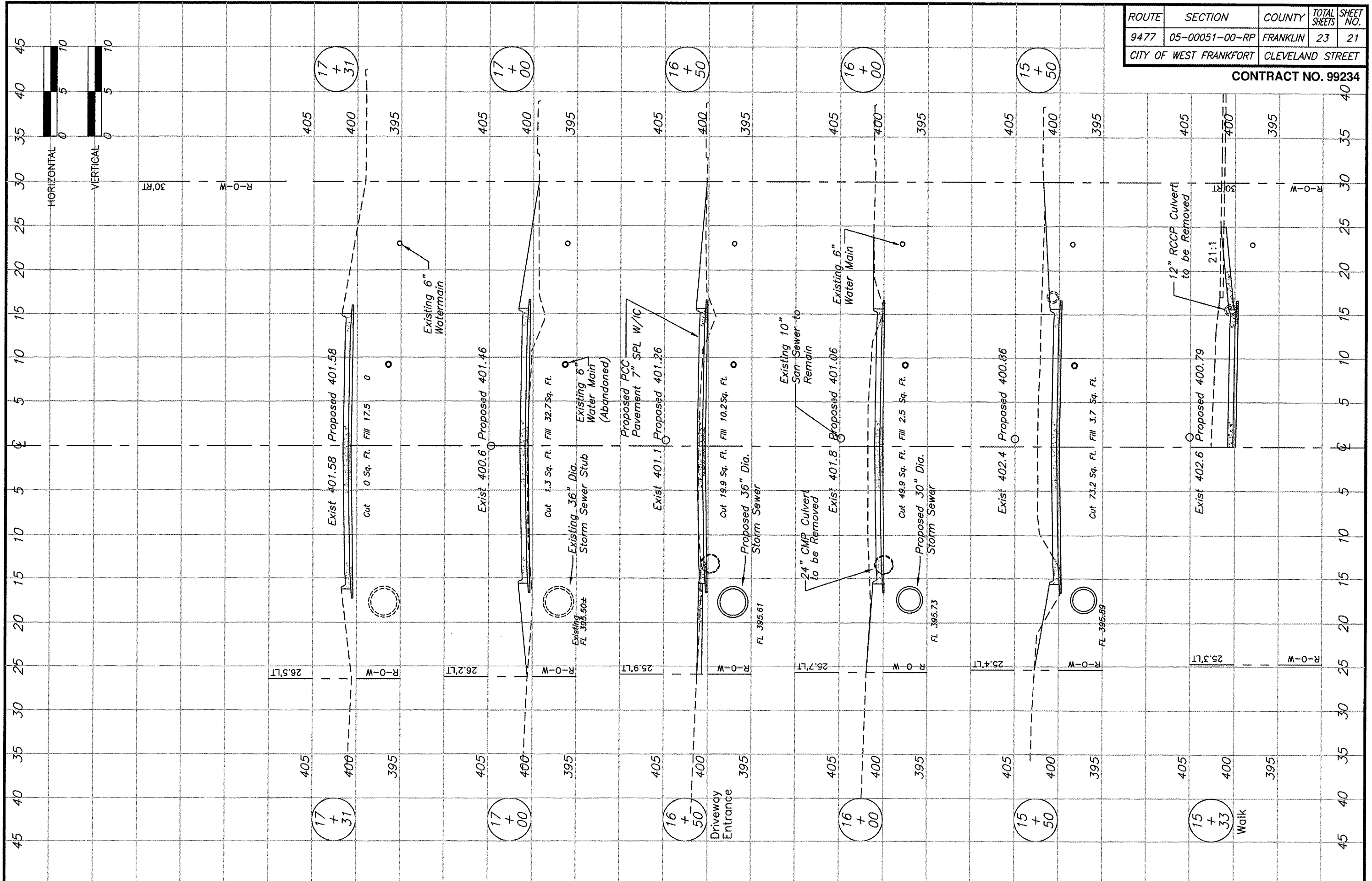

ROUTE	SECTION	COUNTY	TOTAL SHEETS	SHEET NO.
9477	05-00051-00-RP	FRANKLIN	23	22
CITY OF WEST FRANKFORT		CLEVELAND STREET		

CONTRACT NO. 99234

- GENERAL NOTES:**
- In issuing the permit for this project, the Illinois Environmental Protection Agency acknowledges that the firm of Brown & Roberts, Inc. has not been employed to furnish any engineering observation for this project. Brown & Roberts, Inc., nor the engineer who seals these plans, therefore, make no representations as to the compliance of the installation of this project with IEPA existing rules, regulations, policies, or laws.
  - The construction of the water mains on this project shall be performed according to the "Standard Specifications for Water and Sewer Main Construction in Illinois", latest edition, and as required by 35 ILL. ADM. Code 653.119.
  - Watermains shall be separated for septic tanks, disposal fields, and seepage beds by a minimum of 25 feet.
  - The watermains shall comply with ASTM D2241.
  - The watermain joints shall comply with ASTM FA77 and shall be pressure rated in accordance with ASTM D3139.

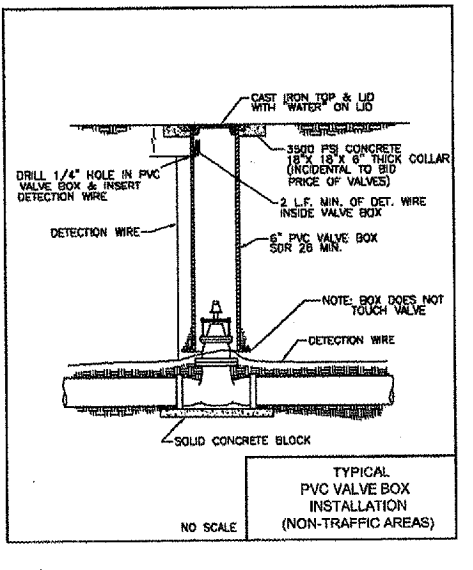
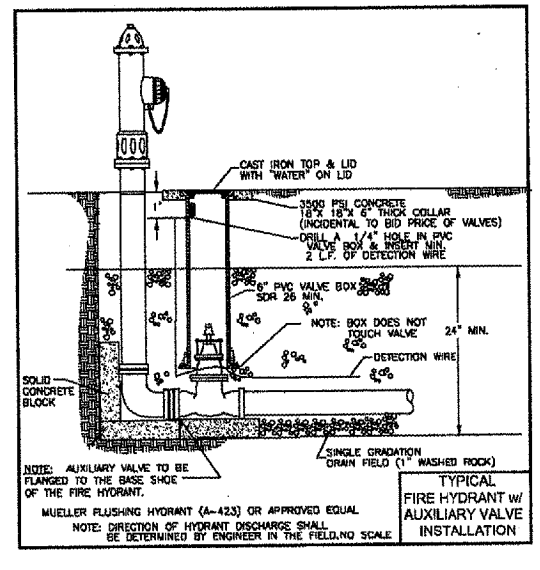
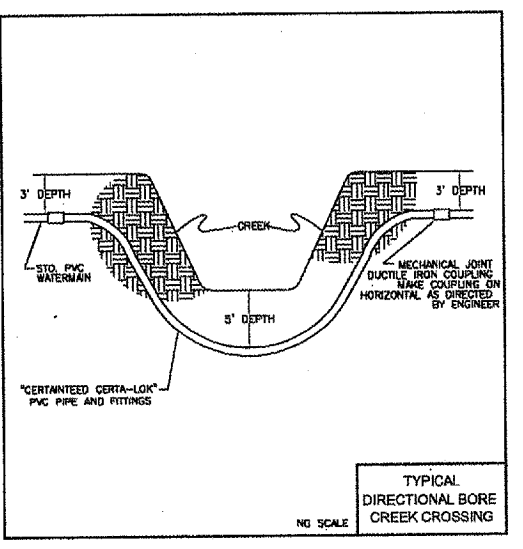
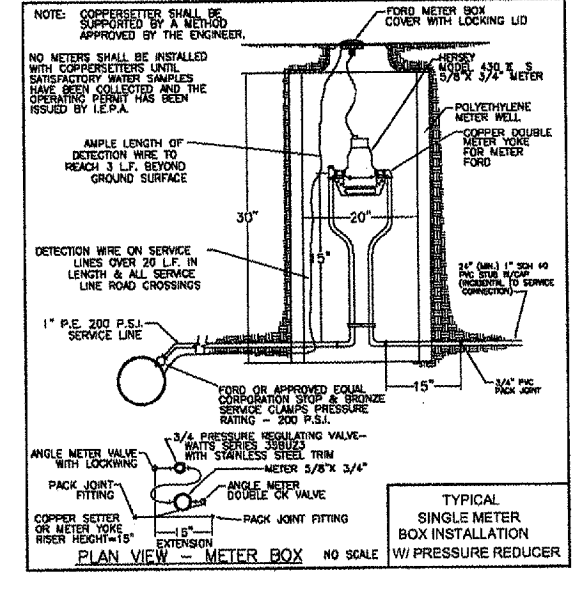
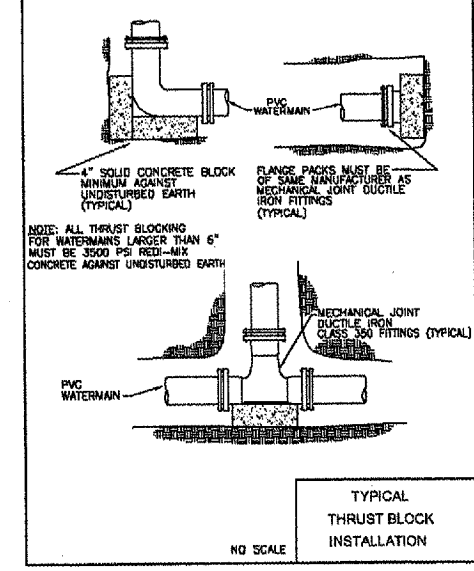
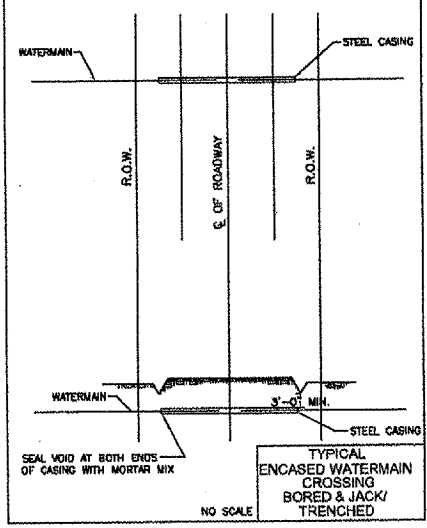
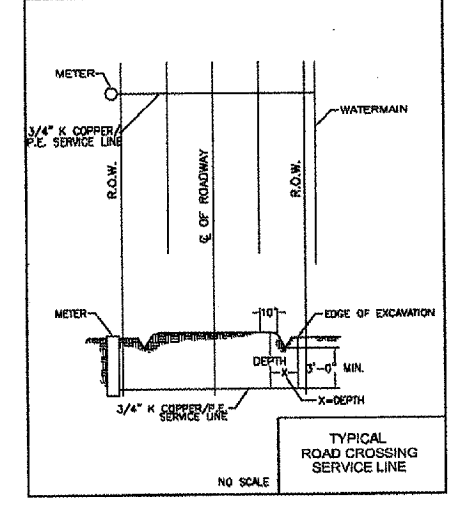
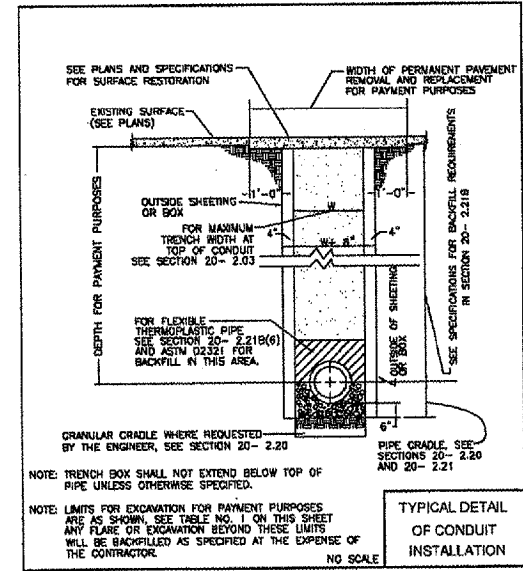
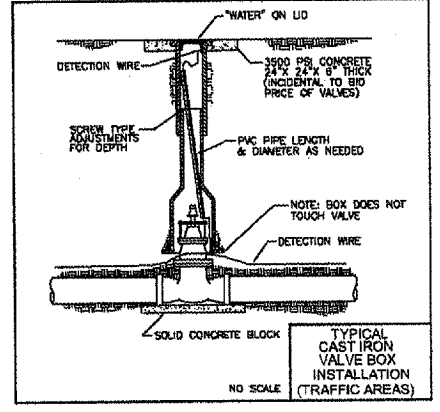
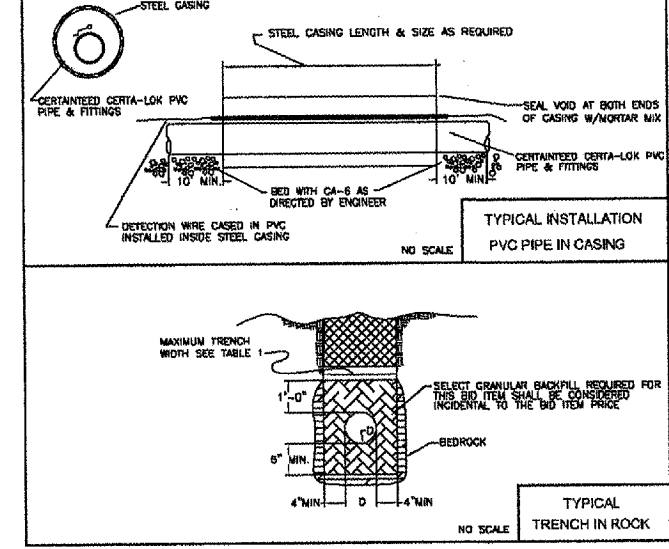
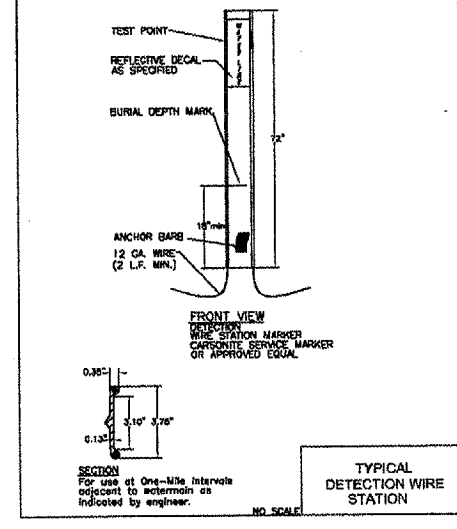
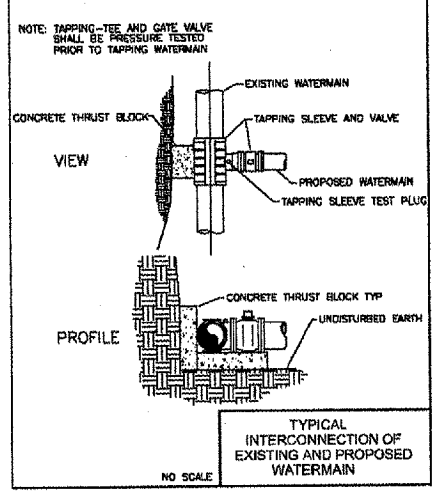

INSIDE DIAMETER OF CONDUIT IN INCHES	PAYMENT QUANTITIES PER FOOT OF CONDUIT									
	SECT. 20-2.03 MAXIMUM TRENCH WIDTH AT TOP OF CONDUIT W+8'	SECT. 20-2.21C SELECT BACKFILL CU. YDS./FT. OF CONDUIT W+8'	SECT. 20-2.20B CONCRETE CRADLE CU. YDS./FT. W+8'	PERMANENT TYPE PAINT OR DRIVE PAINT & REPLACEMENT SQ. YDS./FT. W+8'	CURB OR GUTTER & REPLACEMENT W+8'	CONCRETE OR BRICK SIDEWALK REMOVAL & REPLACEMENT SQ. FT./FT. W+8'	SECT. 21-2.01A(1) TEMPORARY SURFACE OVER TRENCH CU. YDS./FT. W+8'	SECT. 21-2.01A(2) GRANULAR BACKFILL 1 FT. OVER TOP OF PIPE CU. YDS./FT. W+8'		
6	0.117	0.09	0.07	0.17	0.17	0.17	0.06	0.16		
8	0.117	0.10	0.07	0.17	0.17	0.17	0.06	0.16		
10	0.117	0.11	0.07	0.17	0.17	0.17	0.06	0.16		
12	0.12	0.12	0.07	0.17	0.17	0.17	0.06	0.16		
14	0.13	0.13	0.07	0.17	0.17	0.17	0.06	0.16		
16	0.14	0.14	0.07	0.17	0.17	0.17	0.06	0.16		
18	0.15	0.15	0.07	0.17	0.17	0.17	0.06	0.16		
20	0.16	0.16	0.07	0.17	0.17	0.17	0.06	0.16		
22	0.17	0.17	0.07	0.17	0.17	0.17	0.06	0.16		
24	0.18	0.18	0.07	0.17	0.17	0.17	0.06	0.16		
26	0.19	0.19	0.07	0.17	0.17	0.17	0.06	0.16		
28	0.20	0.20	0.07	0.17	0.17	0.17	0.06	0.16		
30	0.21	0.21	0.07	0.17	0.17	0.17	0.06	0.16		
32	0.22	0.22	0.07	0.17	0.17	0.17	0.06	0.16		
34	0.23	0.23	0.07	0.17	0.17	0.17	0.06	0.16		
36	0.24	0.24	0.07	0.17	0.17	0.17	0.06	0.16		
38	0.25	0.25	0.07	0.17	0.17	0.17	0.06	0.16		
40	0.26	0.26	0.07	0.17	0.17	0.17	0.06	0.16		
42	0.27	0.27	0.07	0.17	0.17	0.17	0.06	0.16		
44	0.28	0.28	0.07	0.17	0.17	0.17	0.06	0.16		
46	0.29	0.29	0.07	0.17	0.17	0.17	0.06	0.16		
48	0.30	0.30	0.07	0.17	0.17	0.17	0.06	0.16		
50	0.31	0.31	0.07	0.17	0.17	0.17	0.06	0.16		
52	0.32	0.32	0.07	0.17	0.17	0.17	0.06	0.16		
54	0.33	0.33	0.07	0.17	0.17	0.17	0.06	0.16		
56	0.34	0.34	0.07	0.17	0.17	0.17	0.06	0.16		
58	0.35	0.35	0.07	0.17	0.17	0.17	0.06	0.16		
60	0.36	0.36	0.07	0.17	0.17	0.17	0.06	0.16		
62	0.37	0.37	0.07	0.17	0.17	0.17	0.06	0.16		
64	0.38	0.38	0.07	0.17	0.17	0.17	0.06	0.16		
66	0.39	0.39	0.07	0.17	0.17	0.17	0.06	0.16		
68	0.40	0.40	0.07	0.17	0.17	0.17	0.06	0.16		
70	0.41	0.41	0.07	0.17	0.17	0.17	0.06	0.16		
72	0.42	0.42	0.07	0.17	0.17	0.17	0.06	0.16		
74	0.43	0.43	0.07	0.17	0.17	0.17	0.06	0.16		
76	0.44	0.44	0.07	0.17	0.17	0.17	0.06	0.16		
78	0.45	0.45	0.07	0.17	0.17	0.17	0.06	0.16		
80	0.46	0.46	0.07	0.17	0.17	0.17	0.06	0.16		
82	0.47	0.47	0.07	0.17	0.17	0.17	0.06	0.16		
84	0.48	0.48	0.07	0.17	0.17	0.17	0.06	0.16		
86	0.49	0.49	0.07	0.17	0.17	0.17	0.06	0.16		
88	0.50	0.50	0.07	0.17	0.17	0.17	0.06	0.16		
90	0.51	0.51	0.07	0.17	0.17	0.17	0.06	0.16		
92	0.52	0.52	0.07	0.17	0.17	0.17	0.06	0.16		
94	0.53	0.53	0.07	0.17	0.17	0.17	0.06	0.16		
96	0.54	0.54	0.07	0.17	0.17	0.17	0.06	0.16		
98	0.55	0.55	0.07	0.17	0.17	0.17	0.06	0.16		
100	0.56	0.56	0.07	0.17	0.17	0.17	0.06	0.16		
102	0.57	0.57	0.07	0.17	0.17	0.17	0.06	0.16		
104	0.58	0.58	0.07	0.17	0.17	0.17	0.06	0.16		
106	0.59	0.59	0.07	0.17	0.17	0.17	0.06	0.16		
108	0.60	0.60	0.07	0.17	0.17	0.17	0.06	0.16		

ROUTE	SECTION	COUNTY	TOTAL SHEETS	SHEET NO.
9477	05-00051-00-RP	FRANKLIN	23	23
CITY OF WEST FRANKFORT		CLEVELAND STREET		

CONTRACT NO. 99234

WHEN PROPOSED SEWER (OR WATER) IS LOCATED 10 FEET OR MORE FROM EXISTING WATER (OR SEWER), NO SPECIAL CONSTRUCTION REQUIRED. SEE SECTION 41-2.01B (1)

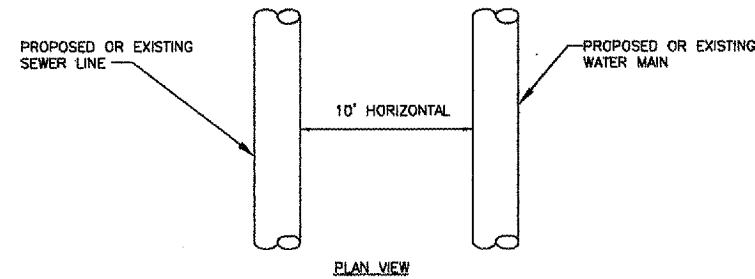

WHEN PROPOSED SEWER (OR WATER) IS LOCATED LESS THAN 10 FEET FROM EXISTING WATER (OR SEWER), DETAILS BELOW SHALL APPLY. SEE SECTION 41-2.01B (2)

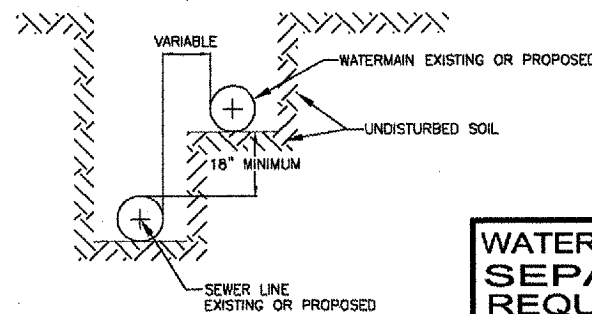

**WATER AND SEWER SEPARATION REQUIREMENTS HORIZONTAL SEPARATION**

NO SCALE

PROPOSED WATERMAIN ABOVE EXISTING SEWER LINE WITH LESS THAN 18" VERTICAL SEPARATION.

NOTE: COMPACTION REQUIREMENTS REFER TO 20-2.20B

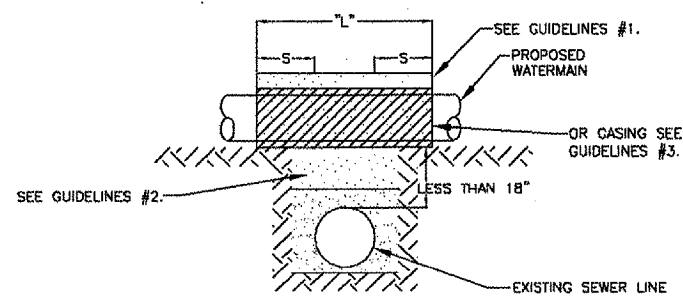

**GUIDELINES**

1. OMIT SELECT GRANULAR EMBEDMENT AND GRANULAR BACKFILL TO ONE (1) FOOT OVER TOP OF WATERMAIN AND USE SELECT EXCAVATED MATERIAL (CLASS IV) AND COMPACT THE LENGTH OF "L".
2. IF SELECT GRANULAR BACKFILL EXISTS, REMOVE WITHIN WIDTH OF EXISTING SEWER LINE TRENCH AND REPLACE WITH SELECT EXCAVATED MATERIAL (CLASS IV) AND COMPACT.
3. USE "L" FEET OF WATER MAIN MATERIAL FOR CASING OF PROPOSED WATERMAIN AND SEAL ENDS OF CASING.
4. POINT LOADS SHALL NOT BE ALLOWED BETWEEN MAIN CASING AND SEWER.

NOTE: "S" THE LENGTH NECESSARY TO PROVIDE 10 FEET OF SEPARATION AS MEASURED PERPENDICULAR TO EXISTING SEWER LINE.

**WATER AND SEWER SEPARATION REQUIREMENTS VERTICAL SEPARATION**

NO SCALE

PLACEMENT OF WATERMAIN BELOW EXISTING OR PROPOSED SEWER LINE WITH LESS THAN 18" MINIMUM VERTICAL SEPARATION. NOT ALLOWED

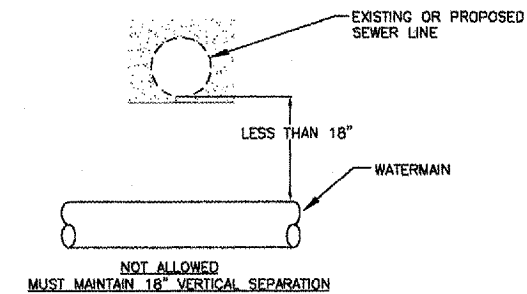

**WATER AND SEWER SEPARATION REQUIREMENTS VERTICAL SEPARATION**

NO SCALE

PROPOSED WATERMAIN BELOW EXISTING SEWER LINE WITH 18" MINIMUM VERTICAL SEPARATION.

NOTE: COMPACTION REQUIREMENTS REFER TO 20-2.20B

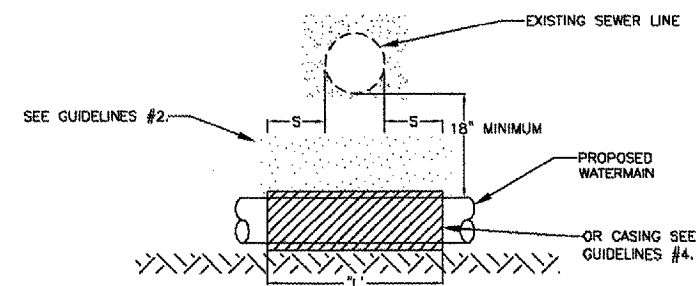

NOTE: "S" THE LENGTH NECESSARY TO PROVIDE 10 FEET OF SEPARATION AS MEASURED PERPENDICULAR TO EXISTING SEWER LINE.

**GUIDELINES**

1. OMIT SELECT GRANULAR EMBEDMENT AND GRANULAR BACKFILL TO ONE (1) FOOT OVER TOP OF WATERMAIN AND USE SELECT EXCAVATED MATERIAL (CLASS IV) AND COMPACT THE LENGTH OF "L".
2. IF SELECT GRANULAR BACKFILL EXISTS, REMOVE WITHIN WIDTH OF EXISTING SEWER LINE TRENCH AND REPLACE WITH SELECT EXCAVATED MATERIAL (CLASS IV) AND COMPACT.
3. PROVIDE ADEQUATE SUPPORT FOR EXISTING SEWER LINE TO PREVENT DAMAGE DUE TO SETTLEMENT.
4. USE "L" FEET OF WATER MAIN MATERIAL FOR CASING OF PROPOSED WATERMAIN AND SEAL ENDS OF CASING.

**WATER AND SEWER SEPARATION REQUIREMENTS VERTICAL SEPARATION**

NO SCALE

**NOTE:**

THE CONSTRUCTION OF THE WATER MAINS ON THIS PROJECT SHALL BE PERFORMED ACCORDING TO THE "STANDARD SPECIFICATIONS FOR WATER AND SEWER MAIN CONSTRUCTION IN ILLINOIS", 5TH EDITION, MAY 1996, AS REQUIRED BY 35 IL. ADM CODE 652.102(a).