

BILL OF MATERIAL

Bar	No.			Size	Length	Shape
	Pier 1	Pier 2	Pier 3			
d ₃₀ (E)	64	64	64	#6	3' - 7"	—
d ₃₁ (E)		64		#6	2' - 11"	—
d ₃₂ (E)	8		8	#6	5' - 1"	—
d ₃₃ (E)		8		#6	4' - 5"	—
h ₃₀ (E)	24	16	24	#5	2' - 9"	—
h ₃₁ (E)	12	8	12	#5	5' - 0"	—
p ₃₀ (E)	20	20	20	#6	2' - 9"	—
p ₃₁ (E)	10	10	10	#6	5' - 2"	—
u ₃₀ (E)	8	6	8	#5	5' - 10"	U
u ₃₁ (E)	4	2	4	#5	4' - 9"	U
u ₃₂ (E)	28		28	#5	6' - 11"	□
u ₃₃ (E)		28		#5	5' - 7"	□
Concrete Removal					Cu. Yd.	3.7
Concrete Structures					Cu. Yd.	22.7
Reinforcement Bars, Epoxy Coated					Pound	2,730

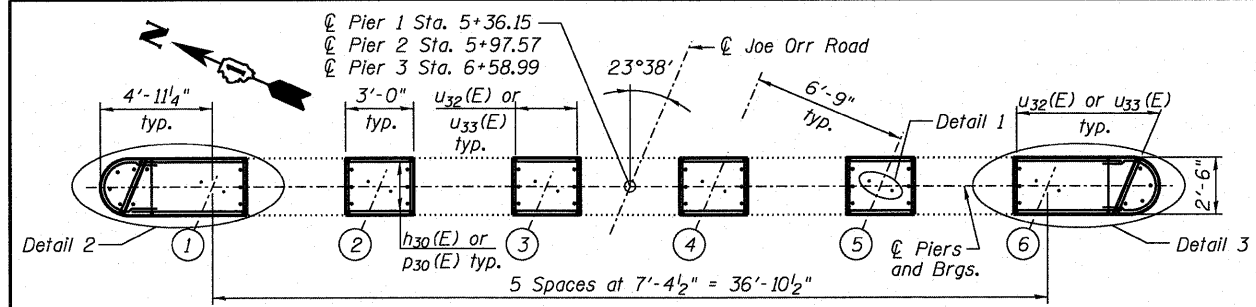

CAP PLAN

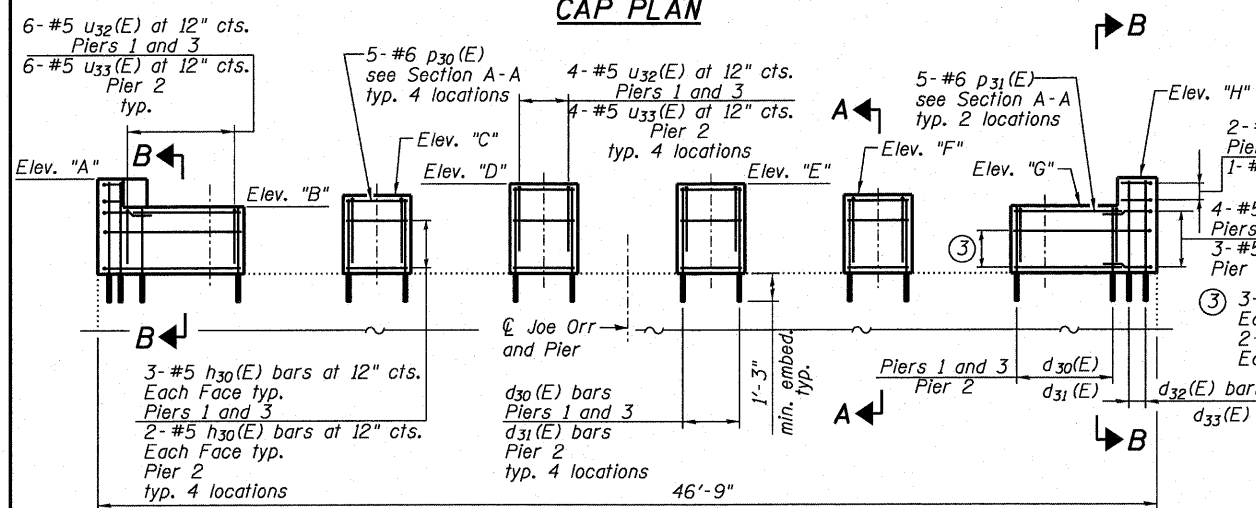

PIER ELEVATION

	Elev. "A"	Elev. "B"	Elev. "C"	Elev. "D"	Elev. "E"	Elev. "F"	Elev. "G"	Elev. "H"
Pier 1	649.71	648.21	648.34	648.48	648.50	648.42	648.34	649.84
Pier 2	650.18	648.68	648.79	648.89	648.89	648.79	648.68	650.18
Pier 3	649.84	648.34	648.43	648.51	648.48	648.35	648.21	649.71

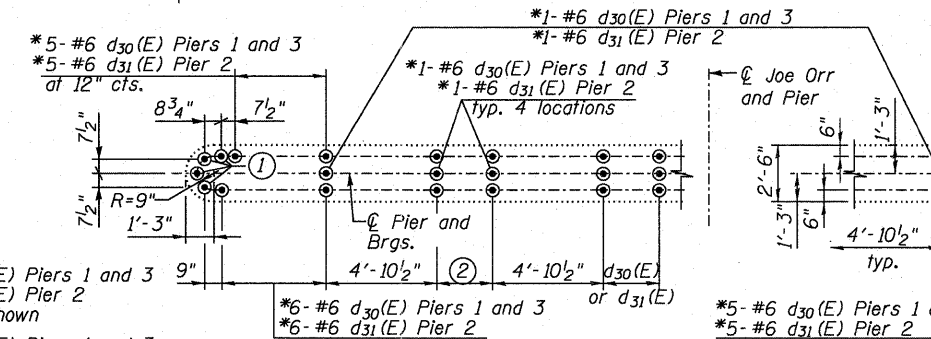

DOWEL LAYOUT

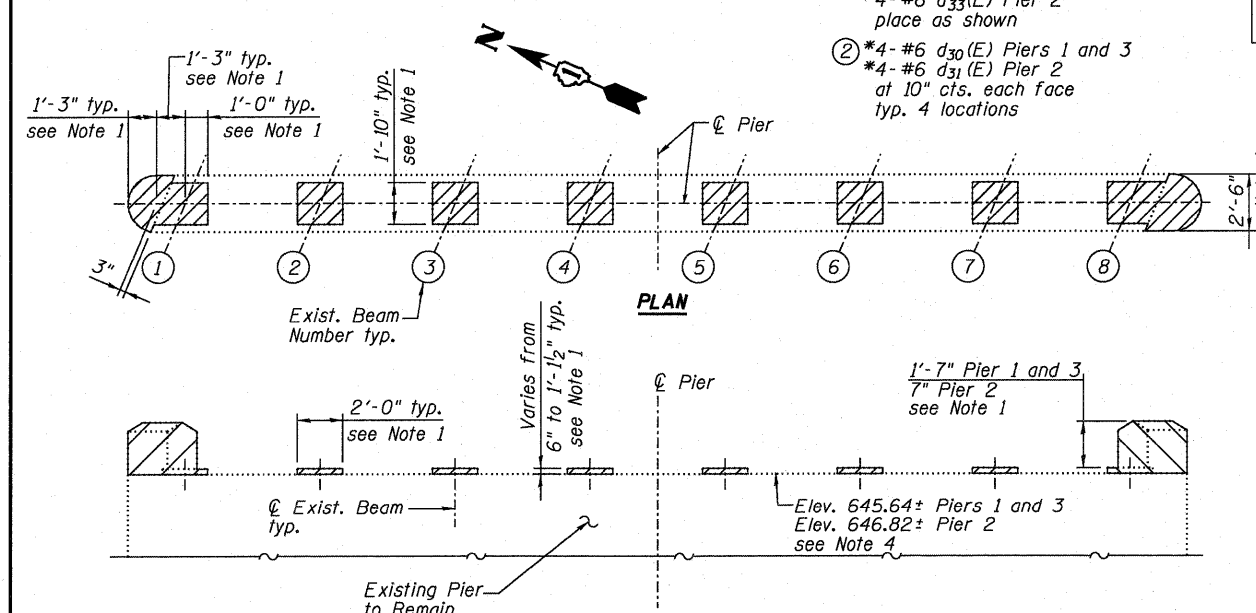

REMOVAL SKETCH

LEGEND

Concrete Removal

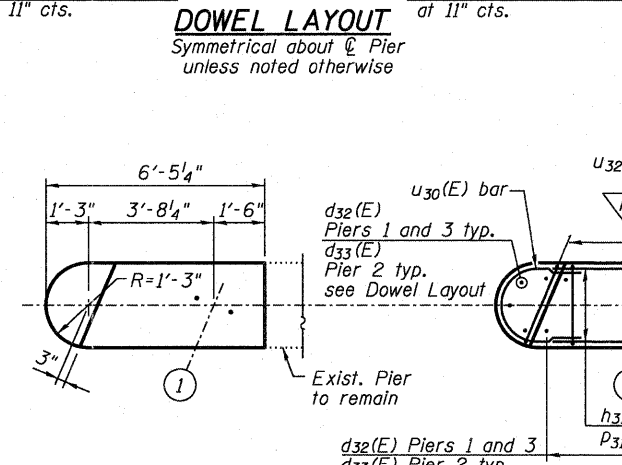

DETAIL 2

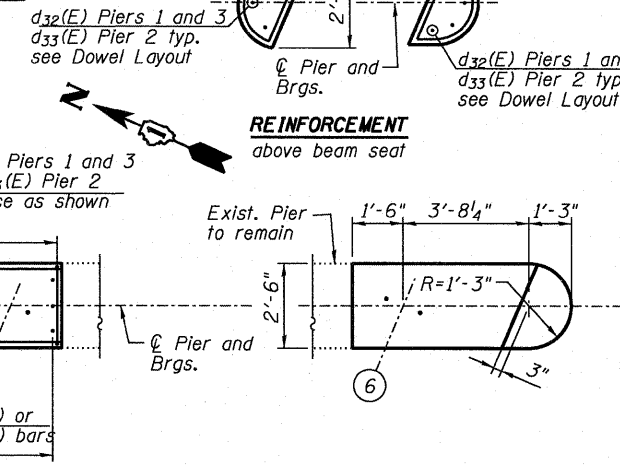

DETAIL 3

Notes:

1. Dimensions taken from existing plans. To be verified by the Contractor in the field before starting construction.
2. Space reinforcement in pedestals to miss anchor bolts.
3. For Bearing Details see sheet S18.
4. Elevation was taken from available survey. The Contractor shall verify in field before beginning of work.

FILE NAME =	DESIGNED EV	REVISED -
...0162121-025-PierDetails.dgn	DRAWN JCP	REVISED -
PLOT TIME = 11:36:43 PM	CHECKED PC	REVISED -
PLOT DATE = 6/30/2011	DATE 07 01 2011	REVISED -

SEPSTEIN
 800 WEST FLATION STREET
 CHICAGO, ILLINOIS 60611-1208
 TEL. 312 454 9100
 FAX 312 556 1217
 WEB www.sepsteincivil.com

STATE OF ILLINOIS
DEPARTMENT OF TRANSPORTATION

PIER MODIFICATION DETAILS
STRUCTURE NO. 016-2121
 SHEET NO. S25 OF S29 SHEETS

F.A.P. RTE.	SECTION	COUNTY	TOTAL SHEETS	SHEET NO.
332	0101.1 BR-3	COOK	60	40
CONTRACT NO. 62421			ILLINOIS FED. AID PROJECT	