

OPTION 1

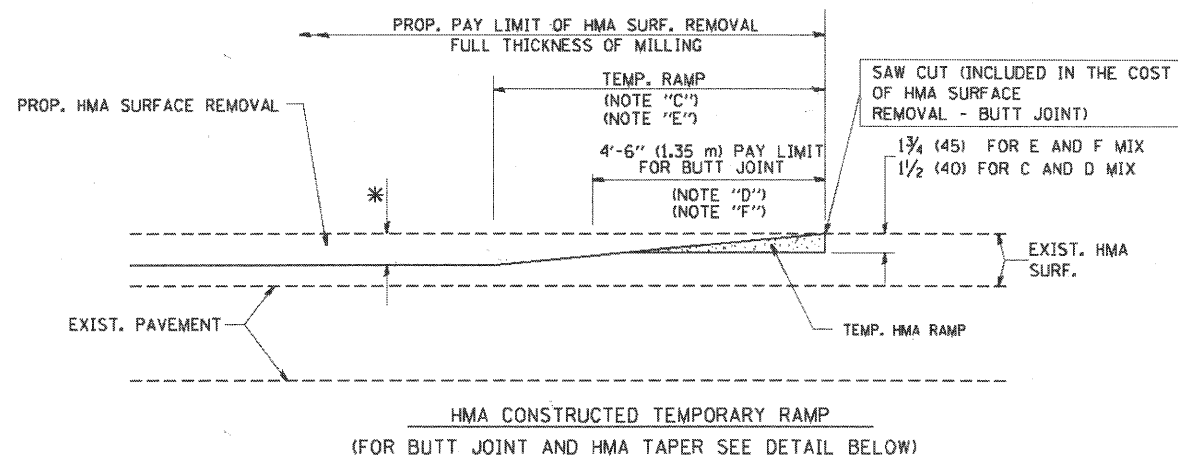

OPTION 2

TYPICAL TEMPORARY RAMP

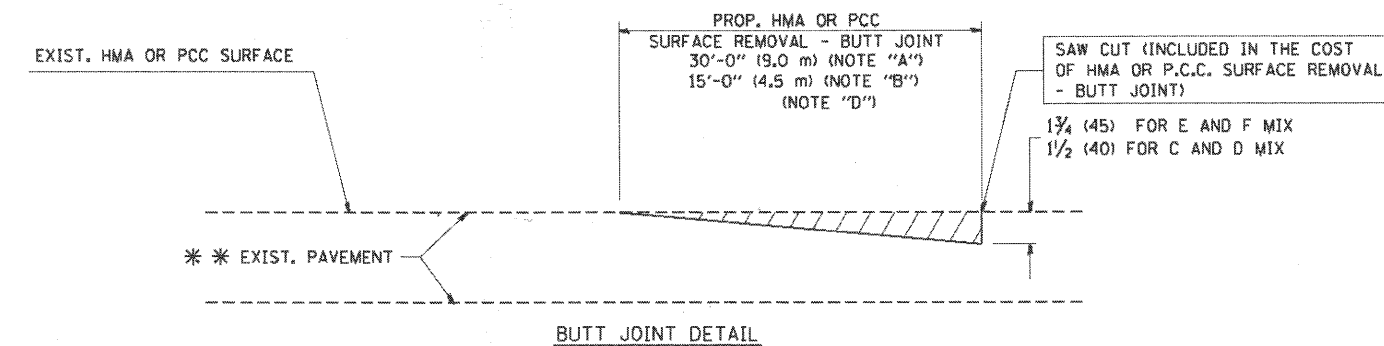

BUTT JOINT DETAIL

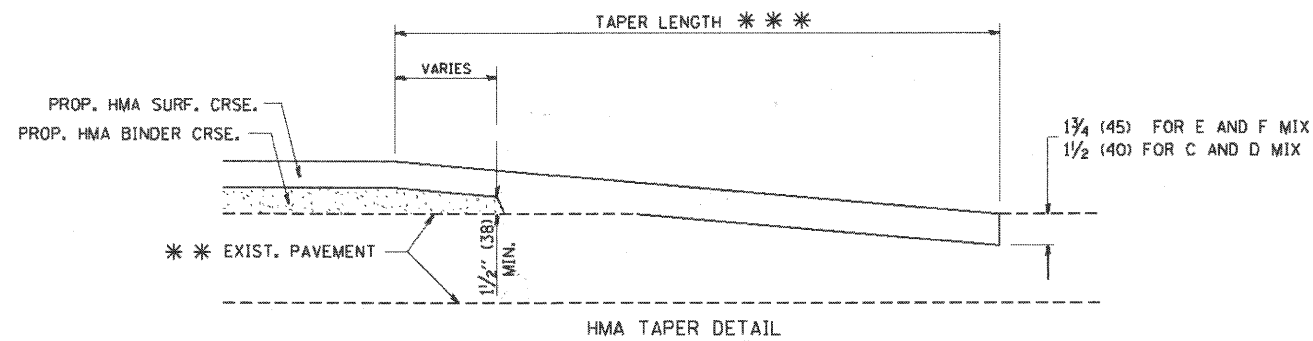

HMA TAPER DETAIL

TYPICAL BUTT JOINT AND HMA TAPER FOR RESURFACING ONLY

*** PC CONCRETE, HMA OR HMA RESURFACED PAVEMENT.

NOTES

- A: MAINLINE ROADWAYS AND MAJOR SIDE ROADS.
- B: MINOR SIDE ROADS.
- C: THE TEMP. RAMP SHALL BE CONSTRUCTED IMMEDIATELY UPON REMOVAL OF THE EXISTING HMA SURFACE.
- D: THE BUTT JOINT SHALL BE CONSTRUCTED IMMEDIATELY PRIOR TO PLACING THE PROPOSED HMA COURSES.
- E: TAPER THE TEMP. RAMP AT A RATE OF 3'-0" (900 mm) PER 1 INCH (25 mm) OF MILLING THICKNESS.
- F: INSTALLATION AND REMOVAL OF THE 4'-6" (1.35 m) TEMP. RAMP IS INCLUDED IN COST OF HMA SURFACE REMOVAL - BUTT JOINT
- G: SEE ARTICLE 406.08 AND 406.14 OF THE STANDARD SPECIFICATIONS FOR "HMA AND/OR PCC SURFACE REMOVAL, BUTT JOINT".
- * SEE TYPICAL SECTIONS FOR MILLING THICKNESS.
- *** 20'-0" (6.1 m) PER 1 (25) RESURFACING (NOTE "A")
10'-0" (3.0 m) PER 1 (25) RESURFACING (NOTE "B")

BASIS OF PAYMENT:

THE BUTT JOINT WILL BE PAID FOR AT THE CONTRACT UNIT PRICE PER SQUARE YARD (SQUARE METER) FOR "HOT-MIX ASPHALT SURFACE REMOVAL - BUTT JOINT" OR FOR "PORTLAND CEMENT CONCRETE SURFACE REMOVAL - BUTT JOINT".

ALL DIMENSIONS ARE IN INCHES (MILLIMETERS) UNLESS OTHERWISE SHOWN.

TYPICAL BUTT JOINT AND HMA TAPER FOR MILLING AND RESURFACING

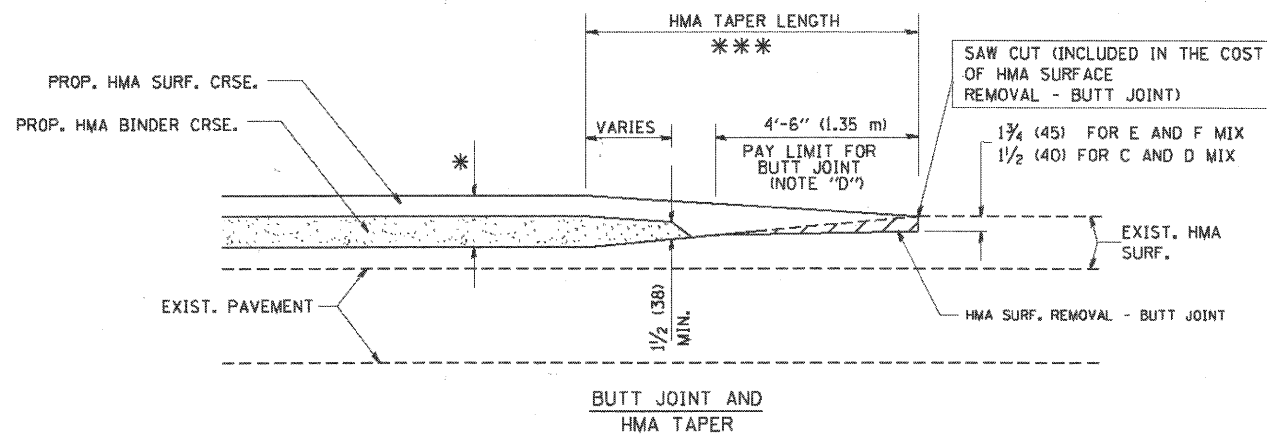

COMPANY NAME: SEC GROUP, INC.
 PROJECT CONTACT: Robert C. Davies
 CLIENT: Village of Spring Grove
 DATE PLOTTED: 6/23/2011 2:21:41 PM
 FILE NAME: 090212_De105.dgn
 PLOT DRIVER: pdf.plt
 PEN TABLE: standard-trans.tbl

SEC Group, Inc.
 An HR Green Company
 420 N. Paul Street
 Mchenry, IL 60050-1138
 L 815.385.1778 F 815.385.1781
 www.secgroupinc.com
 *Mchenry, IL *Yorkville, IL *Naperville, IL *Chicago, IL

USER NAME = sghobhobh	DESIGNED - M. DE YONG	REVISED - R. SHAH 10-25-94
FILE NAME = 090212_De105.dgn	DRAWN -	REVISED - A. ABBAS 03-21-97
PLOT SCALE = 50.00000 1/4" = 1"	CHECKED -	REVISED - M. GOMEZ 04-06-01
PLOT DATE = 6/23/2011	DATE - 06/23/2011	REVISED - R. BORO 01-01-07

VILLAGE OF SPRING GROVE

BUTT JOINT AND HMA TAPER DETAILS

SCALE: NONE	SHEET NO. 1 OF 1	SUBREDS	STA.	TD STA.
-------------	------------------	---------	------	---------

F.A.U. RTE.	SECTION	COUNTY	TOTAL SHEETS	SHEET NO.
0157	07-00012-00-BR	MCHENRY	41	37
BD400-05 BD32		CONTRACT NO. 63544		
FED. ROAD DIST. NO. 1 ILLINOIS FED. AID PROJECT				