

STATE OF ILLINOIS
DEPARTMENT OF TRANSPORTATION
DIVISION OF HIGHWAYS

**PROPOSED
HIGHWAY PLANS**

FAP ROUTE 585 (IL 92)
SECTION 128 BR
PROJECT: ACF-0585(008)
BRIDGE REPLACEMENT, AND
INSTALLATION OF WINGWALLS AT
EXISTING ACROSS ROAD BOX CULVERT
HENRY COUNTY

F.A.P. RTE.	SECTION	COUNTY	TOTAL SHEETS	SHEET NO.
585	128 BR	HENRY	106	1
FED. ROAD DIST. NO. 2	ILLINOIS CONTRACT NO. 64C20			

*106-4 = 102

FOR INDEX OF SHEETS, SEE SHEET NO. 2
FOR STATE STANDARDS, SEE SHEET NO. 2

FUNCTIONAL CLASSIFICATION
RURAL MINOR ARTERIAL
2011 ADT = 1050
SPEED LIMIT 55 MPH

STRUCTURE REMOVAL AND REPLACEMENT STA. 625 + 67.67
(EXISTING SN 037-0069) (PROPOSED SN 037-0174)
IL 92 OVER MAIN UNION DITCH

SECTION BEGINS
STA. 621 + 00.00

INSTALLATION OF WINGWALL
AND PIPE GRATE STA. 651 + 65.08
EXISTING S.N. 037-1184
IL 92 OVER DRAINAGE DITCH

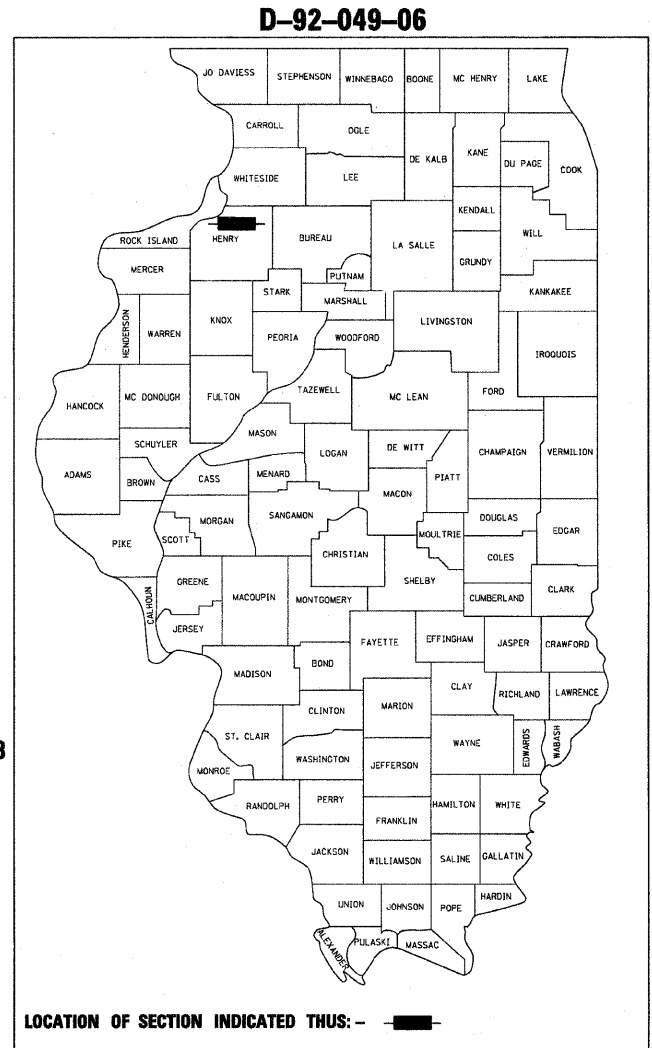

1170 SOUTH HOUDBOLT ROAD
JOLIET, ILLINOIS 60431
(815) 744-4200

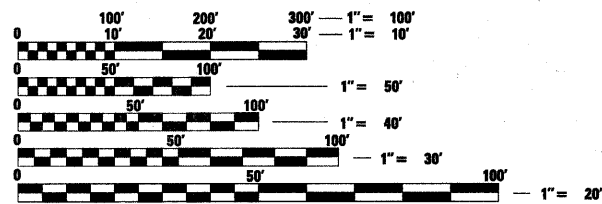

FULL SIZE PLANS HAVE BEEN PREPARED USING STANDARD
ENGINEERING SCALES. REDUCED SIZED PLANS WILL NOT
CONFORM TO STANDARD SCALES. IN MAKING MEASUREMENTS
ON REDUCED PLANS, THE ABOVE SCALES MAY BE USED.

J.U.L.I.E.
JOINT UTILITY LOCATION INFORMATION FOR EXCAVATION
1-800-892-0123
OR 811

YORKTOWN TOWNSHIP, SECTION 28

PROJECT ENGINEER: BECKY MARRUFFO
PROJECT MANAGER DERRICK LOPEZ (815) 284-5930
CONTRACT NO. 64C20

FAP ROUTE 585 HENRY COUNTY SECTION NUMBER 128 BR

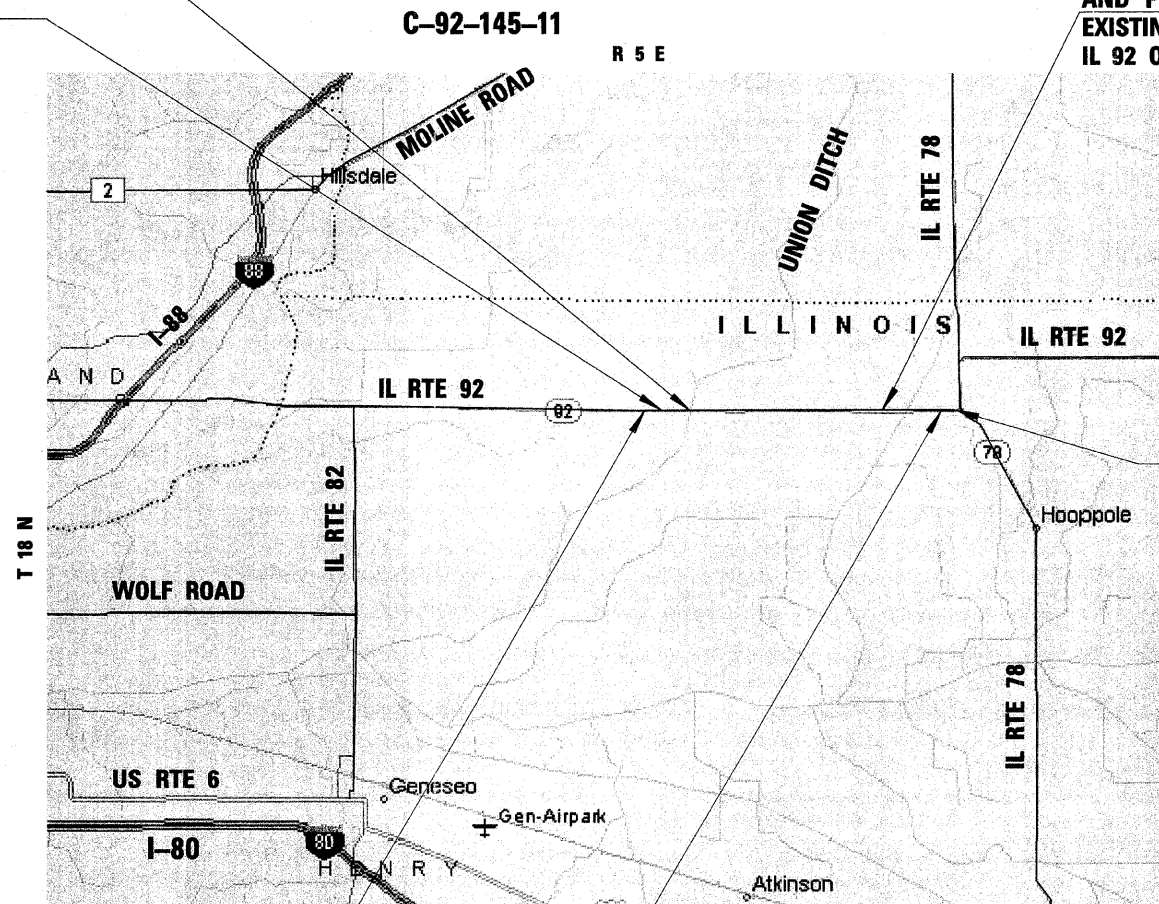

IMPROVEMENT BEGINS
STA. 619 + 70.00

SECTION ENDS
STA. 667 + 00.00

1" = 0.27 MI.

GROSS LENGTH = 4,550 FEET = 0.86 MILES
NET LENGTH = 2,550 FEET = 0.48 MILES



STATE OF ILLINOIS
DEPARTMENT OF TRANSPORTATION
DIVISION OF HIGHWAYS

SUBMITTED July 22 2011
Eric S. Threlkeld
DEPUTY DIRECTOR OF HIGHWAYS, REGION ENGINEER

August 19 2011
Scott E. Sitt, P.E.
ENGINEER OF DESIGN AND ENVIRONMENT

August 19 2011
Christine M. Rodler
DIRECTOR OF HIGHWAYS, CHIEF ENGINEER

**PRINTED BY THE AUTHORITY
OF THE STATE OF ILLINOIS**

CONSULTANT: STRAND ASSOCIATES, INC. (815) 744-4200 ANTHONY J. STANDISH, P.E., S.E. 815-744-4200

INDEX OF SHEETS

- 1 COVER SHEET
- 2 INDEX OF SHEETS AND STANDARDS
- 3-4 GENERAL NOTES
- 5-6 SUMMARY OF QUANTITIES
- 7-13 TYPICAL SECTIONS
- 14-16 SCHEDULE OF QUANTITIES
- 17 HORIZONTAL AND VERTICAL CONTROLS
- 18-25 PLAN AND PROFILE SHEETS
- 26-35 STAGING SHEETS
- 36-38 EROSION CONTROL SHEETS
- 39-44* RIGHT-OF-WAY SHEETS
- 45-64 STRUCTURAL SHEETS
- 65-67 CULVERT DETAILS
- 68 DETAIL OF HOT-MIX ASPHALT SHOULDER AT GUARD RAIL (23.4)
- 68 HOT-MIX ASPHALT SHOULDER (23.4a)
- 68 CONCRETE HEADWALLS FOR PIPE DRAINS (27.4)
- 68 DELINEATOR AND POST ORIENTATION (37.4)
- 69 TYPICAL BENCHING ON EXISTING EMBANKMENT (50.4)
- 69 LAND SECTION & REFERENCE MARKER (63.4)
- 69 STOP LINE SIGN FOR TEMPORARY SIGNALS (99.4)
- 70 FIELD TILE JUNCTION VAULTS 600 (24) AND 900 (36) DIA. (30.2)
- 70 INFORMATIONAL WARNING SIGN (FOR NARROW TRAVEL LANES) (39.2)
- 71 WITNESS MARKER & PERMANENT SURVEY MARKERS, TYPE II (66.2)
- 71 AUTOMATIC FLAP GATE (73.2)
- 72 NAME PLATE FOR CULVERTS (88.2)
- 72 ROUGH GROOVED SURFACE SIGN (91.2)
- 73 CONCRETE COLLARS FOR PIPE OR BOX CULVERT EXTENSIONS (33.1)
- 74-76 TYPICAL PAVEMENT MARKINGS (41.1)
- 77-106 CROSS SECTIONS
- HIGHWAY STANDARDS

* SHEETS 41-44 NOT USED

HIGHWAY STANDARDS

- 000001-06 STANDARD SYMBOLS, ABBREVIATIONS AND PATTERNS
- 001001-02 AREAS OF REINFORCEMENT BARS
- 001006 DECIMALS OF AN INCH AND OF A FOOT
- 280001-05 TEMPORARY EROSION CONTROL SYSTEMS
- 420401-08 BRIDGE APPROACH PAVEMENT CONNECTOR
- 515001-03 NAME PLATE FOR BRIDGES
- 542401-01 METAL END SECTION FOR PIPE CULVERT
- 601101-01 CONCRETE HEADWALL FOR PIPE DRAIN
- 630001-09 STEEL PLATE BEAM GUARDRAIL
- 630301-05 SHOULDER WIDENING FOR TYPE 1 (SPECIAL) GUARDRAIL TERMINALS
- 631031-09 TRAFFIC BARRIER TERMINAL, TYPE 6
- 635001-01 DELINEATORS
- 635006-03 REFLECTOR AND TERMINAL MARKER PLACEMENT
- 635011-02 REFLECTOR MARKER AND MOUNTING DETAILS
- 665001-02 WOVEN WIRE FENCE
- 666001-01 RIGHT-OF-WAY MARKERS
- 701001-02 OFF-ROAD OPERATIONS, 2L, 2W MORE THAN 15' AWAY
- 701006-03 OFF-ROAD OPERATIONS, 2L, 2W, 15'(4.5M) TO 24'(600MM) FROM PAVEMENT EDGE
- 701011-02 OFF-ROAD MOVING OPERATIONS, 2L, 2W, DAY ONLY
- 701201-04 LANE CLOSURE 2L, 2W, DAY ONLY, FOR SPEEDS \geq 45 MPH
- 701301-04 LANE CLOSURE, 2L, 2W, SHORT TIME OPERATIONS
- 701311-03 LANE CLOSURE 2L, 2W MOVING OPERATIONS-DAY ONLY
- 701321-11 LANE CLOSURE, 2L, 2W, BRIDGE REPAIR WITH BARRIER
- 701326-04 LANE CLOSURE, 2L, 2W, PAVEMENT WIDENING, FOR SPEEDS \geq 45 MPH
- 701901-01 TYPICAL CONTROL DEVICES
- 704001-06 TEMPORARY CONCRETE BARRIER
- 720011-01 METAL POSTS FOR SIGNS, MARKERS & DELINEATORS
- 728001-01 APPLICATIONS OF TYPES A & B METAL POSTS (FOR SIGNS & MARKERS)
- 729001-01 BASE FOR TELESCOPING STEEL SIGN SUPPORT
- 780001-02 TYPICAL PAVEMENT MARKINGS
- 781001-03 TYPICAL APPLICATIONS RAISED REFLECTIVE PAVEMENT MARKERS

FILE NAME = S:\JOL\6300-6399\6346\027\Misc\SHA\int-index&standards.dgn

	1170 SOUTH HOUBOLT ROAD JOLIET, ILLINOIS 60431 (815) 744-4200	USER NAME = brianf	DESIGNED -	REVISED -	STATE OF ILLINOIS DEPARTMENT OF TRANSPORTATION	INDEX OF SHEETS AND STANDARDS	F.A.P. RTE.	SECTION	COUNTY	TOTAL SHEETS	SHEET NO.
	PLOT SCALE = 5.0000' / IN.	CHECKED -	REVISED -	585			128 BR	HENRY	106	2	
	PLOT DATE = 7/21/2011	DATE -	REVISED -	CONTRACT NO. 64C20							
	SCALE: AS SHOWN		SHEET NO. OF SHEETS				STA. TO STA.		FED. ROAD DIST. NO. ILLINOIS FED. AID PROJECT		

Rev.

1. SEE CROSS SECTIONS FOR SPECIAL DITCHES AND BACKSLOPES.
2. THE REMOVAL OF BITUMINOUS SURFACING LESS THAN 6 INCH THICKNESS NOT ON A RIGID TYPE BASE REMOVED IN CONJUNCTION WITH THE BASE SHALL BE REMOVED AS EARTH EXCAVATION. THE REMOVAL OF BITUMINOUS SURFACING ON A RIGID TYPE BASE OF A THICKNESS OF 6 INCHES OR MORE ON A FLEXIBLE BASE REMOVED IN CONJUNCTION WITH THE BASE SHALL BE INCLUDED IN THE CONTRACT UNIT PRICE FOR PAVEMENT REMOVAL OF THE TYPE SPECIFIED.
3. THE FINAL TOP 100 MM (FOUR INCHES) OF SOIL IN ANY RIGHT-OF-WAY AREA DISTURBED BY THE CONTRACTOR MUST BE CAPABLE OF SUPPORTING VEGETATION. THE SOIL MUST BE FROM THE A HORIZON (ZERO TO 2' DEEP) OF SOIL PROFILES OF LOCAL SOILS.
4. ALL BORROW/WASTE/USE SITES MUST BE APPROVED BY THE DEPARTMENT PRIOR TO REMOVING ANY MATERIAL FROM THE PROJECT OR INITIATING ANY EARTHMOVING ACTIVITIES, INCLUDING TEMPORARY STOCKPILING OUTSIDE THE LIMITS OF CONSTRUCTION.
5. THE CONTRACTOR SHALL SEED ALL DISTURBED AREAS WITHIN THE PROJECT LIMITS. SEEDING CLASS 4 OR 2A SHALL BE USED, EXCEPT IN FRONT OF PROPERTIES WHERE THE GRASS WILL BE MOWED, THEN USE SEEDING, CLASS 1. CLASS 2A SHALL BE USED ON FRONT SLOPES AND DITCH BOTTOMS. CLASS 4 SHALL BE USED BEHIND TYPE A GUTTER, ON ALL BACKSLOPES AND AREAS BEHIND THE BACKSLOPE, AND BEYOND THE TOE OF FRONT SLOPE ON FILL SECTIONS WITHOUT DITCHES.
6. THE FOLLOWING MIXTURE REQUIREMENTS ARE APPLICABLE FOR THIS PROJECT:

MIXTURE USES	SURFACE COURSE	LEVEL BINDER	SHOULDER SURFACE	SHOULDER BASE
PG:	PG 64-22	PG 64-22	PG 58-22	PG 58-22
DESIGN AIR VOIDS:	4.0% @ N DESIGN=50	4.0% @ N DESIGN=50	4.0% @ N DESIGN=50	2% @ N DESIGN=50
MIXTURE COMPOSITION (GRADATION MIXTURE)	IL-9.5 MM OR IL-12.5 MM	IL 9.5 MM	IL-9.5 MM OR IL-12.5 MM	BAM OR IL 19.0
FRICTION AGGREGATE	C	N/A	N/A	N/A
20 YEAR ESAL	0.9	0.9	0.9	N/A

7. THE CONTRACTOR WILL BE REQUIRED TO FURNISH 140 MM (5 1/2") HIGH BRASS STENCILS AS APPROVED BY THE ENGINEER AND INSTALL STATIONING AT 250' INTERVALS. STATIONING SHALL BE PLACED ON BOTH LANES OF 2-LANE HIGHWAYS AND ON THE OUTSIDE LANES IN BOTH DIRECTIONS ON 4-LANE HIGHWAYS. THE STATIONS SHALL BE PLACED 150 MM (6") INSIDE THE PAVEMENT MARKING EDGE SO THEY CAN BE READ FROM THE SHOULDER. THIS WORK WILL BE INCLUDED IN THE COST OF THE FINAL PAVEMENT SURFACE.
8. THE AREA TO BE PRIMED SHALL BE LIMITED TO THAT WHICH CAN BE COVERED WITH HMA THE SAME DAY, UNLESS OTHERWISE PERMITTED BY THE ENGINEER.
9. REFLECTIVE CRACK CONTROL SHALL BE PLACED ON THE EXISTING SURFACE PRIOR TO ANY RESURFACING, UNLESS PAVEMENT IS MILLED THEN IT WILL BE PLACED ON THE BINDER COURSE.
10. BITUMINOUS AND AGGREGATE PRIME COAT SHALL BE PLACED IN ACCORDANCE WITH SECTION 406 OF THE STANDARD SPECIFICATIONS. THE COST OF THE PRIME COATS SHALL BE INCLUDED IN THE CONTRACT UNIT PRICE PER METRIC TON (TON) FOR LEVELING BINDER (MACHINE METHOD) OF THE TYPE SPECIFIED.
11. A NATIONWIDE 404 PERMIT HAS BEEN ISSUED FOR THIS PROJECT AND THE CONDITIONS OF THAT PERMIT MUST BE ADHERED TO.
12. THE NEW NUMBER FOR THE STRUCTURE CARRYING IL 92 OVER MAIN UNION DITCH WILL BE 037-0174.
13. THE STRUCTURE CARRYING IL 92 OVER THE DRAINAGE DITCH WILL RETAIN THE SAME NUMBER 037-1184.
14. THE THICKNESS FOR THE BRIDGE APPROACH PAVEMENT CONNECTOR (FLEXIBLE) ADJACENT TO EXISTING PAVEMENT SHALL BE A MINIMUM OF 300 MM (12"). THE MATERIAL SHALL BE 50 MM (2") HOT-MIX ASPHALT SURFACE COURSE, AND THE REMAINING THICKNESS SHALL BE HOT-MIX ASPHALT BINDER COURSE.
15. REFLECTOR MARKERS TYPE B SHALL BE INSTALLED ON THE TOP OF BRIDGE PARAPET WALLS. THE MARKERS SHALL BE ACCORDING TO STANDARD 635011 AND THE COLOR AND SPACING ACCORDING TO STANDARD 635006, EXCEPT THE MINIMUM IS 2 PER SIDE.
16. THE BORING LOGS FOR THIS STRUCTURE INDICATE THAT GROUNDWATER LEVELS MAY ENCROACH ON THE CONSTRUCTION LIMITS OF THIS CULVERT. IT SHALL BE THE RESPONSIBILITY OF THE CONTRACTOR TO CONTROL THE GROUND WATER AND DIVERT THE STREAM FLOW DURING CONSTRUCTION IN ORDER TO KEEP THE CONSTRUCTION AREA FREE OF WATER. THE METHOD OF CONTROLLING THE WATER SHALL BE SUBJECT TO APPROVAL OF THE ENGINEER AND THE COST SHALL BE INCLUDED IN THE CONTRACT UNIT PRICE FOR END SECTIONS.

17. CULVERT & BRIDGE FLOWS MUST BE MAINTAINED THROUGHOUT THE PROJECT. NORMAL FLOW SHALL BE ALLOWED TO PASS AT THE RATE IT ENTERS THE JOBSITE. HIGH FLOWS SHALL BE ALLOWED TO PASS WITHOUT CAUSING DAMAGE TO UPSTREAM PROPERTIES.
18. THE CONTRACTOR SHALL CLEAN OUT ALL AR CULVERTS AND STREAM FLOWS TO THE RIGHT-OF-WAY LINES ON THE ENTIRE SECTION. THE COST SHALL BE INCLUDED IN THE CONTRACT UNIT PRICE FOR EARTH EXCAVATION.
19. IT IS ASSUMED THAT 4,000 CUBIC YARDS OF THE EXCAVATED MATERIAL FROM THE REALIGNMENT OF THE DRAINAGE DITCH CAN BE USED AS EMBANKMENT BY THE CONTRACTOR, AT THEIR DISCRETION, TO BALANCE THE EARTHWORK DURING THE VARIOUS SUGGESTED STAGES OF CONSTRUCTION.
20. CONNECTING BANDS FOR CORRUGATED METAL PIPES SHALL BE METAL AND SHALL BE COATED WITH THE SAME MATERIAL AS THE PIPE SECTIONS. THE CONNECTING BANDS SHALL BE A MINIMUM OF 18" WIDE.
21. WHERE FIELD TILE IS ENCOUNTERED, STORM SEWER OR PIPE DRAIN WILL BE USED IN ACCORDANCE WITH SECTION 611. THE MINIMUM SIZE FOR REPLACEMENT WILL BE 150 MM (6") FOR PIPE DRAINS AND 200 MM (8") FOR STORM SEWER, BUT THE SIZE MUST BE AT LEAST 50 MM (2") LARGER THAN THE ADJOINING TILE. A FIELD TILE JUNCTION VAULT WILL BE CONSTRUCTED AT THE RIGHT OF WAY TO CONNECT THE TILE AND STORM SEWER. SEE THE SUMMARY OF QUANTITIES FOR THE ESTIMATED QUANTITIES.
22. THE EXCAVATED MATERIALS FROM EARTH EXCAVATION WIDENING, GRADING AND SHAPING DITCHES, AND EXCAVATING AND GRADING SHOULDERS SHALL BE USED TO BUILD UP THE SHOULDER THROUGHOUT THE JOB TO CONFORM WITH THE TYPICAL SECTIONS AND SHOULDER WIDENING FOR TERMINALS AS SHOWN ON THE PLANS.
23. EMBANKMENT QUANTITIES FOR THE CONSTRUCTION OF THE TRAFFIC BARRIER TERMINALS AS SHOWN IN THE PLANS ARE INCLUDED IN QUANTITIES FOR EARTH EXCAVATION.
24. THE CONTRACTOR SHALL SUPPLY THE RESIDENT ENGINEER WITH THE MANUFACTURER'S INSTALLATION REQUIREMENTS FOR THE TYPE OF STEEL PLATE BEAM GUARDRAIL TERMINAL TYPE 1 SPECIAL (TANGENT) OR STEEL PLATE BEAM GUARDRAIL TERMINAL TYPE I SPECIAL (FLARED).
25. ONE 16D GALVANIZED NAIL SHALL BE USED TO TOE NAIL THE WOOD BLOCK OUT TO THE WOOD POST ON ALL TRAFFIC BARRIER TERMINAL TYPE I SPECIALS.
26. DELINEATORS SHALL BE INSTALLED AS SHOWN IN STANDARD 635001, EXCEPT THAT THE POST SHALL BE ROTATED 180 AND ONLY METAL-BACKED DELINEATORS SHALL BE PERMITTED. DELINEATORS SHALL BE PLACED AT THE ENDS OF APPROACH GUARDRAIL TERMINAL SECTIONS, AND AT EACH HEADWALL OR END SECTION OF AR CULVERTS. THIS WORK WILL BE PAID FOR AT THE CONTRACT UNIT PRICE EACH FOR DELINEATORS.
27. PAVEMENT MARKING SHALL BE DONE ACCORDING TO STANDARD 780001, EXCEPT AS FOLLOWS:
 1. ALL WORDS, SUCH AS ONLY, SHALL BE 2.4 M (8 FEET) HIGH.
 2. ALL NON-FREEWAY ARROWS SHALL BE THE LARGE SIZE.
 3. THE DISTANCE BETWEEN YELLOW NO-PASSING LINES SHALL BE 200 MM (8"), NOT 180 MM (7") AS SHOWN IN THE DETAIL OF TYPICAL LANE AND EDGE LINES.
28. PERMANENT SURVEY MARKERS, TYPE II, SHALL BE SET AT INTERVALS OF 1.6 KM (1 MILE) OR AS DIRECTED BY THE ENGINEER. BRIDGE OR CULVERT PROJECTS SHALL HAVE ONE SURVEY MARKER PLACED NEAR THE STRUCTURE. ESTIMATED: 2 EACH.
29. PERMANENT SURVEY MARKERS, TYPE II SHALL BE CAST-IN-PLACE AS SHOWN ON DISTRICT STANDARD 66.2. THE BOTTOM OF THE MARKER SHALL BE 5'-0" BELOW THE GROUND SURFACE.
30. THE CONTRACTOR SHALL SUBMIT TO THE ENGINEER A DESCRIPTION OF LOCATION, ELEVATION, AND COORDINATES FOR EACH PERMANENT SURVEY MARKER. THE HORIZONTAL AND VERTICAL COORDINATES MUST BE DERIVED BY GPS AND THE ELEVATION DERIVED BY A CLOSED LEVEL CIRCUIT. THE ENGINEER SHALL SUBMIT THIS INFORMATION TO THE SURVEY CREW.

STAGE 1	STAGE 2
STA. 621+67.04-	STA. 621+67.95-
STA. 629+28.21	STA. 629+36.25
31. THE TEMPORARY CONCRETE BARRIER SHALL BE ANCHORED TO THE PAVEMENT WITH 6 ANCHORS PER SECTION AT THE FOLLOWING LOCATIONS:
32. PREVIOUSLY PUGMILLED STOCKPILES OF "TYPE A" OLDER THAN 1 MONTH WILL NOT BE APPROVED FOR USE UNTIL A MOINTURE CHECK IS RUN TO VERIFY MOINTURE CONTENT. MATERIAL SHIPPED TO PROJECTS WITHOUT BEING TESTED WILL NOT BE ACCEPTED.

FILE NAME = st:\j01\6200-6399\6346\027\misc\ca\sh\sh\sh\gen\notes\dgn



USER NAME = brianf	DESIGNED -	REVISED -
PLOT SCALE = 20.0000 ' / IN.	DRAWN -	REVISED -
PLOT DATE = 7/19/2011	CHECKED -	REVISED -
	DATE -	REVISED -

**STATE OF ILLINOIS
DEPARTMENT OF TRANSPORTATION**

GENERAL NOTES

SCALE: AS SHOWN SHEET NO. OF SHEETS STA. TO STA.

F.A.P RTE.	SECTION	COUNTY	TOTAL SHEETS	SHEET NO.
585	128 BR	HENRY	106	3
CONTRACT NO. 64C20				
FED. ROAD DIST. NO. 2 ILLINOIS FED. AID PROJECT				

33. RIGHT-OF-WAY MARKERS WILL BE ERECTED WITH THE BACK FACE OF THE MARKER ON THE RIGHT-OF-WAY LINE UNLESS THE NEW RIGHT-OF-WAY LINE HAS BEEN SURVEYED AND PINNED, IN WHICH INSTANCE THE RIGHT-OF-WAY MARKERS WILL BE ERECTED 300 MM (12 INCHES) INSIDE THE NEW RIGHT-OF-WAY LINE.

34. THE CONTRACTOR SHALL BE RESPONSIBLE FOR PROTECTING UTILITY PROPERTY DURING CONSTRUCTION OPERATIONS AS OUTLINED IN ARTICLE 107.31 OF THE STANDARD SPECIFICATIONS. A MINIMUM OF 48 HOURS ADVANCE NOTICE IS REQUIRED FOR NON-EMERGENCY WORK. THE JULIE NUMBER IS 800-892-0123. THE FOLLOWING LISTED UTILITIES LOCATED WITHIN THE PROJECT LIMITS OR IMMEDIATELY ADJACENT TO THE PROJECT CONSTRUCTION LIMITS ARE MEMBERS OF JULIE:

NAME AND ADDRESS OF UTILITY	TYPE
AT&T COMMUNICATIONS, INC. MR. CARL DONAHUE 866 ROCK CREEK ROAD PLANO, IL 60545 (630)-552-4677	TELEPHONE
COMMONWEALTH EDISON COMPANY MR. MICHAEL LENOX 123 ENERGY AVE. ROCKFORD, IL 61109 (815)-490-2869	ELECTRIC
NICOR GAS CO. MS. CONSTANCE LANE 1844 FERRY ROAD NAPERVILLE, IL 60563-9600 (630)-983-8676	GAS
FRONTIER/CITIZENS MR. DAVID DAY 684 N. BROAD/P.O. BOX 12 LANARK, IL 61046	TELEPHONE

35. THE APPLICABLE PORTIONS OF ARTICLE 105.07 OF THE STANDARD SPECIFICATION SHALL APPLY EXCEPT FOR THE FOLLOWING: THE CONTRACTOR SHALL BE RESPONSIBLE TO LOCATE THE VERTICAL DEPTHS OF THE UNDERGROUND UTILITIES WHICH MAY INTERFERE WITH CONSTRUCTION OPERATIONS. THIS WORK WILL NOT BE MEASURED OR PAID FOR SEPARATELY, BUT SHALL BE CONSIDERED AS INCLUDED IN THE UNIT BID PRICE FOR THE ITEM OF CONSTRUCTION INVOLVED. PER SB 699 (90 DAY UTILITY RELOCATION LAW), ONCE RIGHT-OF-WAY IS CLEAR TO AWARD THE PROJECT, A NOTICE WILL BE SENT TO THE UTILITY COMPANIES INSTRUCTING THEM TO HAVE THEIR FACILITIES RELOCATED WITHIN 90 DAYS. ESTIMATED DATE RELOCATION COMPLETE = AWARD DATE + 100 DAYS.

36. CADD DATA WILL BE AVAILABLE TO CONTRACTORS AND CONSULTANTS WORKING ON THIS PROJECT. THIS INFORMATION WILL BE PROVIDED UPON REQUEST AS MICROSTATION CADD FILES AND GEOPAK COORDINATE GEOMETRY FILES ONLY. IF DATA IS REQUIRED IN OTHER FORMATS IT WILL BE YOUR RESPONSIBILITY TO MAKE THESE CONVERSIONS. IF ANY DISCREPANCY OR INCONSISTENCY ARISES BETWEEN THE ELECTRONIC DATA AND THE INFORMATION ON THE HARD COPY, THE INFORMATION ON THE HARD COPY SHOULD BE USED. CONTACT THE DISTRICT'S PROJECT ENGINEER TO REQUEST THESE FILES.

37. TEMPORARY IMPACT ATTENUATORS THAT HAVE BEEN FURNISHED AND PLACED COULD BE RELOCATED ON THE SAME PROJECT. THE ATTENUATORS RELOCATED, FROM ONE STAGE TO ANOTHER, FROM THE PROJECT TO AN OFFSITE LOCATION, OR FROM THE OFFSITE LOCATION BACK TO THE PROJECT, WILL BE PAID FOR AT THE CONTRACT UNIT PRICE PER EACH FOR IMPACT ATTENUATORS RELOCATE OF THE PARTICULAR TYPE SPECIFIED.

38. TEMPORARY CONCRETE BARRIER THAT HAS BEEN FURNISHED AND PLACED COULD BE RELOCATED ON THE SAME PROJECT. THE TEMPORARY CONCRETE BARRIER RELOCATED, FROM ONE STAGE TO ANOTHER, FROM THE PROJECT TO AN OFFSITE LOCATION, OR FROM THE OFFSITE LOCATION BACK TO THE PROJECT, WILL BE PAID FOR AT THE CONTRACT UNIT PRICE PER FOOT FOR RELOCATE TEMPORARY CONCRETE BARRIER.

39. THE CONTRACTOR SHALL BEGIN FENCE ERECTION AS SOON AS CLEARING OPERATIONS PERMIT. BEFORE REMOVING EXISTING FENCE FROM AN AREA THAT CONTAINS LIVESTOCK, THE CONTRACTOR SHALL ERECT, ALONG THE PROPOSED RIGHT OF WAY LINES, A TEMPORARY FENCE OR WIRE MEETING THE APPROVAL OF THE ENGINEER. THE CONTRACTOR SHALL CONCENTRATE HIS PERMANENT FENCING OPERATIONS AT THESE LOCATIONS AND AT OTHER SPECIFIED LOCATIONS AS DIRECTED BY THE ENGINEER. THE COST OF ARRANGING WORK AS HEREIN SPECIFIED AND ERECTING ANY TEMPORARY FENCING WILL NOT BE PAID FOR AS A SEPARATE ITEM BUT SHALL BE INCLUDED IN THE CONTRACT UNIT PRICE PER METER (FOOT) FOR WOVEN WIRE FENCE AND/OR CHAIN LINK FENCE.

40. THE CONTRACTOR SHALL CONTACT IDOT DISTRICT 2 MAINTENANCE FIELD ENGINEER MS. TRISHA THOMPSON (815 284 5408) PRIOR TO REMOVING THE GUARDRAIL ON ANY SECTION OF THE PROJECT.

41. REMOVAL AND DISPOSAL OF UNSUITABLE MATERIAL (500 CUBIC YARDS) HAS BEEN PROVIDED IN THE CONTRACT. THE ACTUAL NEED FOR THIS WORK SHALL BE DETERMINED IN THE FIELD BY THE ENGINEER.

FILE NAME = s:\j\6300-6399\6346\027\microra\sh\sh-gennot.e2.dgn

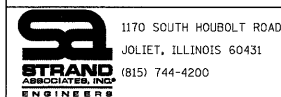

1170 SOUTH HOUBOLT ROAD JOLIET, ILLINOIS 60431 (815) 744-4200	USER NAME = brianf	DESIGNED -	REVISED -
	PLOT SCALE = 28,0000 ' / IN.	DRAWN -	REVISED -
	PLOT DATE = 7/19/2011	CHECKED -	REVISED -
		DATE -	REVISED -

**STATE OF ILLINOIS
DEPARTMENT OF TRANSPORTATION**

GENERAL NOTES

SCALE: AS SHOWN SHEET NO. OF SHEETS STA. TO STA.

F.A.P RTE.	SECTION	COUNTY	TOTAL SHEETS	SHEET NO.
585	128 BR	HENRY	106	4
CONTRACT NO. 64C20				
FED. ROAD DIST. NO. 2 ILLINOIS FED. AID PROJECT				

NUMBER	ITEM	UNIT	TOTAL	80% FED 20% STATE ROADWAY 0005	SN 037-0174 80% FED 20% STATE 0011	037-1184 80% FED 20% STATE 0040
20200100	EARTH EXCAVATION	CU YD	15,465	15,465		
20201200	REMOVAL AND DISPOSAL OF UNSUITABLE MATERIAL	CU YD	500	500		
21101615	TOPSOIL FURNISH AND PLACE, 4"	SQ YD	23,700	23,700		
25000210	SEEDING, CLASS 2A	ACRE	2.75	2.75		
25000310	SEEDING, CLASS 4	ACRE	2.5	2.5		
25000400	NITROGEN FERTILIZER NUTRIENT	POUND	250	250		
25000500	PHOSPHORUS FERTILIZER NUTRIENT	POUND	250	250		
25000600	POTASSIUM FERTILIZER NUTRIENT	POUND	250	250		
& 25000750	MOWING	ACRE	2.75	2.75		
25100115	MULCH, METHOD 2	ACRE	2.75	2.75		
25100630	EROSION CONTROL BLANKET	SQ YD	7,635	7,635		
25100900	TURF REINFORCEMENT MAT	SQ YD	676	676		
28000250	TEMPORARY EROSION CONTROL SEEDING	POUND	3,600	3,600		
28000305	TEMPORARY DITCH CHECKS	FOOT	100	100		
28000400	PERIMETER EROSION BARRIER	FOOT	1,337	1,337		
28000500	INLET AND PIPE PROTECTION	EACH	2	2		
28100109	STONE RIPRAP, CLASS A5	SQ YD	608		608	
28200200	FILTER FABRIC	SQ YD	1,097	489	608	
28500400	ARTICULATED BLOCK REVETMENT MAT	SQ YD	489	489		
31100910	SUBBASE GRANULAR MATERIAL, TYPE A 12"	SQ YD	832	832		
40200800	AGGREGATE SURFACE COURSE, TYPE B	TON	45	45		
40600625	LEVELING BINDER (MACHINE METHOD), N50	TON	81	81		
40600982	HOT-MIX ASPHALT SURFACE REMOVAL - BUTT JOINT	SQ YD	260	260		
40603310	HOT-MIX ASPHALT SURFACE COURSE, MIX "C", N50	TON	216	216		
42001430	BRIDGE APPROACH PAVEMENT CONNECTOR (FLEXIBLE)	SQ YD	64	64		
44000100	PAVEMENT REMOVAL	SQ YD	304	304		
44300200	STRIP REFLECTIVE CRACK CONTROL TREATMENT	FOOT	337	337		
48203023	HOT-MIX ASPHALT SHOULDERS, 6 1/2"	SQ YD	1,736	1,736		
50100100	REMOVAL OF EXISTING STRUCTURES	EACH	1		1	
50100300	REMOVAL OF EXISTING STRUCTURES NO. 1	EACH	1			1
50105220	PIPE CULVERT REMOVAL	FOOT	440	440		
50200100	STRUCTURE EXCAVATION	CU YD	426		426	
50300100	FLOOR DRAINS	EACH	12		12	
50300225	CONCRETE STRUCTURES	CU YD	79		79	
50300255	CONCRETE SUPERSTRUCTURE	CU YD	299		299	
50300260	BRIDGE DECK GROOVING	SQ YD	643		643	
50300280	CONCRETE ENCASMENT	CU YD	6		6	
50300300	PROTECTIVE COAT	SQ YD	810		810	

NUMBER	ITEM	UNIT	TOTAL	80% FED 20% STATE ROADWAY 0005	SN 037-0174 80% FED 20% STATE 0011	037-1184 80% FED 20% STATE 0040
50500105	FURNISHING AND ERECTING STRUCTURAL STEEL	L SUM	1		1	
50500505	STUD SHEAR CONNECTORS	EACH	3,204		3,204	
50800205	REINFORCEMENT BARS, EPOXY COATED	POUND	84,920		77,800	7,120
50800515	BAR SPLICERS	EACH	1,004		1,004	
51201600	FURNISHING STEEL PILES HP12X53	FOOT	1,316		1,316	
51202305	DRIVING PILES	FOOT	1,316		1,316	
51203600	TEST PILE STEEL HP12X53	EACH	2		2	
51500100	NAME PLATES	EACH	1		1	
52100520	ANCHOR BOLTS, 1"	EACH	24		24	
54001001	BOX CULVERT END SECTIONS, CULVERT NO. 1	EACH	2			2
54215559	METAL END SECTIONS 24"	EACH	2	2		
54248510	CONCRETE COLLAR	CU YD	3.7			3.7
542D1069	PIPE CULVERTS, CLASS D, TYPE 2 24"	FOOT	159	159		
59100100	GEOCOMPOSITE WALL DRAIN	SQ YD	100		100	
60100915	PIPE DRAINS 6"	FOOT	100	100		
60801024	FLAP GATE 24"	EACH	2	2		
61133100	FIELD TILE JUNCTION VAULTS, 2' DIA.	EACH	4	4		
# 63000001	STEEL PLATE BEAM GUARDRAIL, TYPE A, 6 FOOT POSTS	FOOT	200	200		
# 63100085	TRAFFIC BARRIER TERMINAL, TYPE 6	EACH	4	4		
# 63100167	TRAFFIC BARRIER TERMINAL, TYPE 1 (SPECIAL) TANGENT	EACH	3	3		
# 63100169	TRAFFIC BARRIER TERMINAL, TYPE 1 (SPECIAL) FLARED	EACH	1	1		
63200310	GUARDRAIL REMOVAL	FOOT	386	386		
63500105	DELINEATORS	EACH	6	6		
66500105	WOVEN WIRE FENCE, 4'	FOOT	102	102		
66600105	FURNISHING AND ERECTING RIGHT OF WAY MARKERS	EACH	20	20		
66700305	PERMANENT SURVEY MARKERS, TYPE II	EACH	2	2		
67000400	ENGINEER'S FIELD OFFICE, TYPE A	CAL MO	7	7		
67100100	MOBILIZATION	L SUM	1	1		
70100405	TRAFFIC CONTROL AND PROTECTION, STANDARD 701321	EACH	1	1		
70100450	TRAFFIC CONTROL AND PROTECTION, STANDARD 701201	L SUM	1	1		
70100500	TRAFFIC CONTROL AND PROTECTION, STANDARD 701326	L SUM	1	1		
70103815	TRAFFIC CONTROL SURVEILLANCE	CAL DA	10	10		
70106500	TEMPORARY BRIDGE TRAFFIC SIGNALS	EACH	1	1		
70300100	SHORT TERM PAVEMENT MARKING	FOOT	174	174		
70300220	TEMPORARY PAVEMENT MARKING - LINE 4"	FOOT	3,803	3,803		
70300280	TEMPORARY PAVEMENT MARKING - LINE 24"	FOOT	24	24		
70301000	WORK ZONE PAVEMENT MARKING REMOVAL	SQ FT	1,359	1,359		
70400100	TEMPORARY CONCRETE BARRIER	FOOT	800	800		

SPECIALTY ITEMS
& NON PARTICIPATING - 100% STATE

FILE NAME = S:\JUL_15\3089-63799\6346\027\MicroStation\Sheet\S001.dgn

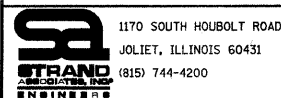

1170 SOUTH HOUBOLT ROAD JOLIET, ILLINOIS 60431 (815) 744-4200	USER NAME = raymondk PLOT SCALE = 20.0000' / 1" IN. PLOT DATE = 7/21/2011	DESIGNED - DRAWN - CHECKED - DATE -	REVISED - REVISED - REVISED - REVISED -
---	---	--	--

STATE OF ILLINOIS
DEPARTMENT OF TRANSPORTATION

SUMMARY OF QUANTITIES

SCALE: AS SHOWN SHEET NO. OF SHEETS STA. TO STA.

F.A.P RTE. 585	SECTION 128 BR	COUNTY HENRY	TOTAL SHEETS 106	SHEET NO. 5
FED. ROAD DIST. NO. 2 ILLINOIS FED. AID PROJECT				

CONTRACT NO. 64C20

	NUMBER	ITEM	UNIT	TOTAL	80% FED 20% STATE ROADWAY 0005	SN 037-0174 80% FED 20% STATE 0011	037-1184 80% FED 20% STATE 0040
	70400200	RELOCATE TEMPORARY CONCRETE BARRIER	FOOT	800	800		
#	78001110	PAINT PAVEMENT MARKING - LINE 4"	FOOT	3,874	3,874		
#	78100100	RAISED REFLECTIVE PAVEMENT MARKER	EACH	13	13		
#	78200410	GUARDRAIL MARKERS, TYPE A	EACH	16	16		
#	78200520	BARRIER WALL MARKERS, TYPE B	EACH	8	8		
#	78201000	TERMINAL MARKER - DIRECT APPLIED	EACH	4	4		
	78300100	PAVEMENT MARKING REMOVAL	SQ FT	639	639		
	78300200	RAISED REFLECTIVE PAVEMENT MARKER REMOVAL	EACH	14	14		
	X2070304	POROUS GRANULAR EMBANKMENT, SPECIAL	CU YD	199		199	
	X4400110	TEMPORARY PAVEMENT REMOVAL	SQ YD	657	657		
	X4401198	HOT-MIX ASPHALT SURFACE REMOVAL, VARIABLE DEPTH	SQ YD	469	469		
	Z0013798	CONSTRUCTION LAYOUT	L SUM	1	1		
	Z0020900	ESTABLISHING AND REFERENCING LAND SECTION MARKERS	EACH	2	2		
	Z0026407	TEMPORARY SHEET PILING	SQ FT	1,370		1,370	
	Z0030250	IMPACT ATTENUATORS, TEMPORARY (NON- REDIRECTIVE), TEST LEVEL 3	EACH	2	2		
	Z0030350	IMPACT ATTENUATORS, RELOCATE (NON- REDIRECTIVE), TEST LEVEL 3	EACH	2	2		
	Z0046304	PIPE UNDERDRAINS FOR STRUCTURES 4"	FOOT	167		167	
	Z0062456	TEMPORARY PAVEMENT	SQ YD	657	657		

SPECIALTY ITEMS
& NON PARTICIPATING - 100% STATE

FILE NAME = S:\JOL\6390-6399\6246\027\MicroStation\Shr\int-S002.dgn



1170 SOUTH HOUBOLT ROAD
JOLIET, ILLINOIS 60431
(815) 744-4200

USER NAME = raymondk	DESIGNED -	REVISED -
PLOT SCALE = 20.0000' / 1" IN.	DRAWN -	REVISED -
PLOT DATE = 7/21/2011	CHECKED -	REVISED -
	DATE -	REVISED -

STATE OF ILLINOIS
DEPARTMENT OF TRANSPORTATION

SUMMARY OF QUANTITIES

SCALE: AS SHOWN SHEET NO. OF SHEETS STA. TO STA.

F.A.P RTE.	SECTION	COUNTY	TOTAL SHEETS	SHEET NO.
585	128 BR	HENRY	106	6
FED. ROAD DIST. NO. 2 [ILLINOIS] FED. AID PROJECT				
CONTRACT NO. 64C20				

TYPICAL SECTIONS

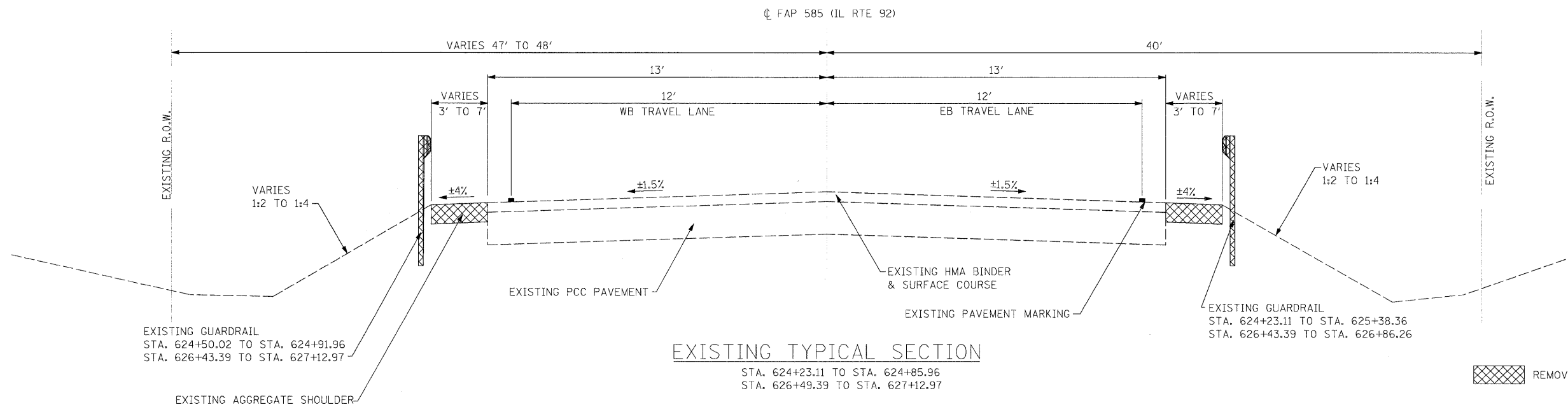
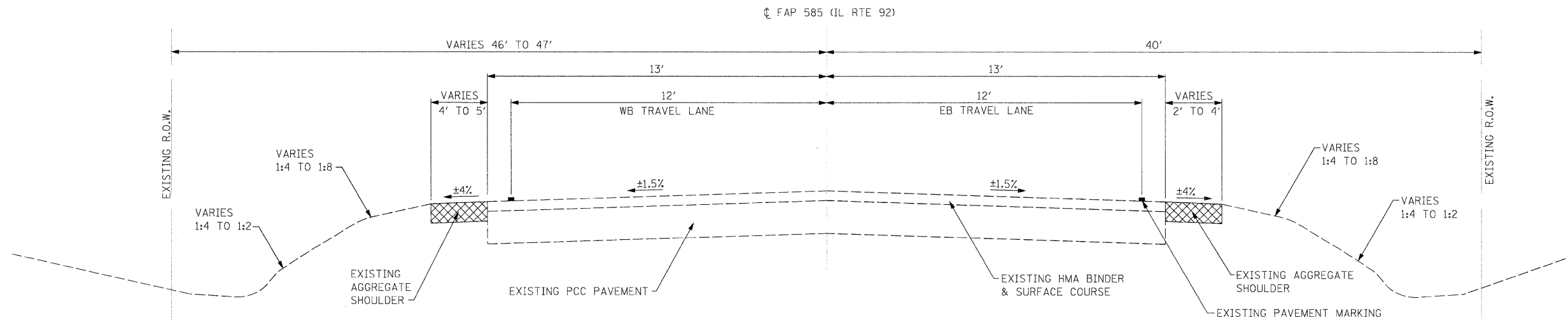

FILE NAME = s:\p1\6346-6395\6346\027\microos\sh1\sh1-typical1.dgn



1170 SOUTH HOUBOLT ROAD JOLIET, ILLINOIS 60431 (815) 744-4200	USER NAME = br1anf	DESIGNED -	REVISED -
	PLOT SCALE = 20,000' / IN.	DRAWN -	REVISED -
	PLOT DATE = 7/19/2011	CHECKED -	REVISED -
		DATE -	REVISED -

**STATE OF ILLINOIS
DEPARTMENT OF TRANSPORTATION**

EXISTING TYPICAL SECTIONS - BRIDGE			
SCALE: AS SHOWN	SHEET NO.	OF	SHEETS
STA.	TO STA.		

F.A.P. RTE.	SECTION	COUNTY	TOTAL SHEETS	SHEET NO.
585	128 BR	HENRY	106	7
CONTRACT NO. 64C20				
FED. ROAD DIST. NO. 2 ILLINOIS FED. AID PROJECT				

TYPICAL SECTIONS

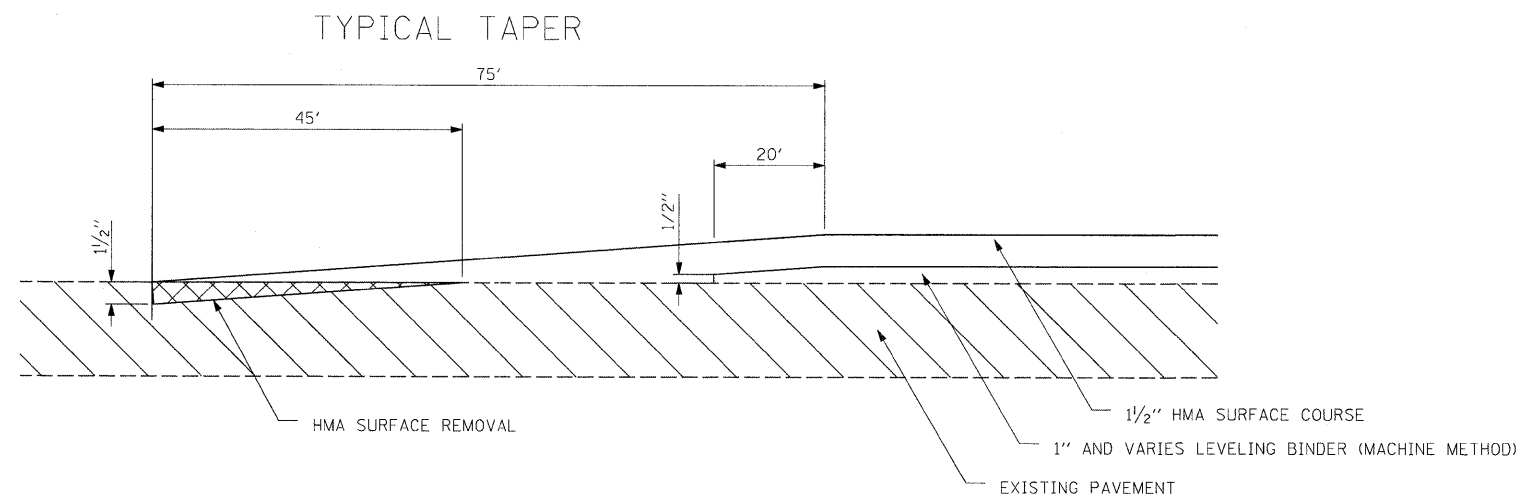
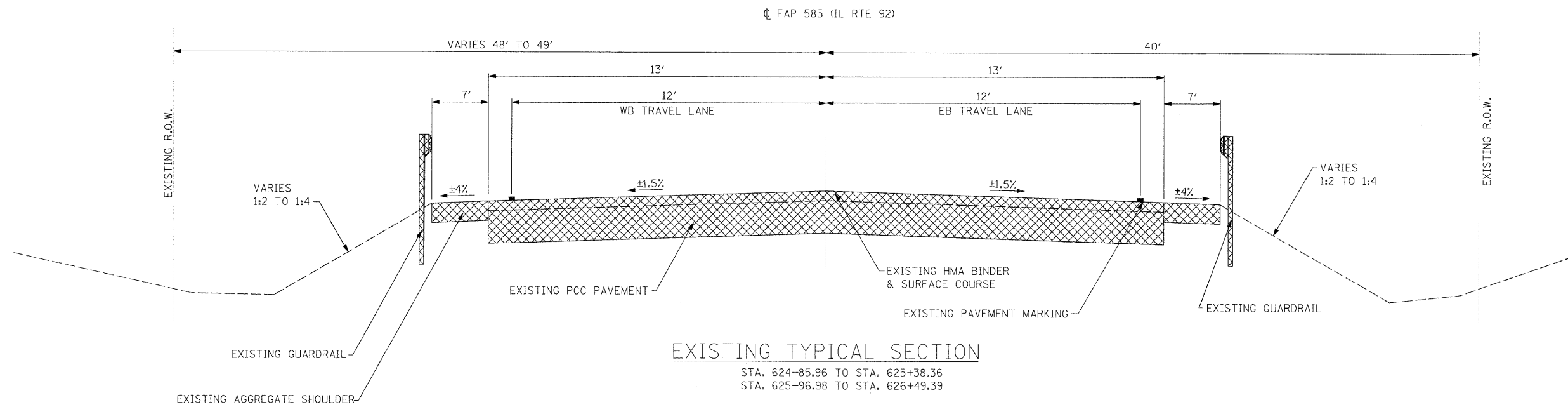

TYPICAL BUTT JOINT DETAIL

REMOVAL ITEMS

FILE NAME = s:\j\16302--6399\6346\027\misc\shh\shh\shh\typical.dgn

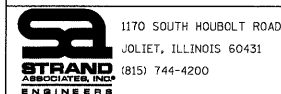

USER NAME = brianf	DESIGNED -	REVISED -
PLOT SCALE = 20.0000' / 1"	DRAWN -	REVISED -
PLOT DATE = 7/19/2011	CHECKED -	REVISED -
	DATE -	REVISED -

STATE OF ILLINOIS
DEPARTMENT OF TRANSPORTATION

EXISTING TYPICAL SECTIONS - BRIDGE

SCALE: AS SHOWN SHEET NO. OF SHEETS STA. TO STA.

F.A.P. RTE.	SECTION	COUNTY	TOTAL SHEETS	SHEET NO.
585	128 BR	HENRY	106	8
CONTRACT NO. 64C20				
FED. ROAD DIST. NO. 2 ILLINOIS FED. AID PROJECT				

TYPICAL SECTIONS

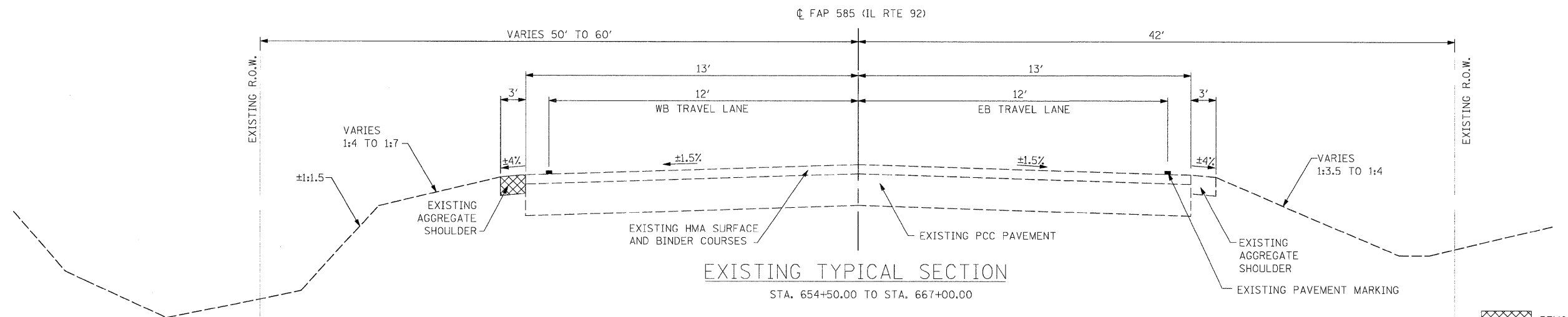
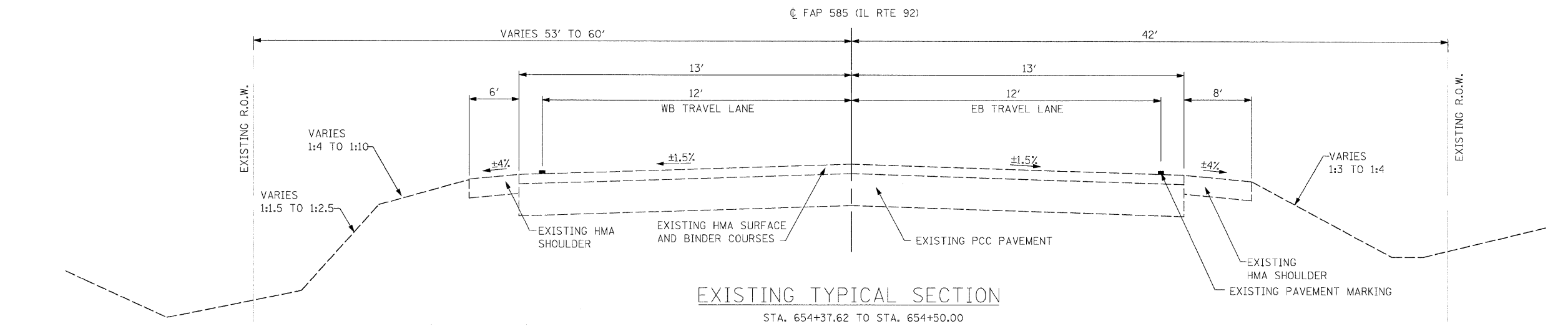
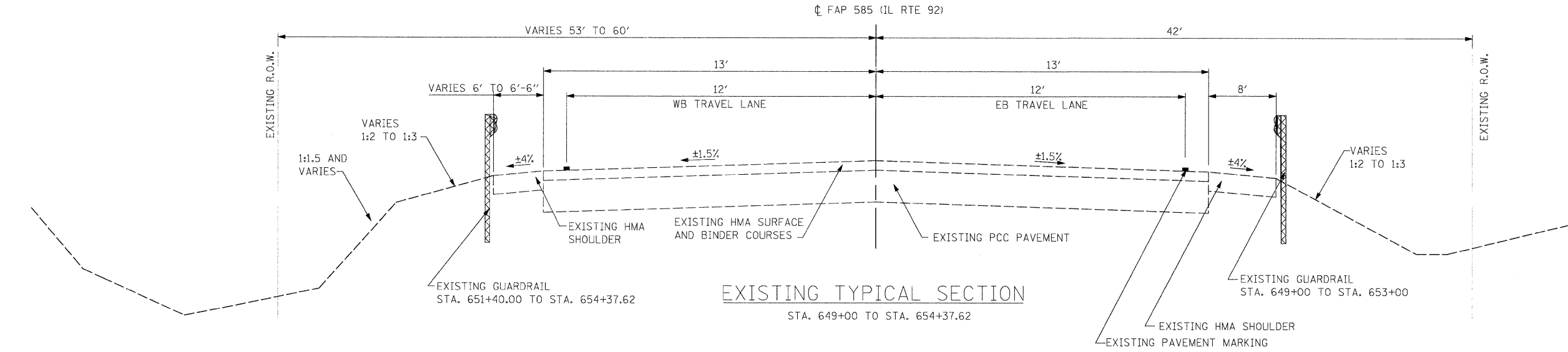

REMOVAL ITEMS

FILE NAME = s:\p1\6300-6399\6546\027\mcrs\shd\shd-typical.dgn



1170 SOUTH HOUBOLT ROAD JOLIET, ILLINOIS 60431 (815) 744-4200	USER NAME = brianf	DESIGNED -	REVISED -
PLOT SCALE = 28,0000' / IN.	CHECKED -	REVISED -	REVISED -
PLOT DATE = 7/19/2011	DATE -	REVISED -	REVISED -

**STATE OF ILLINOIS
DEPARTMENT OF TRANSPORTATION**

TYPICAL SECTION - CULVERT /DITCH			
SCALE: AS SHOWN	SHEET NO.	OF SHEETS	STA. TO STA.

F.A.P. RTE. 585	SECTION 128 BR	COUNTY HENRY	TOTAL SHEETS 106	SHEET NO. 9
FED. ROAD DIST. NO. 2 ILLINOIS FED. AID PROJECT				
CONTRACT NO. 64C20				

TYPICAL SECTIONS

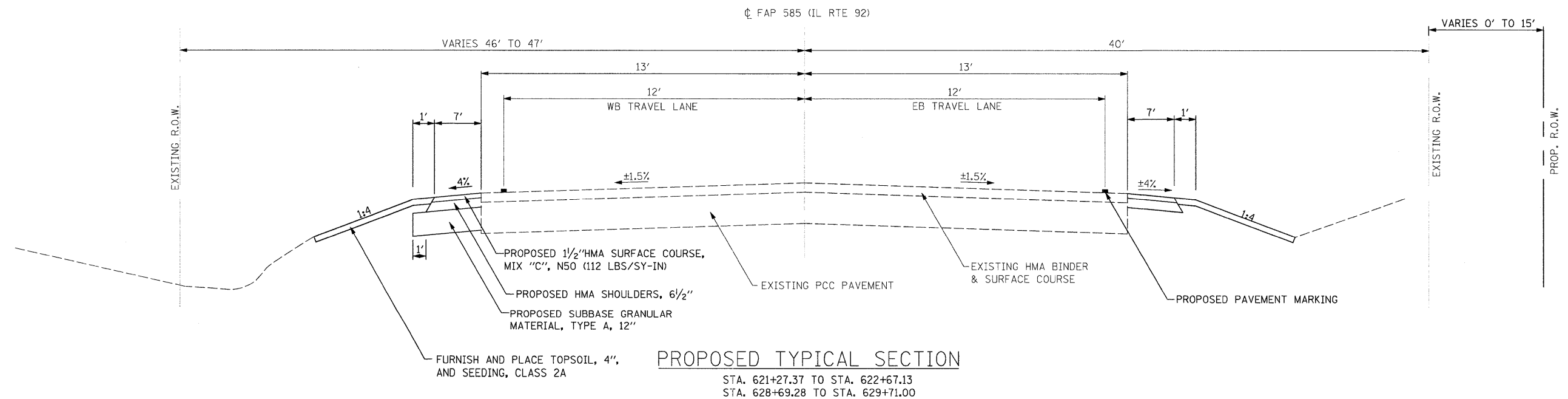
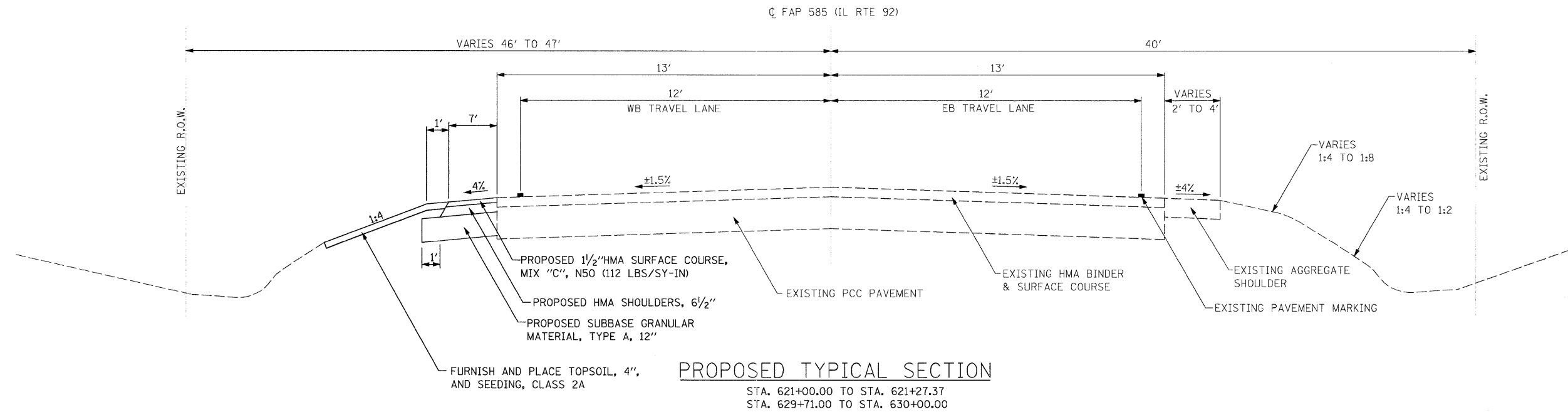

FILE NAME = s:\p1\63802-63945\6346\027\micron\sh\sh\typical2.dgn

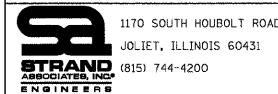

USER NAME = brianf	DESIGNED -	REVISED -
PLOT SCALE = 20.0000' / IN.	DRAWN -	REVISED -
PLOT DATE = 7/19/2011	CHECKED -	REVISED -
	DATE -	REVISED -

STATE OF ILLINOIS
DEPARTMENT OF TRANSPORTATION

TYPICAL SECTIONS - BRIDGE			
SCALE: AS SHOWN	SHEET NO.	OF SHEETS	STA. TO STA.

F.A.P. RTE. 585	SECTION 128 BR	COUNTY HENRY	TOTAL SHEETS 106	SHEET NO. 10
CONTRACT NO. 64C20				
FED. ROAD DIST. NO. 2 ILLINOIS FED. AID PROJECT				

TYPICAL SECTIONS

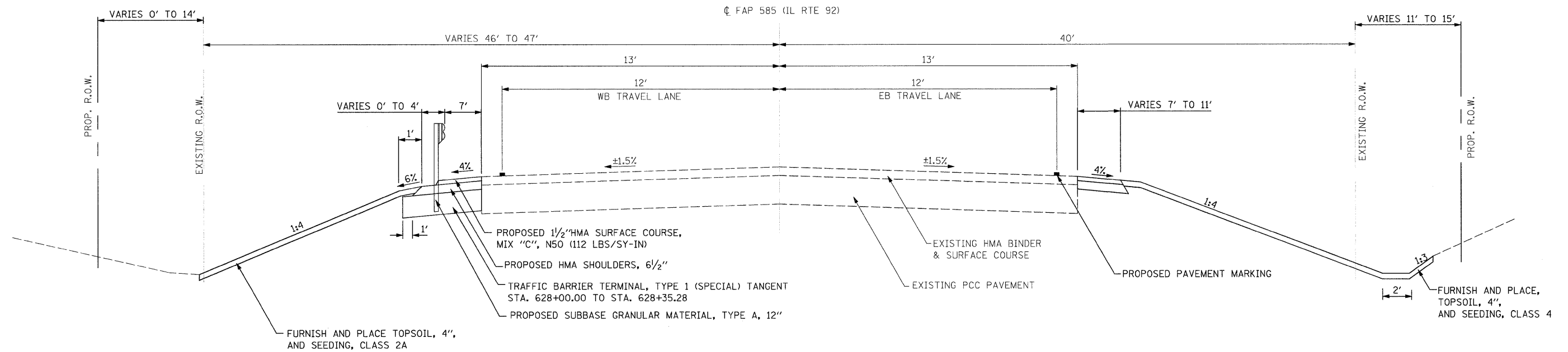

PROPOSED TYPICAL SECTION

STA. 622+67.13 TO STA. 623+00.00
 STA. 628+00.00 TO STA. 628+69.28

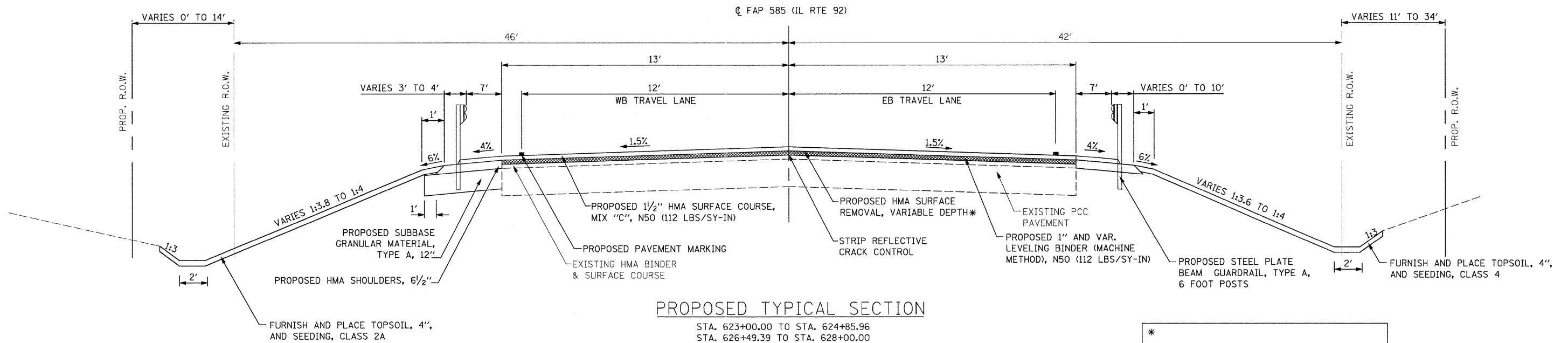

PROPOSED TYPICAL SECTION

STA. 623+00.00 TO STA. 624+85.96
 STA. 626+49.39 TO STA. 628+00.00

* SEE SCHEDULE OF QUANTITIES FOR LIMITS OF HMA SURFACE REMOVAL, VARIABLE DEPTH.

FILE NAME = s:\p1\63808-639\F6346\27\mroad\hst\typsec12.dgn



1170 SOUTH HOUBOLT ROAD JOLIET, ILLINOIS 60431 (815) 744-4200	USER NAME = brianf	DESIGNED -	REVISED -
	PLOT SCALE = 20.0000' / IN.	DRAWN -	REVISED -
	PLOT DATE = 7/19/2011	CHECKED -	REVISED -
		DATE -	REVISED -

**STATE OF ILLINOIS
 DEPARTMENT OF TRANSPORTATION**

TYPICAL SECTIONS - BRIDGE			
SCALE: AS SHOWN	SHEET NO.	OF SHEETS	STA. TO STA.

F.A.P. RTE. 585	SECTION 128 BR	COUNTY HENRY	TOTAL SHEETS 106	SHEET NO. 11
CONTRACT NO. 64C20				
FED. ROAD DIST. NO. 2 [ILLINOIS] FED. AID PROJECT				

TYPICAL SECTIONS

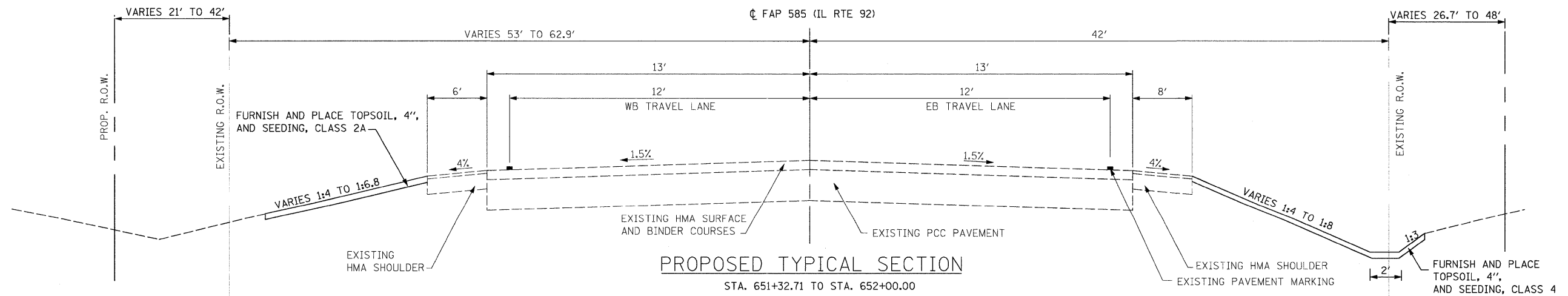
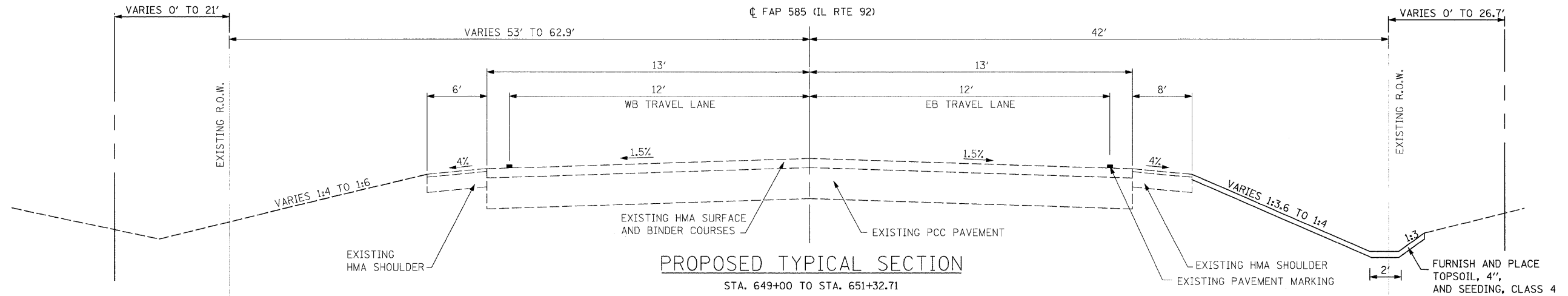

FILE NAME = s:_joi\6390-6399\6346\227\microsof\sh\typical2.dgn



USER NAME = brisnf	DESIGNED -	REVISED -
PLDT SCALE = 20.0000' / IN.	DRAWN -	REVISED -
PLDT DATE = 7/19/2011	CHECKED -	REVISED -
	DATE -	REVISED -

**STATE OF ILLINOIS
DEPARTMENT OF TRANSPORTATION**

TYPICAL SECTION - CULVERT /DITCH

SCALE: AS SHOWN SHEET NO. OF SHEETS STA. TO STA.

F.A.P. RTE.	SECTION	COUNTY	TOTAL SHEETS	SHEET NO.
585	128 BR	HENRY	106	12
CONTRACT NO. 64C20				
FED. ROAD DIST. NO. 2 ILLINOIS FED. AID PROJECT				

TYPICAL SECTIONS

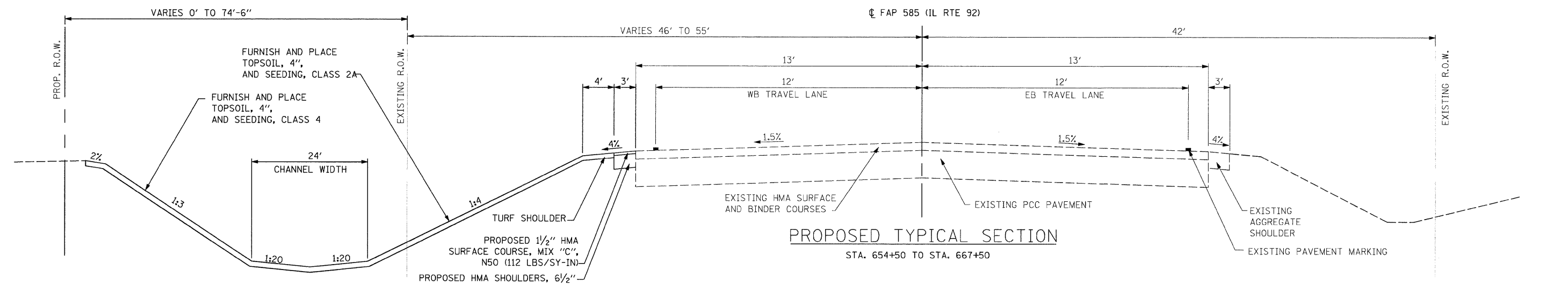
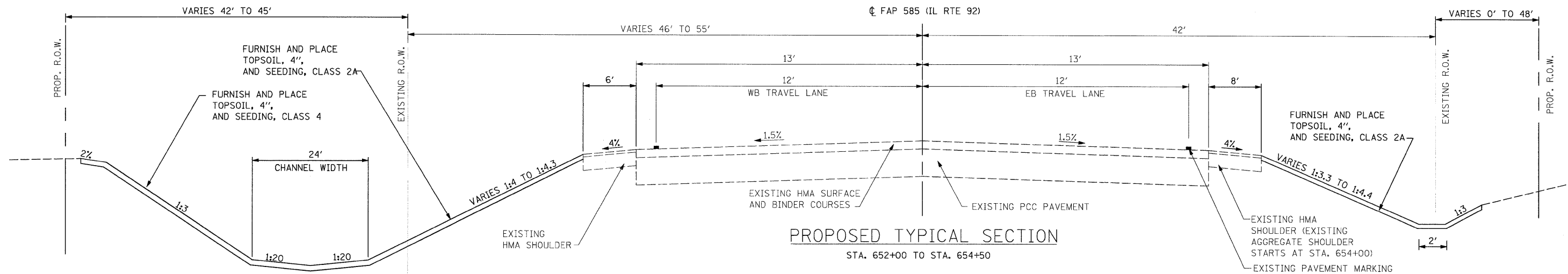

FILE NAME = s:\p1\6300--6399\6346\027\microsa\shht\shht-typical2.dgn



USER NAME = brienf	DESIGNED -	REVISED -
PLOT SCALE = 20,0000 ' / IN.	DRAWN -	REVISED -
PLOT DATE = 7/19/2011	CHECKED -	REVISED -
	DATE -	REVISED -

**STATE OF ILLINOIS
DEPARTMENT OF TRANSPORTATION**

TYPICAL SECTION - CULVERT /DITCH				
SCALE: AS SHOWN	SHEET NO.	OF	SHEETS	STA. TO STA.

F.A.P. RTE. 585	SECTION 128 BR	COUNTY HENRY	TOTAL SHEETS 106	SHEET NO. 13
CONTRACT NO. 64C20				
FED. ROAD DIST. NO. 2 ILLINOIS FED. AID PROJECT				

		EARTH EXCAVATION	EARTH EXCAVATION ADJUSTED FOR SHRINKAGE	EMBANKMENT	EARTHWORK BALANCE WASTE (+) OR SHORTAGE (-)
		CU YD	CU YD	CU YD	CU YD
STA. 620+50 TO 630+50	BRIDGE PRE-STAGE	150	115	325	-210
STA. 620+50 TO 630+50	BRIDGE STAGE 1	435	325	280	45
STA. 620+50 TO 630+50	BRIDGE STAGE 2	295	220	650	-430
STA. 648+50 TO 667+00	CULVERT/DITCH	14,585	10940	3,465	7,475
TOTAL		15,465			

• SEE GENERAL NOTE 19 FOR COMMENTS ON EARTHWORK BALANCE

21101615 TOPSOIL FURNISH AND PLACE, 4"					
STATION	OFF	TO	STATION	OFF	QUANTITY
	LT/RT			LT/RT	SY
620+50.00	LT		630+50.00	LT	1,400
620+50.00	RT		630+50.00	RT	1,650
648+50.00	LT/RT		667+00.00	LT/RT	20,650
TOTAL					23,700

25000210 SEEDING, CLASS 2A						
STATION	OFF	TO	STATION	OFF	AREA	QUANTITY
	LT/RT			LT/RT	SF	ACRE
621+00.00	RT		627+00.00	RT	10,510	0.29
621+00.00	LT		627+00.00	LT	7,554	0.21
627+00.00	RT		630+00.00	RT	5,668	0.16
627+00.00	LT		630+00.00	RT	4,672	0.13
649+00.00	RT		650+00.00	RT	829	0.02
650+00.00	RT		656+00.00	RT	7,186	0.20
650+00.00	LT		656+00.00	LT	17,314	0.48
656+00.00	LT		662+00.00	LT	23,525	0.65
662+00.00	LT		667+50.00	LT	21,641	0.60
TOTAL						2.72
ROUNDED TOTAL						2.75

25000310 SEEDING, CLASS 4						
STATION	OFF	TO	STATION	OFF	AREA	QUANTITY
	LT/RT			LT/RT	SF	ACRE
621+00.00	RT		627+00.00	RT	4,164	0.14
627+00.00	RT		630+00.00	RT	399	0.01
649+00.00	RT		650+00.00	RT	536	0.02
650+00.00	RT		656+00.00	RT	4,019	0.14
650+00.00	LT		656+00.00	LT	10,538	0.36
656+00.00	LT		662+00.00	LT	28,694	0.99
662+00.00	LT		667+50.00	LT	20,338	0.70
TOTAL						2.37
ROUNDED TOTAL						2.50

25100115 MULCH, METHOD 2						
STATION	OFF	TO	STATION	OFF	AREA	QUANTITY
	LT/RT			LT/RT	SF	ACRE
621+00.00	RT		627+00.00	RT	10,510	0.29
621+00.00	LT		627+00.00	LT	7,554	0.21
627+00.00	RT		630+00.00	RT	5,668	0.16
627+00.00	LT		630+00.00	RT	4,672	0.13
649+00.00	RT		650+00.00	RT	829	0.02
650+00.00	RT		656+00.00	RT	7,186	0.20
650+00.00	LT		656+00.00	LT	17,314	0.48
656+00.00	LT		662+00.00	LT	23,525	0.65
662+00.00	LT		667+50.00	LT	21,641	0.60
TOTAL						2.72
ROUNDED TOTAL						2.75

25100630 EROSION CONTROL BLANKET						
STATION	OFF	TO	STATION	OFF	AREA	QUANTITY
	LT/RT			LT/RT	SF	SY
621+00.00	RT		627+00.00	RT	4,164	463
627+00.00	RT		630+00.00	RT	399	45
649+00.00	RT		650+00.00	RT	536	60
650+00.00	RT		656+00.00	RT	4,019	447
650+00.00	LT		656+00.00	LT	10,538	1,171
656+00.00	LT		662+00.00	LT	28,694	3,189
662+00.00	LT		667+50.00	LT	20,338	2,260
TOTAL						7,635

25100900 TURF REINFORCEMENT MAT						
STATION	OFF	LENGTH	WIDTH	AREA	QUANTITY	
	LT/RT	FT	FT	SF	SY	
624+94.20	RT	50	4	200	23	
625+19.14	LT	50	4	200	23	
626+16.22	RT	50	4	200	23	
626+42.13	LT	50	4	200	23	
666+21.71	LT	125	42	5,250	584	
656+00.00	LT			0	0	
662+00.00	LT			0	0	
TOTAL						676

28000250 TEMPORARY EROSION CONTROL SEEDING			
AREA	APPLICATION	RATE	QUANTITY
ACRE		100LB/AC	LB
6	1	100	600
6	2	100	600
6	3	100	600
6	4	100	600
6	5	100	600
6	6	100	600
TOTAL			3,600

28000305 TEMPORARY DITCH CHECKS			
STATION	OFF	LENGTH	
	LT/RT	FOOT	
623+50.00	RT	10	
626+89.65	LT	10	
627+00.00	RT	10	
628+00.00	RT	10	
649+81.00	RT	10	
650+14.00	RT	10	
650+47.00	RT	10	
650+80.00	RT	10	
652+00.00	RT	10	
653+00.00	RT	10	
TOTAL			100

25000400 NITROGEN FERTILIZER NUTRIENT									
STATION	OFF	TO	STATION	OFF	SEEDING	AREA	AREA	APPLICATION	QUANTITY
	LT/RT			LT/RT		SF	ACRE	RATE	POUND
621+00.00	RT		627+00.00	RT	2A	10,510	0.29	90	27
621+00.00	LT		627+00.00	LT	2A	7,554	0.21	90	19
627+00.00	RT		630+00.00	RT	2A	5,668	0.16	90	15
627+00.00	LT		630+00.00	RT	2A	4,672	0.13	90	12
649+00.00	RT		650+00.00	RT	2A	829	0.02	90	3
650+00.00	RT		656+00.00	RT	2A	7,186	0.20	90	18
650+00.00	LT		656+00.00	LT	2A	17,314	0.48	90	43
656+00.00	LT		662+00.00	LT	2A	23,525	0.65	90	59
662+00.00	LT		667+50.00	LT	2A	21,641	0.60	90	54
621+00.00	RT		627+00.00	RT	4	4,164	0.14	90	13
627+00.00	RT		630+00.00	RT	4	399	0.01	90	2
649+00.00	RT		650+00.00	RT	4	536	0.02	90	2
650+00.00	RT		656+00.00	RT	4	4,019	0.14	90	13
650+00.00	LT		656+00.00	LT	4	10,538	0.36	90	33
656+00.00	LT		662+00.00	LT	4	28,694	0.99	90	89
662+00.00	LT		667+50.00	LT	4	20,338	0.70	90	64
TOTAL									250

25000500 PHOSPHORUS FERTILIZER NUTRIENT									
STATION	OFF	TO	STATION	OFF	SEEDING	AREA	AREA	APPLICATION	QUANTITY
	LT/RT			LT/RT		SF	ACRE	RATE	POUND
621+00.00	RT		627+00.00	RT	2A	10,510	0.29	90	27
621+00.00	LT		627+00.00	LT	2A	7,554	0.21	90	19
627+00.00	RT		630+00.00	RT	2A	5,668	0.16	90	15
627+00.00	LT		630+00.00	RT	2A	4,672	0.13	90	12
649+00.00	RT		650+00.00	RT	2A	829	0.02	90	3
650+00.00	RT		656+00.00	RT	2A	7,186	0.20	90	18
650+00.00	LT		656+00.00	LT	2A	17,314	0.48	90	43
656+00.00	LT		662+00.00	LT	2A	23,525	0.65	90	59
662+00.00	LT		667+50.00	LT	2A	21,641	0.60	90	54
621+00.00	RT		627+00.00	RT	4	4,164	0.14	90	13
627+00.00	RT		630+00.00	RT	4	399	0.01	90	2
649+00.00	RT		650+00.00	RT	4	536	0.02	90	2
650+00.00	RT		656+00.00	RT	4	4,019	0.14	90	13
650+00.00	LT		656+00.00	LT	4	10,538	0.36	90	33
656+00.00	LT		662+00.00	LT	4	28,694	0.99	90	89
662+00.00	LT		667+50.00	LT	4	20,338	0.70	90	64
TOTAL									250

25000600 POTASSIUM FERTILIZER NUTRIENT									
STATION	OFF	TO	STATION	OFF	SEEDING	AREA	AREA	APPLICATION	QUANTITY
	LT/RT			LT/RT		SF	ACRE	RATE	POUND
621+00.00	RT		627+00.00	RT	2A	10,510	0.29	90	27
621+00.00	LT		627+00.00	LT	2A	7,554	0.21	90	19
627+00.00	RT		630+00.00	RT	2A	5,668	0.16	90	15
627+00.00	LT		630+00.00	RT	2A	4,672	0.13	90	12
649+00.00	RT		650+00.00	RT	2A	829	0.02	90	3
650+00.00	RT		656+00.00	RT	2A	7,186	0.20	90	18
650+00.00	LT		656+00.00	LT	2A	17,314	0.48	90	43
656+00.00	LT		662+00.00	LT	2A	23,525	0.65	90	59
662+00.00	LT		667+50.00	LT	2A	21,641	0.60	90	54
621+00.00	RT		627+00.00	RT	4	4,164	0.14	90	13
627+00.00	RT		630+00.00	RT	4	399	0.01	90	2
649+00.00	RT		650+00.00	RT	4	536	0.02	90	2
650+00.00	RT		656+00.00	RT	4	4,019	0.14	90	13
650+00.00	LT		656+00.00	LT	4	10,538	0.36	90	33
656+00.00	LT		662+00.00	LT	4	28,694	0.99	90	89
662+00.00	LT		667+50.00	LT	4	20,338	0.70	90	64
TOTAL									250

FILE NAME = s:\jpl\6386-6399\6346\027\mcr\oa\sh\sh\sh-sched\sh.dgn



USER NAME = b-ianf	DESIGNED -	REVISED -
PLOT SCALE = 28,8882 ' / IN.	DRAWN -	REVISED -
PLOT DATE = 7/19/2011	CHECKED -	REVISED -
	DATE -	REVISED -

STATE OF ILLINOIS
DEPARTMENT OF TRANSPORTATION

SCHEDULE OF QUANTITIES

SCALE: AS SHOWN SHEET NO. OF SHEETS STA. TO STA.

F.A.P. RTE. 585	SECTION 128 BR	COUNTY HENRY	TOTAL SHEETS 106	SHEET NO. 14

28000400 PERIMETER EROSION BARRIER					
STATION	OFF	TO	STATION	OFF	QUANTITY
	LT/RT			LT/RT	FT
621+00.00	LT		621+00.00	LT	5.0
621+00.00	LT		622+50.00	LT	150.0
621+25.00	RT		621+25.00	RT	20.0
621+25.00	RT		622+50.00	RT	125.0
622+50.00	RT		623+00.00	RT	55.0
622+50.00	LT		623+50.00	LT	105.0
623+00.00	RT		623+50.00	RT	55.0
623+20.00	LT		624+50.00	LT	100.0
624+50.00	LT		625+45.00	LT	100.0
626+35.00	LT		627+00.00	LT	66.0
627+00.00	LT		628+00.00	LT	100.0
628+00.00	LT		628+25.00	LT	26.0
628+25.00	LT		628+50.00	LT	25.0
628+50.00	LT		629+00.00	LT	55.0
628+50.00	RT		629+73.00	RT	125.0
629+00.00	LT		630+00.00	LT	100.0
629+73.00	RT		629+73.00	RT	20.0
630+00.00	LT		630+00.00	LT	5.0
649+00.00	RT		649+00.00	RT	10.0
649+00.00	RT		649+50.00	RT	50.0
649+50.00	RT		649+85.00	RT	40.0
TOTAL					1,337

28000500 INLET AND PIPE PROTECTION			
STATION	OFF	OFF	QUANTITY
	FT	LT/RT	EACH
624+25.13	54.6	RT	1
626+26.27	52.8	RT	1
TOTAL			2

28200200 FILTER FABRIC					
STATION	OFF	TO	STATION	OFF	AREA
	LT/RT			LT/RT	SY
650+55.56	RT		651+42.31	RT	206
651+92.64	LT		652+65.98	LT	283
TOTAL					489

28500400 ARTICULATED BLOCK REVETMENT MAT						
STATION	OFF	TO	STATION	OFF	AREA	QUANTITY
	LT/RT			LT/RT	SF	SY
650+55.56	RT		651+42.31	RT	1,850	206
651+92.64	LT		652+65.98	LT	2,550	283
TOTAL						489

31100910 SUBBASE GRANULAR MATERIAL, TYPE A 12"							
SHT	STATION	TO	STATION	WIDTH	OFF	LENGTH	QUANTITY
				FT	LT/RT	FT	SQ YD
PP1	621+00.00		622+50.00	9	LT	150.0	150
PP2	622+50.00		623+91.99	9	LT	142.0	142
PP2	623+91.99		624+76.00	13	LT	84.0	122
PP2	624+76.00		625+00.32	12	LT	24.3	33
PP2	626+63.76		627+85.28	12	LT	121.5	163
PP2	627+85.28		628+00.00	13	LT	14.7	22
PP3	628+00.00		630+00.00	9	LT	200.0	200
TOTAL							832

40200800 AGGREGATE SURFACE COURSE, TYPE B			
STATION	OFF	PURPOSE	QUANTITY
	LT/RT		TON
635+45.00	RT	FIELD ENTRANCE	45
			45

40600625 LEVELING BINDER (MACHINE METHOD), N50								
SHT	STATION	TO	STATION	WIDTH	OFF	THICKNESS	LENGTH	QUANTITY
				FT	LT/RT	INCH	FT	TON
PP2	623+45.00		624+85.96	26	LT/RT	2	140.96	46.0
PP2	626+49.39		627+55.00	26	LT/RT	2	105.61	35.0
TOTAL								81.0

40600982 HOT-MIX ASPHALT SURFACE REMOVAL - BUTT JOINT							
SHT	STATION	TO	STATION	WIDTH	OFF	LENGTH	QUANTITY
				FT	LT/RT	FT	SQ YD
PP2	623+00.00		623+45.00	26	LT/RT	45.00	130.0
PP2	627+55.00		628+00.00	26	LT/RT	45.00	130.0
TOTAL							260.0

40603310 HMA SURFACE COURSE, MIX C", N50								
SHT	STATION	TO	STATION	WIDTH	OFF	THICKNESS	LENGTH	QUANTITY
				FT	LT/RT	INCH	FT	TON
PP1	621+00.00		622+50.00	7	LT	1.5	150.00	10
PP1	621+27.00		622+67.13	7	RT	1.5	140.13	10
PP2	622+50.00		623+00.00	7	LT	1.5	50.00	4
PP2	623+00.00		624+85.95	20	LT	1.5	185.95	35
PP2	626+49.39		628+00.00	20	LT	1.5	150.61	29
PP2	628+00.00		628+50.00	7	LT	1.5	50.00	4
PP2	622+67.13		623+00.00	7	RT	1.5	32.87	3
PP2	623+00.00		624+85.95	20	RT	1.5	185.95	35
PP2	626+49.39		628+00.00	20	RT	1.5	150.61	29
PP3	628+00.00		630+00.00	7	LT	1.5	200.00	14
PP3	628+69.28		629+71.00	7	RT	1.5	101.72	7
PP6	654+50.00		660+00.00	3	LT	1.5	550.00	16
PP7	660+00.00		666+00.00	3	LT	1.5	600.00	17
PP8	666+00.00		667+00.00	3	LT	1.5	100.00	3
TOTAL								216

42001430 BRIDGE APPROACH PAVEMENT CONNECTOR (FLEXIBLE)							
SHT	STATION	TO	STATION	WIDTH (SKEW)	OFF	LENGTH	QUANTITY
				FT	LT/RT	FT	SQ YD
PP2	624+85.96		624+91.96	48	LT/RT	6.00	32
PP2	626+43.39		626+49.39	48	LT/RT	6.00	32
TOTAL							64

44000100 PAVEMENT REMOVAL							
SHT	STATION	TO	STATION	WIDTH	OFF	LENGTH	QUANTITY
				FT	LT/RT	FT	SQ YD
PP2	624+85.96		625+38.84	26	LT/RT	52.88	153
PP2	625+97.16		626+49.39	26	LT/RT	52.23	151
TOTAL							304

44300200 STRIP REFLECTIVE CRACK CONTROL TREATMENT			
STATION	TO	STATION	QUANTITY
			FT
623+00.00		624+85.96	186
626+49.39		628+00.00	151
TOTAL			337

50105220 PIPE CULVERT REMOVAL					
STATION	OFF	TO	STATION	OFF	LENGTH
	LT/RT			LT/RT	FT
624+42.75	RT		625+22.29	RT	80
625+66.05	RT		629+25.51	RT	360
TOTAL					440

48203023 HOT-MIX ASPHALT SHOULDERS, 6 1/2"							
SHT	STATION	TO	STATION	WIDTH	OFF	LENGTH	QUANTITY
				FT	LT/RT	FT	SQ YD
PP1	621+00.00		622+50.00	7	LT	150.00	117
PP1	621+27.00		622+67.13	7	RT	140.13	109
PP2	622+50.00		623+91.99	7	LT	141.99	111
PP2	623+91.99		624+76.00	11	LT	84.01	103
PP2	624+76.00		625+00.32	10	LT	24.32	28
PP2	626+63.76		627+85.28	10	LT	121.52	136
PP2	627+85.28		628+00.00	11	LT	14.72	18
PP2	622+67.13		623+51.05	11	RT	83.92	103
PP2	623+51.05		624+71.58	10	RT	120.53	134
PP2	626+35.02		626+71.87	10	RT	36.85	41
PP2	626+71.87		627+44.67	17	RT	72.80	138
PP2	627+44.67		628+00.00	7	RT	55.33	44
PP3	628+00.00		630+00.00	7	LT	200.00	156
PP3	628+69.28		629+71.00	7	RT	101.72	80
PP6	654+50.00		660+00.00	3	LT	550.00	184
PP7	660+00.00		666+00.00	3	LT	600.00	200
PP8	666+00.00		667+00.00	3	LT	100.00	34
TOTAL							1,736

54215559 METAL END SECTIONS 24"							
STATION	OFF	OFF	TO	STATION	OFF	OFF	QUANTITY
	FT	LT/RT			FT		EACH
624+25.00	54.7	RT		624+28.36	54.0	RT	1
626+21.73	51.8	RT		626+25.00	52.9	RT	1
TOTAL							2

542D1069 PIPE CULVERTS, CLASS D, TYPE 2 24"										
STATION	OFF	OFF	TO	STATION	OFF	OFF	US INVERT	DS INVERT	SLOPE	LENGTH
	FT	LT/RT			FT	LT/RT	FT	FT	%	FT
624+28.36	54.0	RT		625+25.00	36.3	RT	603.07	600.24	2.87	99
625+65.00	34.4	RT		626+21.73	51.8	RT	604.05	600.24	6.44	60
TOTAL										159

60801024 FLAP GATE 24"		
STATION	OFF	QUANTITY
	LT/RT	EACH
625+25.00	RT	1
625+65.00	RT	1
TOTAL		2

63000001 STEEL PLATE BEAM GUARD RAIL, TYPE A, 6 FOOT POSTS					
STATION	OFF	TO	STATION	OFF	
	LT/RT			LT/RT	
623+51.03	RT		624+51.03	RT	100.0
626+85.28	LT		627+85.28	LT	100.0
TOTAL					200.0

63100085 TRAFFIC BARRIER TERMINAL, TYPE 6					
STATION	OFF	TO	STATION	OFF	QUANTITY
	LT/RT			LT/RT	EACH
624+51.03	RT		624+94.18	RT	1
624+75.97	LT		625+19.12	LT	1
626+17.61	RT		626+60.76	RT	1
626+42.13	LT		626+85.28	LT	1
TOTAL					4

63100167 TRAFFIC BARRIER TERMINAL, TYPE 1 (SPECIAL) TANGENT					
STATION	OFF	TO	STATION	OFF	QUANTITY
	LT/RT			LT/RT	EACH
623+01.03	RT		623+51.03	RT	1
624+25.97	LT		624+75.97	LT	1
627+85.28	LT		628+35.28	LT	1
TOTAL					3

FILE NAME = S:\JUL_63009--63991_6346_027\Micro\Sh\sh\sh-schedul.p2.dgn

 1170 SOUTH HOUBOLT ROAD JOLIET, ILLINOIS 60431 (815) 744-4200	USER NAME = raymondk	DESIGNED -	REVISED -	STATE OF ILLINOIS DEPARTMENT OF TRANSPORTATION	SCHEDULE OF QUANTITIES				F.A.P. RTE. 585	SECTION 128 BR	COUNTY HENRY	TOTAL SHEETS 106	SHEET NO. 15
	PLOT SCALE = 20,0000' / IN.	DRAWN -	REVISED -		SCALE: AS SHOWN	SHEET NO.	OF	SHEETS	STA.	TO STA.	CONTRACT NO. 64C20		
	PLOT DATE = 7/21/2011	CHECKED -	REVISED -		FED. ROAD DIST. NO. 2	ILLINOIS FED. AID PROJECT							
		DATE -	REVISED -										

63100169 TRAFFIC BARRIER TERMINAL, TYPE 1 (SPECIAL) FLARED					
STATION	OFF	TO	STATION	OFF	QUANTITY
	LT/RT				EACH
626+60.76	RT		627+10.76	RT	1
TOTAL					1

63200310 GUARDRAIL REMOVAL					
STATION	OFF	TO	STATION	OFF	LENGTH
	LT/RT				FT
624+23.11	RT		625+24.32	RT	102
624+50.07	LT		625+51.94	LT	102
625+84.59	RT		625+99.27	RT	15
626+11.47	LT		627+12.97	LT	102
626+22.66	RT		626+86.25	LT	65
649+00.00	RT		653+09.87	RT	410
651+43.96	LT		654+37.62	LT	294
TOTAL					386

63500105 DELINEATORS		
STATION	OFF	QUANTITY
	LT/RT	EACH
623+01.03	RT	1
624+25.97	LT	1
627+10.76	RT	1
628+35.28	LT	1
651+35.26	RT	1
651+93.36	LT	1
TOTAL		6

66500105 WOVEN WIRE FENCE, 4'					
STATION	OFF	TO	STATION	OFF	LENGTH
	LT/RT				FT
624+09.81	LT		625+11.40	LT	102
TOTAL					102

66600105 FURNISHING AND ERECTING RIGHT-OF-WAY MARKERS			
STATION	OFF	OFF	QUANTITY
	FT	LT/RT	EACH
622+25.00	40	RT	1
622+50.00	55	RT	1
623+25.00	55	RT	1
623+50.00	46	LT	1
623+75.00	60	LT	1
624+00.00	75	RT	1
627+00.00	75	RT	1
628+00.00	60	LT	1
628+25.00	46	LT	1
628+50.00	42	RT	1
649+50.00	42	RT	1
650+75.00	90	RT	1
651+19.68	53	LT	1
651+50.00	105	LT	1
652+00.00	90	RT	1
653+00.00	42	RT	1
655+00.00	105	LT	1
655+50.00	125	LT	1
666+50.00	125	LT	1
667+40.83	50	LT	1
TOTAL			20

70300280 TEMPORARY PAVEMENT MARKING - LINE 24"		
STATION	OFF	LENGTH
	LT/RT	FT
619+81.00	RT	12
631+26.48	LT	12
TOTAL		24

70300220 TEMPORARY PAVEMENT MARKING - LINE 4"								
	STATION	OFF	OFF	TO	STATION	OFF	OFF	LENGTH
		FT	LT/RT			FT	LT/RT	FT
STAGE1	620+41.00	12.0	LT		622+25.00	7.0	RT	186
	622+25.00	7.0	RT		628+82.49	7.0	RT	658
	628+82.49	7.0	RT		631+10.48	12.0	LT/RT	229
	621+42.56	12.0	RT		622+25.00	19.0	RT	83
	622+25.00	19.0	RT		628+82.49	19.0	RT	658
	628+82.49	19.0	RT		628+66.48	12.0	RT	86
STAGE2	619+97.00	12.0	RT		622+25.00	7.0	LT	230
	622+25.00	7.0	LT		628+82.48	7.0	LT	658
	628+82.48	7.0	LT		630+66.48	12.0	RT	186
	621+41.00	12.0	LT		622+25.00	19.0	LT	85
	622+25.00	19.0	LT		628+82.48	19.0	LT	658
	628+82.48	19.0	LT		629+66.48	12.0	LT	86
TOTAL								3,803

70301000 WORK ZONE PAVEMENT MARKING REMOVAL										
	STATION	OFF	OFF	TO	STATION	OFF	OFF	LENGTH	SIZE	QUANTITY
		FT	LT/RT			FT	LT/RT	FT	INCH	SO FT
	619+88.81		RT		STOP BAR			13	24	26
STAGE1	620+52.87	12.0	LT		622+25.00	7.0	RT	174	4	58
	622+25.00	7.0	RT		628+74.41	7.0	RT	650	4	217
	628+74.41	7.0	RT		630+90.33	12.0	LT/RT	217	4	73
	621+42.56	12.0	RT		622+25.00	19.0	RT	83	4	28
	622+25.00	19.0	RT		628+75.01	19.0	RT	650	4	217
	628+75.01	19.0	RT		629+60.69	12.0	RT	86	4	29
STAGE2	620+00.48	12.0	RT		622+25.48	7.0	LT	226	4	76
	622+25.48	7.0	LT		628+74.42	7.0	LT	650	4	217
	628+74.42	7.0	LT		630+46.54	12.0	RT	174	4	58
	621+36.91	12.0	LT		622+24.98	19.0	LT	89	4	30
	622+24.98	19.0	LT		628+75.00	19.0	LT	650	4	217
	628+75.00	19.0	LT		629+60.36	12.0	LT	86	4	29
	631+06.42		LT		STOP BAR			13	24	26
SHORT TERM								174	4	58
TOTAL										1,359

70400100 TEMPORARY CONCRETE BARRIER								
	STATION	OFF	OFF	TO	STATION	OFF	OFF	LENGTH
		FT	LT/RT			FT	LT/RT	FT
STAGE 1	621+48.33	4.6	LT		622+75.00	6	RT	125
	622+75.00	6	RT		628+32.40	6	RT	550
	628+32.40	6	RT		629+59.18	4.6	LT	125
TOTAL								800

70400200 RELOCATE TEMPORARY CONCRETE BARRIER								
	STATION	OFF	OFF	TO	STATION	OFF	OFF	LENGTH
		FT	LT/RT			FT	LT/RT	FT
STAGE 2	621+48.33	4.6	RT		622+75.00	6	LT	125
	622+75.00	6	LT		628+32.40	6	LT	550
	628+32.40	6	LT		629+59.18	4.6	RT	125
TOTAL								800

78001110 PAINT PAVEMENT MARKING - LINE 4"										
STATION	OFF	OFF	TO	STATION	OFF	OFF	TYPE	COLOR	TOTAL	QUANTITY
	FT	LT/RT			FT	LT/RT			FT	FT
619+88.81	0			631+20.65	0		SKIP DASH	YELLOW	283	566
621+36.82	12	LT		629+66.48	12	LT	SOLID	WHITE	830	1,660
621+42.48	12	RT		629+66.48	12	RT	SOLID	WHITE	824	1,648
TOTAL (TWO APPLICATIONS)										3,874

70300100 SHORT TERM PAVEMENT MARKING										
STATION	OFF	OFF	TO	STATION	OFF	OFF	TYPE	COLOR	QUANTITY	
	FT	LT/RT			FT	LT/RT			FT	
619+88.81	0			630+80.65	0		SKIP DASH	YELLOW	110	
621+36.82	12	LT		629+60.44	12	LT	SOLID	WHITE	32	
621+42.48	12	RT		629+60.79	12	RT	SOLID	WHITE	32	
TOTAL									174	

78200410 GUARDRAIL MARKERS, TYPE A						
STATION	OFF	TO	STATION	OFF	LENGTH	QUANTITY
	LT/RT				FT	EACH
623+01.03	RT		624+94.20	RT	194.0	4
624+25.97	LT		625+19.14	LT	94.0	4
626+16.22	RT		627+10.76	RT	95.0	4
626+42.13	LT		628+35.28	LT	194.0	4
TOTAL						16

78200520 BARRIER WALL MARKERS, TYPE B						
STATION	OFF	TO	STATION	OFF	LENGTH	QUANTITY
	LT/RT				FT	EACH
624+94.20	RT		626+16.22	RT	123.0	4
625+19.14	LT		626+42.13	LT	123.0	4
TOTAL						8

78300100 PAVEMENT MARKING REMOVAL									
STATION	OFF	OFF	TO	STATION	OFF	OFF	LENGTH	WIDTH	QUANTITY
	FT	LT/RT			FT	LT/RT	FT	INCH	SO FT
619+88.81	0			630+80.65	0		272.96	4	91
621+36.82	12	LT		629+60.44	12	LT	824	4	275
621+42.48	12	RT		629+60.79	12	RT	818	4	273
TOTAL									639

X4400110 TEMPORARY PAVEMENT REMOVAL							
SHT	STATION	TO	STATION	WIDTH	OFF	LENGTH	QUANTITY
				FT	LT/RT	FT	SO YD
PRESTAGE1	621+27.00		622+00.00	7	RT	73.00	57
PRESTAGE2	622+00.00		628+00.00	7	RT	600.00	467
PRESTAGE3	628+00.00		629+71.00	7	RT	171.00	133
TOTAL							657

X4401198 HOT-MIX ASPHALT SURFACE REMOVAL, VARIABLE DEPTH						
STATION	TO	STATION	WIDTH	OFF	LENGTH	QUANTITY
			FT	LT/RT	FT	SO YD
623+45.00		624+01.00	26	LT/RT	56.00	162
626+49.00		627+55.00	26	LT/RT	106.00	307
TOTAL						469

Z0062456 TEMPORARY PAVEMENT							
SHT	STATION	TO	STATION	WIDTH	OFF	LENGTH	QUANTITY
				FT	LT/RT	FT	SO YD
PRESTAGE1	621+27.00		622+00.00	7	RT	73.00	57
PRESTAGE2	622+00.00		628+00.00	7	RT	600.00	467
PRESTAGE3	628+00.00		629+71.00	7	RT	171.00	133
TOTAL							657

Z0030350 IMPACT ATTENUATORS, RELOCATE (NON-REDIRECTIVE), TEST LEVEL 3			
	QUANTITY		
	EACH		
STAGE 2	2		
TOTAL	2		

78300200 RAISED REFLECTIVE PAVEMENT MARKER REMOVAL				
STATION	TO	STATION	LENGTH	QUANTITY
			FT	EACH
619+88.81		630+80.65	1092.0	14
TOTAL				14

78201000 TERMINAL MARKER - DIRECT APPLIED		
STATION	OFF	QUANTITY
	LT/RT	EACH
623+01.03	RT	1
624+25.97	LT	1
627+10.76	RT	1
628+35.28	LT	1
TOTAL		4

Z0020900 ESTABLISHING AND REFERENCING LAND SECTION MARKERS			
STATION	OFF	OFF	QUANTITY
	LT/RT	FT	EACH
628+04.06	LT	26.2	1
654+30.90	RT	5	1
TOTAL			2

Z0030250 IMPACT ATTENUATORS, TEMPORARY (NON-REDIRECTIVE), TEST LEVEL 3			
	QUANTITY		
	EACH		
STAGE 1	2		
TOTAL	2		

78100100 RAISED REFLECTIVE PAVEMENT MARKER				
STATION	TO	STATION	LENGTH	QUANTITY
			FT	EACH
619+88.81</				

HORIZONTAL CONTROL POINTS							
POINT	NORTH	EAST	ELEVATION	CHAIN	STATION	OFFSET	DESCRIPTION
1	1780077.9200	2334852.8410	608.8090	IL92	OUT OF CHAIN	-----	GPS CONTROL POINT
2	1785594.1760	2374793.7830	623.0000	IL92	OUT OF CHAIN	-----	GPS CONTROL POINT

SURVEY WORK POINTS							
POINT	NORTH	EAST	ELEVATION	CHAIN	STATION	OFFSET	DESCRIPTION
101	1780097.7430	2353325.1820	607.5110	IL92	620+01.70	20.6611' RT	PROFILE
103	1780171.5930	2354577.5950	606.7330	IL92	632+55.49	24.0048' LT	PROFILE
104	1780171.5930	2354577.5950	607.1860	IL92	632+55.49	24.0048' LT	PROFILE
150	1780171.5890	2354577.5130	606.8730	IL92	632+55.41	24.0027' LT	SURVEY WORK POINT
151	1780097.7400	2353325.1820	607.5110	IL92	620+01.70	20.6641' RT	SURVEY WORK POINT
152	1780171.5640	2354577.5330	606.7680	IL92	632+55.43	23.9773' LT	SURVEY WORK POINT
153	1780097.6790	2353325.1440	607.6150	IL92	620+01.66	20.7242' RT	SURVEY WORK POINT
154	1780140.1140	2355456.7790	607.6020	IL92	641+33.70	27.9386' RT	SURVEY WORK POINT
155	1780222.0530	2356710.6110	609.3840	IL92	653+89.10	24.7811' LT	SURVEY WORK POINT
156	1780235.3490	2357633.6370	612.0000	IL92	663+12.19	16.5797' LT	SURVEY WORK POINT
157	1780041.2070	2353877.9340	607.1630	IL92	625+52.98	90.0533' RT	SURVEY WORK POINT
158	1780115.8100	2353902.3440	601.2431	IL92	625+79.12	16.039' RT	SURVEY WORK POINT
159	1780150.6430	2353964.5810	611.3680	IL92	626+42.16	17.3353' LT	SURVEY WORK POINT
160	1780224.4400	2353893.2110	609.4490	IL92	625+72.52	92.7742' LT	SURVEY WORK POINT
161	1780221.3670	2353443.2560	607.2439	IL92	621+22.62	100.1799' LT	SURVEY WORK POINT
162	1780141.2370	2353612.9230	609.1050	IL92	622+90.37	16.1207' LT	SURVEY WORK POINT
170	1780106.4680	2356331.7800	609.3250	IL92	650+07.68	81.951' RT	SURVEY WORK POINT
171	1780055.7630	2356292.7280	608.9120	IL92	649+67.46	131.7329' RT	SURVEY WORK POINT
172	1779946.9040	2356270.8300	609.7780	IL92	649+43.04	240.0524' RT	SURVEY WORK POINT
173	1779890.5140	2356229.3700	610.0990	IL92	649+00.27	295.4617' RT	SURVEY WORK POINT
174	1779819.7220	2356190.7990	610.0150	IL92	648+60.06	365.3363' RT	SURVEY WORK POINT
175	1779756.9370	2356167.2620	609.9710	IL92	648+35.07	427.5562' RT	SURVEY WORK POINT
176	1779706.3040	2356156.4140	609.7160	IL92	648+23.05	477.9228' RT	SURVEY WORK POINT
177	1779604.2450	2356117.6420	610.4050	IL92	647+81.91	579.0513' RT	SURVEY WORK POINT
178	1779507.3840	2356096.6750	610.5200	IL92	647+58.69	675.3978' RT	SURVEY WORK POINT
179	1780174.6520	2356412.7360	609.5104	IL92	650+90.21	15.6706' RT	SURVEY WORK POINT
181	1779461.0300	2356092.5540	610.2290	IL92	647+53.49	721.6433' RT	SURVEY WORK POINT
182	1779404.3620	2356084.6350	609.8460	IL92	647+44.26	778.1115' RT	SURVEY WORK POINT
183	1779354.4890	2356077.5510	609.7050	IL92	647+36.01	827.806' RT	SURVEY WORK POINT
184	1779296.8620	2356071.6120	609.3790	IL92	647+28.73	885.2791' RT	SURVEY WORK POINT

REFERENCE TIES				
POINT	CHAIN	STATION	OFFSET	DESCRIPTION
500	IL92	620+03.04	11.2017' RT	PK NAIL W/ SHINER--EDGE OF PAVEMENT
501	IL92	620+01.32	37.7719' RT	PK NAIL W/ SHINER--POWERPOLE
502	IL92	618+10.67	37.8104' RT	PK NAIL W/ SHINER--POWERPOLE
503	IL92	626+39.87	12.3579' RT	PK NAIL W/ SHINER--EDGE OF PAVEMENT
504	IL92	625+81.73	41.4649' RT	PK NAIL W/ SHINER--POWERPOLE
505	IL92	627+87.03	41.665' RT	PK NAIL W/ SHINER--POWERPOLE
506	IL92	641+24.28	11.0085' RT	PK NAIL W/ SHINER--EDGE OF PAVEMENT
507	IL92	641+46.67	10.7549' RT	PK NAIL W/ SHINER--EDGE OF PAVEMENT
508	IL92	641+74.27	40.9237' RT	PK NAIL W/ SHINER--POWERPOLE
509	IL92	653+89.54	11.8456' LT	PK NAIL W/ SHINER--EDGE OF PAVEMENT
510	IL92	653+70.89	39.9882' RT	PK NAIL W/ SHINER--POWERPOLE
511	IL92	655+63.22	40.333' RT	PK NAIL W/ SHINER--POWERPOLE
512	IL92	663+48.70	41.3523' RT	PK NAIL W/ SHINER--POWERPOLE
513	IL92	663+07.07	11.4075' LT	PK NAIL W/ SHINER--EDGE OF PAVEMENT
514	IL92	665+49.96	41.814' RT	PK NAIL W/ SHINER--POWERPOLE
667	IL92	651+58.57	0.3127' LT	PAVEMENT - CENTERLINE

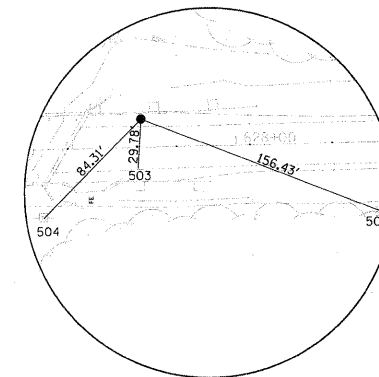

HORIZONTAL CONTROL POINT NO. 159

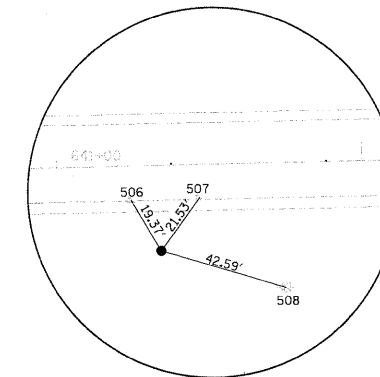

HORIZONTAL CONTROL POINT NO. 154

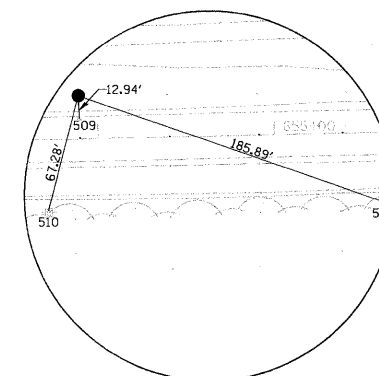

HORIZONTAL CONTROL POINT NO. 155

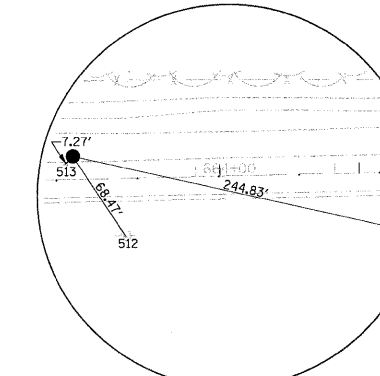

HORIZONTAL CONTROL POINT NO. 156



Chain IL92 contains:
4 3 5

Beginning chain IL92 description

Point 4 N 1,780,060.1432 E 2,350,823.6806 Sta 595+00.00

Course from 4 to 3 88° 39' 56.42" Dist 3,068.0000'

Point 3 N 1,780,131.5856 E 2,353,890.8487 Sta 625+68.00

Course from 3 to 5 88° 39' 56.42" Dist 4,632.0000'

Point 5 N 1,780,239.4476 E 2,358,521.5927 Sta 672+00.00

Ending chain IL92 description

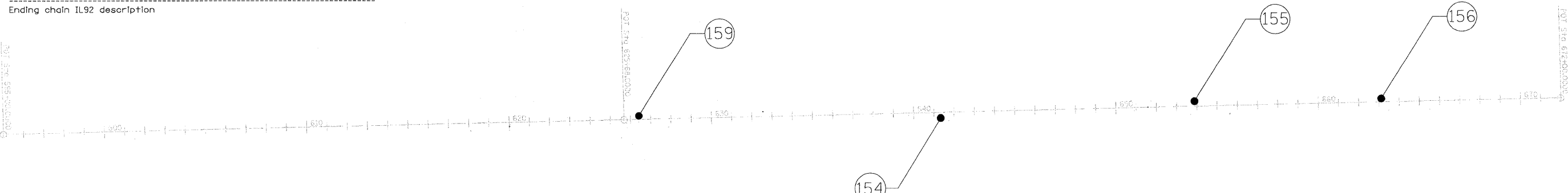

FILE NAME = s:\p\63000-63959\63416\027\mcrora\hst\hst-hva.dgn



1170 SOUTH HOUBOLT ROAD JOLIET, ILLINOIS 60431 (815) 744-4200	USER NAME = brianf	DESIGNED -	REVISED -
PLOT SCALE = 28.0000' / IN.	CHECKED -	REVISED -	REVISED -
PLOT DATE = 7/19/2011	DATE -	REVISED -	REVISED -

STATE OF ILLINOIS
DEPARTMENT OF TRANSPORTATION

HORIZONTAL AND VERTICAL CONTROL

SCALE: AS SHOWN SHEET NO. OF SHEETS STA. TO STA.

F.A.P. RTE. 585	SECTION 128 BR	COUNTY HENRY	TOTAL SHEETS 106	SHEET NO. 17
CONTRACT NO. 64C20				
FED. ROAD DIST. NO. 2 ILLINOIS FED. AID PROJECT				

DATE	
BY	
SURVEYED	
PLOTTED	
ALIGNED	
CHECKED	
FILE NAME	
NO.	
PLAN	
NOTE BOOK	

DATE	
BY	
SURVEYED	
PLOTTED	
GRADES CHECKED	
STRUCTURE NOTATIONS DRTD	
NO.	
FILE NAME	
NO.	

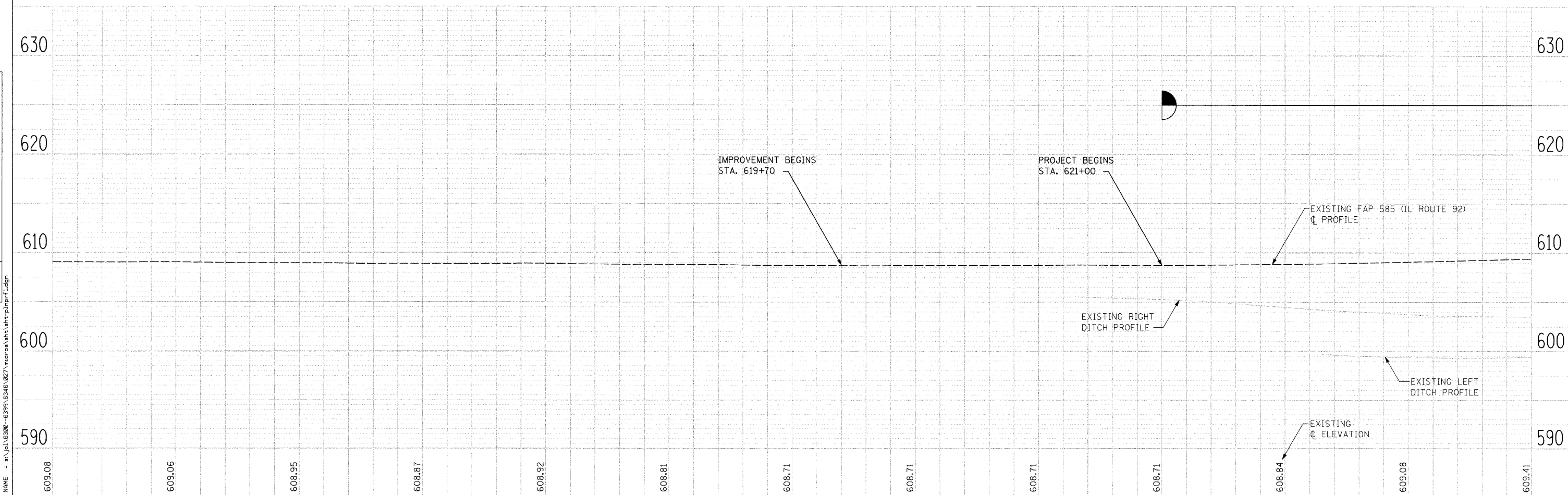
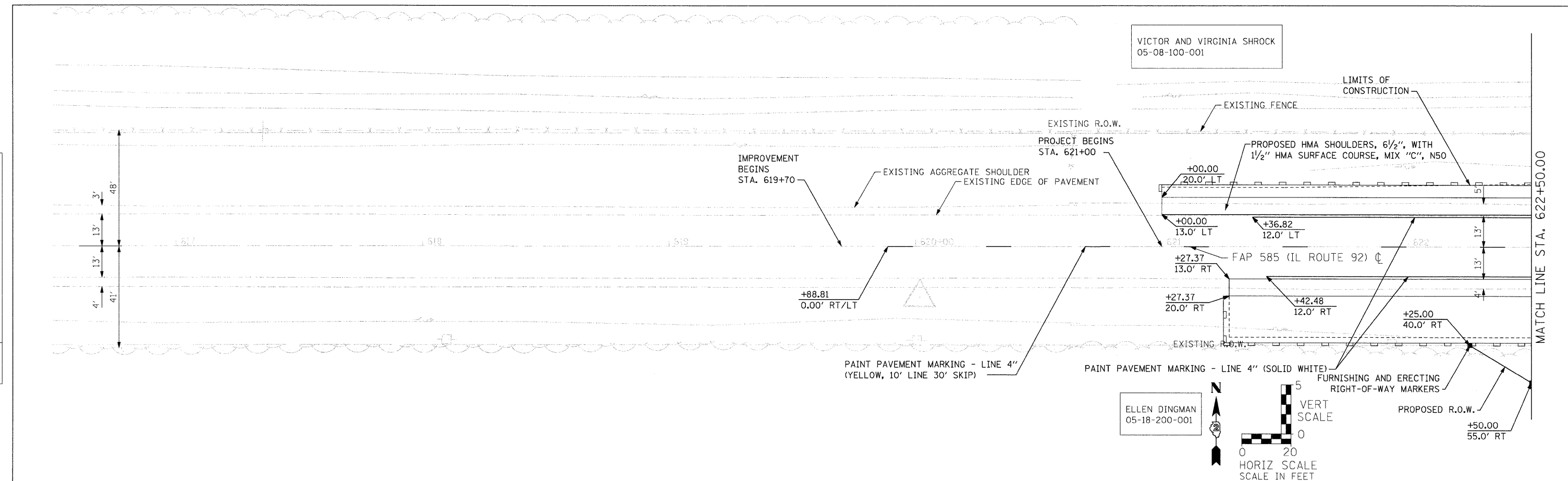

609.08	609.06	608.95	608.87	608.92	608.81	608.71	608.71	608.71	608.71	608.84	609.08	609.41			
616+50	617+00	617+50	618+00	618+50	619+00	619+50	620+00	620+50	621+00	621+50	622+00	622+50			
USER NAME = brianf DESIGNED - VLF CHECKED - RKK PLOT SCALE = 20,0000' / IN. PLOT DATE = 7/19/2011				REVISED - REVISED - REVISED - REVISED -				STATE OF ILLINOIS DEPARTMENT OF TRANSPORTATION				PLAN AND PROFILE - BRIDGE			
1170 SOUTH HOUBOLT ROAD JOLIET, ILLINOIS 60431 (815) 744-4200 STRAND ASSOCIATES, INC. ENGINEERS				COUNTY HENRY TOTAL SHEETS 106 SHEET NO. 18 CONTRACT NO. 64C20				SCALE: AS SHOWN SHEET NO. OF SHEETS STA. 116+50 TO STA. 622+50.00 FED. ROAD DIST. NO. 2 ILLINOIS FED. AID PROJECT							

DATE	
BY	
REVISION	
APPROVED	
ALIGNED	
CHECKED	
NO. FILE NAME	
PLAN	
NOTE BOOK	
NO.	
FILE NAME	

DATE	
BY	
REVISION	
APPROVED	
ALIGNED	
CHECKED	
NO. FILE NAME	
PROFILE	
NOTE BOOK	
NO.	
FILE NAME	

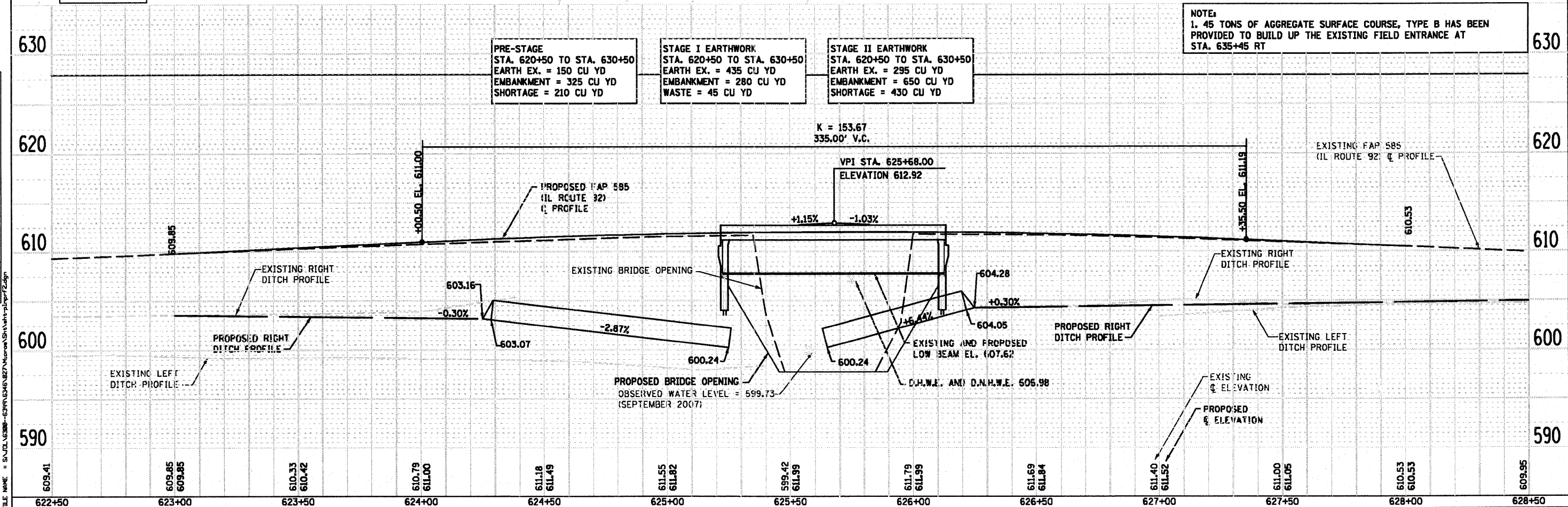
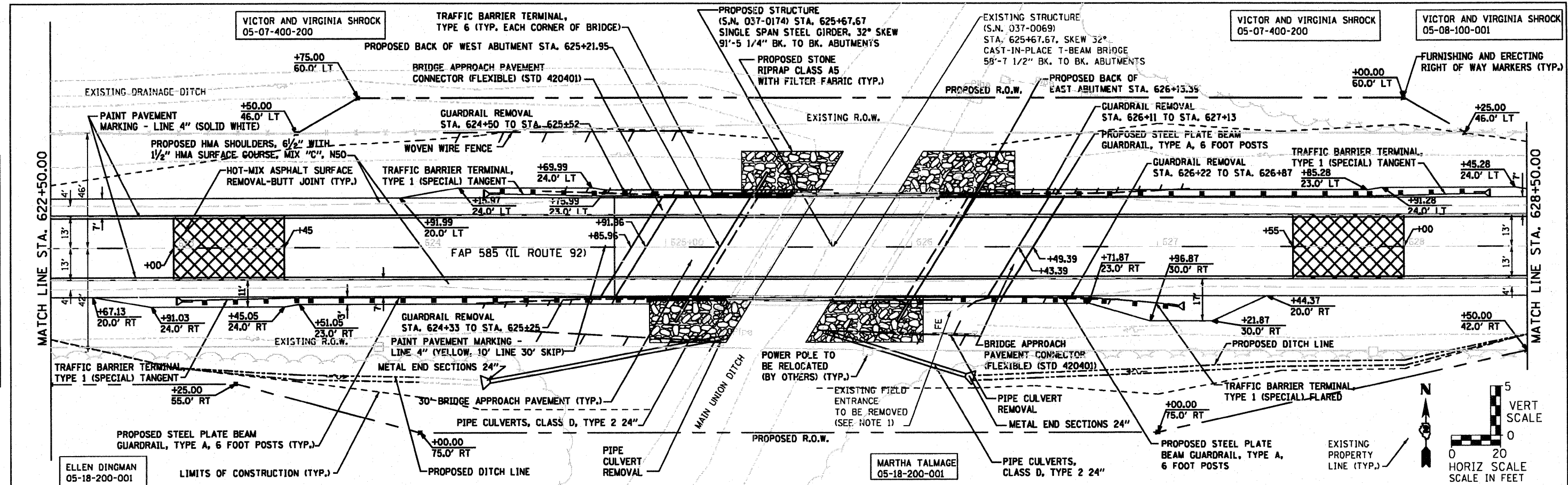

1170 SOUTH HOBOLT ROAD JOLIET, ILLINOIS 60431 (815) 744-4200	USER NAME = ragnondk DESIGNED - VLF CHECKED - RKK DRAWN - B.J.F. CHECKED - RKK	REVISED - REVISED - REVISED - REVISED -	STATE OF ILLINOIS DEPARTMENT OF TRANSPORTATION		PLAN AND PROFILE - BRIDGE		F.A.P. R.T.E. 585 SECTION 128 BR COUNTY HENRY CONTRACT NO. 64C20
	PLOT SCALE = 48.8888" / IN. PLOT DATE = 7/21/2011	SCALE: AS SHOWN SHEET NO. OF SHEETS STA. 622+50.00 TO STA. 628+50.00			FED. ROAD DIST. NO. 2 ILLINOIS FED. AID PROJECT		TOTAL SHEETS 19 SHEET NO. 19

VICTOR AND VIRGINIA SHROCK
05-08-100-001

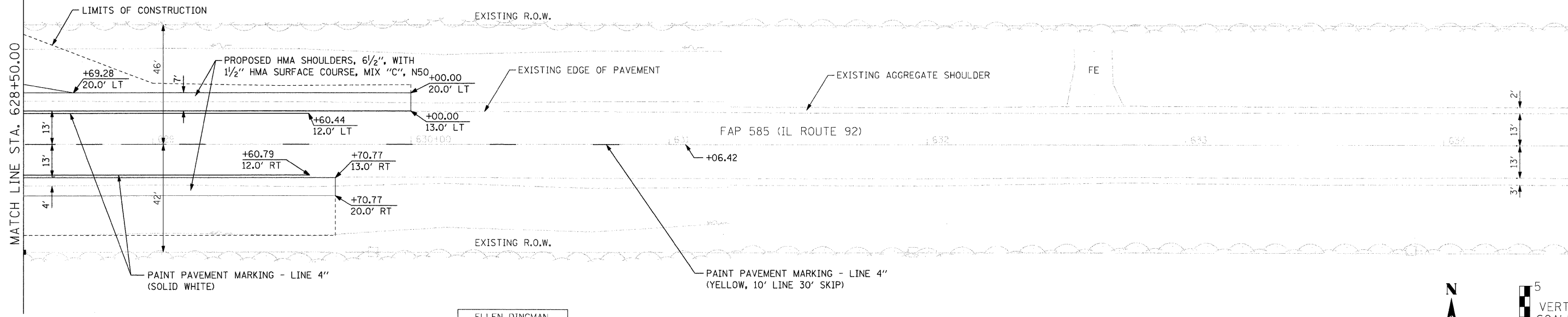

ELLEN DINGMAN
05-17-100-001

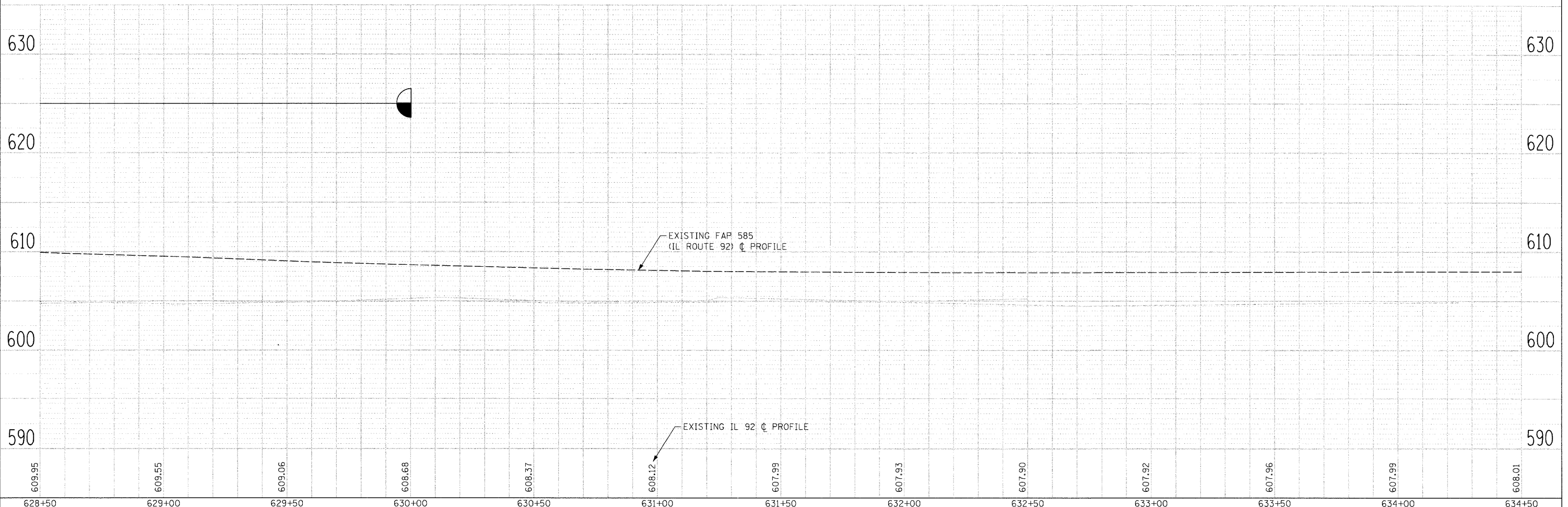
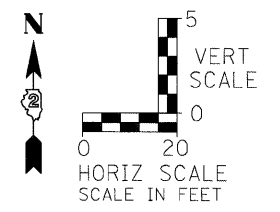

DATE	
BY	
FILE	
NO.	
DATE	
BY	
FILE	
NO.	

DATE	
BY	
FILE	
NO.	
DATE	
BY	
FILE	
NO.	

FILE NAME = s:\j\16300-6399\6346\027\macro.dwg

609.95	609.55	609.06	608.68	608.37	608.12	607.99	607.93	607.90	607.92	607.96	607.99	608.01
628+50	629+00	629+50	630+00	630+50	631+00	631+50	632+00	632+50	633+00	633+50	634+00	634+50

1170 SOUTH HOUBOLT ROAD
JOLIET, ILLINOIS 60431
(815) 744-4200

USER NAME = brianf	DESIGNED - VLF	REVISED -
PLOT SCALE = 20.0000' / IN.	CHECKED - RKK	REVISED -
PLOT DATE = 7/19/2011	DRAWN - BJF	REVISED -
	CHECKED - RKK	REVISED -

STATE OF ILLINOIS
DEPARTMENT OF TRANSPORTATION

PLAN AND PROFILE - BRIDGE			
SCALE: AS SHOWN	SHEET NO.	OF SHEETS	STA. 628+50.00 TO STA. 634+50.00

F.A.P. RTE. 585	SECTION 128 BR	COUNTY HENRY	TOTAL SHEETS 106	SHEET NO. 20
CONTRACT NO. 64C20				
FED. ROAD DIST. NO. 2 ILLINOIS FED. AID PROJECT				

PLAN	SURVEYED	DATE
	PLOTTED	BY
	ALIGNED	
	CHECKED	
	FILED	
	NO. _____	
	FILE NAME	

FILE	REVISIONS	DATE
	GRADES CHECKED	
	STRUCTURE NOTATIONS CHECKED	
	NO. _____	
	FILE NAME	

VICTOR & VIRGINIA SHROCK
05-08-100-001

WILLIAM RUTHERFORD
05-08-200-003

EXISTING FENCE

EXISTING R.O.W.

EXISTING AGGREGATE SHOULDER
EXISTING EDGE OF PAVEMENT

FAP 585 (IL RTE 92)

EXISTING R.O.W.

MELVIN & MARLENE SADD
05-17-100-003

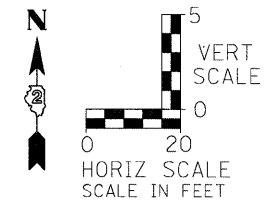

MATCH LINE STA. 648+00.00

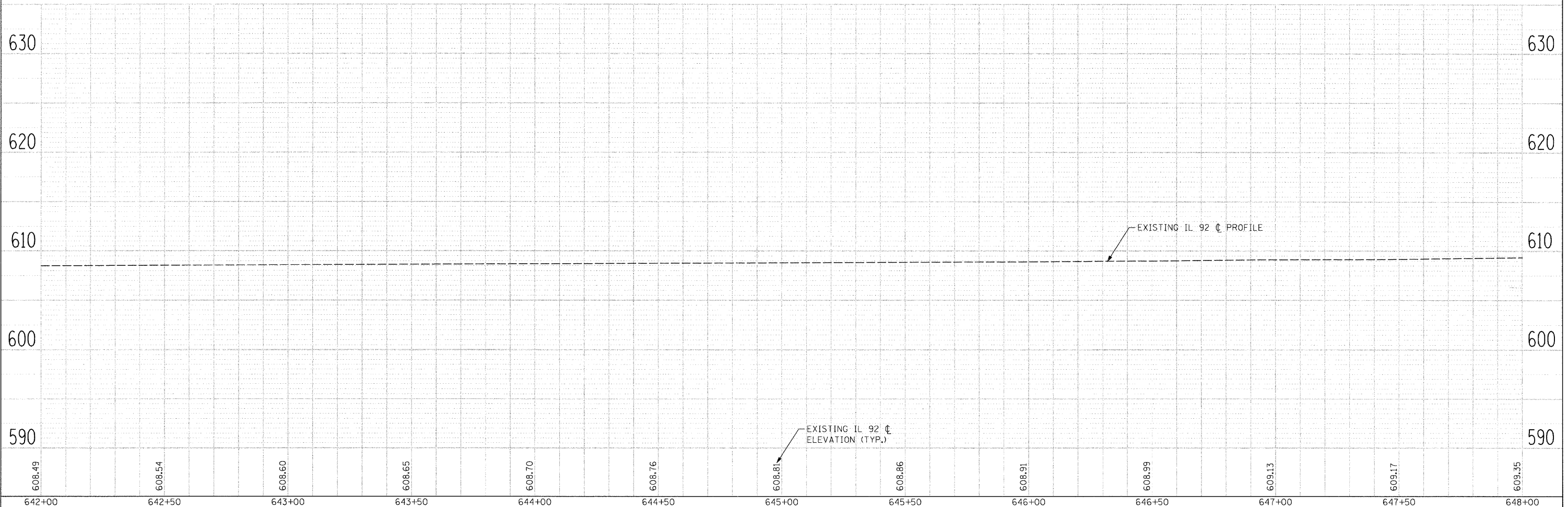

FILE NAME = m:\p162800-6399\6346\027\micro\wh\whtr\p162800\F4.dgn

608.49	608.54	608.60	608.65	608.70	608.76	608.81	608.86	608.91	608.99	609.13	609.17	609.35					
642+00	642+50	643+00	643+50	644+00	644+50	645+00	645+50	646+00	646+50	647+00	647+50	648+00					
USER NAME = brianf DESIGNED - CHECKED - PLOT SCALE = 20.0000' / IN. DRAWN - PLOT DATE = 7/19/2011 CHECKED -						REVISED - REVISED - REVISED - REVISED -						STATE OF ILLINOIS DEPARTMENT OF TRANSPORTATION		PLAN AND PROFILE - CULVERT /DITCH		F.A.P. RTE. 585 SECTION 128 BR COUNTY HENRY TOTAL SHEETS 106 SHEET NO. 21 CONTRACT NO. 64C20	
STRAND ASSOCIATES, INC. ENGINEERS 1170 SOUTH HOUBOLT ROAD JOLIET, ILLINOIS 60431 (815) 744-4200						SCALE: AS SHOWN SHEET NO. OF SHEETS STA. 642+00.00 TO STA. 648+00.00						FED. ROAD DIST. NO. ILLINOIS FED. AID PROJECT					

STA/OFF CALLOUTS SHOWN IN DETAILS 'A' AND 'B' ARE ALONG THE CENTERLINE OF THE CULVERT

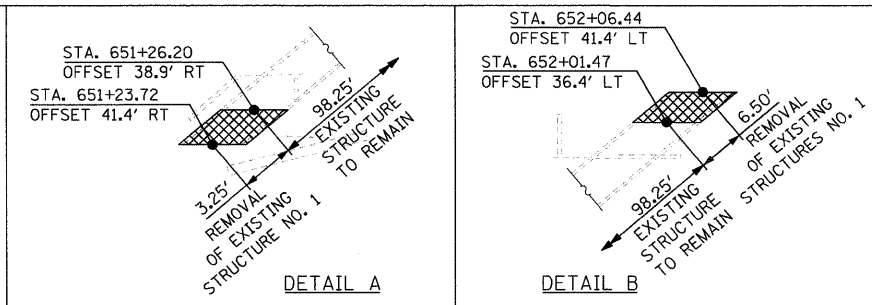

DATE	
BY	
PLAN	
NO. 1	
NO. 2	
NO. 3	
NO. 4	
NO. 5	
NO. 6	
NO. 7	
NO. 8	
NO. 9	
NO. 10	

DATE	
BY	
FILE	
NO. 1	
NO. 2	
NO. 3	
NO. 4	
NO. 5	
NO. 6	
NO. 7	
NO. 8	
NO. 9	
NO. 10	

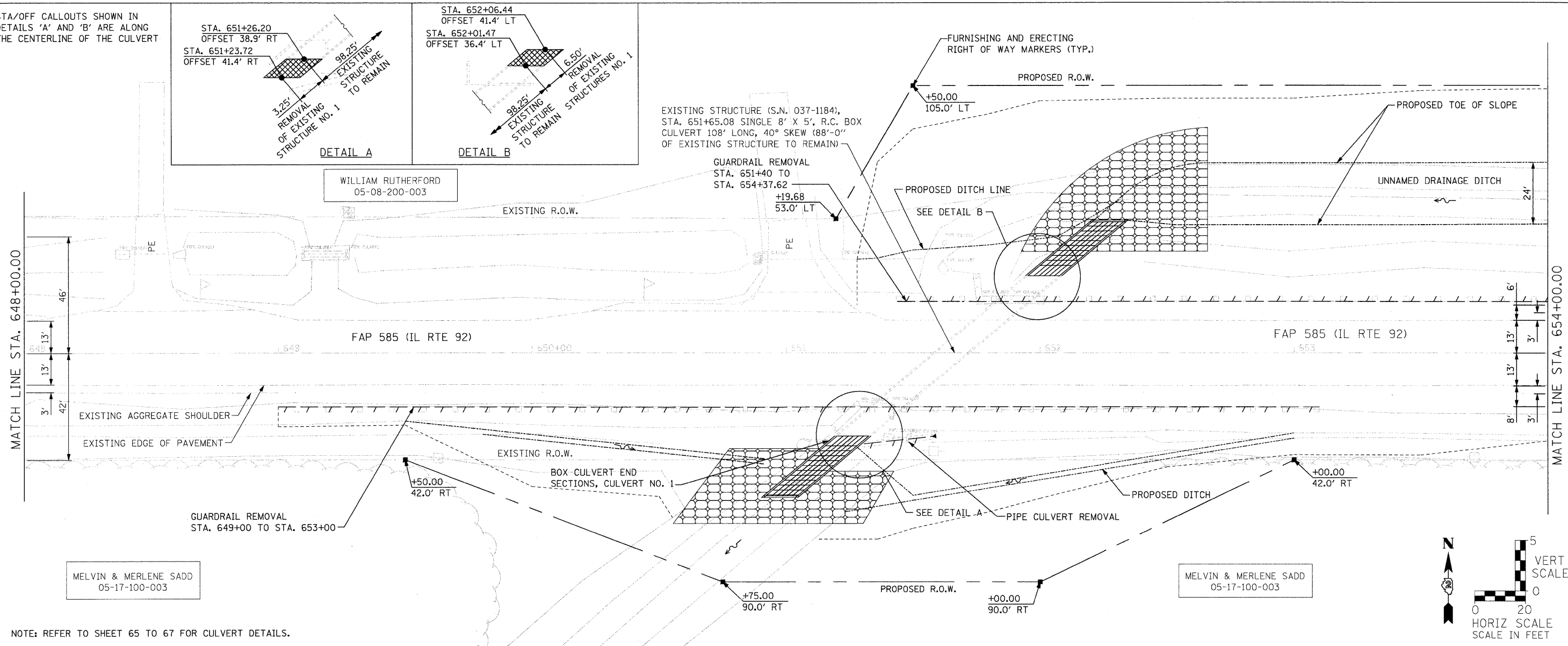

MELVIN & MERLENE SADD
 05-17-100-003

MELVIN & MERLENE SADD
 05-17-100-003

NOTE: REFER TO SHEET 65 TO 67 FOR CULVERT DETAILS.

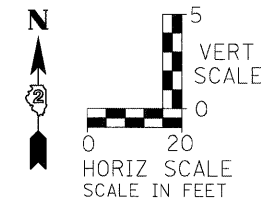

STA. 648+50 TO STA. 667+00
 EARTH EX. = 14,585 CU YD
 EMBANKMENT = 3,465 CU YD
 WASTE = 7,475 CU YD

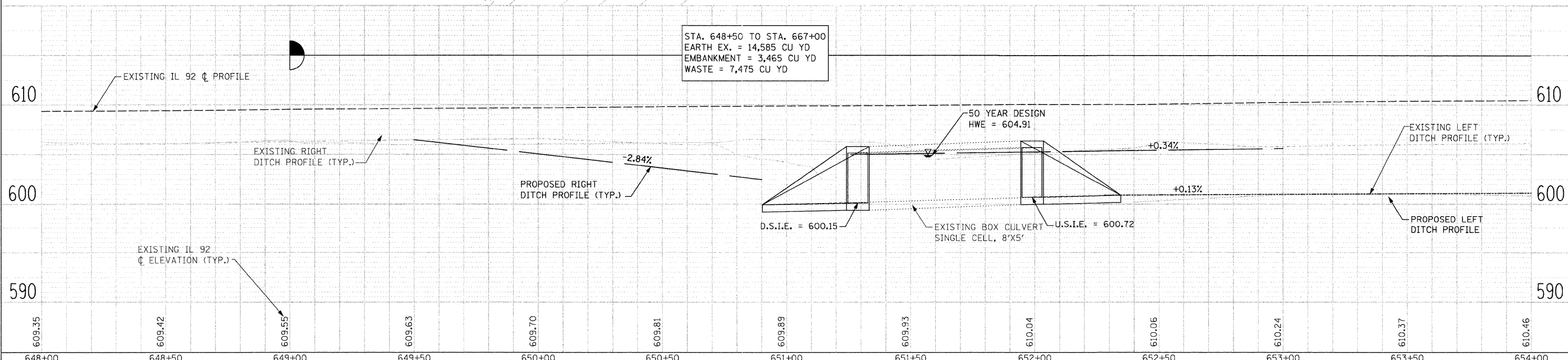

609.35	609.42	609.55	609.63	609.70	609.81	609.89	609.93	610.04	610.06	610.24	610.37	610.46
648+00	648+50	649+00	649+50	650+00	650+50	651+00	651+50	652+00	652+50	653+00	653+50	654+00

1170 SOUTH HOUBOLT ROAD
 JOLIET, ILLINOIS 60431
 (815) 744-4200
STRAND ASSOCIATES, INC. ENGINEERS

USER NAME = brianf	DESIGNED -	REVISED -
CHECKED -	REVISOR -	REVISOR -
PLOT SCALE = 20.0000' / IN.	DRAWN -	REVISOR -
PLOT DATE = 7/19/2011	CHECKED -	REVISOR -

STATE OF ILLINOIS
DEPARTMENT OF TRANSPORTATION

PLAN AND PROFILE - CULVERT /DITCH
 SCALE: AS SHOWN SHEET NO. OF SHEETS STA. 648+00.00 TO STA. 654+00.00

F.A.P. RTE. 585	SECTION 128 BR	COUNTY HENRY	TOTAL SHEETS 106	SHEET NO. 22
CONTRACT NO. 64C20			ILLINOIS FED. AID PROJECT	

PLAN	SURVEYED	BY	DATE
	PLOTTED		
	GRADES CHECKED		
	STRUCTURE NOTATIONS CHECKED		
	NOTE BOOK NO.		
	CADD FILE NAME		

PF	FILE	SURVEYED	BY	DATE
		PLOTTED		
		GRADES CHECKED		
		STRUCTURE NOTATIONS CHECKED		
		NOTE BOOK NO.		
		CADD FILE NAME		

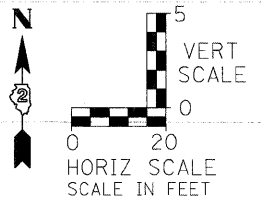
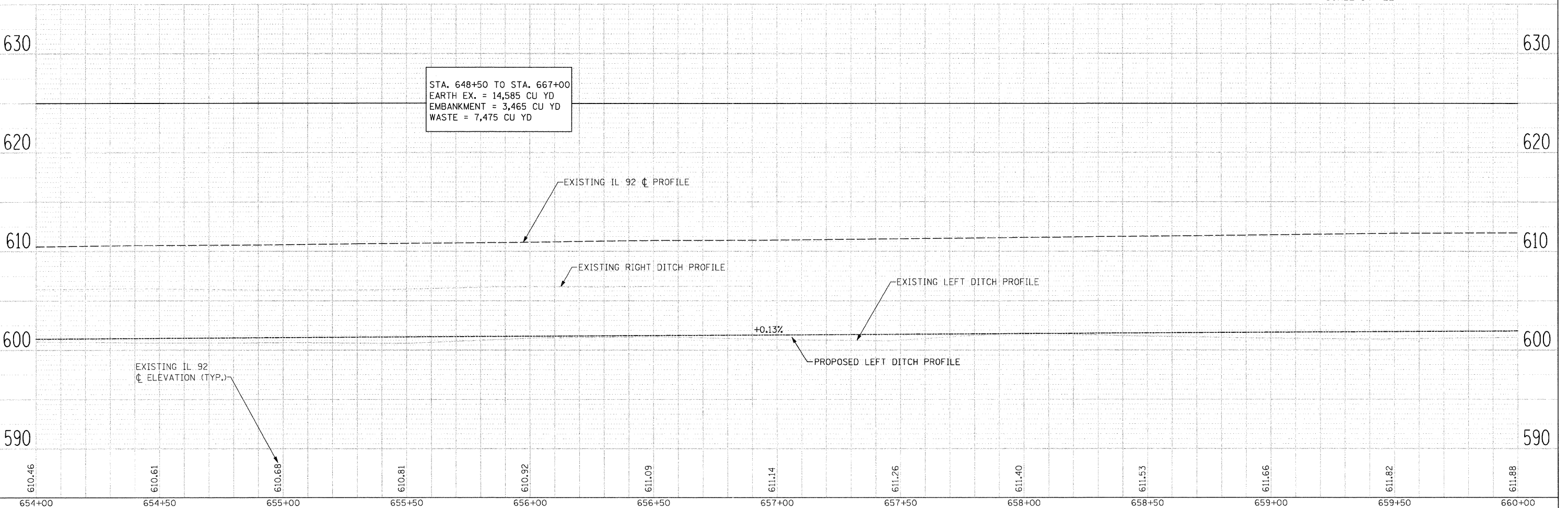
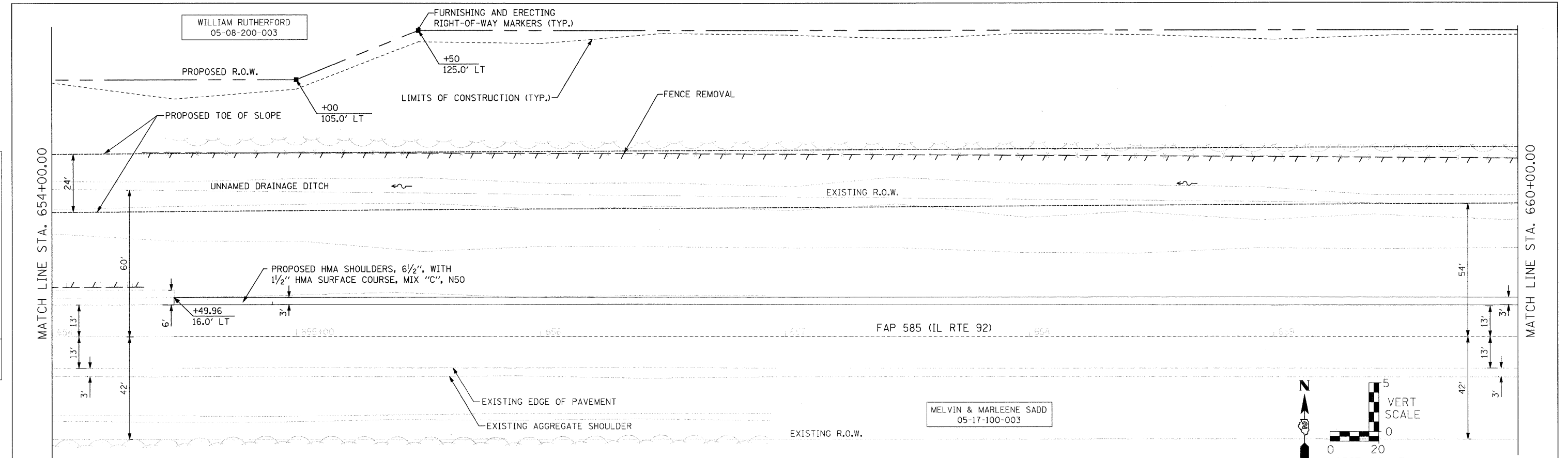

610.46	610.61	610.68	610.81	610.92	611.09	611.14	611.26	611.40	611.53	611.66	611.82	611.88	
654+00	654+50	655+00	655+50	656+00	656+50	657+00	657+50	658+00	658+50	659+00	659+50	660+00	
USER NAME = brianf		DESIGNED -		REVISED -		REVISED -		REVISED -		REVISED -		REVISED -	
CHECKED -		DRAWN -		CHECKED -		REVISED -		REVISED -		REVISED -		REVISED -	
PLOT SCALE = 20,000 ' / IN.		PLOT DATE = 7/19/2011		STATE OF ILLINOIS DEPARTMENT OF TRANSPORTATION		PLAN AND PROFILE - CULVERT / DITCH		SCALE: AS SHOWN		SHEET NO. OF SHEETS		STA. 654+00.00 TO STA. 660+00.00	
F.A.P. RTE. 585		SECTION 128 BR		COUNTY HENRY		TOTAL SHEETS 106		SHEET NO. 23		CONTRACT NO. 64C20		FED. ROAD DIST. NO. 2 ILLINOIS FED. AID PROJECT	

STRAND ASSOCIATES, INC. ENGINEERS
1170 SOUTH HOUBOLT ROAD
JOLIET, ILLINOIS 60431
(815) 744-4200

DATE	
BY	
PLAN	
SURVEYED	
PLOTTED	
ALIGNED	
CHECKED	
NO. 7	
NOTE BOOK	
NO.	
FILE NAME	

DATE	
BY	
FILE	
SURVEYED	
PLOTTED	
GRADES	
CHECKED	
NO. 7	
NOTE BOOK	
NO.	
FILE NAME	

FILE NAME = m:\pa\6300-6399\6346\827\micro\shh1.dwg

WILLIAM RUTHERFORD
05-08-200-003

MELVIN & MARLEENE SADD
05-17-100-003

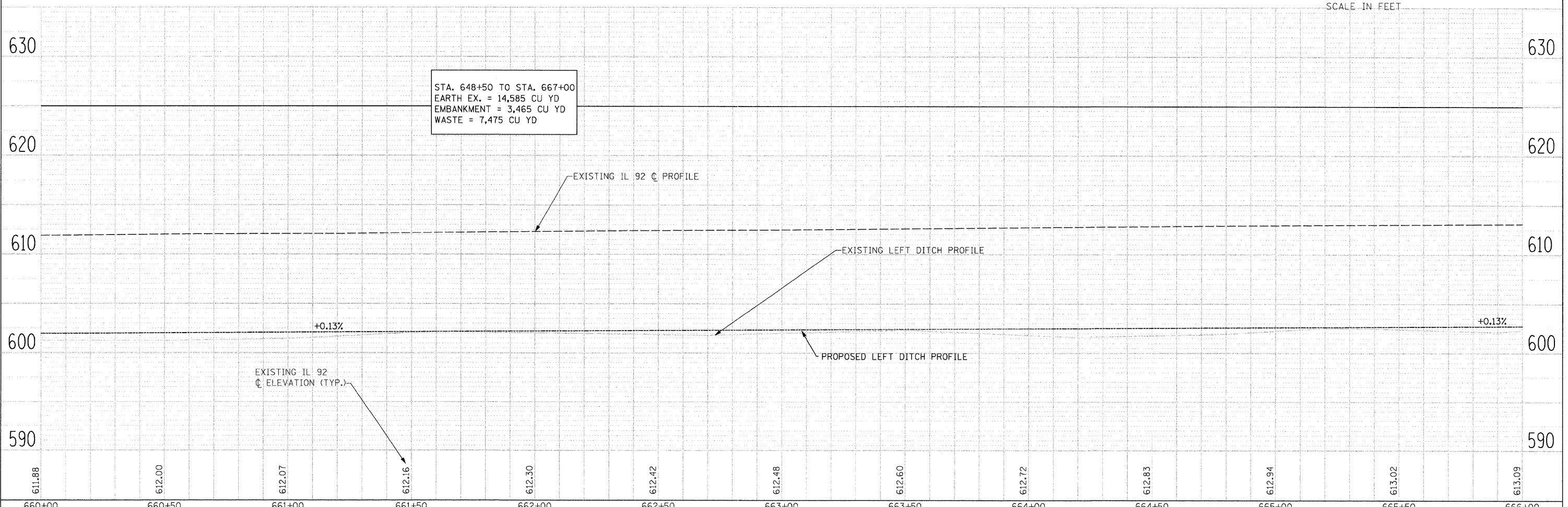
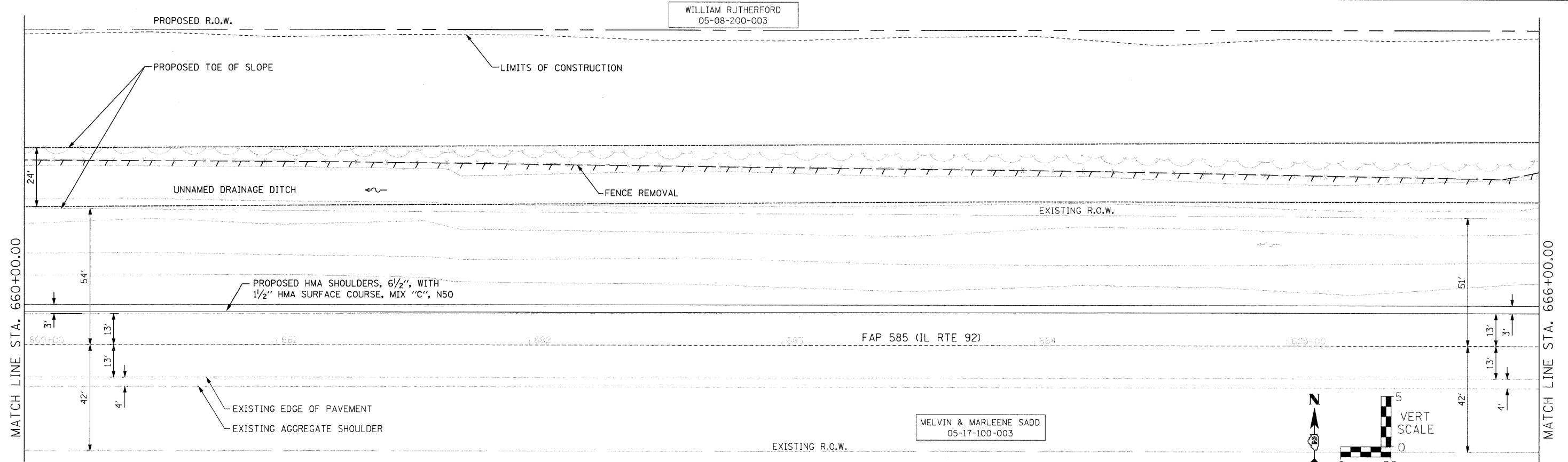

611.88	612.00	612.07	612.16	612.30	612.42	612.48	612.60	612.72	612.83	612.94	613.02	613.09	
660+00	660+50	661+00	661+50	662+00	662+50	663+00	663+50	664+00	664+50	665+00	665+50	666+00	
USER NAME = b-ranf DESIGNED - CHECKED - PLOT SCALE = 20,000 ' / IN. PLOT DATE = 7/19/2011			REVISIONS REVISION NO. 1 REVISION DESCRIPTION REVISION DATE			STATE OF ILLINOIS DEPARTMENT OF TRANSPORTATION			PLAN AND PROFILE - CULVERT /DITCH			F.A.P. RTE. 585 SECTION 128 BR COUNTY HENRY CONTRACT NO. 64C20	TOTAL SHEETS 106 SHEET NO. 24

STRAND ASSOCIATES, INC.
ENGINEERS
1170 SOUTH HOUBOLT ROAD
JOLIET, ILLINOIS 60431
(815) 744-4200

SCALE: AS SHOWN SHEET NO. OF SHEETS STA. 660+00.00 TO STA. 666+00.00
FED. ROAD DIST. NO. 2 ILLINOIS FED. AID PROJECT

PLAN	SURVEYED	CHECKED	DATE
	PLOTTED	ALIGNED	
	NOTE BOOK	FILED	
	NO.	CADD FILE NAME	



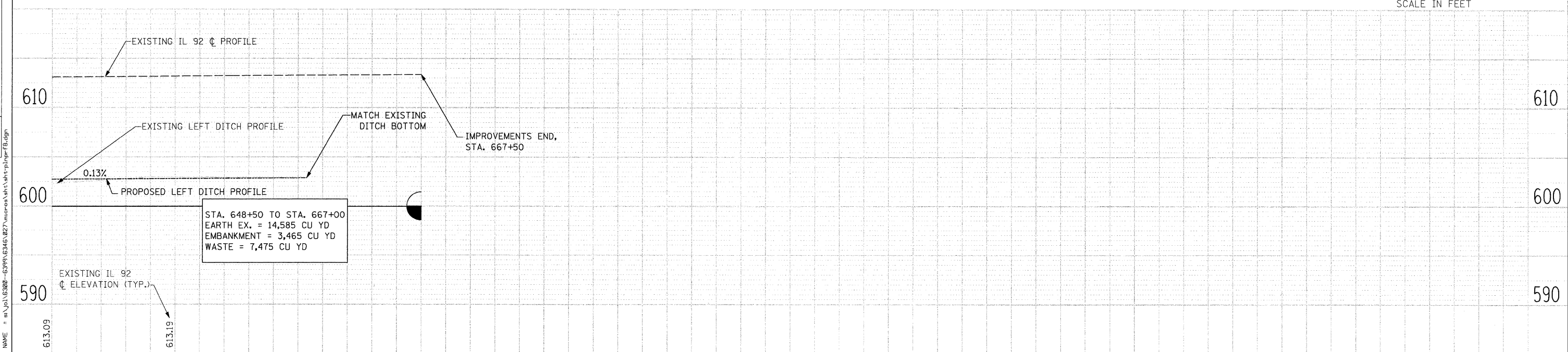
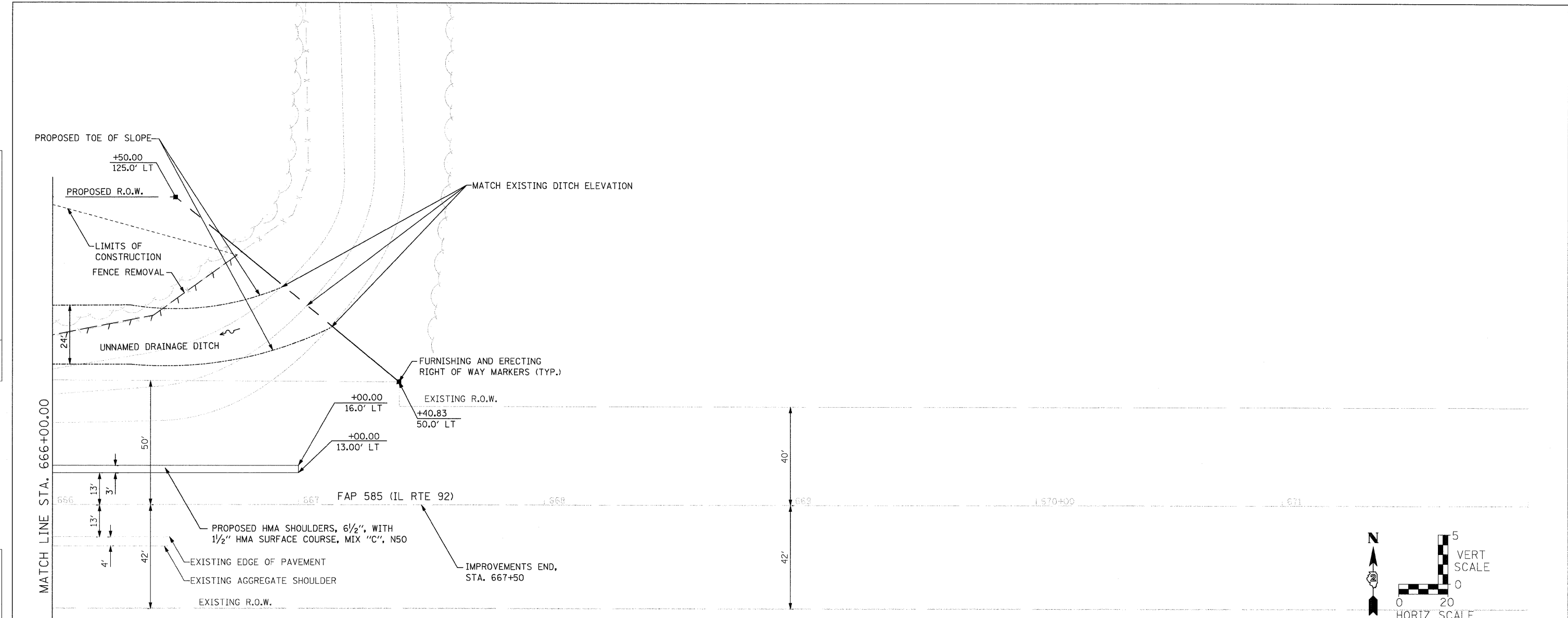



PP	TITLE	SURVEYED	CHECKED	DATE
		GRADES	STRUCTURE	
		NOTES	NOTATIONS	
		NO.	CHKD	



	1170 SOUTH HOUBOLT ROAD JOLIET, ILLINOIS 60431 (815) 744-4200	DESIGNED - CHECKED - DRAWN - CHECKED -	USER NAME = brianf PLOT SCALE = 20.0000' / IN. PLOT DATE = 7/19/2011	REVISED - REVISED - REVISED - REVISED -	STATE OF ILLINOIS DEPARTMENT OF TRANSPORTATION	PLAN AND PROFILE - CULVERT /DITCH				F.A.P. RTE. 585	SECTION 128 BR	COUNTY HENRY	TOTAL SHEETS 106	SHEET NO. 25
	SCALE: AS SHOWN SHEET NO. OF SHEETS STA. TO STA.					CONTRACT NO. 64C20								
						ILLINOIS FED. AID PROJECT								

FILE NAME = m:\j\163800-6399\6346\027\macro\wh\tr\plan\p18.dgn

LEGEND:

	= WORK ZONE
	= TEMPORARY WIDENING
	= SIGN
	= TYPE III BARRICADE
	= DRUM WITH STEADY BURNING LIGHTS
	= TRAFFIC SIGNAL

GENERAL NOTES:

1. PLACEMENT OF TEMPORARY CONCRETE BARRIERS, TEMPORARY IMPACT ATTENUATORS, TEMPORARY SIGNALS, DRUMS WITH STEADY BURNING LIGHTS, AND STOP BARS SHALL BE AS SHOWN.
2. PLACEMENT OF OTHER TRAFFIC CONTROL ITEMS NOT SHOWN ON THE DRAWINGS SHALL BE DONE PER STANDARD 701321.
3. IMPROVEMENTS AT S.N. 037-1184 CAN BE DONE CONCURRENTLY WITH WORK AT S.N. 037-0174.

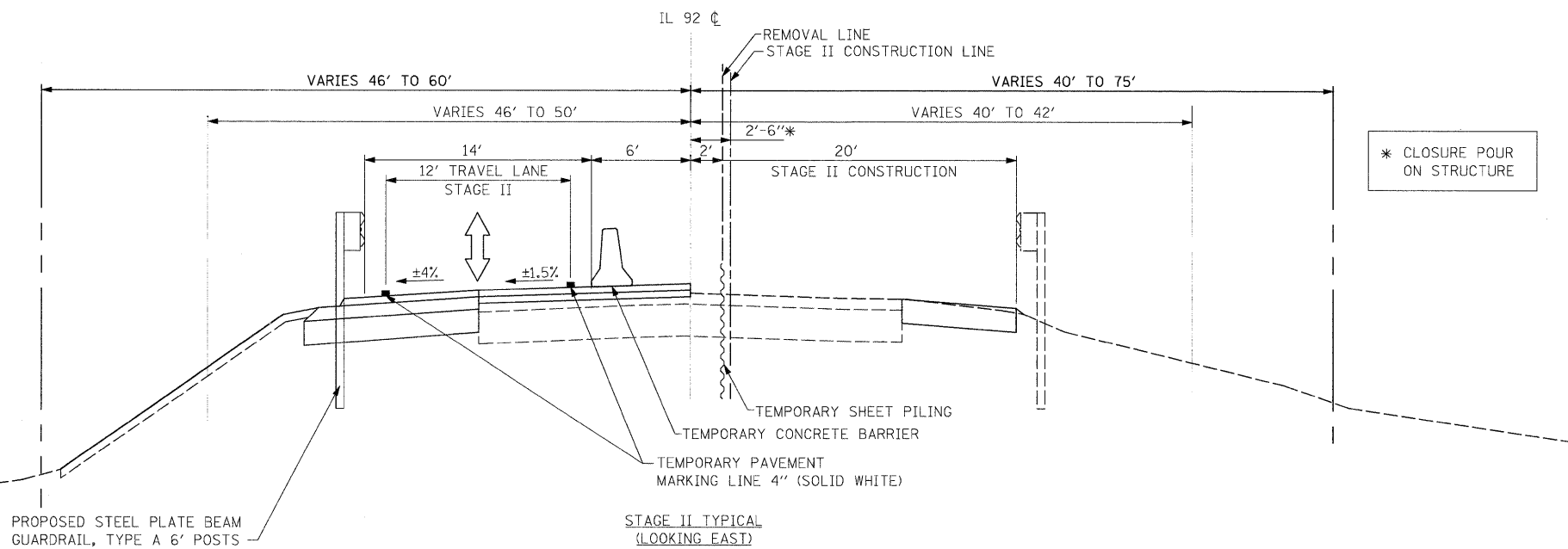
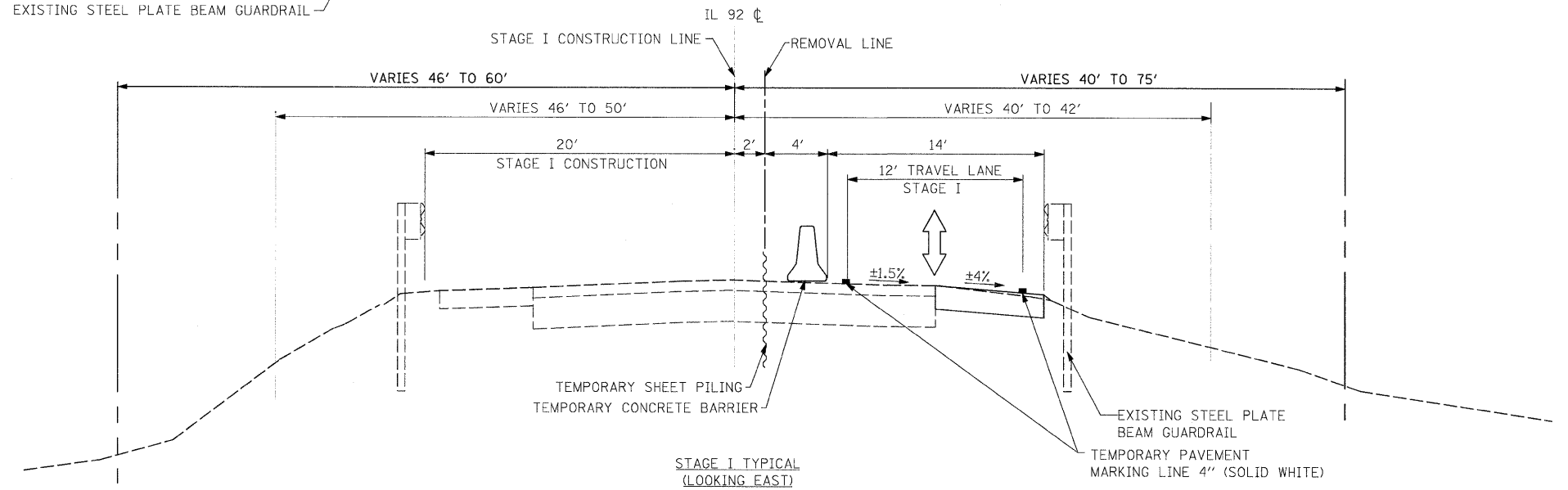
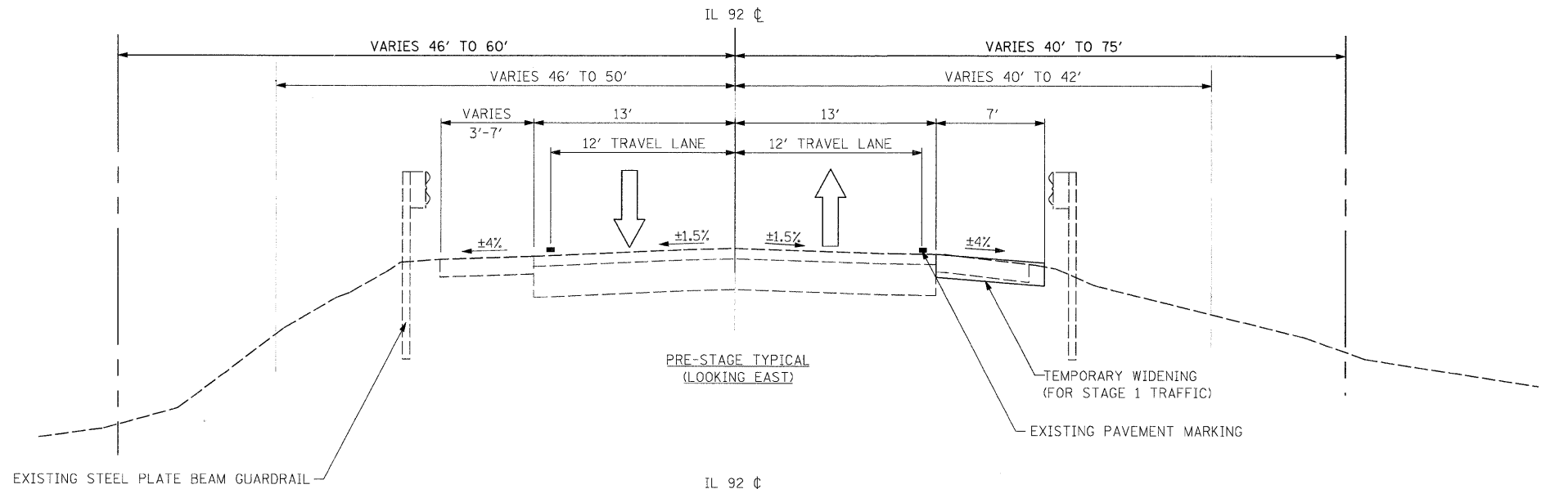

* CLOSURE POUR ON STRUCTURE

FILE NAME = s:\j\163800-6399\6346\027\mcoroa\stg\staging-notes.dgn



1170 SOUTH HOUBOLT ROAD JOLIET, ILLINOIS 60431 (815) 744-4200	USER NAME = brianf	DESIGNED -	REVISED -
PLOT SCALE = 20.0000' / IN.	CHECKED -	REVISED -	REVISED -
PLOT DATE = 7/19/2011	DATE -	REVISED -	REVISED -

**STATE OF ILLINOIS
DEPARTMENT OF TRANSPORTATION**

SUGGESTED MAINTENANCE OF TRAFFIC - NOTES AND TYPICAL SECTIONS

SCALE: AS SHOWN	SHEET NO.	OF	SHEETS	STA.	TO STA.
-----------------	-----------	----	--------	------	---------

F.A.P. RTE. 585	SECTION 128 BR	COUNTY HENRY	TOTAL SHEETS 106	SHEET NO. 26
CONTRACT NO. 64C20				
FED. ROAD DIST. NO. 2 ILLINOIS FED. AID PROJECT				

PRE-STAGE

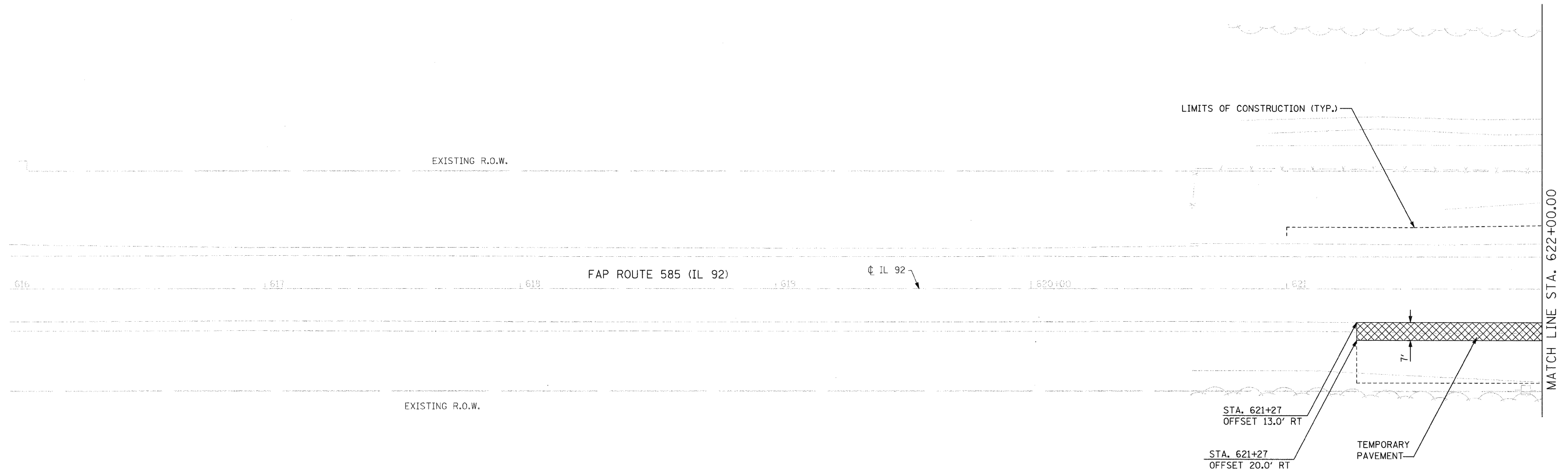

PRE-STAGE NOTES:

1. USE STANDARD 701326 FOR TEMPORARY WIDENING.
2. INSTALL TEMPORARY WIDENING 7' WIDE FROM STA. 621+27 TO STA. 629+71. AT AREAS WHERE EXISTING GUARDRAIL/PARAPET WALL ARE INSTALLED, INSTALL TEMPORARY WIDENING TO THE FACE OF THE GUARDRAIL/PARAPET WALL.

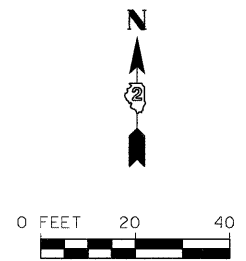

FILE NAME = s:\p1\6390--6395\6346\027\micro\sh\shtr-stage\pl-1.dgn

	1170 SOUTH HOUBOLT ROAD JOLIET, ILLINOIS 60431 (815) 744-4200	USER NAME = brianf	DESIGNED -	REVISED -	STATE OF ILLINOIS DEPARTMENT OF TRANSPORTATION	SUGGESTED MAINTENANCE OF TRAFFIC			F.A.P. RTE. 585	SECTION 128 BR	COUNTY HENRY	TOTAL SHEETS 106	SHEET NO. 27
	PLOT SCALE = 20,0000' / IN.	CHECKED -	REVISED -	CONTRACT NO. 64C20									
	PLOT DATE = 7/21/2011	DATE -	REVISED -	SCALE: AS SHOWN SHEET NO. OF SHEETS STA. 616+00 TO STA. 622+00			FED. ROAD DIST. NO. 2 ILLINOIS FED. AID PROJECT						

PRE-STAGE

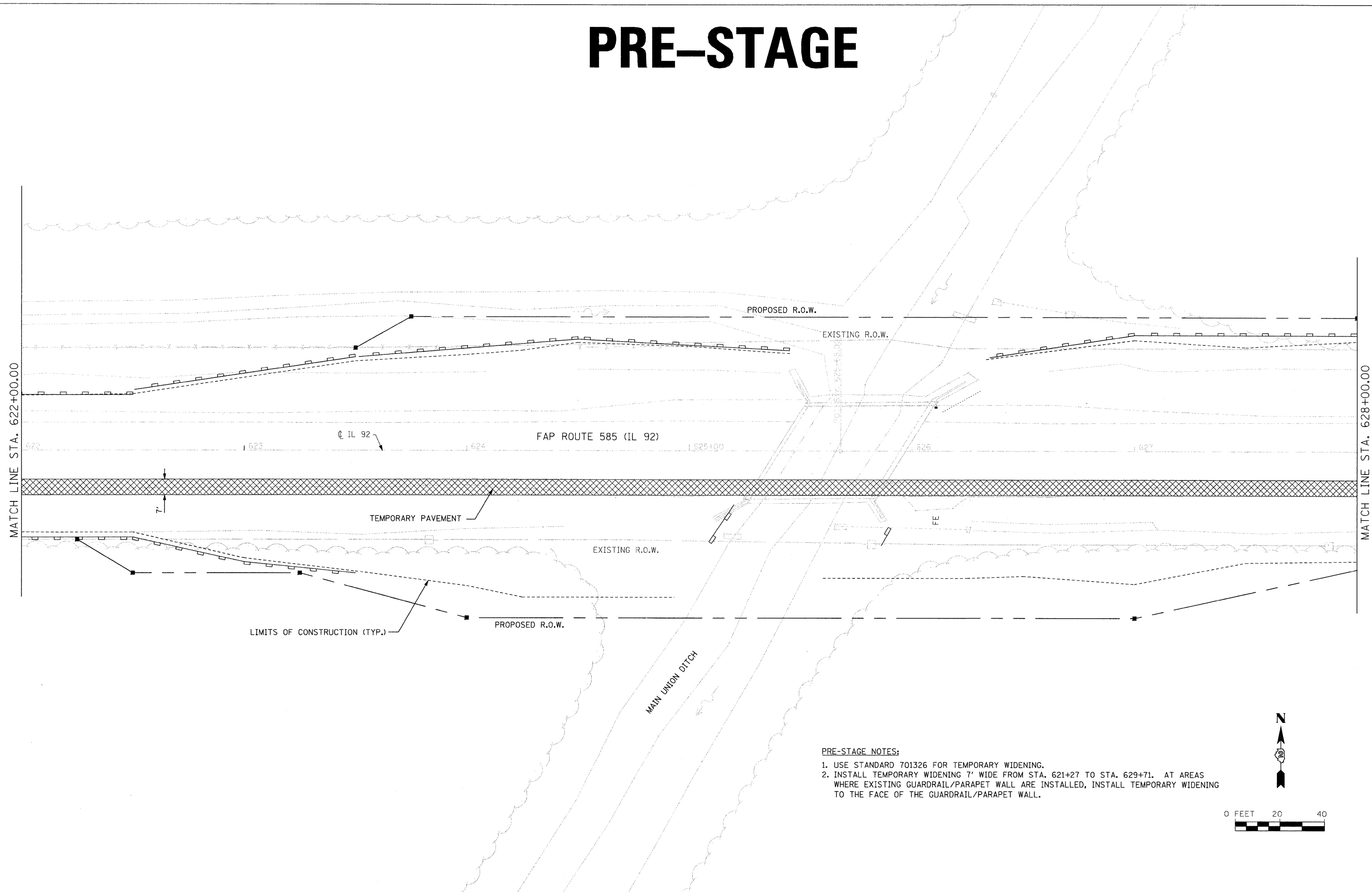

PRE-STAGE NOTES:

1. USE STANDARD 701326 FOR TEMPORARY WIDENING.
2. INSTALL TEMPORARY WIDENING 7' WIDE FROM STA. 621+27 TO STA. 629+71. AT AREAS WHERE EXISTING GUARDRAIL/PARAPET WALL ARE INSTALLED, INSTALL TEMPORARY WIDENING TO THE FACE OF THE GUARDRAIL/PARAPET WALL.

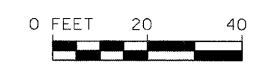

FILE NAME = s:\vol_16300-6395\6346\027\micross\hht\hht-2.dgn

STRAND ASSOCIATES, INC.
ENGINEERS

1170 SOUTH HOUBOLT ROAD
JOLIET, ILLINOIS 60431
(815) 744-4200

USER NAME = brianf	DESIGNED -	REVISED -
PLOT SCALE = 20.0000' / IN.	DRAWN -	REVISED -
PLOT DATE = 7/21/2011	CHECKED -	REVISED -
	DATE -	REVISED -

**STATE OF ILLINOIS
DEPARTMENT OF TRANSPORTATION**

SUGGESTED MAINTENANCE OF TRAFFIC			
SCALE: AS SHOWN	SHEET NO. OF SHEETS	STA. 622+00 TO STA. 628+00	

F.A.P. RTE. 585	SECTION 128 BR	COUNTY HENRY	TOTAL SHEETS 106	SHEET NO. 28
CONTRACT NO. 64C20				
FED. ROAD DIST. NO. 2 ILLINOIS FED. AID PROJECT				

PRE-STAGE

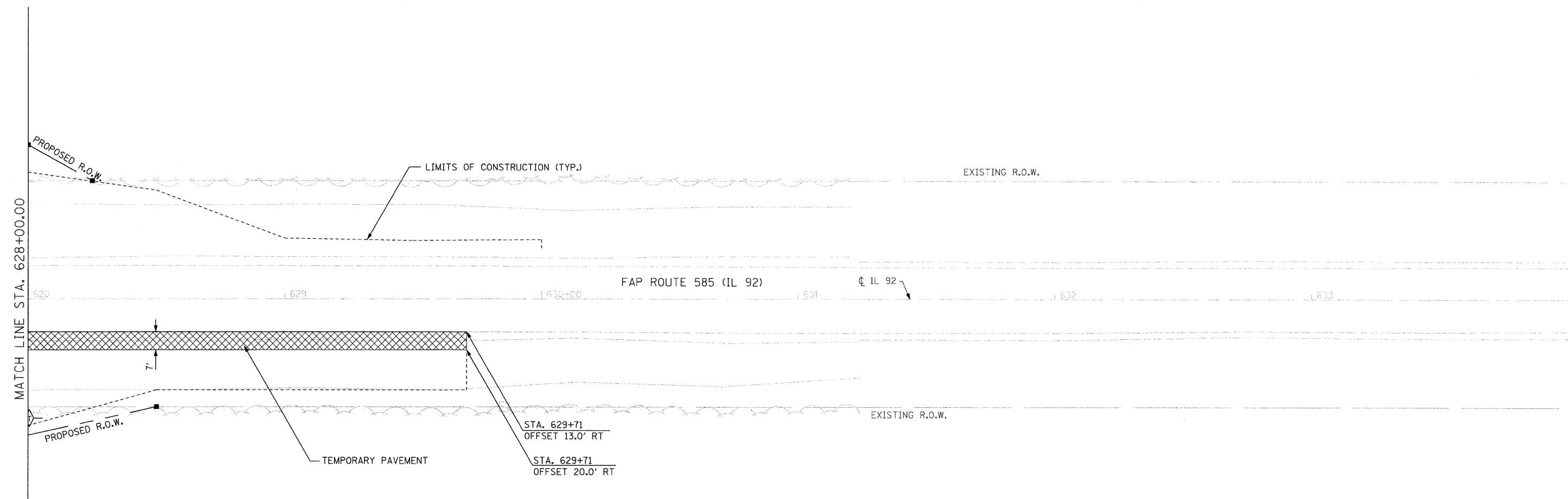

PRE-STAGE NOTES:

1. USE STANDARD 701326 FOR TEMPORARY WIDENING.
2. INSTALL TEMPORARY WIDENING 7' WIDE FROM STA. 621+27 TO STA. 629+71. AT AREAS WHERE EXISTING GUARDRAIL/PARAPET WALL ARE INSTALLED, INSTALL TEMPORARY WIDENING TO THE FACE OF THE GUARDRAIL/PARAPET WALL.

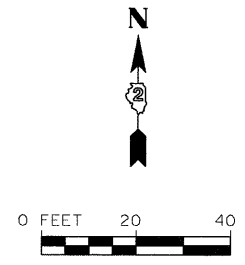

FILE NAME = s:\p\6300-6399\6346\027\micro\sheet\stg\stg.rvt-3.dgn

STRAND ASSOCIATES, INC.
ENGINEERS
1170 SOUTH HOUBOLT ROAD
JOLIET, ILLINOIS 60431
(815) 744-4200

USER NAME = brianf	DESIGNED -	REVISED -
PLOT SCALE = 20.0000' / IN.	DRAWN -	REVISED -
PLOT DATE = 7/21/2011	CHECKED -	REVISED -
	DATE -	REVISED -

**STATE OF ILLINOIS
DEPARTMENT OF TRANSPORTATION**

SUGGESTED MAINTENANCE OF TRAFFIC			
SCALE: AS SHOWN	SHEET NO.	OF SHEETS	STA. 628+00 TO STA. 634+00

F.A.P. RTE.	SECTION	COUNTY	TOTAL SHEETS	SHEET NO.
585	128 BR	HENRY	106	29
CONTRACT NO. 64C20				
FED. ROAD DIST. NO. 2 ILLINOIS FED. AID PROJECT				

STAGE 1

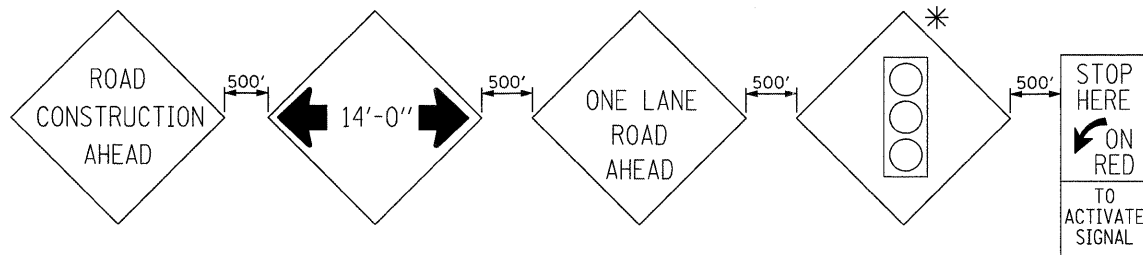
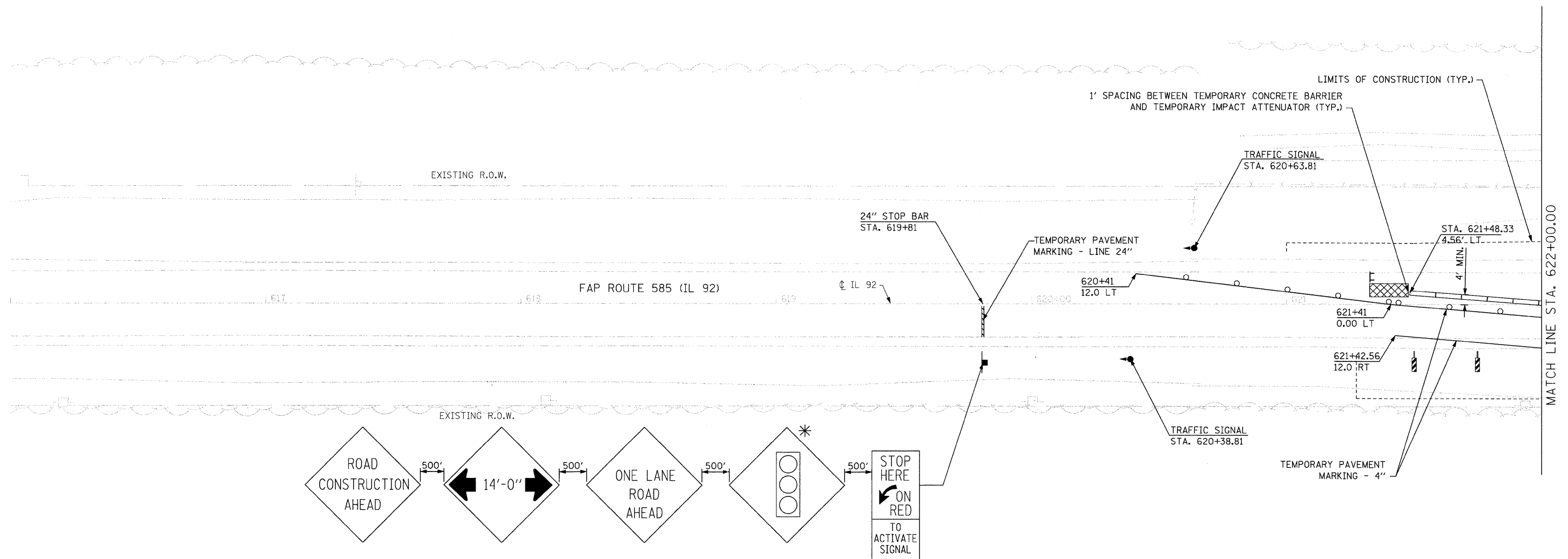

* SIGN SHALL BE INSTALLED ON BOTH THE NORTH AND SOUTH SIDE OF IL 92 PER STANDARD 701321

STAGE 1 NOTES:

1. INSTALL TRAFFIC CONTROL AND TEMPORARY TRAFFIC SIGNALS ACCORDING TO STANDARD 701321.
2. DRIVE TEMPORARY SHEET PILING AS REQUIRED.
3. REMOVE THE NORTH SIDE EXISTING BRIDGE, APPROACH, ABUTMENT, AND PIERS.
4. CONSTRUCT THE NORTH SIDE OF BRIDGE INCLUDING PROPOSED RIP-RAP AND EARTHWORK.
5. REMOVE EXISTING HMA SURFACE ON THE WESTBOUND LANE.
6. INSTALL PROPOSED HMA SHOULDERS AND HMA LEVELING BINDER ON THE WESTBOUND LANE.
7. INSTALL THE PROPOSED GUARDRAIL ON THE NORTH SIDE.
8. FOR SHOULDER CONSTRUCTION FROM STA. 621+00 TO STA. 623+00 AND FROM STA. 628+00 TO STA. 630+00 USE STANDARD 701011.

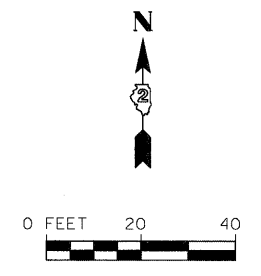

FILE NAME = s:\01\6300--6395\6346\027\micro\sh\st\stage1.dgn



USER NAME = b-1anf	DESIGNED -	REVISED -
PLOT SCALE = 20,0000' / IN.	DRAWN -	REVISED -
PLOT DATE = 7/21/2011	CHECKED -	REVISED -
	DATE -	REVISED -

**STATE OF ILLINOIS
DEPARTMENT OF TRANSPORTATION**

SUGGESTED MAINTENANCE OF TRAFFIC

SCALE: AS SHOWN SHEET NO. OF SHEETS STA. 616+00 TO STA. 622+00

F.A.P. RTE.	SECTION	COUNTY	TOTAL SHEETS	SHEET NO.
585	128 BR	HENRY	106	30
CONTRACT NO. 64C20			ILLINOIS FED. AID PROJECT	

STAGE 1

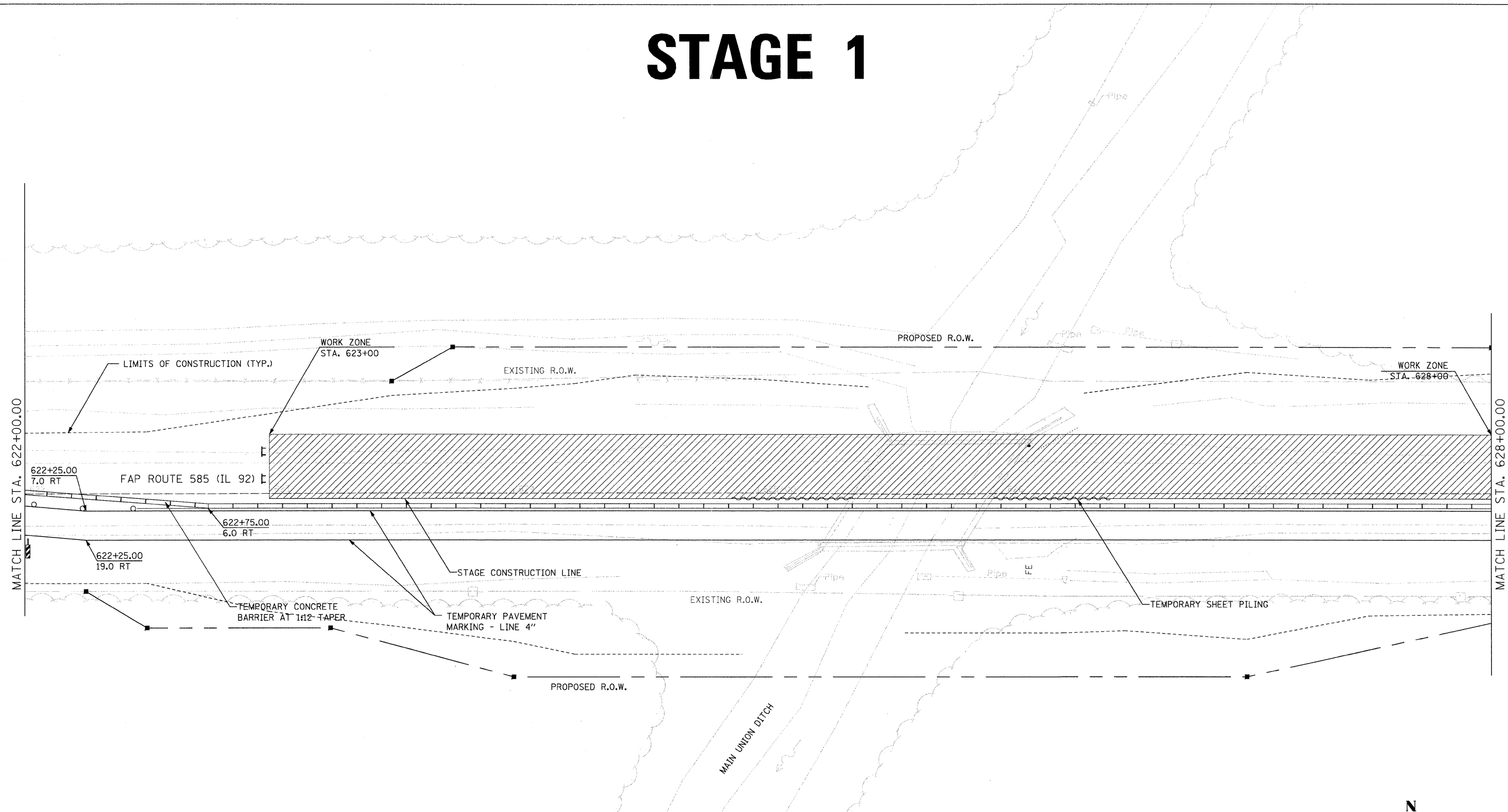

STAGE 1 NOTES:

1. INSTALL TRAFFIC CONTROL AND TEMPORARY TRAFFIC SIGNALS ACCORDING TO STANDARD 701321.
2. DRIVE TEMPORARY SHEET PILING AS REQUIRED.
3. REMOVE THE NORTH SIDE EXISTING BRIDGE, APPROACH, ABUTMENT, AND PIERS.
4. CONSTRUCT THE NORTH SIDE OF BRIDGE INCLUDING PROPOSED RIP-RAP AND EARTHWORK.
5. REMOVE EXISTING HMA SURFACE ON THE WESTBOUND LANE.
6. INSTALL PROPOSED HMA SHOULDERS AND HMA LEVELING BINDER ON THE WESTBOUND LANE.
7. INSTALL THE PROPOSED GUARDRAIL ON THE NORTH SIDE.
8. FOR SHOULDER CONSTRUCTION FROM STA. 621+00 TO STA. 623+00 AND FROM STA. 628+00 TO STA. 630+00 USE STANDARD 701011.

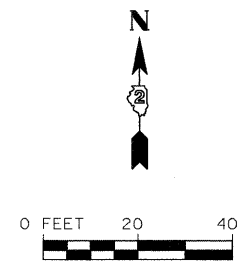

FILE NAME = s:\p\6300-6399\6346\27\micro\st1\st1-stage1-2.dgn



USER NAME = brianf	DESIGNED -	REVISED -
PLDT SCALE = 20,000' / IN.	DRAWN -	REVISED -
PLDT DATE = 7/21/2011	CHECKED -	REVISED -
	DATE -	REVISED -

**STATE OF ILLINOIS
DEPARTMENT OF TRANSPORTATION**

SUGGESTED MAINTENANCE OF TRAFFIC

SCALE: AS SHOWN SHEET NO. OF SHEETS STA. 622+00 TO STA. 628+00

F.A.P. RTE.	SECTION	COUNTY	TOTAL SHEETS	SHEET NO.
585	128 BR	HENRY	106	31
CONTRACT NO. 64C20				
FED. ROAD DIST. NO. 2 ILLINOIS FED. AID PROJECT				

STAGE 1

* SIGN SHALL BE INSTALLED ON BOTH THE NORTH AND SOUTH SIDE OF IL 92 PER STANDARD 701321

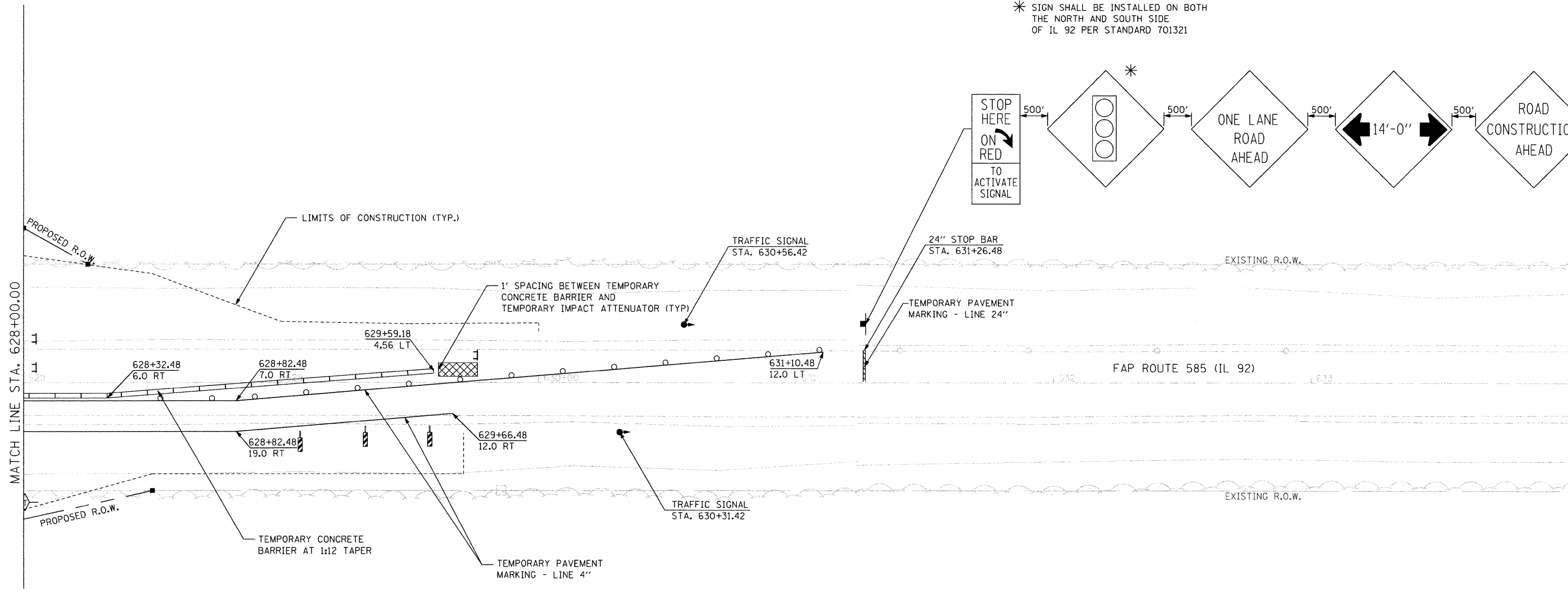
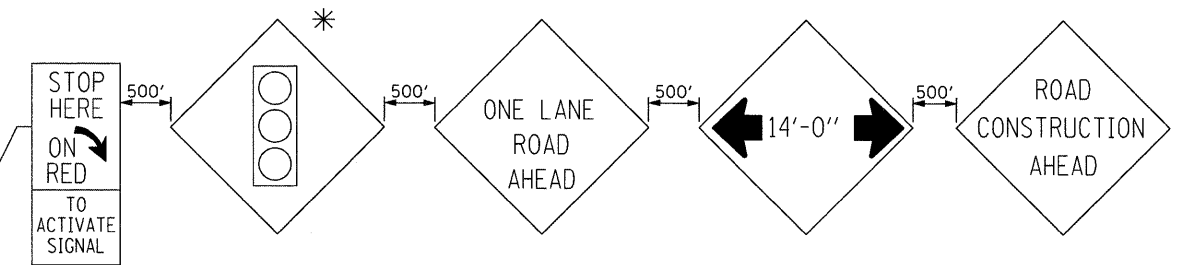

STAGE 1 NOTES:

1. INSTALL TRAFFIC CONTROL AND TEMPORARY TRAFFIC SIGNALS ACCORDING TO STANDARD 701321.
2. DRIVE TEMPORARY SHEET PILING AS REQUIRED.
3. REMOVE THE NORTH SIDE EXISTING BRIDGE, APPROACH, ABUTMENT, AND PIERS.
4. CONSTRUCT THE NORTH SIDE OF BRIDGE INCLUDING PROPOSED RIP-RAP AND EARTHWORK.
5. REMOVE EXISTING HMA SURFACE ON THE WESTBOUND LANE.
6. INSTALL PROPOSED HMA SHOULDERS AND HMA LEVELING BINDER ON THE WESTBOUND LANE.
7. INSTALL THE PROPOSED GUARDRAIL ON THE NORTH SIDE.
8. FOR SHOULDER CONSTRUCTION FROM STA. 621+00 TO STA. 623+00 AND FROM STA. 628+00 TO STA. 630+00 USE STANDARD 701011.

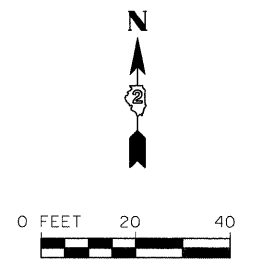

FILE NAME = s:\pl\63008-63995\6346\027\micross\st1\st1.dgn



1170 SOUTH HOUBOLT ROAD JOLIET, ILLINOIS 60431 (815) 744-4200	USER NAME = brianf	DESIGNED -	REVISED -
	PLLOT SCALE = 20,0000' / IN.	DRAWN -	REVISED -
	PLLOT DATE = 7/21/2011	CHECKED -	REVISED -
		DATE -	REVISED -

**STATE OF ILLINOIS
DEPARTMENT OF TRANSPORTATION**

SUGGESTED MAINTENANCE OF TRAFFIC			
SCALE: AS SHOWN	SHEET NO.	OF SHEETS	STA. 628+00 TO STA. 634+00

F.A.P. RTE.	SECTION	COUNTY	TOTAL SHEETS	SHEET NO.
585	128 BR	HENRY	106	32
CONTRACT NO. 64C20				
FED. ROAD DIST. NO. 2 ILLINOIS FED. AID PROJECT				

STAGE 2

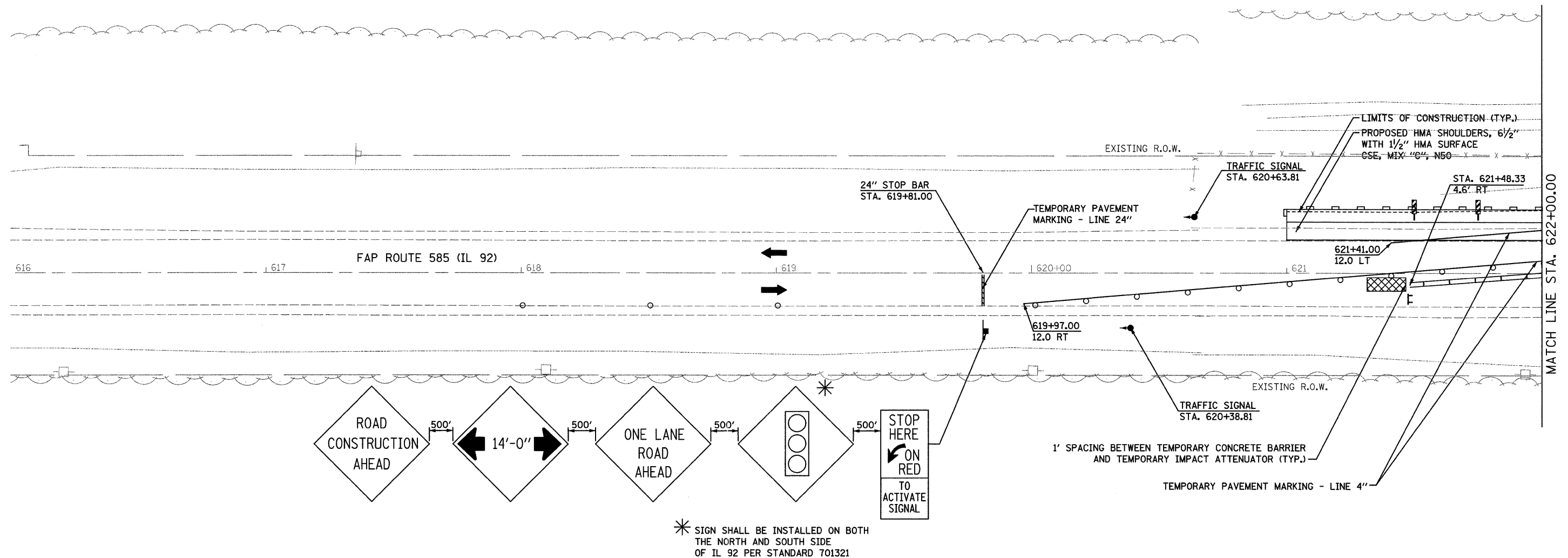

STAGE 2 NOTES:

1. RELOCATE TRAFFIC CONTROL AND TEMPORARY TRAFFIC SIGNALS ACCORDING TO STAGE 2 MAINTENANCE OF TRAFFIC DETAILS AND STANDARD 701321.
2. REMOVE THE SOUTH SIDE EXISTING BRIDGE, APPROACH, ABUTMENT, AND PIERS.
3. CONSTRUCT THE SOUTH SIDE OF BRIDGE INCLUDING PROPOSED RIP-RAP AND EARTHWORK.
4. REMOVE EXISTING HMA SURFACE ON THE EASTBOUND LANE.
5. INSTALL PROPOSED HMA SHOULDERS AND HMA LEVELING BINDER ON THE EASTBOUND LANE.
6. INSTALL THE PROPOSED GUARDRAIL ON THE NORTH SIDE.
7. COMPLETE CLOSURE POUR ON BRIDGE.

STAGE 3 NOTES:

1. REMOVE TRAFFIC CONTROL AND TEMPORARY TRAFFIC SIGNALS FROM STAGE III MAINTENANCE OF TRAFFIC DETAILS AND STANDARD 701321.
2. INSTALL PROPOSED HMA SURFACE COURSE.
3. INSTALL PERMANENT PAVEMENT MARKINGS.

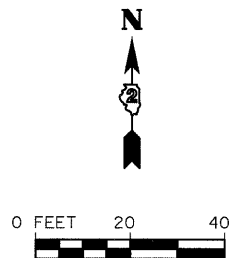

FILE NAME = S:\JOL\6300-6395\6346\027\Map\oa\Sta\int-stageing3-1.dgn

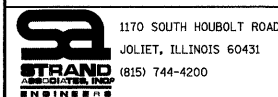

1170 SOUTH HOUBOLT ROAD JOLIET, ILLINOIS 60431 (815) 744-4200	USER NAME = raymondk	DESIGNED -	REVISED -
	PLOT SCALE = 20,0000' / IN.	DRAWN -	REVISED -
	PLOT DATE = 7/21/2011	CHECKED -	REVISED -
		DATE -	REVISED -

**STATE OF ILLINOIS
DEPARTMENT OF TRANSPORTATION**

SUGGESTED MAINTENANCE OF TRAFFIC

SCALE: AS SHOWN SHEET NO. OF SHEETS STA. 616+00 TO STA. 622+00

F.A.P. RTE.	SECTION	COUNTY	TOTAL SHEETS	SHEET NO.
585	128 BR	HENRY	106	33
CONTRACT NO. 64C20				
FED. ROAD DIST. NO. 2 ILLINOIS FED. AID PROJECT				

STAGE 2

PROPOSED STRUCTURE (S.N. 037-0174)
 STA. 625+67.67
 SINGLE SPAN STEEL GIRDER,
 SKEW 32°,
 91'- 5/4" BK. TO BK. ABUTMENTS
 (CONSTRUCTED DURING STAGE 1)

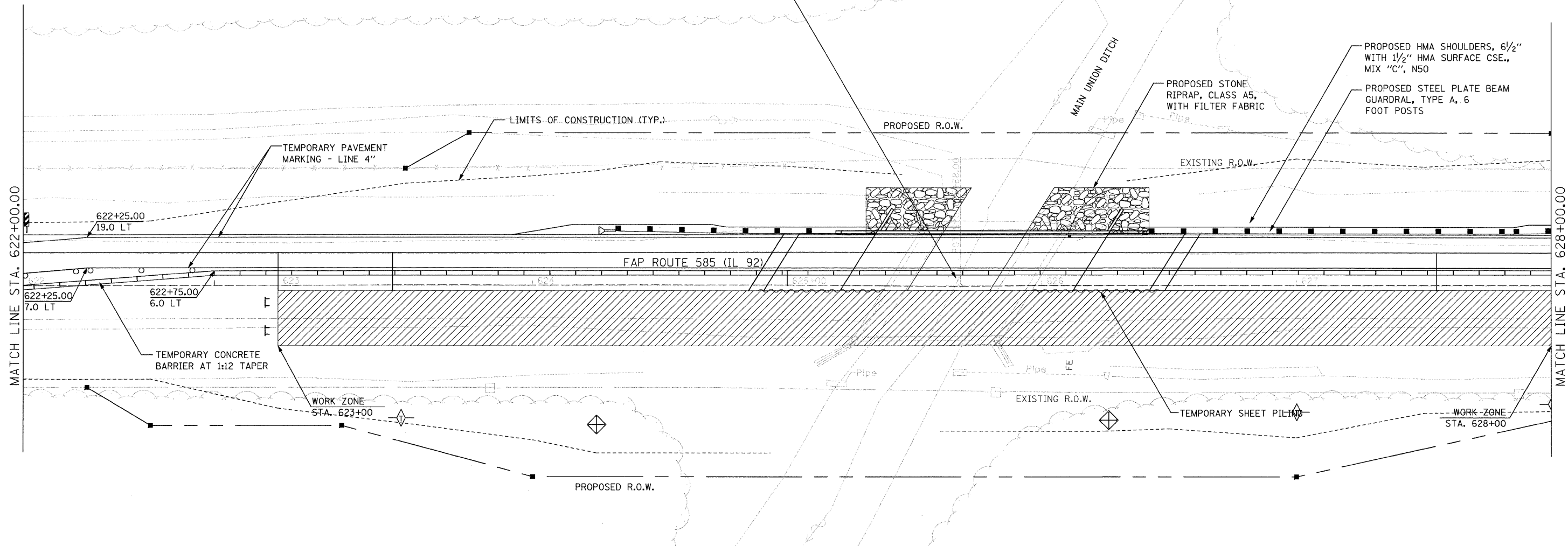

STAGE 2 NOTES:

1. RELOCATE TRAFFIC CONTROL AND TEMPORARY TRAFFIC SIGNALS ACCORDING TO STAGE 2 MAINTENANCE OF TRAFFIC DETAILS AND STANDARD 701321.
2. REMOVE THE SOUTH SIDE EXISTING BRIDGE, APPROACH, ABUTMENT, AND PIERS.
3. CONSTRUCT THE SOUTH SIDE OF BRIDGE INCLUDING PROPOSED RIP-RAP AND EARTHWORK.
4. REMOVE EXISTING HMA SURFACE ON THE EASTBOUND LANE.
5. INSTALL PROPOSED HMA SHOULDERS AND HMA LEVELING BINDER ON THE EASTBOUND LANE.
6. INSTALL THE PROPOSED GUARDRAIL ON THE NORTH SIDE.
7. COMPLETE CLOSURE POUR ON BRIDGE.

STAGE 3 NOTES:

1. REMOVE TRAFFIC CONTROL AND TEMPORARY TRAFFIC SIGNALS FROM STAGE III MAINTENANCE OF TRAFFIC DETAILS AND STANDARD 701321.
2. INSTALL PROPOSED HMA SURFACE COURSE.
3. INSTALL PERMANENT PAVEMENT MARKINGS.

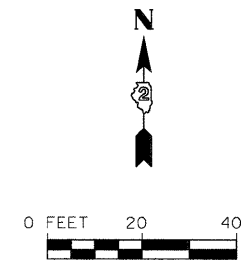

FILE NAME = s:\p1\63008-63919\63416\027\microca\st\st\st\stage2.dgn

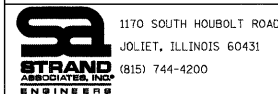

USER NAME = brjanf	DESIGNED -	REVISED -
PLOT SCALE = 20,0000' / IN.	DRAWN -	REVISED -
PLOT DATE = 7/21/2011	CHECKED -	REVISED -
	DATE -	REVISED -

**STATE OF ILLINOIS
 DEPARTMENT OF TRANSPORTATION**

SUGGESTED MAINTENANCE OF TRAFFIC

SCALE: AS SHOWN SHEET NO. OF SHEETS STA. 622+00 TO STA. 628+00

F.A.P. RTE.	SECTION	COUNTY	TOTAL SHEETS	SHEET NO.
585	128 BR	HENRY	106	34
CONTRACT NO. 64C20				
FED. ROAD DIST. NO. 2 ILLINOIS FED. AID PROJECT				

STAGE 2

* SIGN SHALL BE INSTALLED ON BOTH THE NORTH AND SOUTH SIDE OF IL 92 PER STANDARD 701321

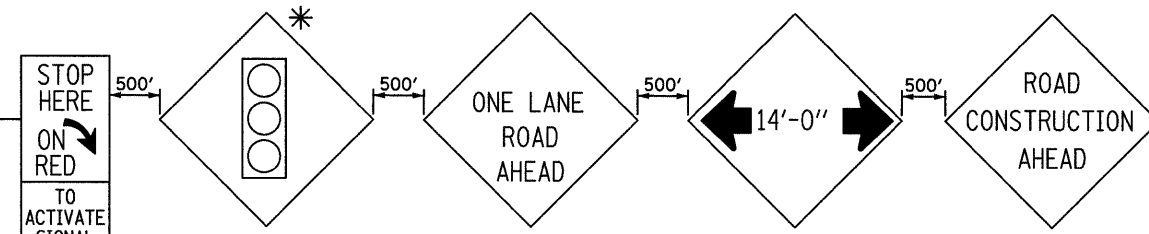
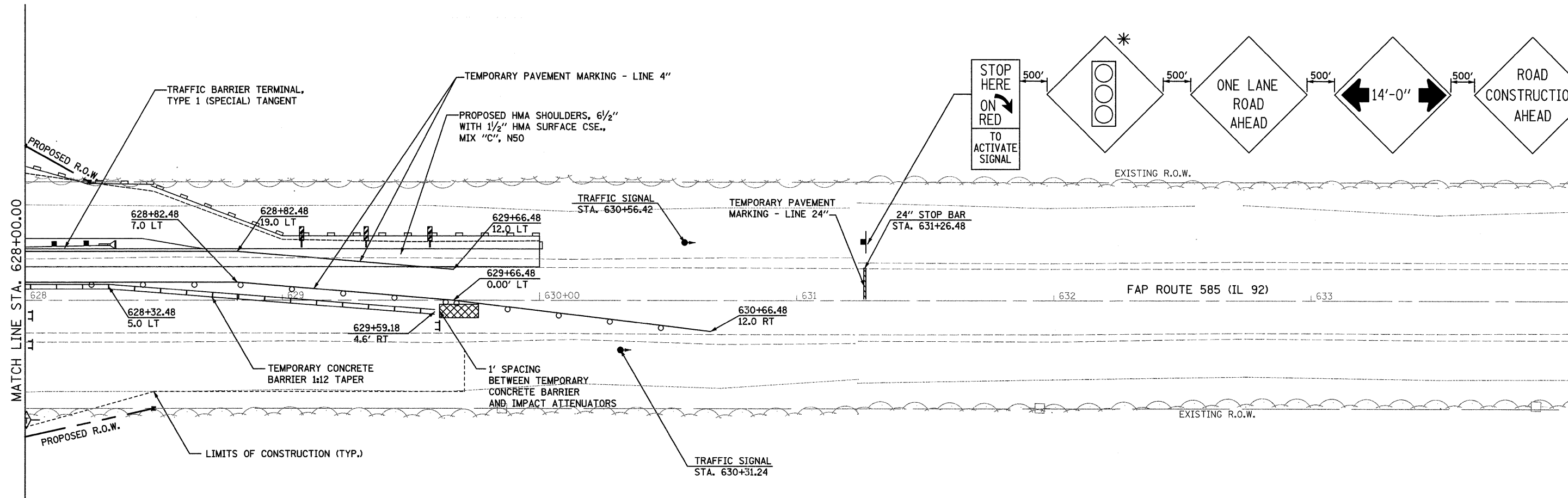

STAGE 2 NOTES:

1. RELOCATE TRAFFIC CONTROL AND TEMPORARY TRAFFIC SIGNALS ACCORDING TO STAGE 2 MAINTENANCE OF TRAFFIC DETAILS AND STANDARD 701321.
2. REMOVE THE SOUTH SIDE EXISTING BRIDGE, APPROACH, ABUTMENT, AND PIERS.
3. CONSTRUCT THE SOUTH SIDE OF BRIDGE INCLUDING PROPOSED RIP-RAP AND EARTHWORK.
4. REMOVE EXISTING HMA SURFACE ON THE EASTBOUND LANE.
5. INSTALL PROPOSED HMA SHOULDERS AND HMA LEVELING BINDER ON THE EASTBOUND LANE.
6. INSTALL THE PROPOSED GUARDRAIL ON THE NORTH SIDE.
7. COMPLETE CLOSURE POUR ON BRIDGE.

STAGE 3 NOTES:

1. REMOVE TRAFFIC CONTROL AND TEMPORARY TRAFFIC SIGNALS FROM STAGE III MAINTENANCE OF TRAFFIC DETAILS AND STANDARD 701321.
2. INSTALL PROPOSED HMA SURFACE COURSE.
3. INSTALL PERMANENT PAVEMENT MARKINGS.

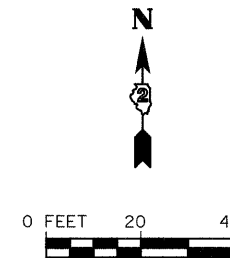

FILE NAME = S:\JOL\6300-6399\6346\027\MicroStation\sho\stg2\stage2-3.dgn



USER NAME = raymondk	DESIGNED -	REVISED -
PLOT SCALE = 20.0000 ' / IN.	DRAWN -	REVISED -
PLOT DATE = 7/21/2011	CHECKED -	REVISED -
	DATE -	REVISED -

STATE OF ILLINOIS
DEPARTMENT OF TRANSPORTATION



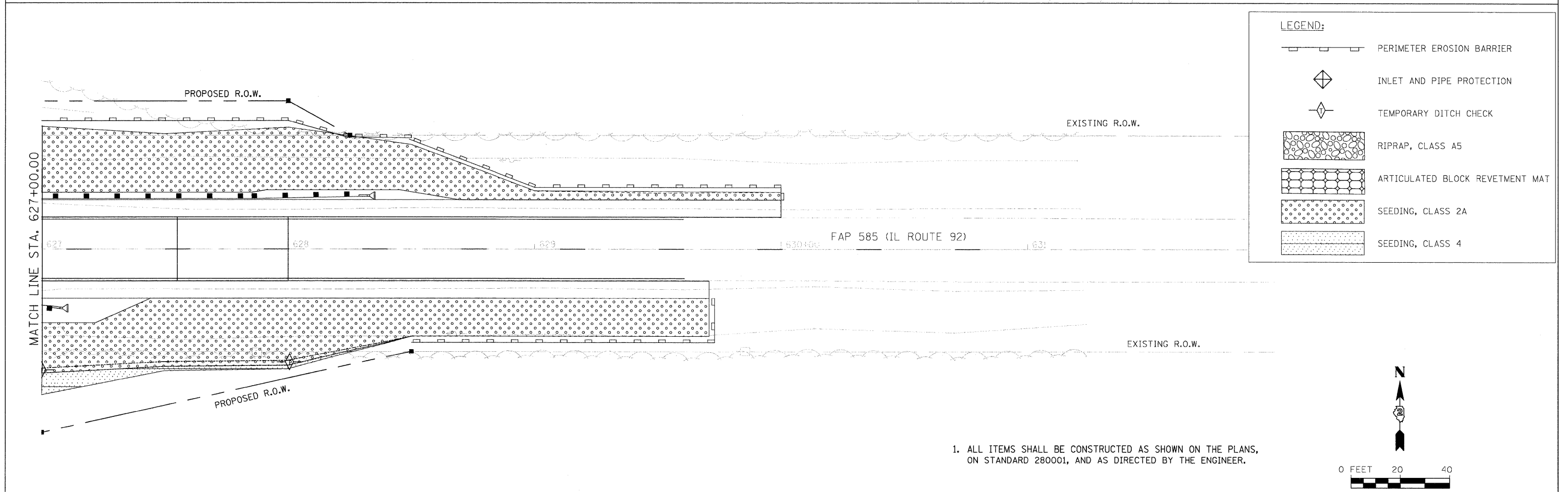
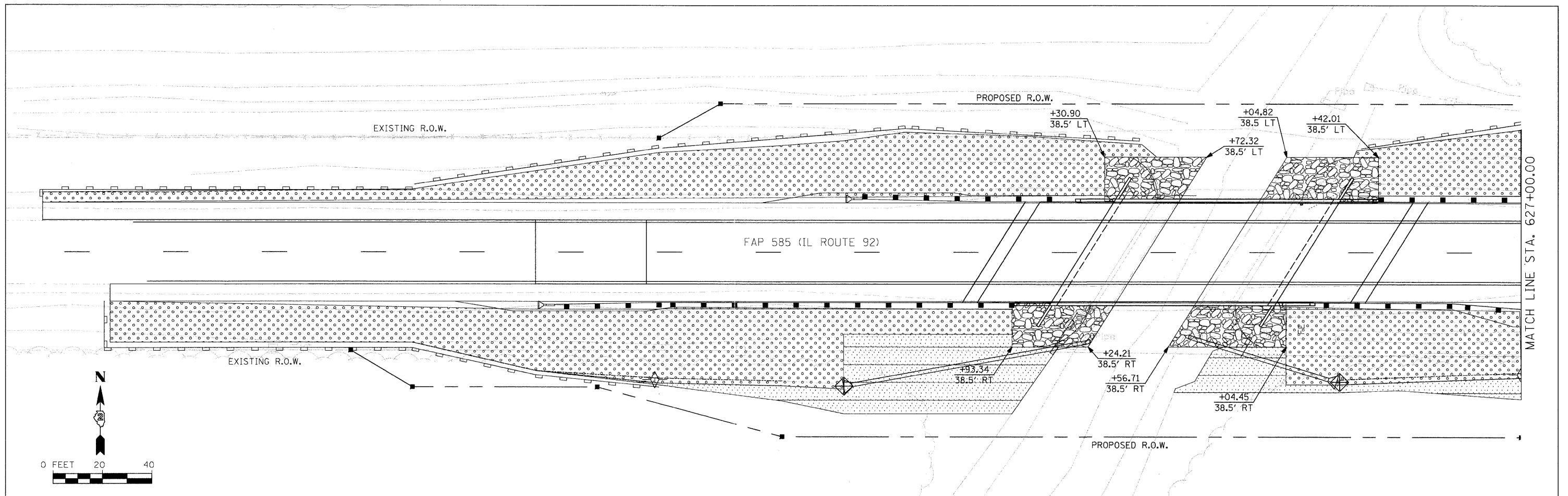

SUGGESTED MAINTENANCE OF TRAFFIC

SCALE: AS SHOWN SHEET NO. OF SHEETS STA. 628+00 TO STA. 634+00

F.A.P. RTE.	SECTION	COUNTY	TOTAL SHEETS	SHEET NO.
585	128 BR	HENRY	106	35
CONTRACT NO. 64C20				
FED. ROAD DIST. NO. 2 ILLINOIS FED. AID PROJECT				

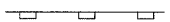

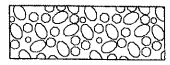
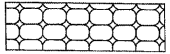
LEGEND:

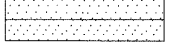
-  PERIMETER EROSION BARRIER
-  INLET AND PIPE PROTECTION
-  TEMPORARY DITCH CHECK
-  RIPRAP, CLASS A5
-  ARTICULATED BLOCK REVETMENT MAT
-  SEEDING, CLASS 2A
-  SEEDING, CLASS 4

1. ALL ITEMS SHALL BE CONSTRUCTED AS SHOWN ON THE PLANS, ON STANDARD 280001, AND AS DIRECTED BY THE ENGINEER.

1170 SOUTH HOUBOLT ROAD
JOLIET, ILLINOIS 60431
(815) 744-4200



FILE NAME =	USER NAME = brianf	DESIGNED -	REVISED -
st\joi\6300-6399\6346\027\mcoros\sh\st	terason1.dgn	DRAWN -	REVISED -
	PLOT SCALE = 20,000' / IN.	CHECKED -	REVISED -
	PLOT DATE = 7/19/2011	DATE -	REVISED -





**STATE OF ILLINOIS
DEPARTMENT OF TRANSPORTATION**

EROSION CONTROL

SCALE:	SHEET NO.	OF	SHEETS	STA.	TO STA.
--------	-----------	----	--------	------	---------

F.A.P. RTE.	SECTION	COUNTY	TOTAL SHEETS	SHEET NO.
585	128 BR	HENRY	106	36
CONTRACT NO. 64C20				
FED. ROAD DIST. NO. 2 ILLINOIS FED. AID PROJECT				

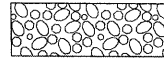
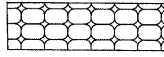
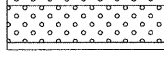
LEGEND:

-  PERIMETER EROSION BARRIER
-  INLET AND PIPE PROTECTION
-  TEMPORARY DITCH CHECK
-  RIPRAP, CLASS A5
-  ARTICULATED BLOCK REVETMENT MAT
-  SEEDING, CLASS 2A
-  SEEDING, CLASS 4

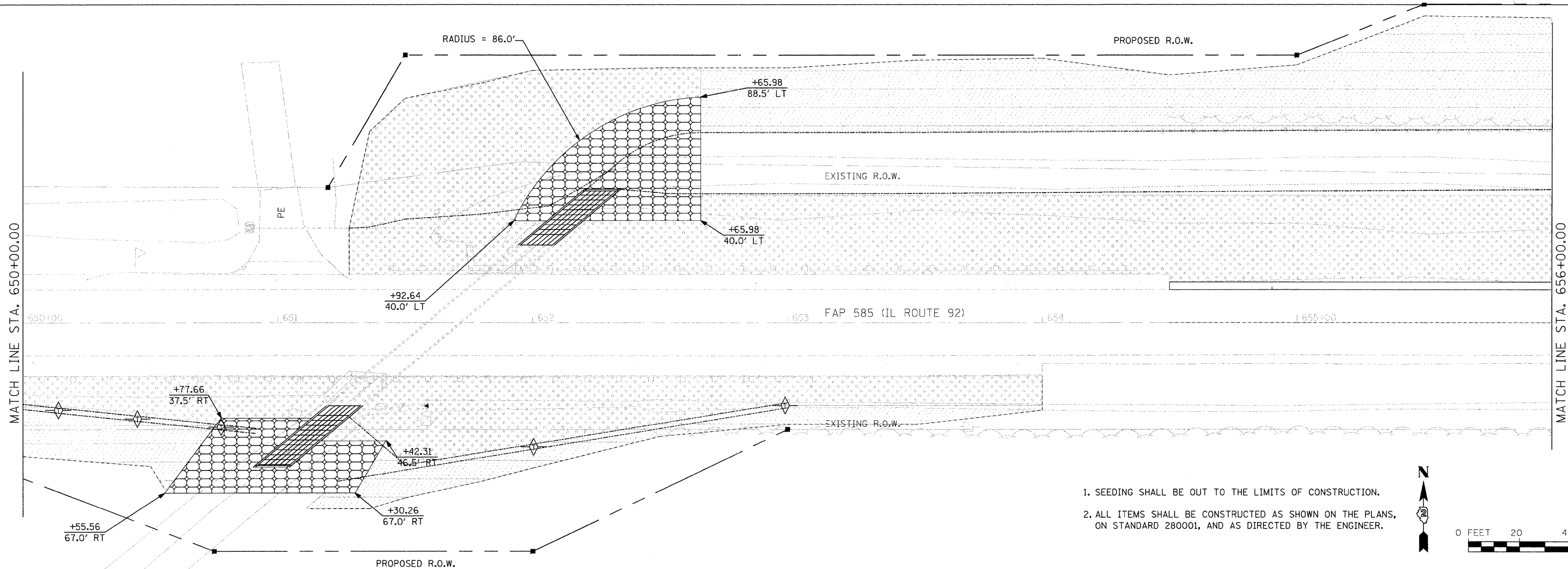
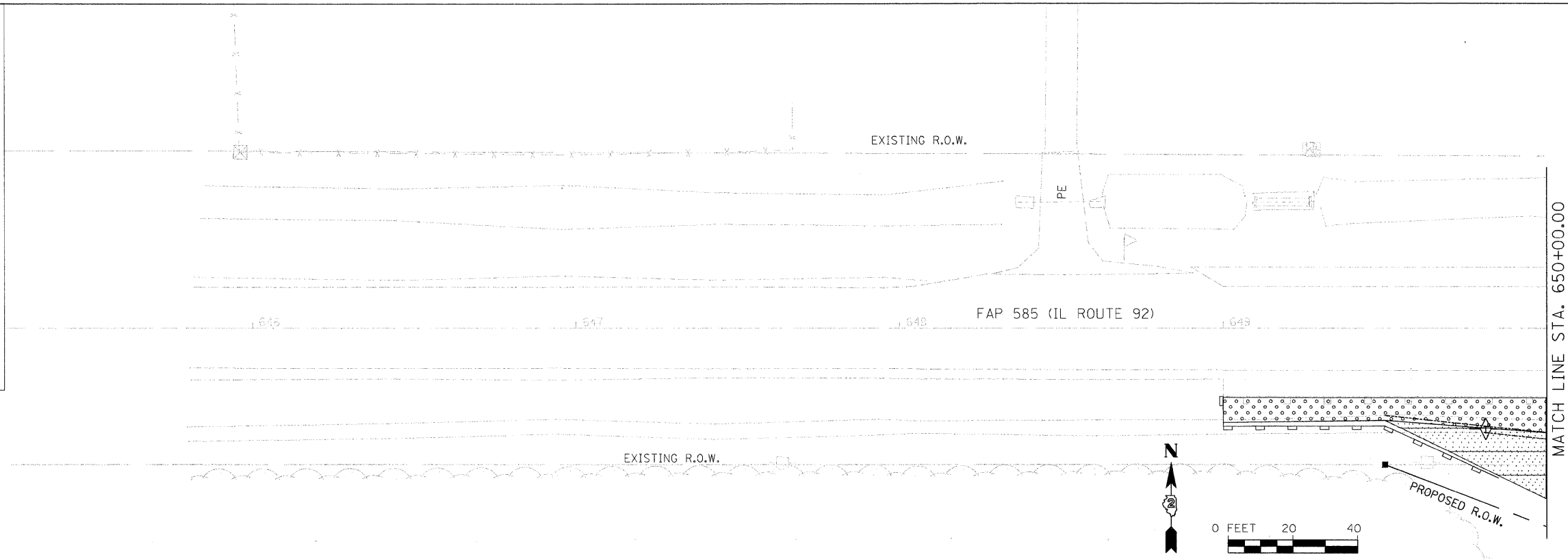

1. SEEDING SHALL BE OUT TO THE LIMITS OF CONSTRUCTION.
2. ALL ITEMS SHALL BE CONSTRUCTED AS SHOWN ON THE PLANS, ON STANDARD 280001, AND AS DIRECTED BY THE ENGINEER.

1170 SOUTH HOUBALT ROAD
 JOLIET, ILLINOIS 60431
 (815) 744-4200
RA
 REGISTERED PROFESSIONAL ENGINEER

FILE NAME =	USER NAME = brianf	DESIGNED -	REVISED -
st\joi\6300--6399\6346\027\micros\sh\sh\ter-erosion3.dgn		DRAWN -	REVISED -
		CHECKED -	REVISED -
		DATE -	REVISED -

**STATE OF ILLINOIS
DEPARTMENT OF TRANSPORTATION**

EROSION CONTROL				
SCALE:	SHEET NO.	OF SHEETS	STA.	TO STA.

F.A.P. RTE. 585	SECTION 128 BR	COUNTY HENRY	TOTAL SHEETS 106	SHEET NO. 37
FED. ROAD DIST. NO. 2 ILLINOIS FED. AID PROJECT				

MATCH LINE STA. 650+00.00

MATCH LINE STA. 656+00.00

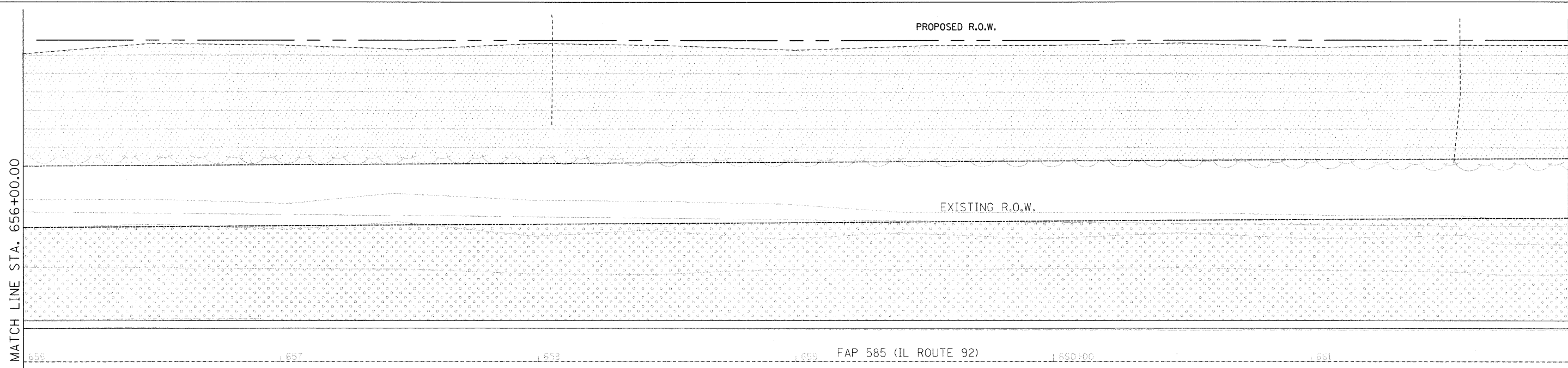

LEGEND:

	PERIMETER EROSION BARRIER		RIPRAP, CLASS A5		SEEDING, CLASS 4
	INLET AND PIPE PROTECTION		ARTICULATED BLOCK REVETMENT MAT		TURF REINFORCEMENT MAT
	TEMPORARY DITCH CHECK		SEEDING, CLASS 2A		

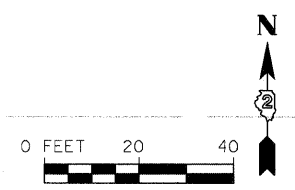
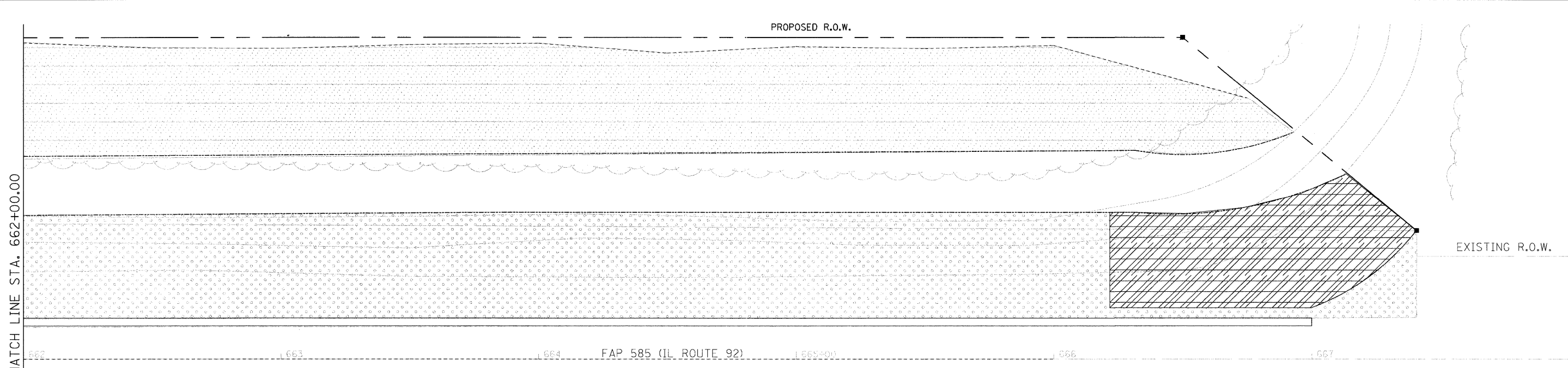
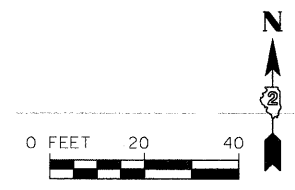

1. ALL ITEMS SHALL BE CONSTRUCTED AS SHOWN ON THE PLANS, ON STANDARD 280001, AND AS DIRECTED BY THE ENGINEER.
2. SEEDING SHALL BE OUT TO THE LIMITS OF CONSTRUCTION.

1170 SOUTH HOUBOLT ROAD
 JOLIET, ILLINOIS 60431
 (815) 744-4200
RR
 ENGINEERS

FILE NAME =	USER NAME = brianf	DESIGNED -	REVISED -	STATE OF ILLINOIS DEPARTMENT OF TRANSPORTATION	EROSION CONTROL			F.A.P. RTE. 585	SECTION 128 BR	COUNTY HENRY	TOTAL SHEETS 106	SHEET NO. 38
st\joi\6300-6399\6346\027\micos\sh\st	terrosion4.dgn	DRAWN -	REVISED -		SCALE:	SHEET NO.	OF SHEETS	STA.	TO STA.	CONTRACT NO. 64C20		
	PLOT SCALE = 20,0000' / IN.	CHECKED -	REVISED -		FED. ROAD DIST. NO. 2 ILLINOIS FED. AID PROJECT							
	PLOT DATE = 7/19/2011	DATE -	REVISED -									

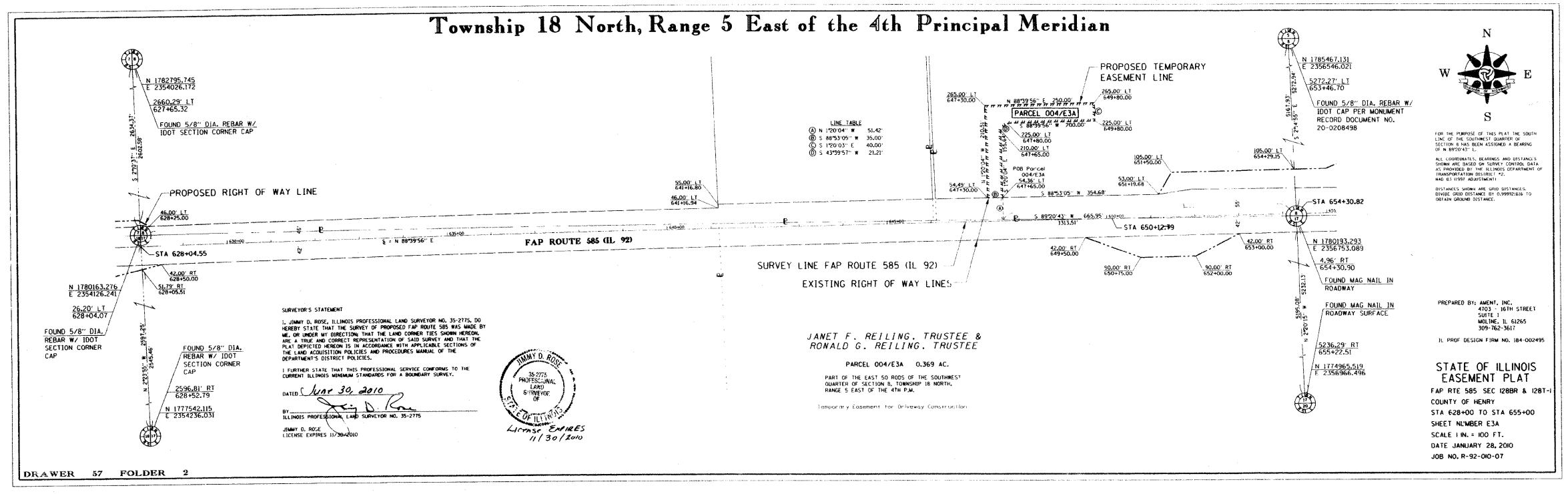
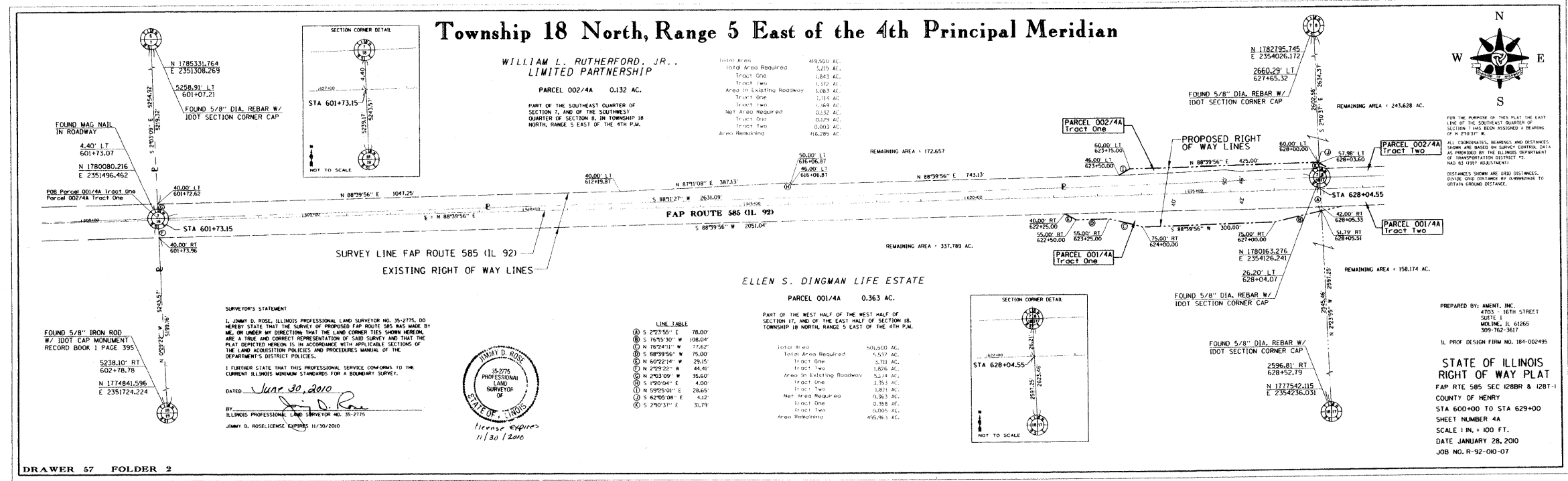

FILE NAME = F:\whs-5002.dgn



1170 SOUTH HOUBOLT ROAD
 JULIET, ILLINOIS 60431
 (815) 744-4200

USER NAME = grantpm	DESIGNED -	REVISED -
PLOT SCALE = 20.0000' / 1"	DRAWN -	REVISED -
PLOT DATE = Wed Jul 27 09:49:39 2011	CHECKED -	REVISED -
	DATE -	REVISED -

**STATE OF ILLINOIS
 DEPARTMENT OF TRANSPORTATION**

RIGHT OF WAY PLAT

SCALE: AS SHOWN	SHEET NO.	OF	SHEETS	STA.	TO STA.
-----------------	-----------	----	--------	------	---------

F.A.P. RTE.	SECTION	COUNTY	TOTAL SHEETS	SHEET NO.
585	128 BR	HENRY	106	39
CONTRACT NO. 64C20				
FED. ROAD DIST. NO. 2 ILLINOIS FED. AID PROJECT				

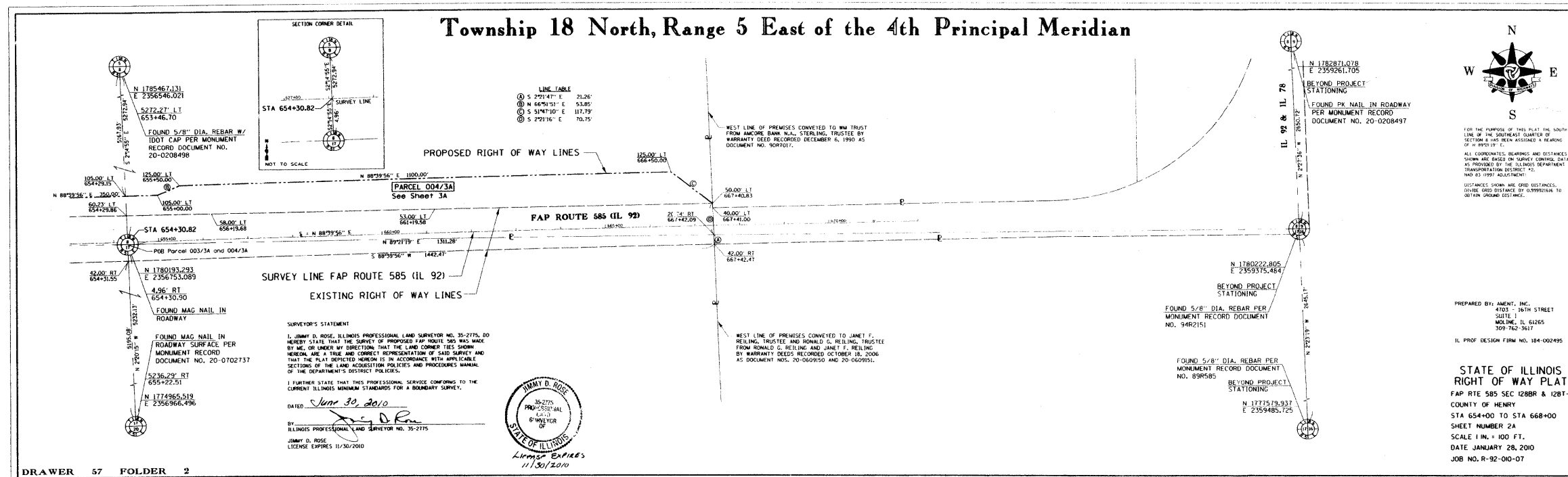
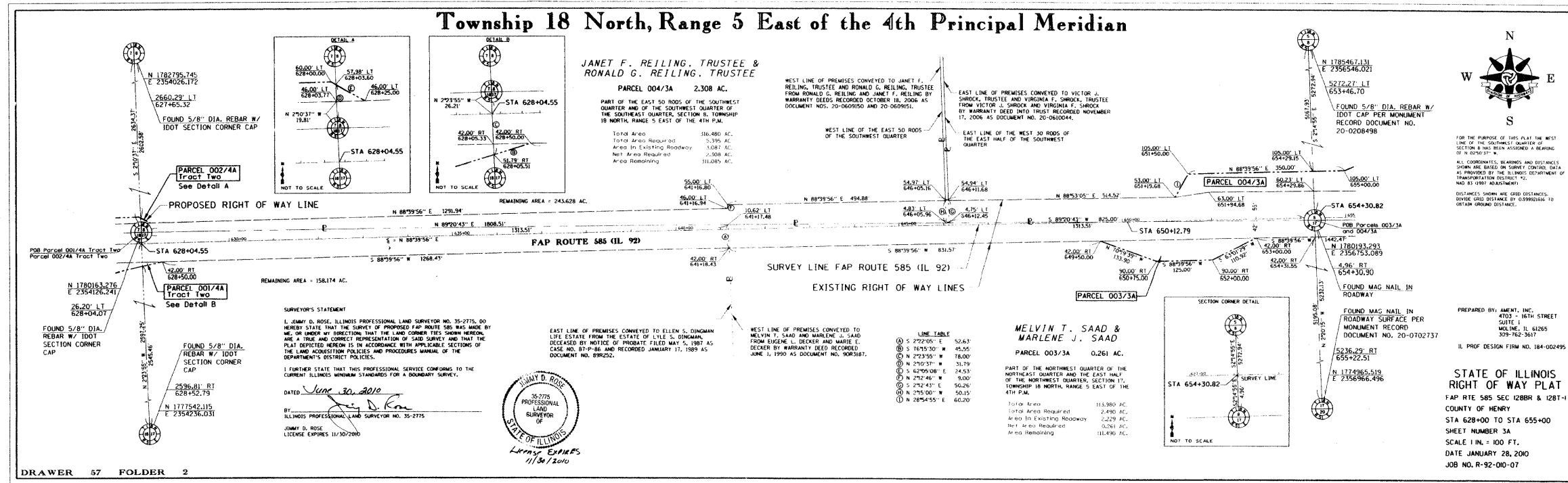

FILE NAME = F:\1175-S022.dwg

STRAND ASSOCIATES, INC.
ENGINEERS
1170 SOUTH HOUBOLT ROAD
JOLIET, ILLINOIS 60431
(815) 744-4200

USER NAME =	grantpm
DESIGNED -	
DRAWN -	
CHECKED -	
DATE	

DESIGNED -	
DRAWN -	
CHECKED -	
DATE	

STATE OF ILLINOIS
DEPARTMENT OF TRANSPORTATION

SCALE: AS SHOWN	SHEET NO.	OF	SHEETS	STA.	TO STA.

F.A.P. RTE.	SECTION	COUNTY	TOTAL SHEETS	SHEET NO.
585	128 BR	HENRY	106	40
CONTRACT NO. 64C20				
FED. ROAD DIST. NO. 2 ILLINOIS FED. AID PROJECT				

Bench Mark: Chiseled square on Concrete Headwall north of Structure 037-0069 El. 606.72

Existing Structure: S.N. 037-0069 built in 1929 as SBI Route 82, Section 128B. In 1949 Structure was widened as SBI Route 82, Section 128B-Y. The structure consists of single span reinforced concrete deck overlayed with a bituminous wearing surface on reinforced concrete tee beams supported by closed abutments with untreated timber piles. 58'-7 1/2" back to back of abutments. 43'-4" out to out deck. Existing structures to be removed and replaced. Traffic shall be maintained using stage construction.

STATE OF ILLINOIS
DEPARTMENT OF TRANSPORTATION

GENERAL NOTES

Fasteners shall be AASHTO M164 Type 1, mechanically galvanized bolts (in painted areas and M164 Type 3 in unpainted areas). Bolts 3/4" φ, holes 15/16" φ, unless otherwise noted.
Calculated weight of Structural Steel = 111,700 Pounds.
All structural steel shall be AASHTO M 270 Grade 50W. All structural steel shall be cleaned as specified in the Special Provision for "Surface Preparation and Painting Requirements for Weathering Steel".
No field welding is permitted except as specified in the contract documents.
Reinforcement bars shall conform to the requirements of ASTM A 706 Gr 60. See Special Provisions. Reinforcement bars designated (E) shall be epoxy coated.
Structural steel shall only be painted for a distance equal to the depth of embedment into the concrete cap plus 3 inches. Painted areas shall be primed in the shop with a Department approved zinc rich primer. Field painting will not be required.
Layout of slope protection system may be varied to suit ground conditions in the field as directed by the Engineer.
The embankment configuration shown shall be the minimum that must be placed and compacted prior to construction of the abutments.
Slip forming of parapet is not allowed.

No salvage

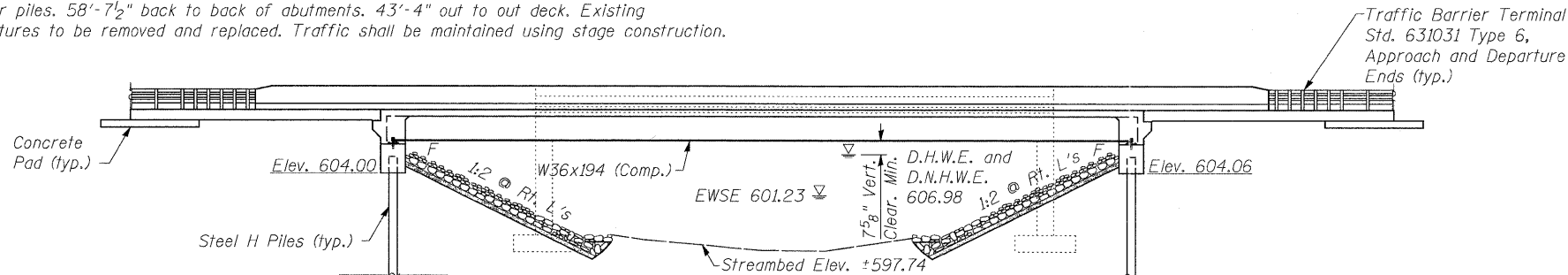

ELEVATION

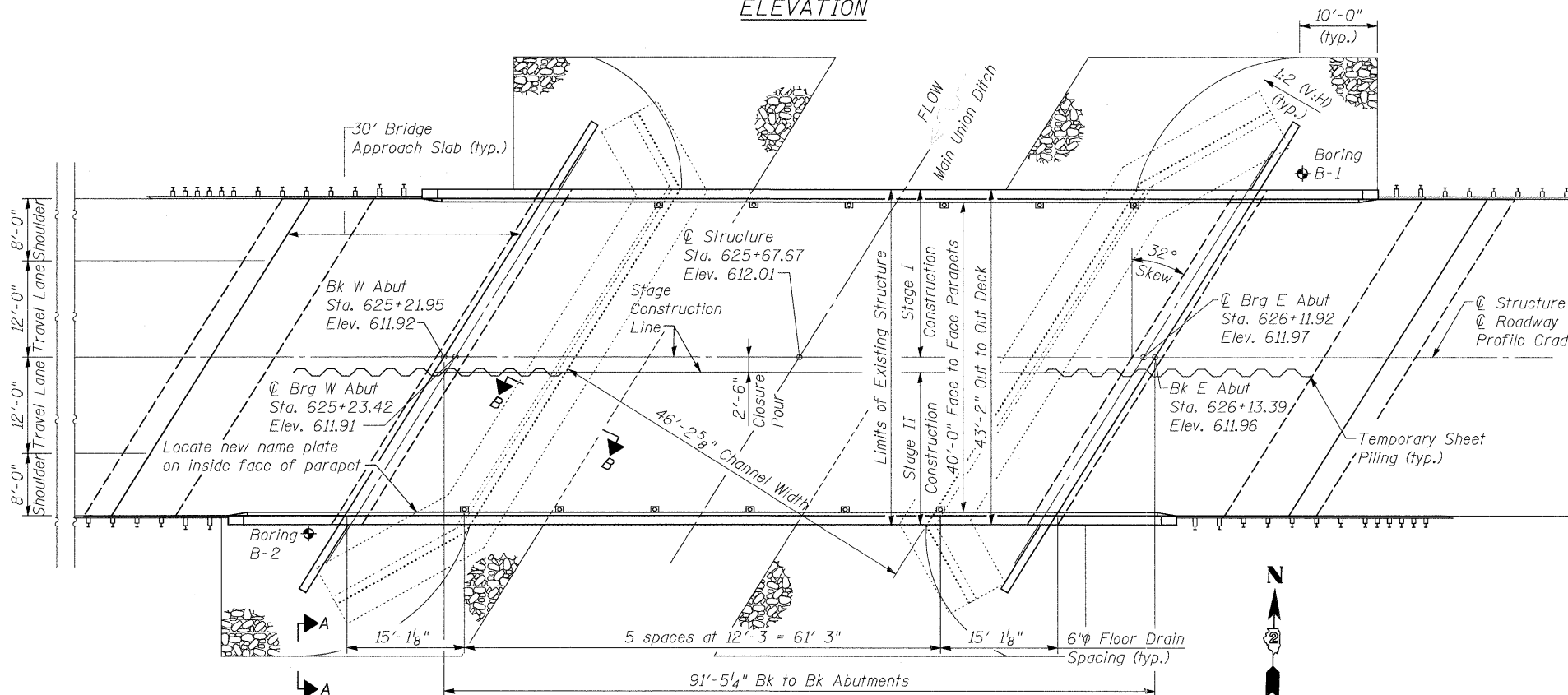

PLAN

INDEX OF SHEETS

- 1 General Plan and Elevation
- 2 Suggested Stage Construction/General Details
- 3 Temporary Concrete Barrier
- 4-6 Top of Slab Elevations Superstructure
- 7 Superstructure
- 8 Superstructure Details
- 9 Integral Abutment Diaphragm Details
- 10-11 Bridge Approach Slab Details
- 12 Steel Framing Plan and Beam Details
- 13 Moment Table
- 14 West Abutment Details
- 15 East Abutment Details
- 16 HP Pile Details
- 17 Bar Splicer Assembly and Mechanical Splicer Details
- 18-20 Soil Boring Log

STATION 625+67.67
BUILT 201_ BY
STATE OF ILLINOIS
F.A.P. RTE. 585 SEC. 128 BR
LOADING HL-93
STRUCTURE NO. 037-0174

NAME PLATE
See Std. 515001

LOADING HL-93
Allow 50#/sq. ft. for future wearing surface.

DESIGN SPECIFICATIONS
2007 AASHTO LRFD Bridge Design Specifications
with 2008 and 2009 Interims

DESIGN STRESSES

FIELD UNITS

f'c = 3,500 psi
fy = 60,000 psi (Reinforcement)
fy = 50,000 psi (M270 Grade 50W)

SEISMIC DATA

Seismic Performance Zone (SPZ) = 1
Design Spectral Acceleration at 1.0 sec (SD1) = 0.089g
Design Spectral Acceleration at 0.2 sec (SD5) = 0.140g
Soil Site Class = D

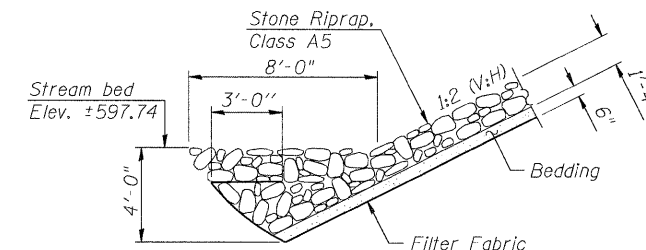

SECTION B-B

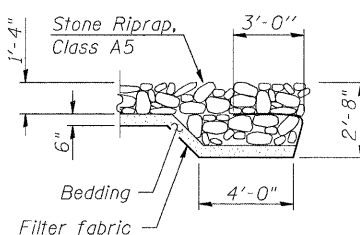

SECTION A-A

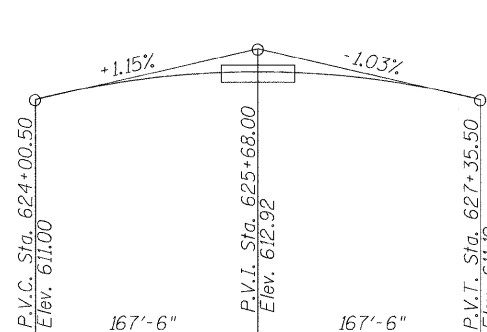

PROFILE GRADE
(F.A.P. 585 along C of Roadway)

WATERWAY INFORMATION

Drainage Area = 12.02 mi.² Low Grade Elev. 611.98 @ Sta. 626+08

Flood	Freq. Yr.	Q C.F.S.	Opening Sq. Ft.		Nat. H.W.E.	Head - Ft.		Headwater El.	
			Exist.	Prop.		Exist.	Prop.	Exist.	Prop.
Design	10	427	302	330	605.56	0.01	0.00	605.57	605.56
Base	50	598	346	431	606.98	0.02	0.00	607.00	606.98
Overtopping	100	663	391	466	607.22	0.00	0.00	607.22	607.22
Max. Calc.	500	810	400	478	607.37	0.02	0.02	607.39	607.39

DESIGN SCOUR ELEVATION TABLE

Design Scour Elevation (ft.)	W. Abut.	E. Abut.
	604.04	604.09

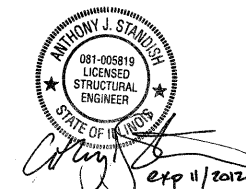

APPROVED
FOR STRUCTURAL ADEQUACY ONLY
ENGINEER OF BRIDGES AND STRUCTURES

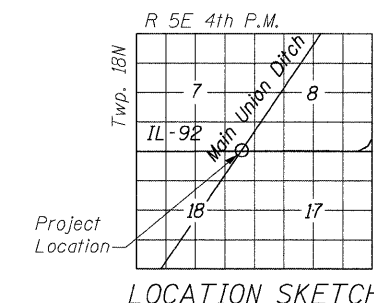

LOCATION SKETCH

GENERAL PLAN AND ELEVATION
IL-92 OVER MAIN UNION DITCH
F.A.P. RTE 585 - SEC. 128 BR
HENRY COUNTY
STATION 625+67.67
STRUCTURE NO. 037-0174

FILE NAME = S:\JLD\63300-63999\6346\027\Misc\Final Plans\Structural\0370174-64C20-001-DPE.dgn



USER NAME = brianf	DESIGNED MJD	REVISED -
PLOT SCALE =	CHECKED AJS	REVISED -
PLOT DATE = 8/11/2011	DRAWN B/JF	REVISED -
	CHECKED RRD	REVISED -

STATE OF ILLINOIS
DEPARTMENT OF TRANSPORTATION

GENERAL PLAN AND ELEVATION
STRUCTURE NO. 037-0174

SHEET NO. 1 OF 20 SHEETS

F.A.P. RTE.	SECTION	COUNTY	TOTAL SHEETS	SHEET NO.
585	128 BR	HENRY	106	45

CONTRACT NO. 64C20
ILLINOIS FED. AID PROJECT

STATE OF ILLINOIS
DEPARTMENT OF TRANSPORTATION

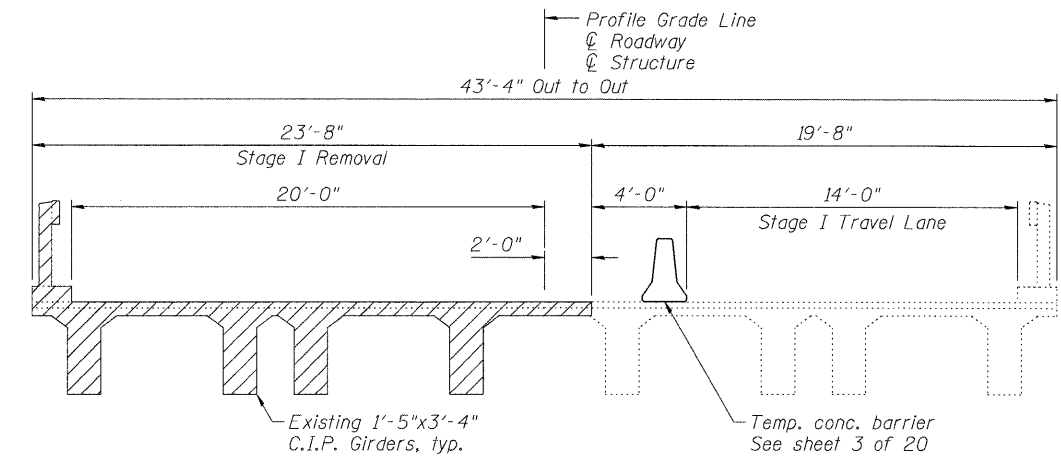

STAGE I REMOVAL

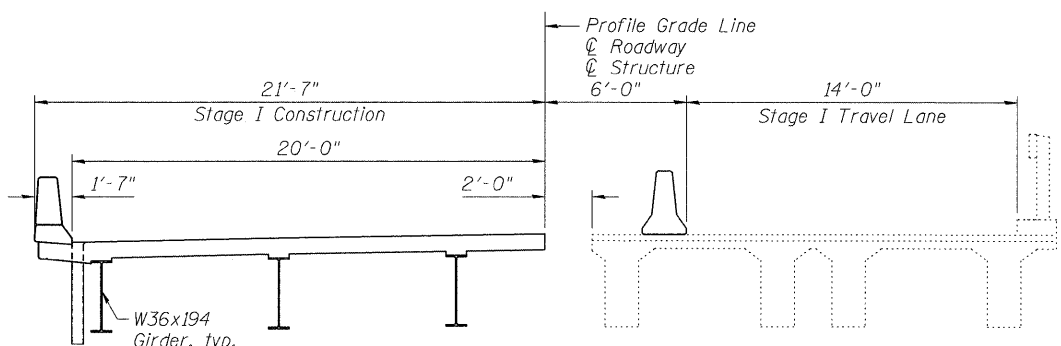

STAGE I CONSTRUCTION

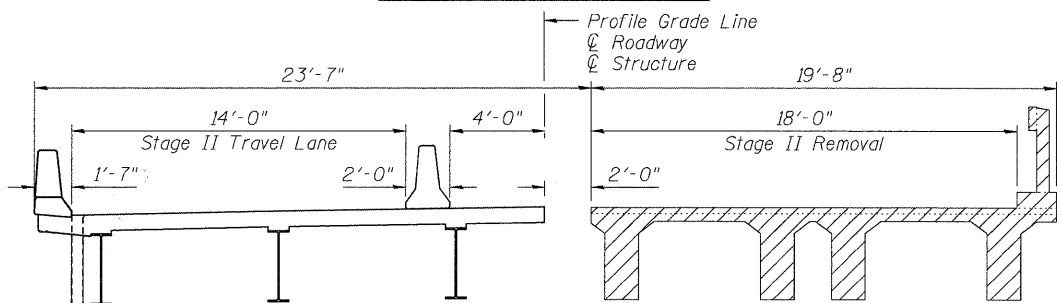

STAGE II REMOVAL

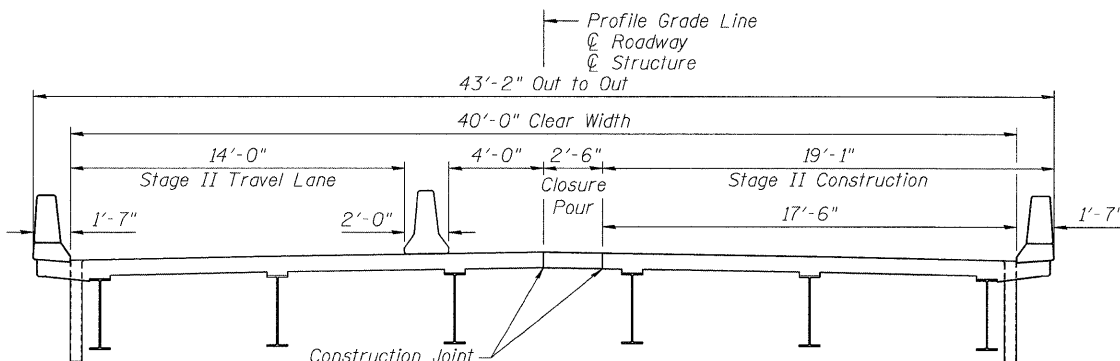

STAGE II CONSTRUCTION & CLOSURE POUR

LEGEND

- Removal of Existing Structures
- Proposed Concrete

Note:
All cross sections are looking East.
Abutment and Approach Slab will not require a Closure Pour.

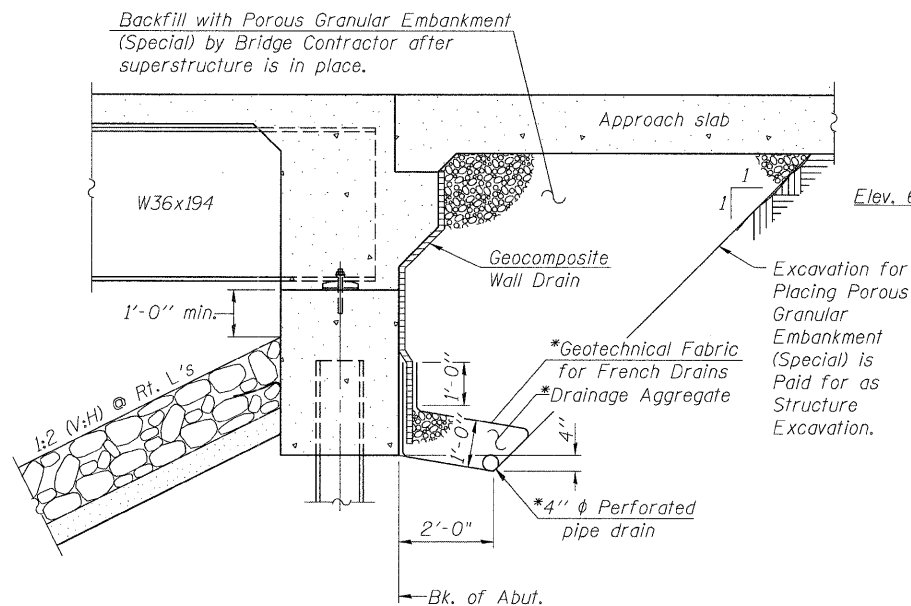

SECTION THRU INTEGRAL ABUTMENT

(Horiz. dim. @ Rt. L's)

*Included in the cost of Pipe Underdrains for Structures, 4".

Note:
All drainage system components shall extend to 2'-0" from the end of each wingwall except an outlet pipe shall extend until intersecting with the side slopes. The pipes shall drain into concrete headwalls. (See Article 601.05 of the Standard Specifications and Highway Standard 601101).

TOTAL BILL OF MATERIAL

ITEM	UNIT	SUPER	SUB	TOTAL
Stone Riprap, Class A5	Sq Yd		608	608
Filter Fabric	Sq Yd		608	608
Removal Of Existing Structures	Each		1	1
Structure Excavation	Cu Yd		426	426
Floor Drains	Each	12		12
Concrete Structures	Cu Yd		79	79
Concrete Superstructure	Cu Yd	299		299
Bridge Deck Grooving	Sq Yd	643		643
Concrete Encasement	Cu Yd		6	6
Protective Coat	Sq Yd	810		810
Furnishing And Erecting Structural Steel	L Sum	1		1
Stud Shear Connectors	Each	3,204		3,204
Reinforcement Bars, Epoxy Coated	Pound	63,760	14,040	77,800
Bar Splicers	Each	984	20	1,004
Furnishing Steel Piles HP12x53	Foot		1,316	1,316
Driving Piles	Foot		1,316	1,316
Test Pile Steel HP12x53	Each		2	2
Name Plates	Each	1		1
Anchor Bolts, 1"	Each		24	24
Geocomposite Wall Drain	Sq Yd		100	100
Pipe Underdrains For Structures 4"	Foot		167	167
Porous Granular Embankment, Special	Cu Yd		199	199
Temporary Sheet Piling	Sq Ft		1,370	1,370

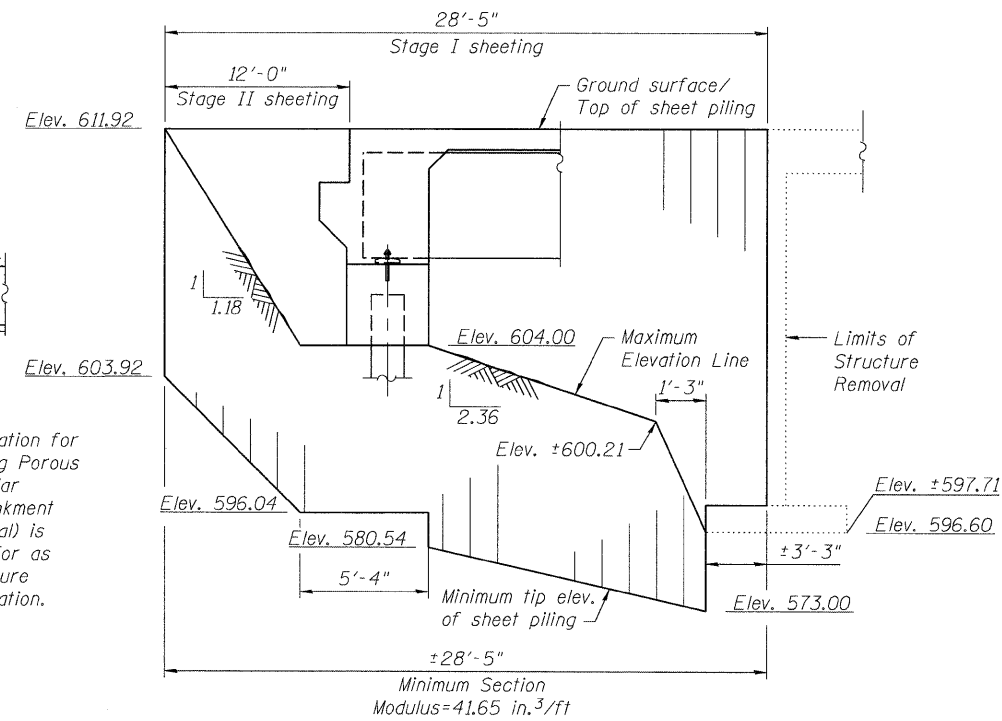

WEST ABUTMENT
TEMPORARY SHEET PILING

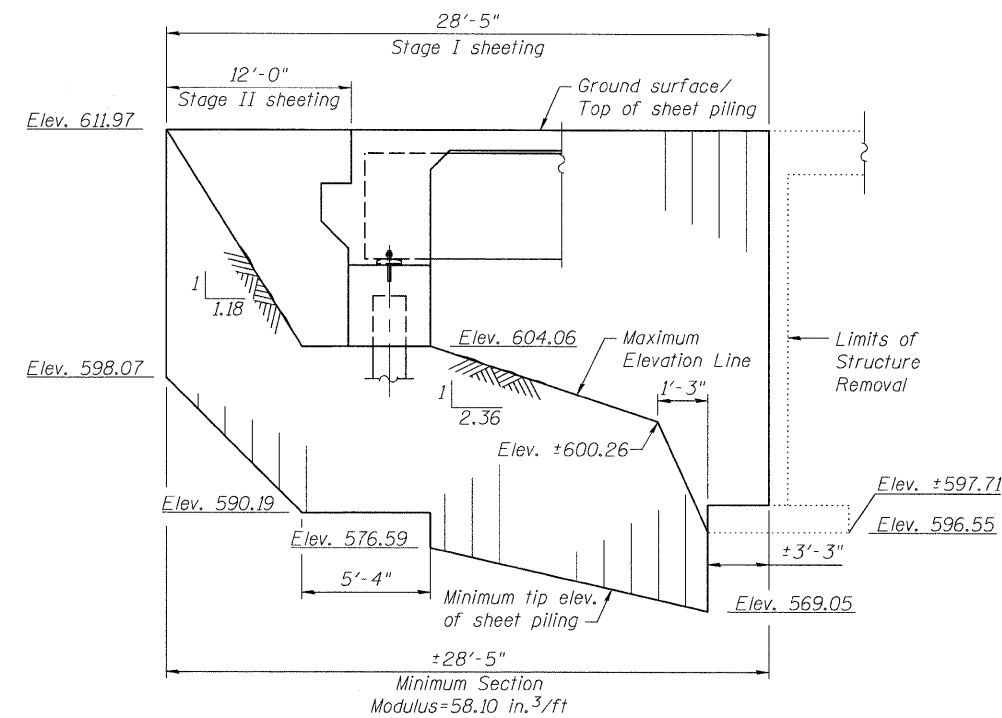

EAST ABUTMENT
TEMPORARY SHEET PILING

Note:
The Contractor shall connect the first sheet to the existing abutment wall to ensure stability of sheets driven to the top of the existing footing. This connection shall be reviewed and accepted by the Engineer and included in the cost for Temporary Sheet Piling.
If the Contractor chooses to alter the temporary cantilevered sheet piling design requirements shown on the plans, a design submittal including plan details and calculations will be required for review and acceptance by the Engineer.

FILE NAME = s:\jpl\6300-6395\6346\027\micro\final plans\structure\0370174-64C20-002-STAGE.dgn

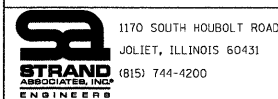

1170 SOUTH HOUBOLT ROAD JOLIET, ILLINOIS 60431 (815) 744-4200	USER NAME = brianf	DESIGNED MJD	REVISED -
PLOT SCALE =	DRAWN B/JF	CHECKED AJS	REVISED -
PLOT DATE = 7/19/2011	CHECKED R/RD	DRAWN B/JF	REVISED -
		CHECKED R/RD	REVISED -

STATE OF ILLINOIS
DEPARTMENT OF TRANSPORTATION

SUGGESTED STAGE CONSTRUCTION / GENERAL DETAILS
STRUCTURE NO. 037-0174

SHEET NO. 2 OF 20 SHEETS

F.A.P. RTE.	SECTION	COUNTY	TOTAL SHEETS	SHEET NO.
585	128 BR	HENRY	106	46
CONTRACT NO. 64C20			ILLINOIS FED. AID PROJECT	

When "A" is 3'-6" or less, the temporary concrete barrier shall be anchored to the new slab according to Detail I or Detail II. No anchorage is required when "A" is greater than 3'-6".

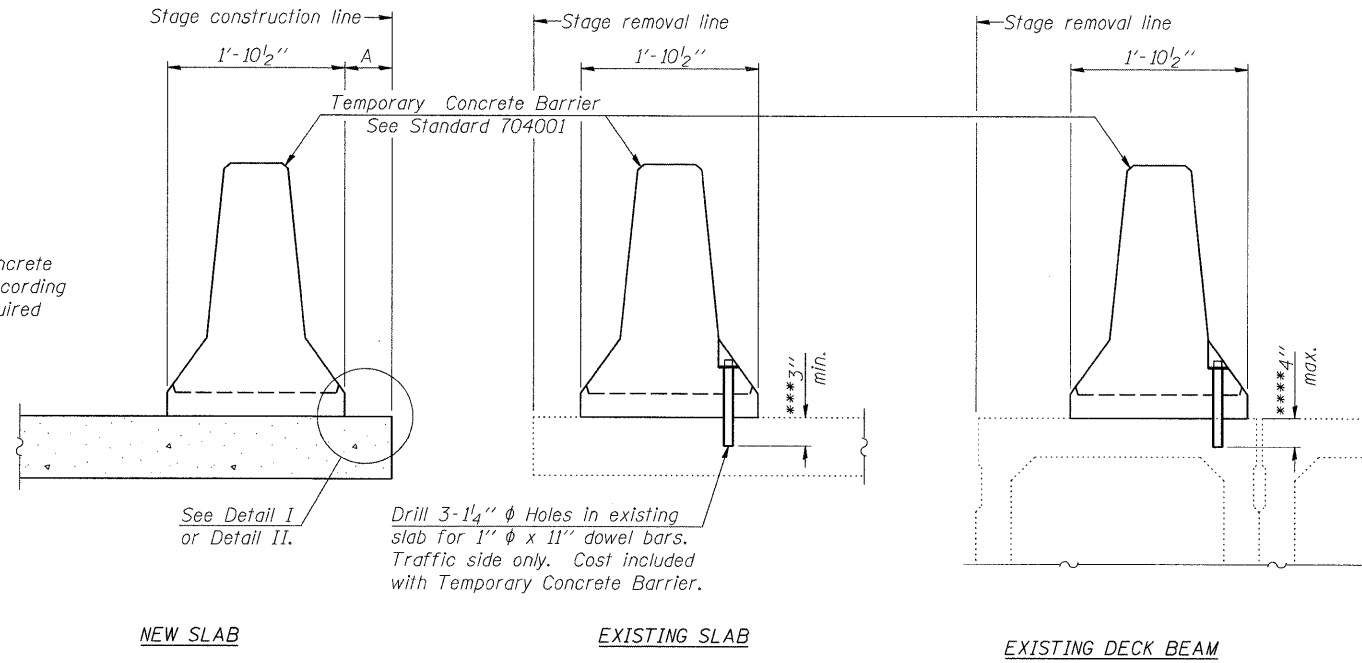

SECTIONS THRU SLAB OR DECK BEAM

NOTES

Detail I - With Bar Splicer or Couplers:
Connect one (1) 1" x 7" x "W" steel PL to the top layer of couplers with 2-5/8" ϕ bolts screwed to coupler at approximate ϕ of each barrier panel.

Detail II - With Extended Reinforcement Bars:
Connect one (1) 1" x 7" x "W" steel PL to the concrete slab or concrete wearing surface with 2-5/8" ϕ Expansion Anchors or cast in place inserts spaced between the top layer of reinforcement at approximate ϕ of each barrier panel.

Cost of anchorage is included with Temporary Concrete Barrier. The 1" x 7" x "W" plate shall not be removed until stage II construction forms and all reinforcement bars are in place and the concrete is ready to be placed.

*** Dimension shown is minimum required embedment into concrete. If hot-mix asphalt wearing surface is present, minimum embedment shall be in addition to wearing surface depth.

**** If existing deck beam is to remain in place after stage construction, embedment shall only be into wearing surface and not into existing deck beam concrete.

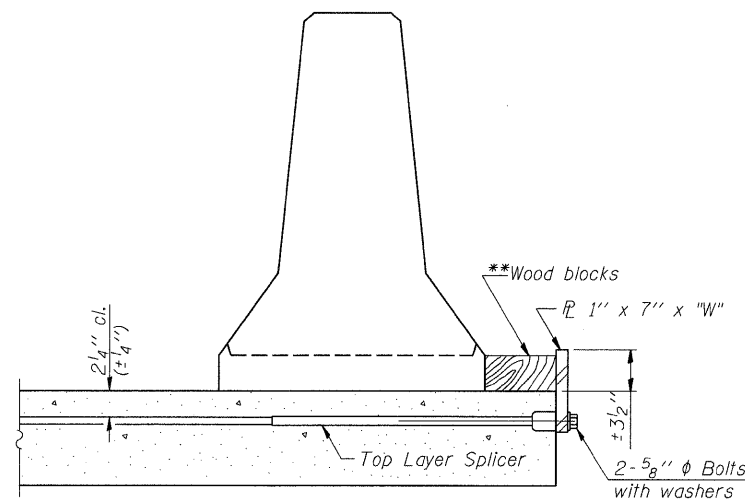

DETAIL I

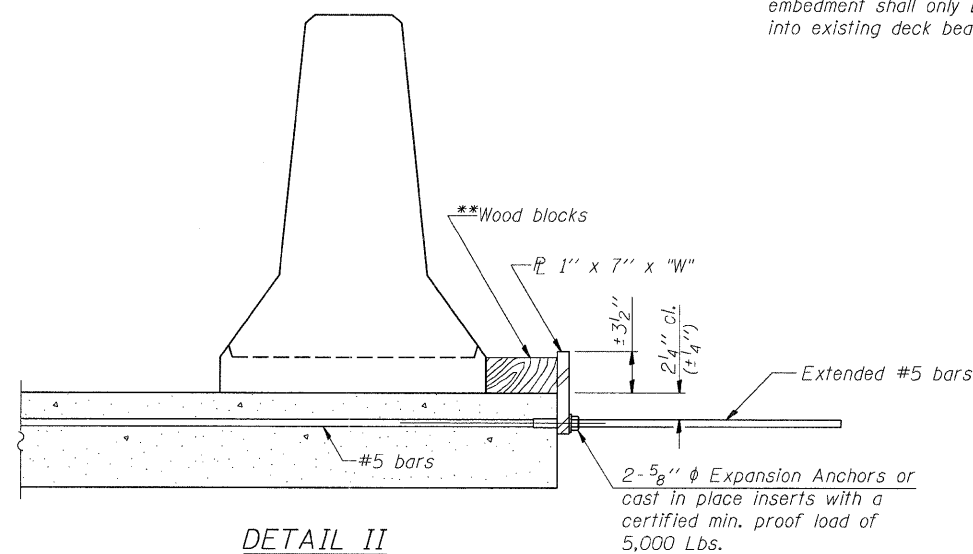

DETAIL II

** Wood blocks may be omitted when required to provide minimum stage traffic lane width. When the wood blocks are omitted, the concrete barrier shall be in direct contact with the steel retainer plate.

"W" = Top bars spacing + 4"

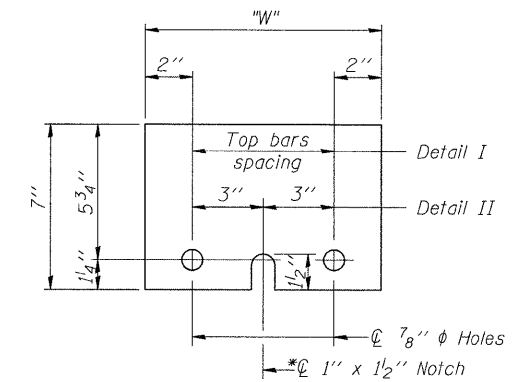

STEEL RETAINER PL 1" x 7" x "W"

* Required only with Detail II

FILE NAME = s:\p1\63800-6399\6345\027\microso\Inet.plans\structure\0370174-64C20-003-TCB.dgn

R-27

7-1-10

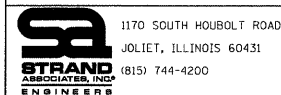

USER NAME = brianf	DESIGNED MJD	REVISED -
PLOT SCALE =	CHECKED AJS	REVISED -
PLOT DATE = 7/19/2011	DRAWN B/JF	REVISED -
	CHECKED RRD	REVISED -

STATE OF ILLINOIS
DEPARTMENT OF TRANSPORTATION

TEMPORARY CONCRETE BARRIER
STRUCTURE NO. 037-0174

SHEET NO. 3 OF 20 SHEETS

F.A.P. RTE.	SECTION	COUNTY	TOTAL SHEETS	SHEET NO.
585	128 BR	HENRY	106	47
				CONTRACT NO. 64C20
ILLINOIS FED. AID PROJECT				

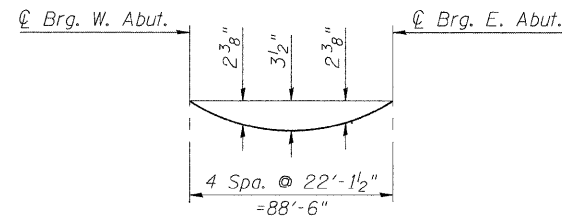

DEAD LOAD DEFLECTION DIAGRAM

(Includes weight of concrete only.)

Note:
The above deflections are not to be used in the field if the engineer is working from the grade elevations adjusted for dead load deflections as shown on sheet 5 of 20.

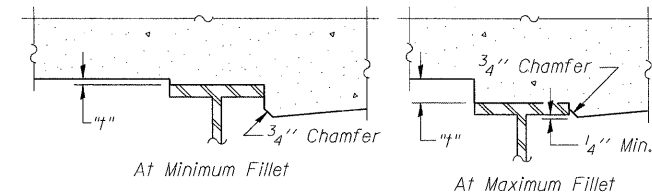

EXTERIOR BEAMS

To determine "f": After all structural steel has been erected, elevations of the top flanges of the beams shall be taken at intervals shown below. These elevations subtracted from the "Theoretical Grade Elevations Adjusted for Dead Load Deflection" shown below, minus slab thickness, equals the fillet heights "f" above top flange of beams.

See sheet 12 of 20 for interior fillet details.

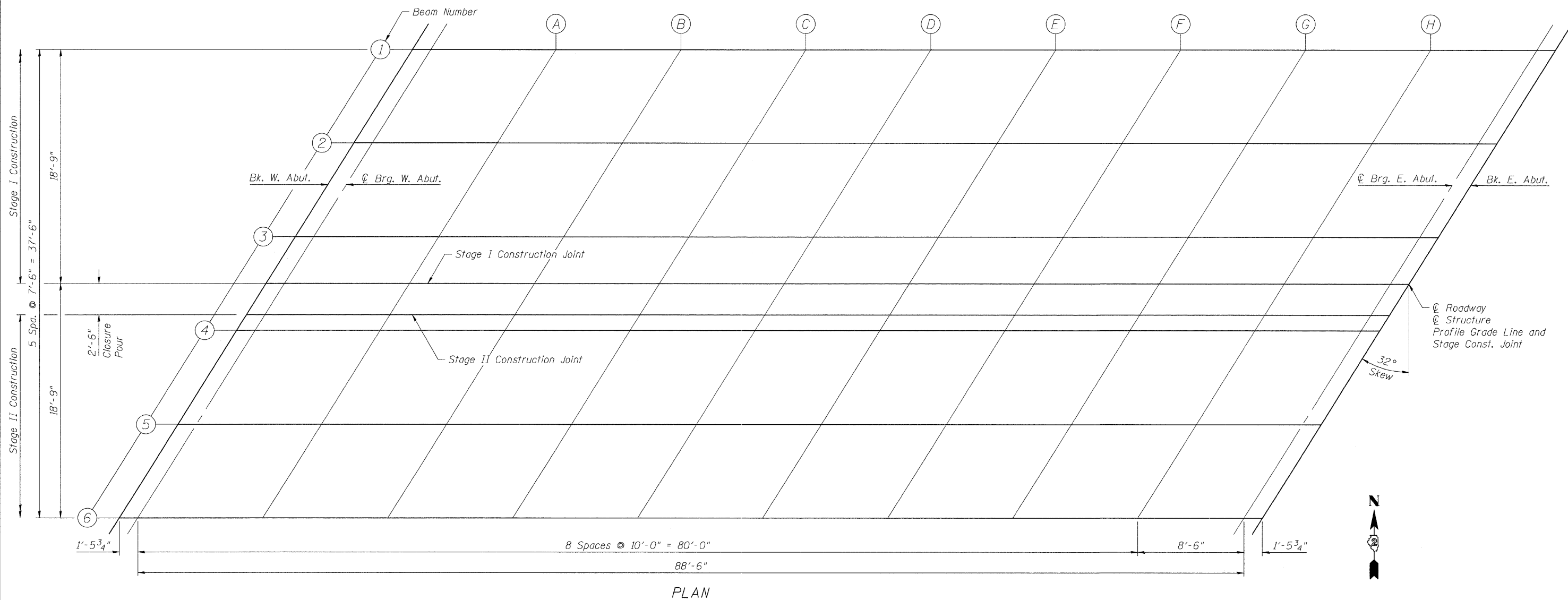

PLAN

FILE NAME = S:\JUL\63800-6395\6346\027\Work\Final Plans\Structural\0370174-64C20-004-TSE.dgn

	1170 SOUTH HOUBOLT ROAD JOLIET, ILLINOIS 60431 (815) 744-4200	USER NAME = brionf	DESIGNED <i>MJD</i>	REVISED -	STATE OF ILLINOIS DEPARTMENT OF TRANSPORTATION	TOP OF SLAB ELEVATIONS (1 OF 3) STRUCTURE NO. 037-0174	F.A.P. RTE. 585	SECTION 128 BR	COUNTY HENRY	TOTAL SHEETS 106	SHEET NO. 48
	PLOT SCALE =	DRAWN <i>BJF</i>	REVISED -	CONTRACT NO. 64C20							
	PLOT DATE = 8/11/2011	CHECKED <i>RRD</i>	REVISED -	ILLINOIS FED. AID PROJECT							
	SHEET NO. 4 OF 20 SHEETS										

BEAM 1

Table with 5 columns: Location, Station, Offset, Theoretical Grade Elevations, Theoretical Grade Elevations Adjusted for Dead Load Deflection. Rows include Back of W. Abut., CL Brq. W. Abut., A through H, CL Brq. E. Abut., and Back of E. Abut.

BEAM 5

Table with 5 columns: Location, Station, Offset, Theoretical Grade Elevations, Theoretical Grade Elevations Adjusted for Dead Load Deflection. Rows include Back of W. Abut., CL Brq. W. Abut., A through H, CL Brq. E. Abut., and Back of E. Abut.

BEAM 2

Table with 5 columns: Location, Station, Offset, Theoretical Grade Elevations, Theoretical Grade Elevations Adjusted for Dead Load Deflection. Rows include Back of W. Abut., CL Brq. W. Abut., A through H, CL Brq. E. Abut., and Back of E. Abut.

BEAM 6

Table with 5 columns: Location, Station, Offset, Theoretical Grade Elevations, Theoretical Grade Elevations Adjusted for Dead Load Deflection. Rows include Back of W. Abut., CL Brq. W. Abut., A through H, CL Brq. E. Abut., and Back of E. Abut.

BEAM 3

Table with 5 columns: Location, Station, Offset, Theoretical Grade Elevations, Theoretical Grade Elevations Adjusted for Dead Load Deflection. Rows include Back of W. Abut., CL Brq. W. Abut., A through H, CL Brq. E. Abut., and Back of E. Abut.

PGL/CL ROADWAY/STAGE I CONSTRUCTION LINE

Table with 5 columns: Location, Station, Offset, Theoretical Grade Elevations, Theoretical Grade Elevations Adjusted for Dead Load Deflection. Rows include Back of W. Abut., CL Brq. W. Abut., A through H, CL Brq. E. Abut., and Back of E. Abut.

BEAM 4

Table with 5 columns: Location, Station, Offset, Theoretical Grade Elevations, Theoretical Grade Elevations Adjusted for Dead Load Deflection. Rows include Back of W. Abut., CL Brq. W. Abut., A through H, CL Brq. E. Abut., and Back of E. Abut.

STAGE II CONSTRUCTION LINE

Table with 5 columns: Location, Station, Offset, Theoretical Grade Elevations, Theoretical Grade Elevations Adjusted for Dead Load Deflection. Rows include Back of W. Abut., CL Brq. W. Abut., A through H, CL Brq. E. Abut., and Back of E. Abut.

FILE NAME = s:\jpl\63308-6399\6346\027\micro\final\plans\structure\0370174-64C2P-004-TSE.dgn



Table with 2 columns: USER NAME = brianf, DESIGNED MJD, CHECKED AJS, DRAWN BJF, CHECKED RRD, PLOT SCALE =, PLOT DATE = 7/19/2011, REVISED -

STATE OF ILLINOIS DEPARTMENT OF TRANSPORTATION

Table with 2 columns: TOP OF SLAB ELEVATIONS (2 OF 3), STRUCTURE NO. 037-0174, SHEET NO. 5 OF 20 SHEETS

Table with 5 columns: F.A.P. RTE. 585, SECTION 128 BR, COUNTY HENRY, TOTAL SHEETS 106, SHEET NO. 49, CONTRACT NO. 64C20, ILLINOIS FED. AID PROJECT

NORTH EDGE OF SHOULDER

Location	Station	Offset	Theoretical Grade Elevations
W. End West Appr. Slab	625+04.45	20.00	611.49
A1	625+14.45	20.00	611.53
A2	625+24.45	20.00	611.57
E. End West Appr. Slab	625+34.45	20.00	611.60
W. End East Appr. Slab	626+25.89	20.00	611.57
A3	626+35.89	20.00	611.54
A4	626+45.89	20.00	611.50
E. End East Appr. Slab	626+55.89	20.00	611.45

NORTH EDGE OF PAVEMENT

Location	Station	Offset	Theoretical Grade
W. End West Appr. Slab	624+99.45	12.00	611.63
A1	625+09.45	12.00	611.68
A2	625+19.45	12.00	611.72
E. End West Appr. Slab	625+29.45	12.00	611.75
W. End East Appr. Slab	626+20.89	12.00	611.76
A3	626+30.89	12.00	611.72
A4	626+40.89	12.00	611.69
E. End East Appr. Slab	626+50.89	12.00	611.64

☉ ROADWAY / PROFILE GRADE LINE / STAGE CONSTRUCTION LINE

Location	Station	Offset	Theoretical Grade
W. End West Appr. Slab	624+91.95	0.00	611.78
A1	625+01.95	0.00	611.83
A2	625+11.95	0.00	611.88
E. End West Appr. Slab	625+21.95	0.00	611.92
W. End East Appr. Slab	626+13.39	0.00	611.96
A3	626+23.39	0.00	611.94
A4	626+33.39	0.00	611.90
E. End East Appr. Slab	626+43.39	0.00	611.86

SOUTH EDGE OF SHOULDER

Location	Station	Offset	Theoretical Grade
W. End West Appr. Slab	624+79.45	-20.00	611.35
A1	624+89.45	-20.00	611.41
A2	624+99.45	-20.00	611.47
E. End West Appr. Slab	625+09.45	-20.00	611.51
W. End East Appr. Slab	626+00.89	-20.00	611.63
A3	626+10.89	-20.00	611.61
A4	626+20.89	-20.00	611.59
E. End East Appr. Slab	626+30.89	-20.00	611.56

SOUTH EDGE OF PAVEMENT

Location	Station	Offset	Theoretical Grade
W. End West Appr. Slab	624+84.45	-12.00	611.55
A1	624+94.45	-12.00	611.61
A2	625+04.45	-12.00	611.66
E. End West Appr. Slab	625+14.45	-12.00	611.70
W. End East Appr. Slab	626+05.89	-12.00	611.79
A3	626+15.89	-12.00	611.77
A4	626+25.89	-12.00	611.74
E. End East Appr. Slab	626+35.89	-12.00	611.71

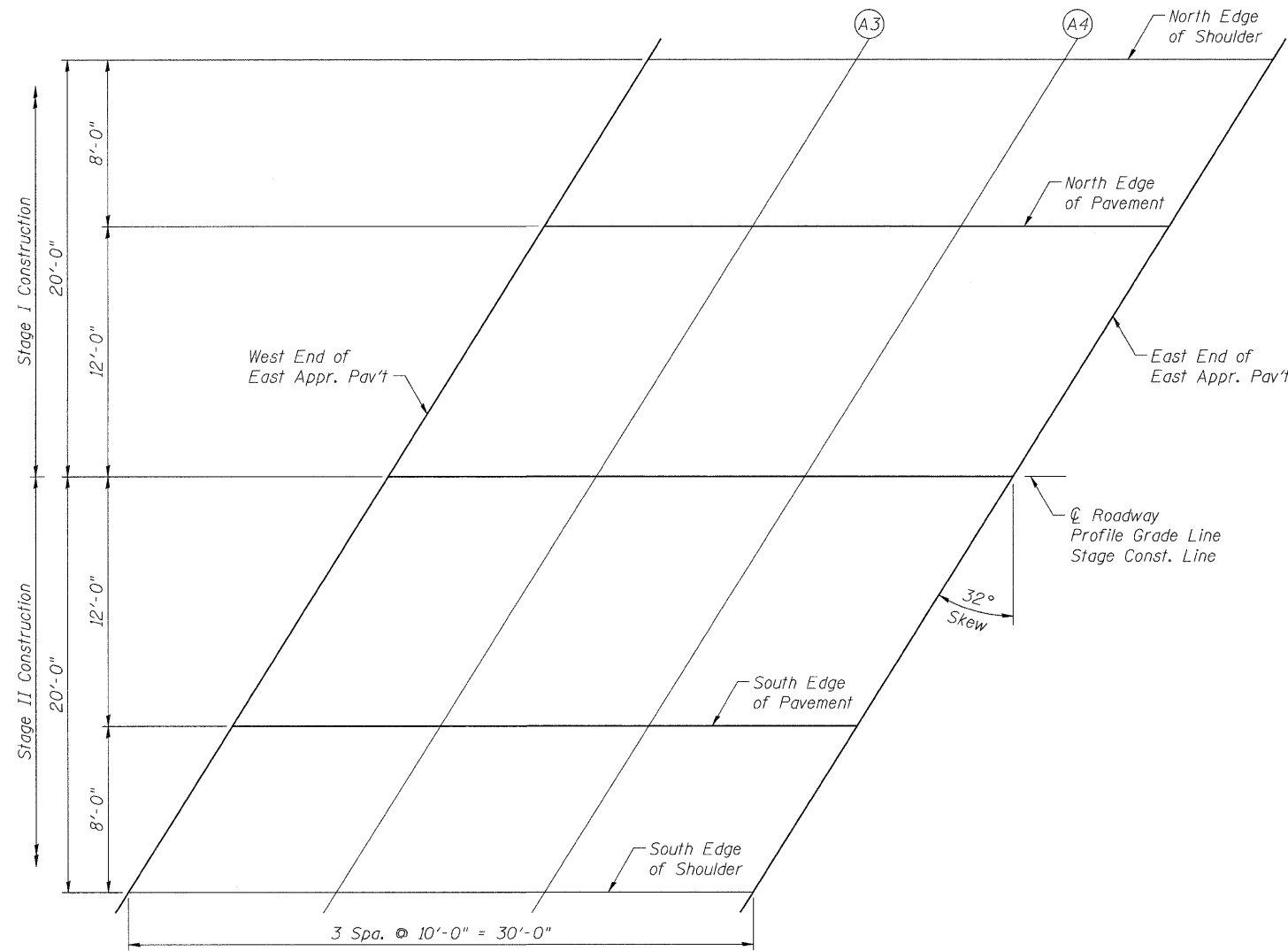
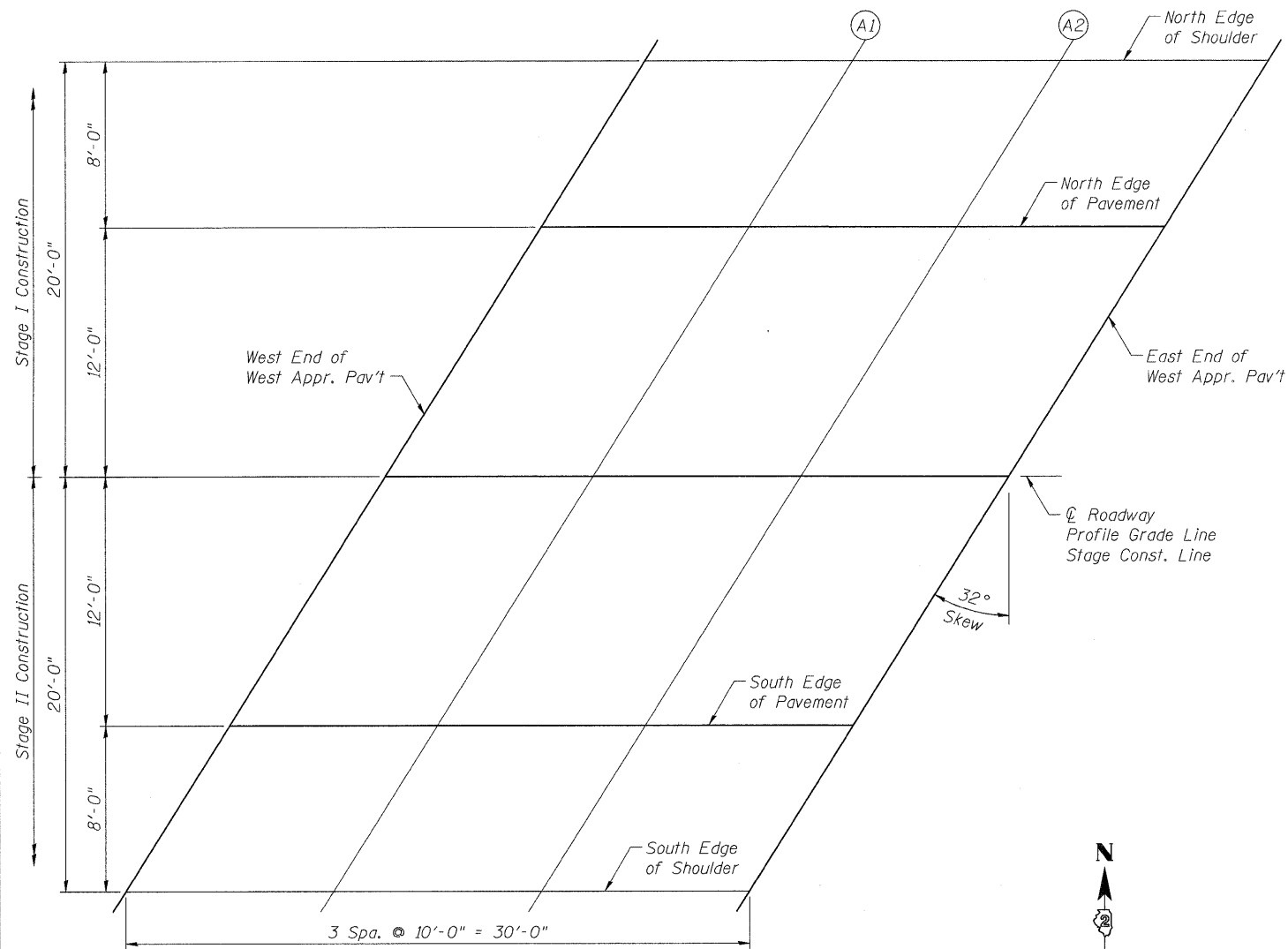

FILE NAME = s:\p1\6300-6395\6346\027\micro\final\plans\structural\0370174-6420-004-1SE.dgn

STRAND ASSOCIATES, INC.
ENGINEERS

1170 SOUTH HOUBOLT ROAD
JOLIET, ILLINOIS 60431
(815) 744-4200

USER NAME = brianf	DESIGNED <i>MJD</i>	REVISED -
PLOT SCALE =	CHECKED <i>AJS</i>	REVISED -
PLOT DATE = 7/19/2011	DRAWN <i>BjF</i>	REVISED -
	CHECKED <i>RRD</i>	REVISED -

DESIGNED <i>MJD</i>	REVISED -
CHECKED <i>AJS</i>	REVISED -
DRAWN <i>BjF</i>	REVISED -
CHECKED <i>RRD</i>	REVISED -

**STATE OF ILLINOIS
DEPARTMENT OF TRANSPORTATION**

**TOP OF SLAB ELEVATIONS (3 OF 3)
STRUCTURE NO. 037-0174**

SHEET NO. 6 OF 20 SHEETS

F.A.P. RTE. 585	SECTION 128 BR	COUNTY HENRY	TOTAL SHEETS 106	SHEET NO. 50
CONTRACT NO. 64C20				
ILLINOIS FED. AID PROJECT				

* Order a(E) and a₃(E) bars full length.
Cut to fit skew and use remainder
of bars in opposite end.

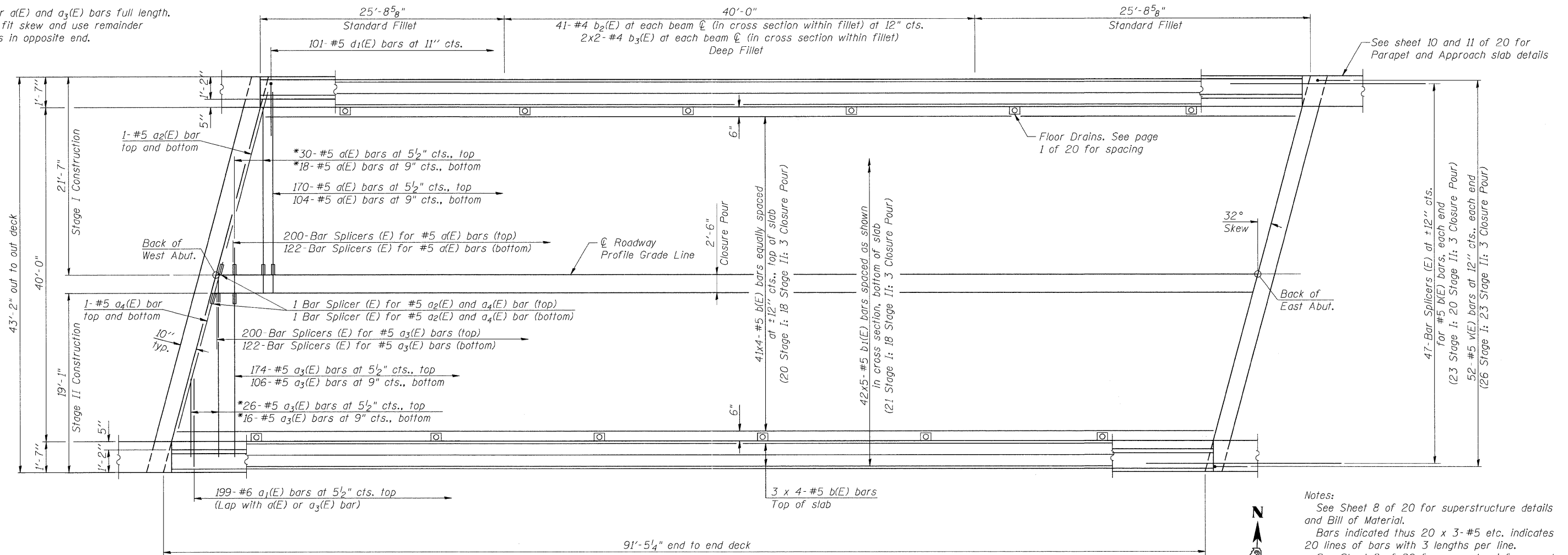

Notes:
See Sheet 8 of 20 for superstructure details and Bill of Material.
Bars indicated thus 20 x 3-#5 etc. indicates 20 lines of bars with 3 lengths per line.
See Sheet 8 of 20 for parapet reinforcement.
See Sheet 9 of 20 for diaphragm details and reinforcement.

PLAN

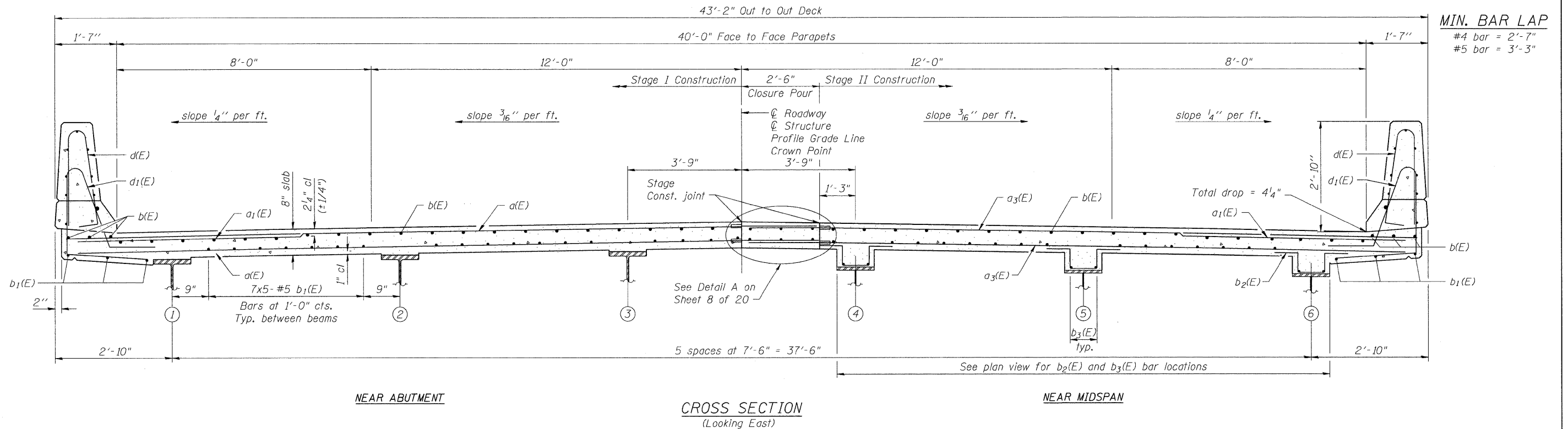

NEAR ABUTMENT

CROSS SECTION
(Looking East)

NEAR MIDSPAN

FILE NAME = ar_jp1\6300-6999\6346\027\microe\final_plans\structure\0370174-64C20-007-S.P.dgn

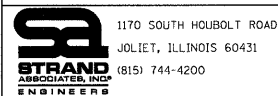

1170 SOUTH HOUBOLT ROAD
JOLIET, ILLINOIS 60431
(815) 744-4200

USER NAME = branzf	DESIGNED MJD	REVISED -
PLOT SCALE =	CHECKED AJS	REVISED -
PLOT DATE = 7/19/2011	DRAWN BJF	REVISED -
	CHECKED RRD	REVISED -

STATE OF ILLINOIS
DEPARTMENT OF TRANSPORTATION

SUPERSTRUCTURE
STRUCTURE NO. 037-0174

SHEET NO. 7 OF 20 SHEETS

F.A.P. RTE. 585	SECTION 128 BR	COUNTY HENRY	TOTAL SHEETS 106	SHEET NO. 51
CONTRACT NO. 64C20				
ILLINOIS FED. AID PROJECT				

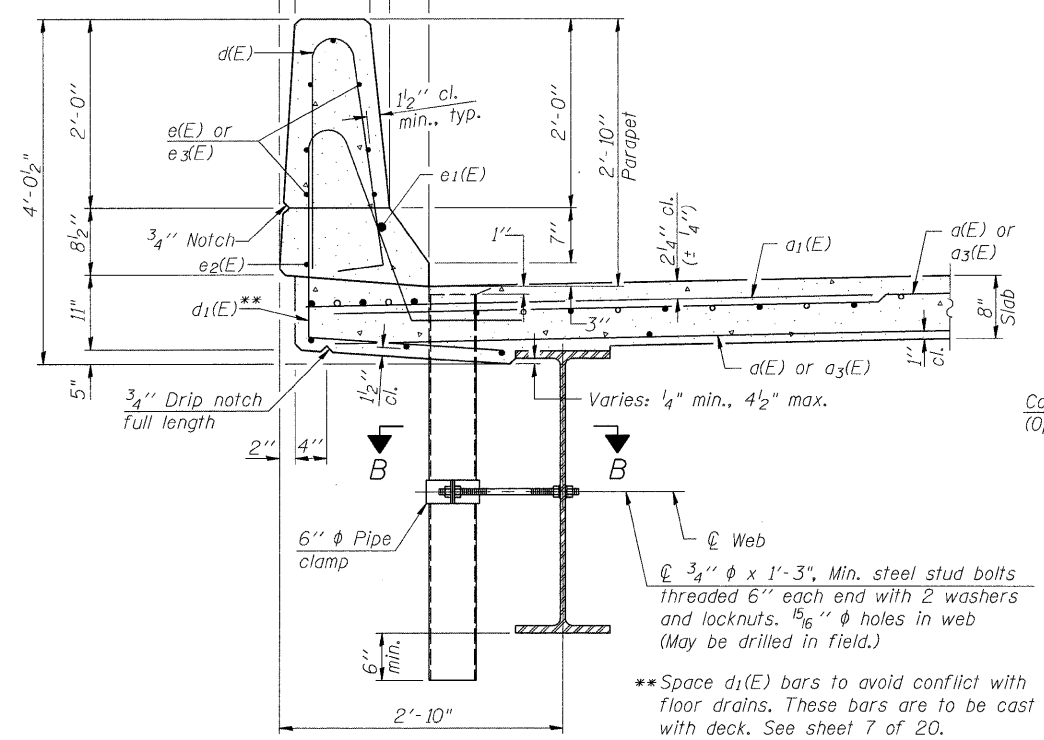
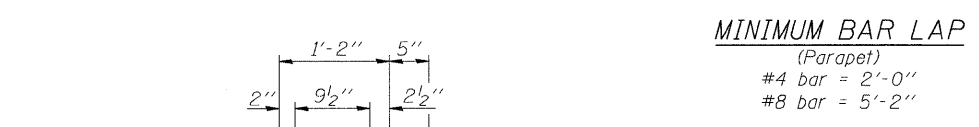
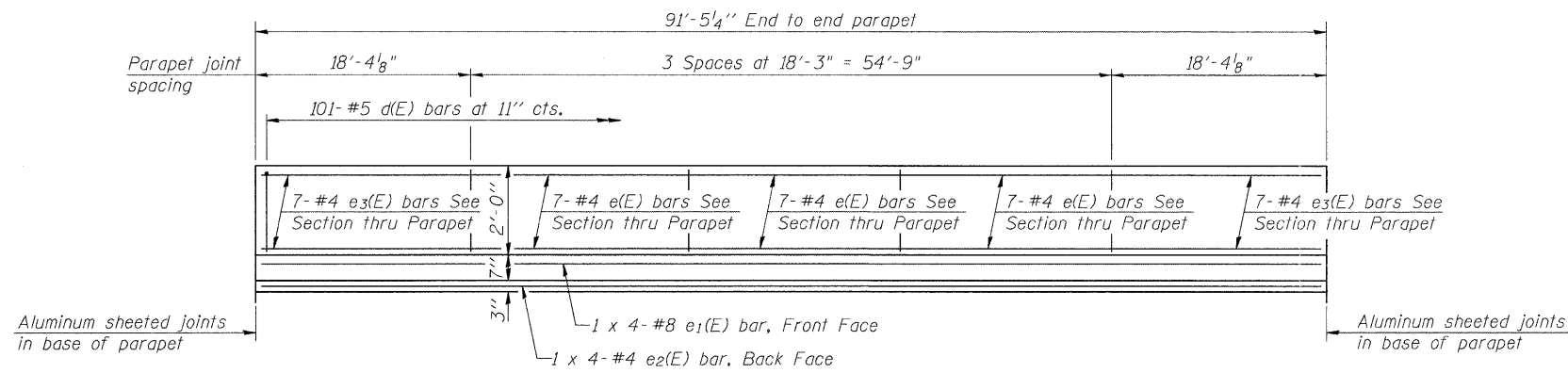

SECTION THRU PARAPET

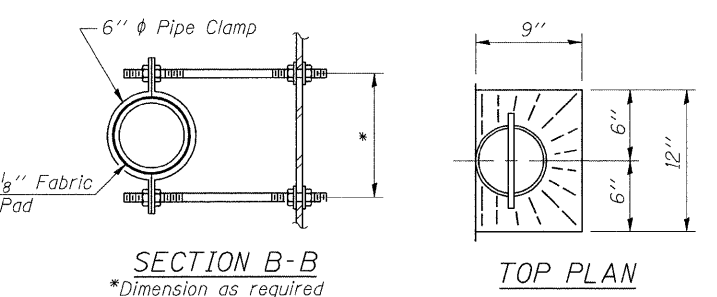

SECTION B-B
*Dimension as required by Pipe Clamp

TOP PLAN

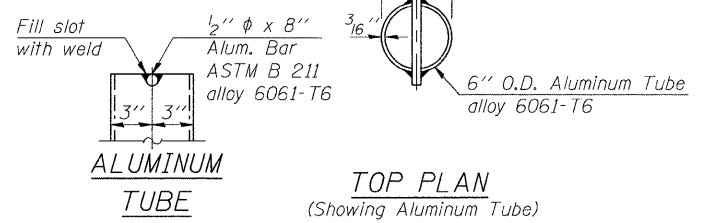

ALUMINUM TUBE
TOP PLAN (Showing Aluminum Tube)

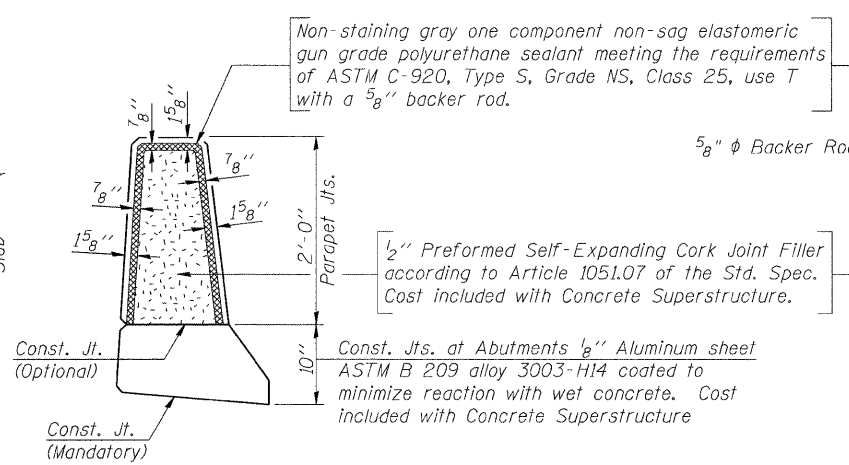

PARAPET JOINT DETAILS

Notes:
The exterior surfaces of the floor drains shall be painted with the finish coat as specified in the special provisions for Cleaning and Painting New Metal Structures. The exterior surfaces of the drains shall be cleaned according to Society of Protective Coatings Spec. SSPC-SP1 prior to painting.
Galvanize clamping device according to AASHTO M232. Cost of clamping device and inserts is included with Floor Drains.

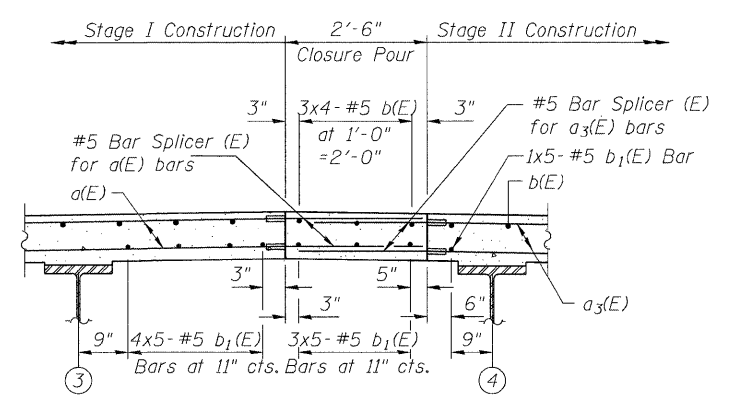

DETAIL A

SUPERSTRUCTURE
BILL OF MATERIAL

Bar	No.	Size	Length	Shape
a(E)	322	#5	21'-3"	—
a1(E)	398	#5	6'-6"	—
a2(E)	4	#5	25'-0"	—
a3(E)	322	#5	18'-9"	—
a4(E)	4	#5	22'-2"	—
b(E)	188	#5	25'-4"	—
b1(E)	210	#5	21'-0"	—
b2(E)	246	#4	3'-6"	U
b3(E)	24	#4	21'-4"	—
d(E)	202	#5	5'-7"	J
d1(E)	202	#5	7'-6"	J
e(E)	42	#4	17'-11"	—
e1(E)	8	#8	26'-9"	—
e2(E)	8	#4	24'-5"	—
e3(E)	28	#4	18'-0"	—
m(E)	20	#6	25'-1"	—
m1(E)	10	#6	8'-6"	—
m2(E)	4	#6	3'-0"	—
m3(E)	24	#6	12'-6"	—
s(E)	92	#5	6'-10"	J
s1(E)	84	#4	10'-11"	U
v(E)	104	#5	3'-9"	L
Reinforcement Bars, Epoxy Coated		Pound	34,140	
Concrete Superstructure		Cu. Yds.	168	

Bars indicated thus 1x4-#5 etc. indicates 1 line of bars with 4 lengths per line.

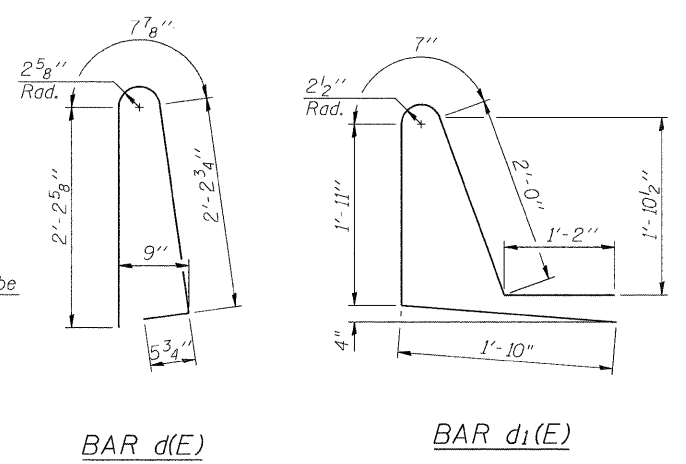

BAR d(E)

BAR d1(E)

BAR v(E)

FILE NAME = S:\JDL\63200-6399\6346-027\Misc\Final Plans\Structure\0370174-64C20-808-SUPDET.dgn



1170 SOUTH HOUBOLT ROAD JOLIET, ILLINOIS 60431 (815) 744-4200	USER NAME = brianf DESIGNED MJD CHECKED AJS DRAWN B/JF PLOT DATE = 8/11/2011	DESIGNED MJD CHECKED AJS DRAWN B/JF CHECKED RRD	REVISED - REVISED - REVISED - REVISED -
---	--	--	--

STATE OF ILLINOIS
DEPARTMENT OF TRANSPORTATION

SUPERSTRUCTURE DETAILS
STRUCTURE NO. 037-0174

SHEET NO. 8 OF 20 SHEETS

F.A.P. RTE. 585	SECTION 128 BR	COUNTY HENRY	TOTAL SHEETS 106	SHEET NO. 52
				CONTRACT NO. 64C20
ILLINOIS FED. AID PROJECT				

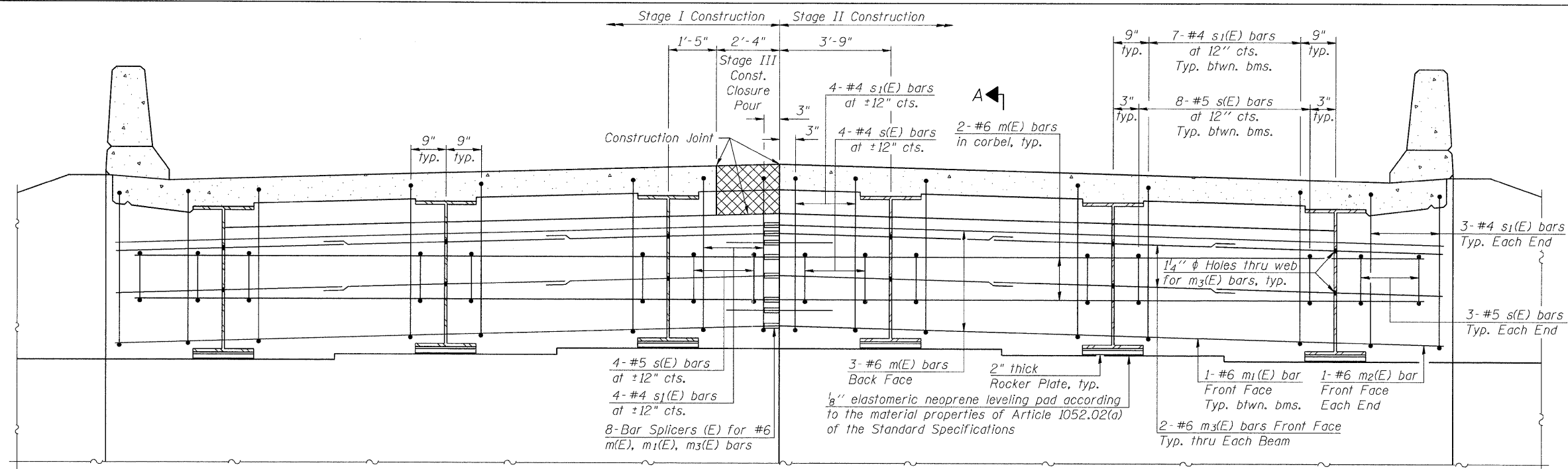

DIAPHRAGM ELEVATION AT ABUTMENT

Notes:
 Reinforcement bars in diaphragm are billed with superstructure on sheet 8 of 20.
 Concrete in diaphragm is included with Concrete Superstructure on sheet 8 of 20.
 For details of bars s(E) & s₁(E) see sheet 8 of 20.
 The s(E) and s₁(E) bars shall be placed parallel to the beams. Spacing for these bars shall be at right angles to the beams.
 Contractor to cut m₁(E) and m₃(E) bar at Stage Construction Line. Remaining portion of bar to be saved and spliced in Stage II Construction.

MIN. BAR LAP
 #6 bar = 3'-4"

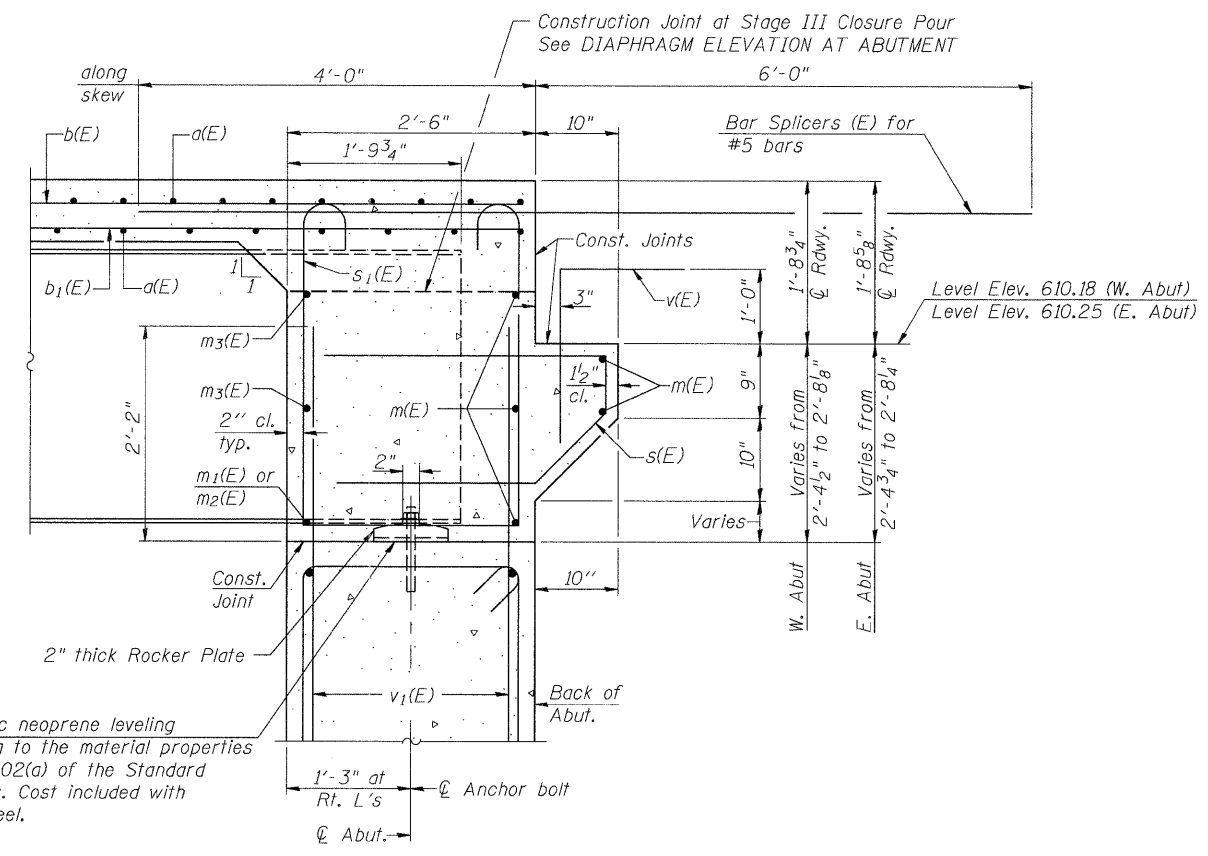

SECTION A-A

Dimensions at right angles to abutment, except as shown.

FILE NAME = st:\p1\6200-6399\6346\227\micos\structural\0370174-64C20-009-DIAPDET.dgn



USER NAME = brianf	DESIGNED MJD	REVISED -
PLOT SCALE =	CHECKED AJS	REVISED -
PLOT DATE = 7/19/2011	DRAWN BJF	REVISED -
	CHECKED RRD	REVISED -

STATE OF ILLINOIS
 DEPARTMENT OF TRANSPORTATION

INTEGRAL ABUTMENT DIAPHRAGM DETAILS
 STRUCTURE NO. 037-0174

F.A.P. RTE. 585	SECTION 128 BR	COUNTY HENRY	TOTAL SHEETS 106	SHEET NO. 53
				CONTRACT NO. 64C20
ILLINOIS FED. AID PROJECT				

Notes:
See sheet 11 of 20 for Sections C-C & D-D and View E-E.
 $a_{10}(E)$ and $a_{11}(E)$ bar spacings measured along ϕ Rdwy.

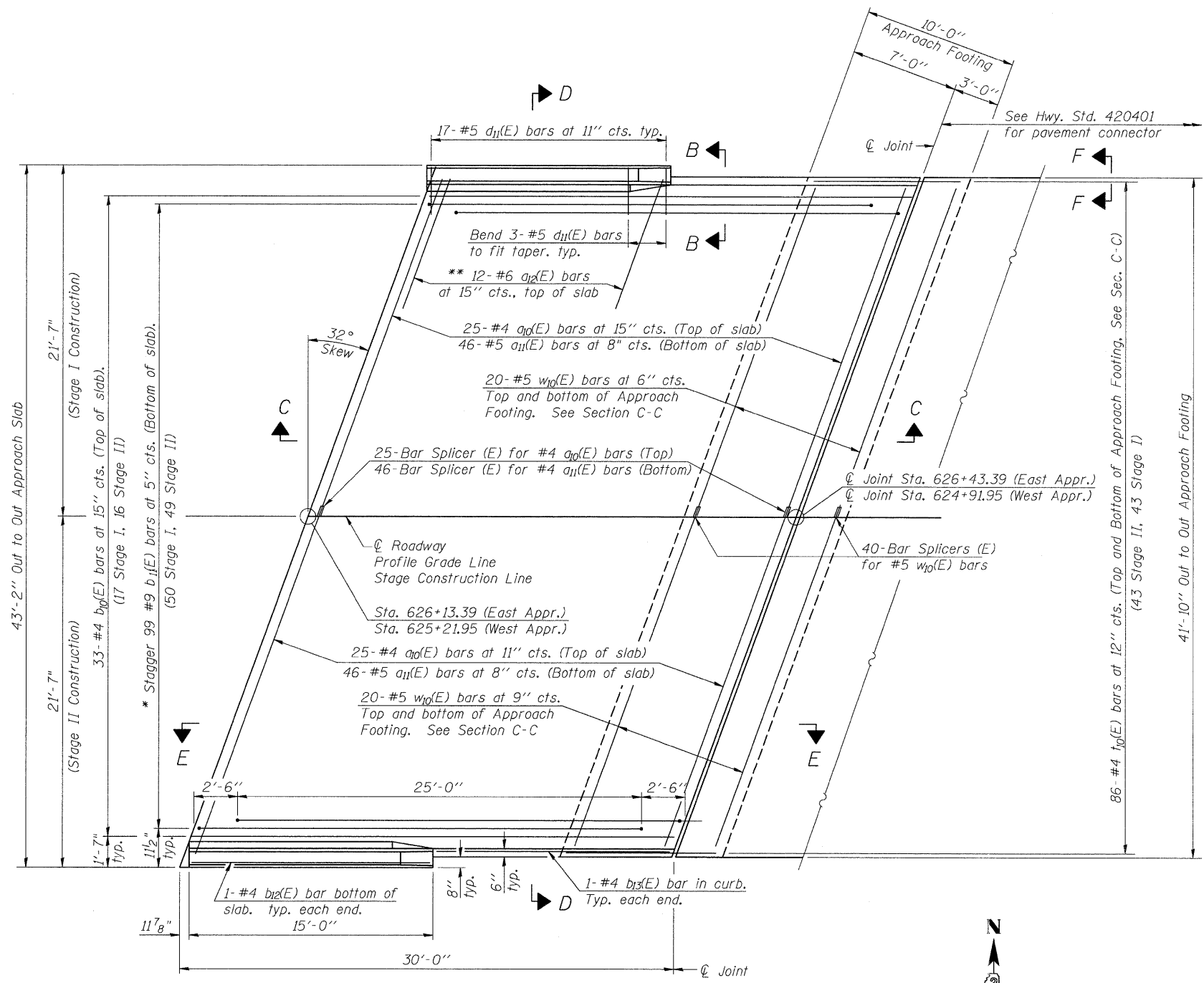

PLAN

* Tilt #9 $b_{11}(E)$ bars as required to maintain clearance.
** Space between $a_{10}(E)$ bars, typ. each parapet.

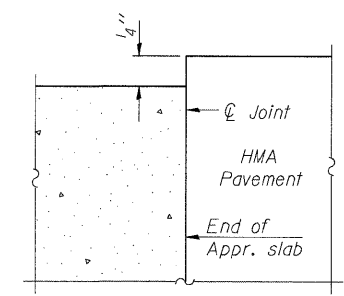
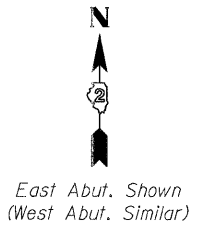

FLEXIBLE PAVEMENT

DETAIL A

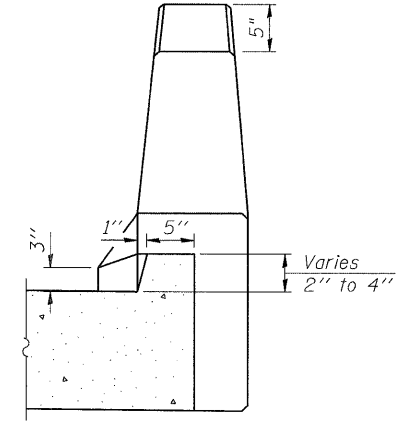

VIEW B-B

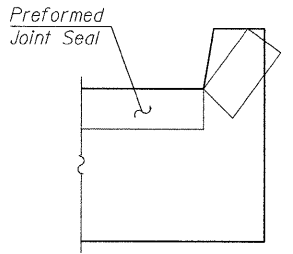

VIEW F-F

Angle Preformed Joint Seal at 45° at curbs when req'd for drainage.

FILE NAME = s:\p\63200-63999\6346\027\micos\1\micos\1\micos\1\0310174-64C20-010-BAP.dgn

BA-L



USER NAME = brianf	DESIGNED MJD	REVISED -
PLLOT SCALE =	CHECKED AJS	REVISED -
PLLOT DATE = 7/19/2011	DRAWN B/JF	REVISED -
	CHECKED RRD	REVISED -

STATE OF ILLINOIS
DEPARTMENT OF TRANSPORTATION

BRIDGE APPROACH SLAB DETAILS (1 OF 2)
STRUCTURE NO. 037-0174

SHEET NO. 10 OF 20 SHEETS

F.A.P. RTE.	SECTION	COUNTY	TOTAL SHEETS	SHEET NO.
585	128 BR	HENRY	106	54
CONTRACT NO. 64C20				
ILLINOIS FED. AID PROJECT				

Notes:
 See sheet 10 of 20 for Detail A and View B-B.
 Approach slab and parapet concrete shall be paid for as Concrete Superstructure.
 Approach footing concrete shall be paid for as Concrete Structures.
 Reinforcement shall be paid for as Reinforcement Bars, Epoxy Coated.
 For v(E) bar details, see sheet 9 of 20.
 The approach footing maximum applied service bearing pressure (Qmax) = 2.0 ksf.
 For bar splicer details, see sheet 17 of 20.
 Cost of excavation for approach footing included with Concrete Structures.
 For Porous Granular Embankment (Special) and drainage treatment details, see sheet 2 of 20.
 For additional parapet details, see sheet 8 of 20.

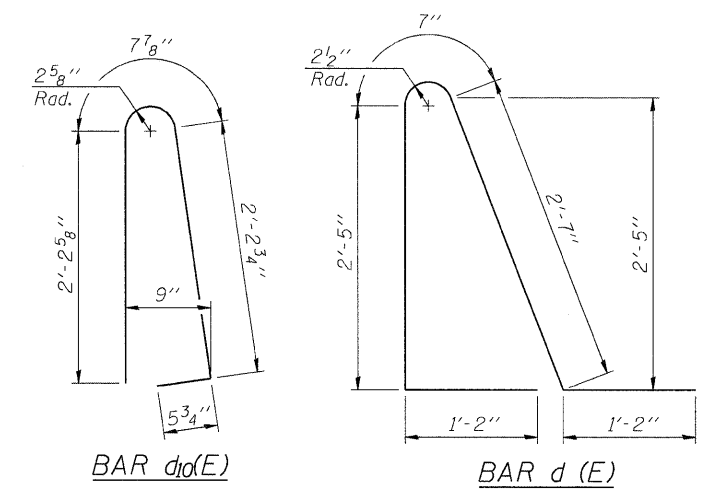
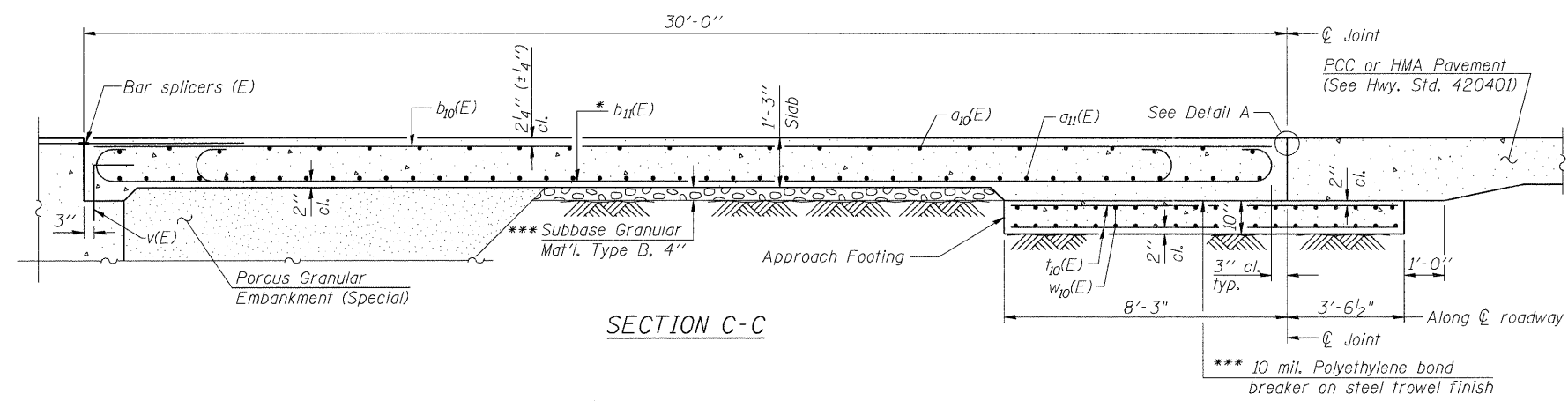

* Tilt #9 b11(E) bars as required to maintain clearance.
 *** Cost included with Concrete Superstructure.

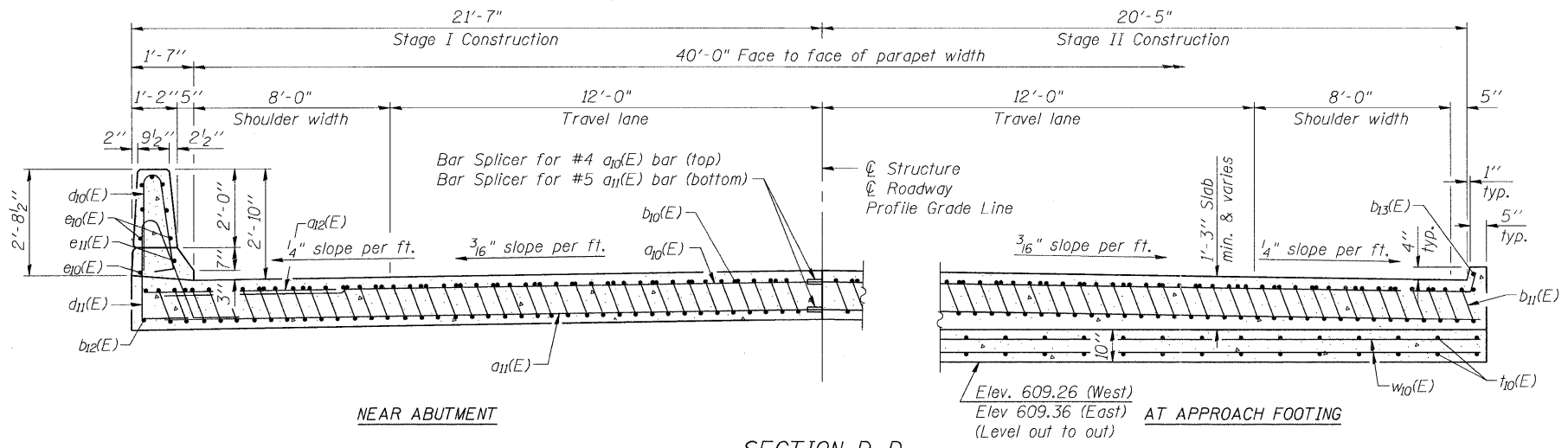

NEAR ABUTMENT

SECTION D-D

(See Plan for dimensions not shown)

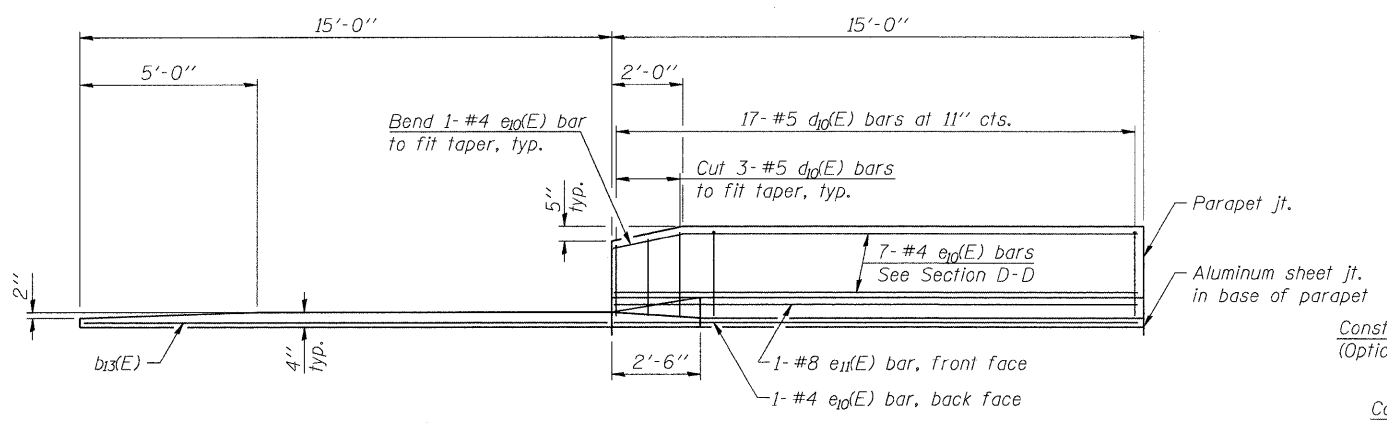

VIEW E-E

PARAPET JOINT DETAILS

TWO APPROACHES
 BILL OF MATERIAL

Bar	No.	Size	Length	Shape
a10(E)	100	#4	24'-8"	—
a11(E)	184	#5	24'-3"	—
a2(E)	48	#6	6'-6"	—
b10(E)	66	#4	29'-8"	—
b11(E)	198	#9	29'-9"	—
b2(E)	4	#4	14'-8"	—
b3(E)	4	#4	15'-8"	—
d10(E)	68	#5	5'-7"	U
d11(E)	68	#5	7'-11"	U
e10(E)	32	#4	14'-8"	—
e11(E)	4	#8	14'-8"	—
h10(E)	172	#4	11'-5"	—
w10(E)	160	#5	24'-4"	—
Reinforcement Bars, Epoxy Coated			Pound	29,620 *
Reinforcement Bars, Epoxy Coated			Pound	5,380 **
Concrete Structures			Cu. Yds.	31
Concrete Superstructure			Cu. Yds.	131

Bars indicated thus 1 x 2-#5 etc. indicates 1 line of bars with 2 lengths per line.
 * Included in Superstructure quantity
 ** Included in Substructure quantity

FILE NAME = s:\jpl\6300-6395\6346\027\micro\struc\1\0370174-64C20-010-BAP.dgn



1170 SOUTH HOUBOLT ROAD
 JOLIET, ILLINOIS 60431
 (815) 744-4200

USER NAME = brianf
 DESIGNED MJD
 CHECKED AJS
 DRAWN B/JF
 CHECKED RRD
 REVISIONS:
 -
 -
 -
 -

STATE OF ILLINOIS
 DEPARTMENT OF TRANSPORTATION

BRIDGE APPROACH SLAB DETAILS (2 OF 2)
 STRUCTURE NO. 037-0174

SHEET NO. 11 OF 20 SHEETS

F.A.P. RTE.	SECTION	COUNTY	TOTAL SHEETS	SHEET NO.
585	128 BR	HENRY	106	55
CONTRACT NO. 64C20				
ILLINOIS FED. AID PROJECT				

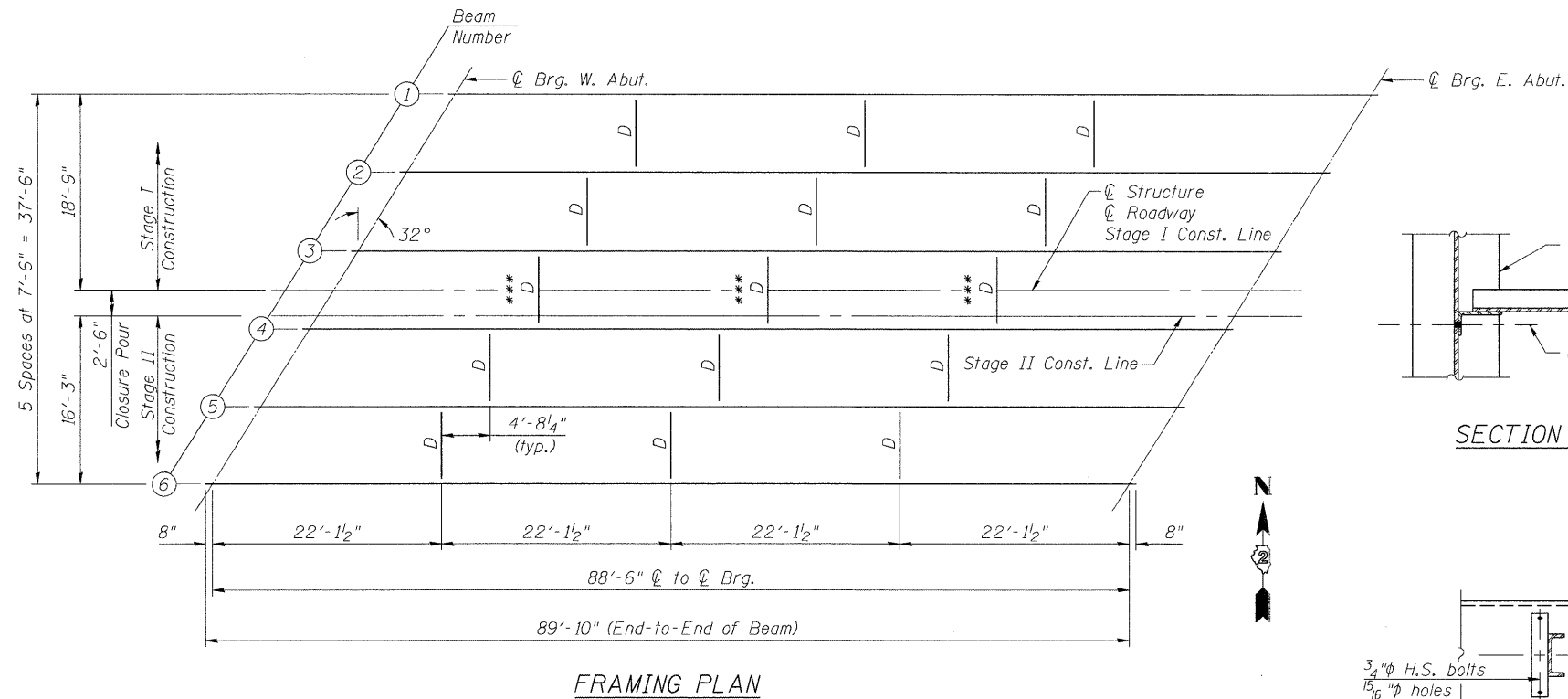

FRAMING PLAN

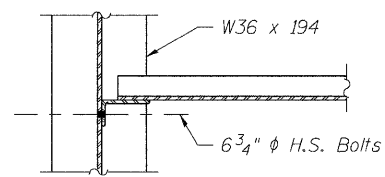

SECTION B-B

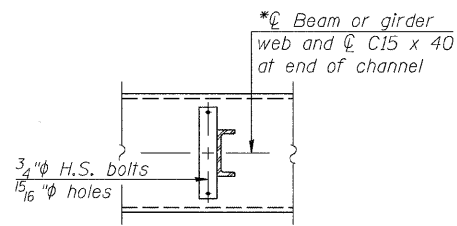

SECTION C-C

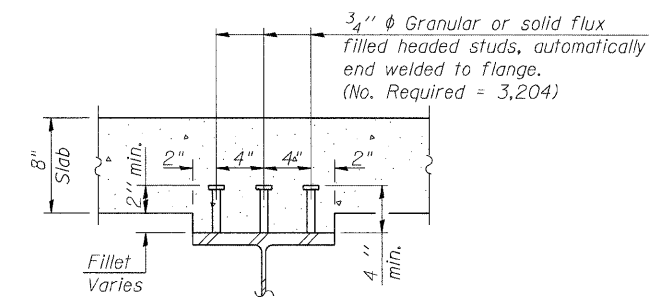

STANDARD INTERIOR FILLET SECTION

See Sheet 7 of 20 for locations.

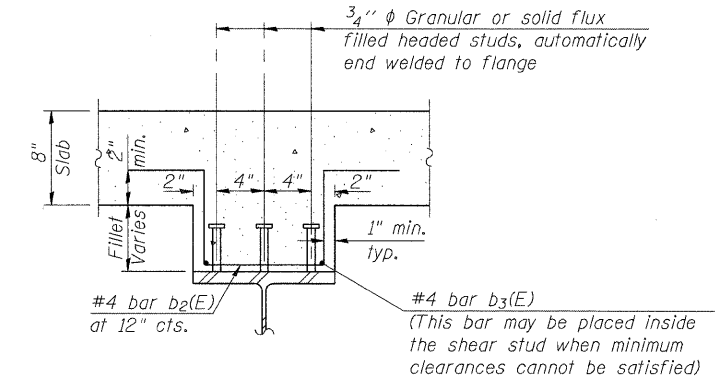

DEEP INTERIOR FILLET SECTION

See Sheet 7 of 20 for locations.

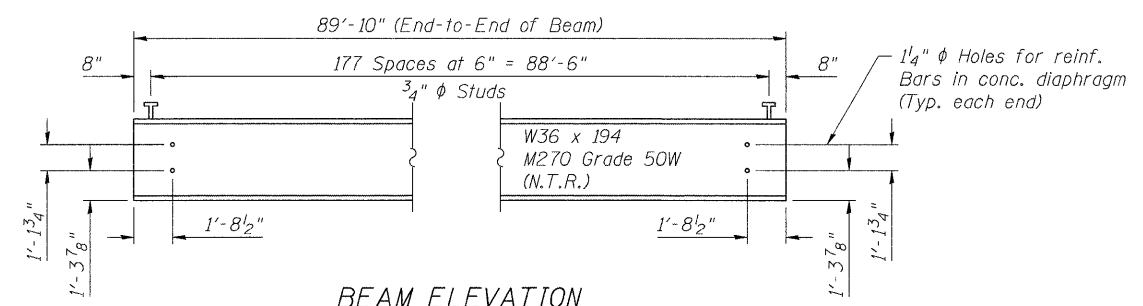

BEAM ELEVATION

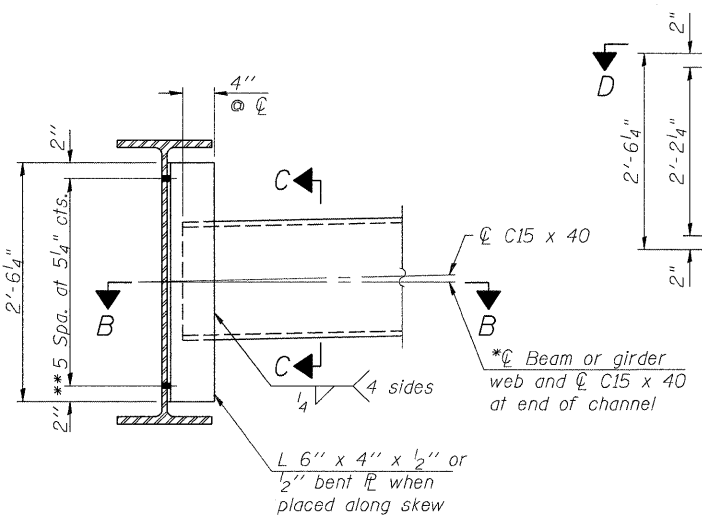

INTERIOR DIAPHRAGM D

(15 Required)

Note:
Two hardened washers required for each set of oversized holes.
*C15X50 is permitted to facilitate material acquisition. Calculated weight of structural steel is based on the lighter section. The alternate, if utilized, shall be provided at no additional cost to the Department.
** 3/4" H.S. bolts, 1 5/16" holes
*** Temporary Bracing shall be provided during Stage II Construction and replaced with diaphragm D prior to pouring Deck Closure Pour.

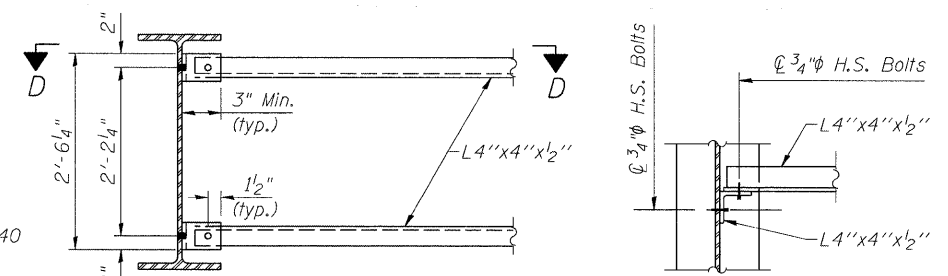

SECTION D-D

*** TEMPORARY BRACING DETAIL

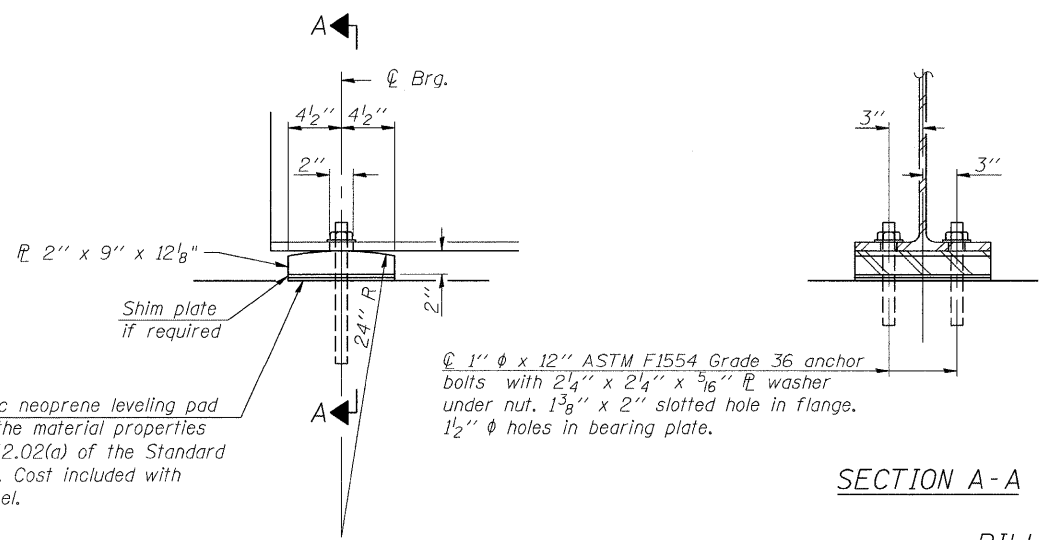

ELEVATION AT ABUTMENT

BEARING DETAIL

BILL OF MATERIAL

ITEM	UNIT	TOTAL
Anchor bolts, 1"	Each	24

NOTES:

Load carrying components designated "NTR" shall conform to the Supplemental Requirements for Notch Toughness, Zone 2.
All diaphragms shall be installed as steel is erected and secured with erection pins and bolts except as otherwise noted. Individual diaphragms at supports may be temporarily disconnected to install bearing anchor rods.
Drilled and set anchor bolts shall be installed according to Article 521.06 of the Standard Specifications.
All beams shall be W36x194 AASHTO M20 Grade 50W (NTR). All diaphragms and connecting angles shall be AASHTO M270 Grade 50W. All bearing plates shall be AASHTO M270 Grade 50W.
Anchor bolts shall be ASTM F1554 all-thread (or an Engineer-approved alternate material) of the grade(s) and diameter(s) specified. ASTM A307 Grade C anchor bolts may be used in lieu of ASTM F1554 Grade 36 (fy=36ksi). The corresponding specified grade of AASHTO M314 anchor bolts may be used in lieu of ASTM F1554.
Structural steel for temporary bracing shall be AASHTO M270 Grade 36 and is not required to be painted. Cost included with Structural Steel.

FILE NAME = S:\JLD\63809--6399\6346\027\Micro\Plan\Structural\0370174-64C20-012-BEAM.dgn



USER NAME = brionf	DESIGNED MJD	REVISED -
PLOT SCALE =	CHECKED AJS	REVISED -
PLOT DATE = 8/11/2011	DRAWN B/JF	REVISED -
	CHECKED RRD	REVISED -

STATE OF ILLINOIS
DEPARTMENT OF TRANSPORTATION

STEEL FRAMING PLAN AND BEAM DETAILS
STRUCTURE NO. 037-0174

SHEET NO. 12 OF 20 SHEETS

F.A.P. RTE. 585	SECTION 128 BR	COUNTY HENRY	TOTAL SHEETS 106	SHEET NO. 56
CONTRACT NO. 64C20				ILLINOIS FED. AID PROJECT

***TOP OF BEAM ELEVATIONS**

Beam Number	CL Brg. W. Abut	CL Brg. E. Abut
1	610.80	610.77
2	610.94	610.94
3	611.04	611.06
4	611.04	611.06
5	610.89	610.97
6	610.72	610.83

*For fabrication only

INTERIOR GIRDER MOMENT TABLE		
		0.5 Sp.
I_s	(in ⁴)	12,100
$I_c(n)$	(in ⁴)	36,010
$I_c(3n)$	(in ⁴)	25,244
S_s	(in ³)	664
$S_c(n)$	(in ³)	1,061
$S_c(3n)$	(in ³)	937
Z	(in ³)	767
DC1	(k/')	1.003
M _{DC1}	(k)	982
DC2	(k/')	0.150
M _{DC2}	(k)	147
DW	(k/')	0.375
M _{DW}	(k)	367
$M_L + IM$	(k)	1,459
M_u (Strength I)	(k)	4,505
$\phi_r M_n$	(k)	5,072
f_s DC1	(ksi)	17.6
f_s DC2	(ksi)	1.88
f_s DW	(ksi)	4.7
f_s 1.3(L+IM)	(ksi)	21.45
f_s (Service II)	(ksi)	45.62
f_s (Total)(Strength I)	(ksi)	-
V _r	(k)	60.20

* Compact sections

INTERIOR GIRDER REACTION TABLE		
		Abut.
R _{DC1}	(k)	45.32
R _{DC2}	(k)	6.64
R _{DW}	(k)	16.59
R _{L + IM}	(k)	99.85
R _{Total}	(k)	168.40

I_s, S_s : Non-composite moment of inertia and section modulus of the steel section used for computing f_s (Total-Strength I, and Service II) due to non-composite dead loads (in.⁴ and in.³).

$I_c(n), S_c(n)$: Composite moment of inertia and section modulus of the steel and deck based upon the modular ratio, "n", used for computing f_s (Total-Strength I, and Service II) due to short-term composite live loads (in.⁴ and in.³).

$I_c(3n), S_c(3n)$: Composite moment of inertia and section modulus of the steel and deck based upon 3 times the modular ratio, "3n", used for computing f_s (Total-Strength I, and Service II) due to long-term composite (superimposed) dead loads (in.⁴ and in.³).

Z: Plastic Section Modulus of the steel section in non-composite areas. Omit line in Moment Table if not used in design calculations (in.³).

DC1: Un-factored non-composite dead load (kips/ft.).

M_{DC1}: Un-factored moment due to non-composite dead load (kip-ft.).

DC2: Un-factored long-term composite (superimposed excluding future wearing surface) dead load (kips/ft.).

M_{DC2}: Un-factored moment due to long-term composite (superimposed excluding future wearing surface) dead load (kip-ft.).

DW: Un-factored long-term composite (superimposed future wearing surface only) dead load (kips/ft.).

M_{DW}: Un-factored moment due to long-term composite (superimposed future wearing surface only) dead load (kip-ft.).

$M_L + IM$: Un-factored live load moment plus dynamic load allowance (impact) (kip-ft.).

M_u (Strength I): Factored design moment (kip-ft.).
1.25 (M_{DC1} + M_{DC2}) + 1.5 M_{DW} + 1.75 M_{L + IM}

$\phi_r M_n$: Compact composite positive moment capacity computed according to Article 6.10.7.1 (kip-ft.).

f_s (Service II): Sum of stresses as computed from the moments below (ksi).
M_{DC1} + M_{DC2} + M_{DW} + 1.3 M_{L + IM}

f_s (Total)(Strength I): Sum of stresses as computed from the moments below on non-compact section (ksi).
1.25 (M_{DC1} + M_{DC2}) + 1.5 M_{DW} + 1.75 M_{L + IM}

V_r: Maximum factored shear range in composite portion of span computed according to Article 6.10.10.

FILE NAME = s:\p\63400-6399\6346\027\micro\final\plans\structural\0370174-64C20-013-MOMENT.dgn

Notes:
Pour steps monolithically with cap.

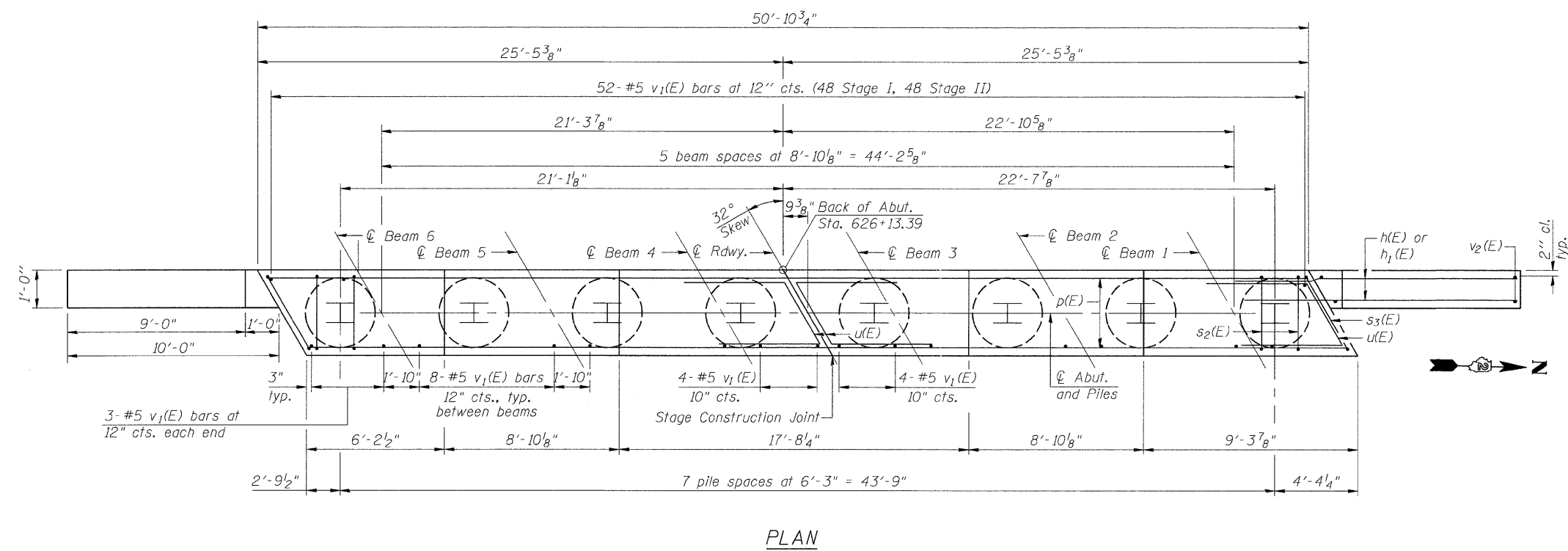
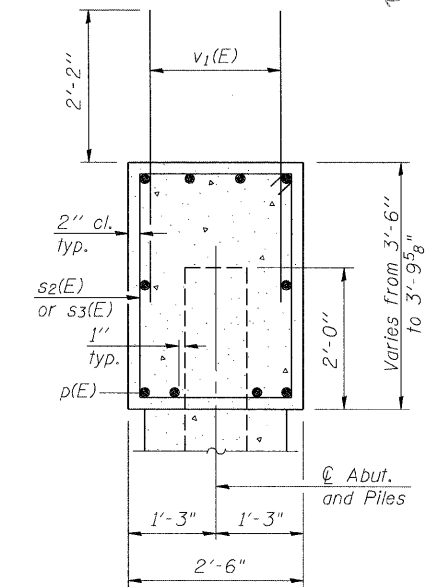
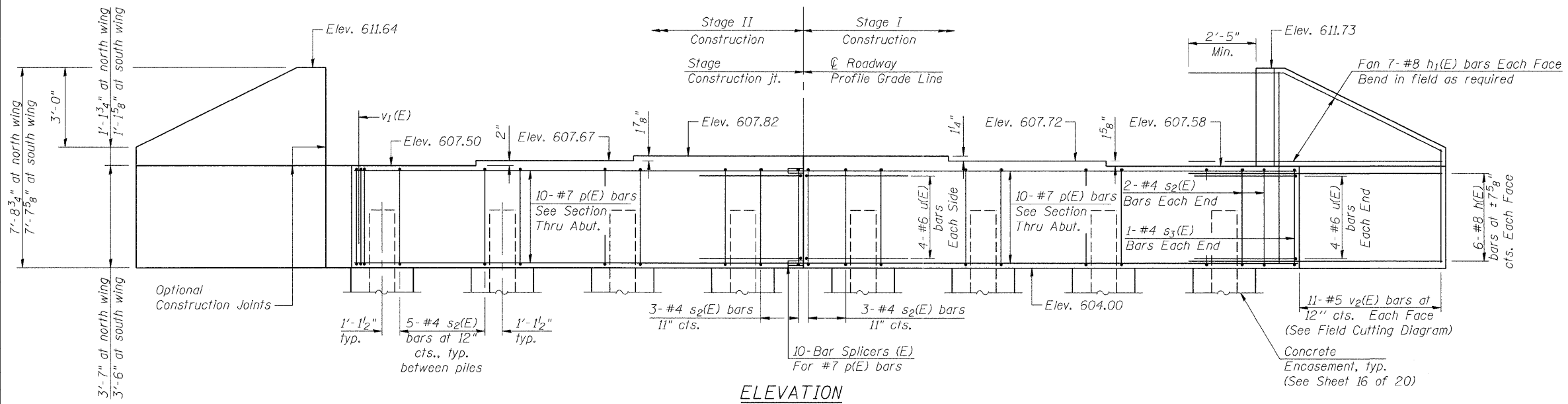

BILL OF MATERIAL

Bar	No.	Size	Length	Shape
h(E)	24	#8	16'-9"	—
h1(E)	28	#8	12'-11"	—
p(E)	20	#7	25'-1"	—
s2(E)	40	#4	11'-5"	□
s3(E)	2	#4	12'-3"	□
u(E)	16	#6	10'-2"	∩
v1(E)	98	#5	4'-4"	—
v2(E)	22	#5	11'-6"	—
Structure Excavation		Cu. Yd.	213	
Concrete Structures		Cu. Yd.	24	
Concrete Encasement		Cu. Yd.	3	
Reinforcement Bars, Epoxy Coated		Pound	4,330	
Furnishing Steel Piles HP 12x53		Foot	644	
Driving Piles		Foot	644	
Test Pile Steel HP 12x53		Each	1	
Geocomposite Wall Drain		Sq. Yd.	50	

For details of Bar Splicers, see sheet 17 of 20.
For details of piles and Concrete Encasement, see sheet 16 of 20.

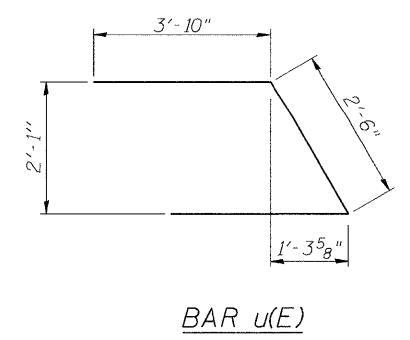
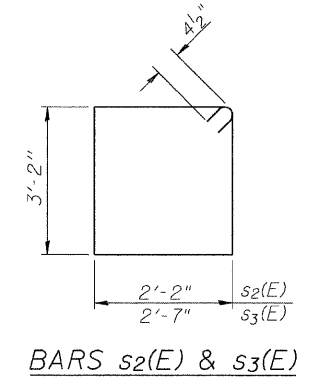
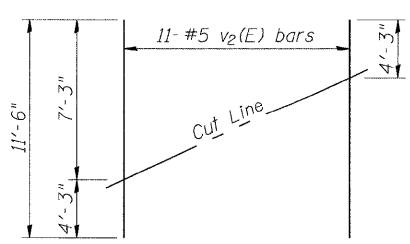

PILE DATA

Type: HP12x53
Nominal Required Bearing: 400 Kips
Factored Resistance Available: 200 Kips
Est. Length: 92 Feet/Pile
No. Production Piles: 7
No. Test Piles: 1

FILE NAME = S:\JDL\6300-6399\6346\02\Work\Final Plans\Structural\0370174-64C20-014-ABUT.dgn

AI-L

7-1-10



USER NAME = brianf	DESIGNED MJD	REVISED -
PLOT SCALE =	CHECKED AJS	REVISED -
PLOT DATE = 8/11/2011	DRAWN BJF	REVISED -
	CHECKED RRD	REVISED -

DESIGNED MJD	REVISED -
CHECKED AJS	REVISED -
DRAWN BJF	REVISED -
CHECKED RRD	REVISED -

STATE OF ILLINOIS
DEPARTMENT OF TRANSPORTATION

WEST ABUTMENT DETAILS
STRUCTURE NO. 037-0174

SHEET NO. 14 OF 20 SHEETS

F.A.P. RTE. 585	SECTION 128 BR	COUNTY HENRY	TOTAL SHEETS 106	SHEET NO. 58
CONTRACT NO. 64C20				ILLINOIS FED. AID PROJECT

Notes:
Pour steps monolithically with cap.

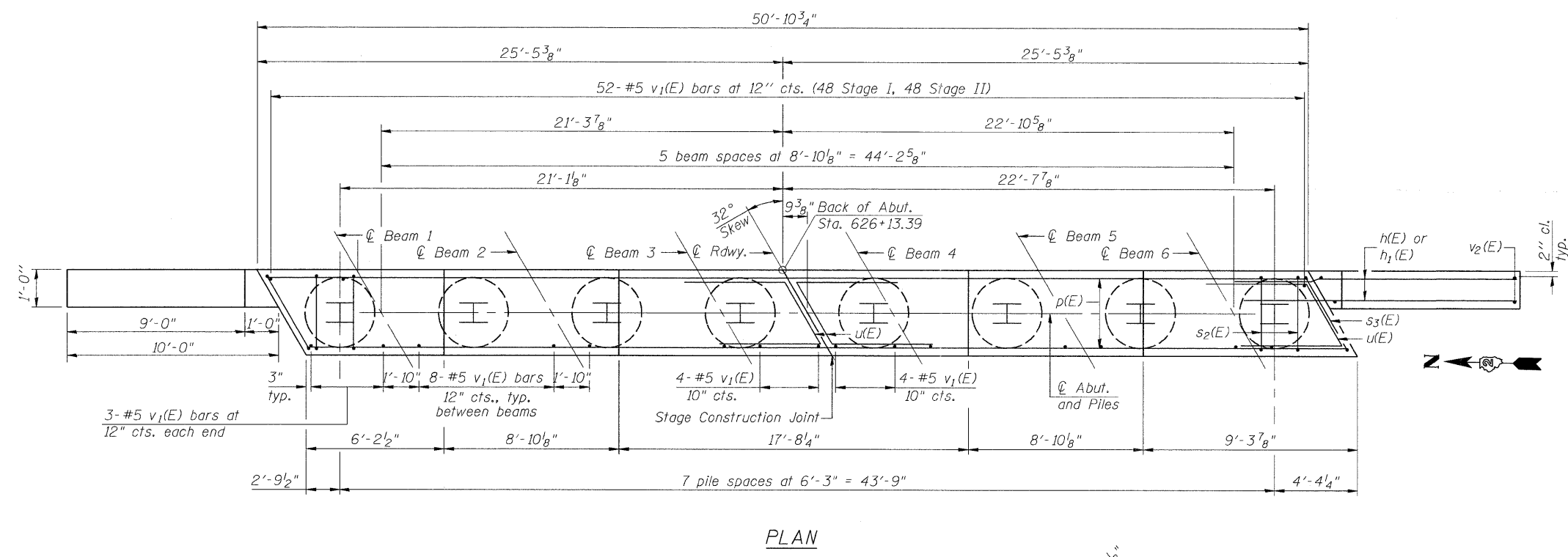
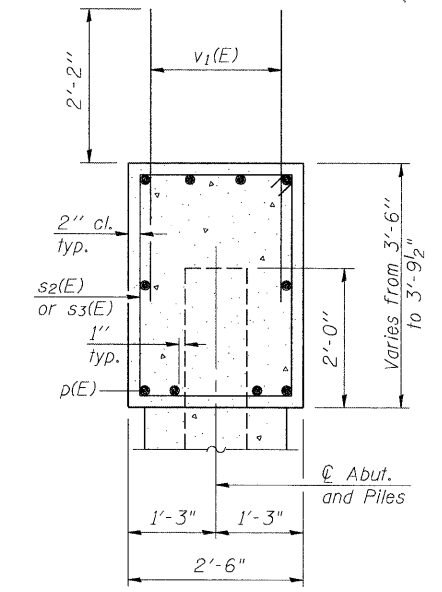
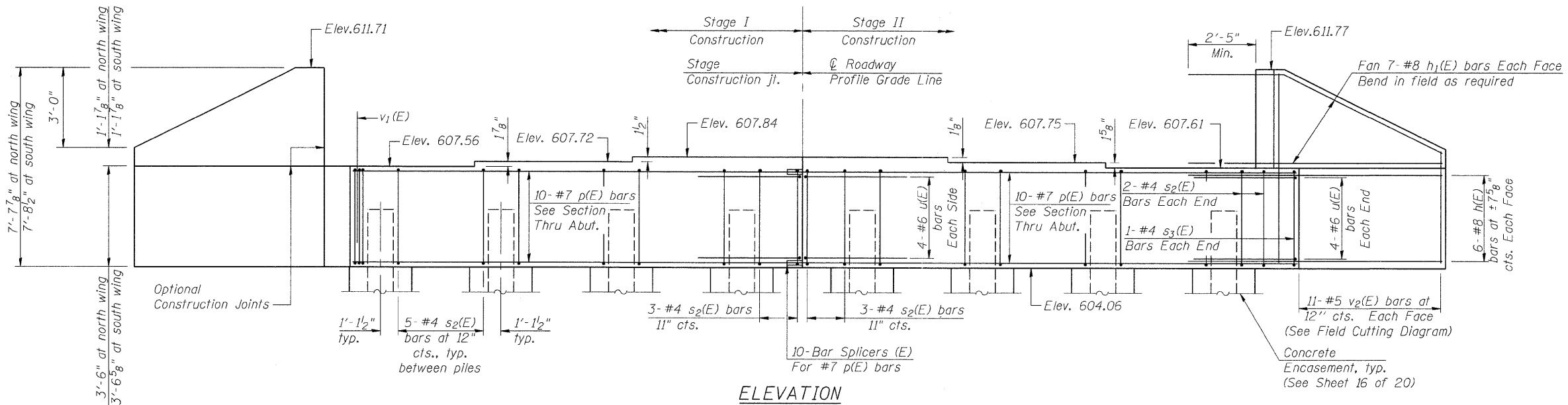

BILL OF MATERIAL

Bar	No.	Size	Length	Shape
h(E)	24	#8	16'-9"	—
h ₁ (E)	28	#8	12'-11"	—
p(E)	20	#7	25'-1"	—
s ₂ (E)	40	#4	11'-5"	□
s ₃ (E)	2	#4	12'-3"	□
u(E)	16	#6	10'-2"	∩
v ₁ (E)	98	#5	4'-4"	—
v ₂ (E)	22	#5	11'-6"	—
Structure Excavation		Cu. Yd.	213	
Concrete Structures		Cu. Yd.	24	
Concrete Encasement		Cu. Yd.	3	
Reinforcement Bars, Epoxy Coated		Pound	4,330	
Furnishing Steel Piles HP 12x53		Foot	672	
Driving Piles		Foot	672	
Test Pile		Each	1	
Steel HP 12x53				
Geocomposite Wall Drains		Sq. Yd.	50	

For details of Bar Splicers, see sheet 17 of 20.
For details of piles and Concrete Encasement, see sheet 16 of 20.

PILE DATA

Type: HP12x53
Nominal Required Bearing: 400 Kips
Factored Resistance Available: 200 Kips
Est. Length: 96 Feet/Pile
No. Production Piles: 7
No. Test Piles: 1

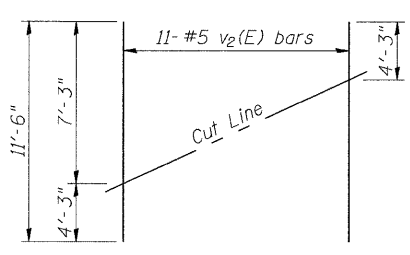

Order v₂(E) full length. Cut as shown and use remainder of bars in opposite face.

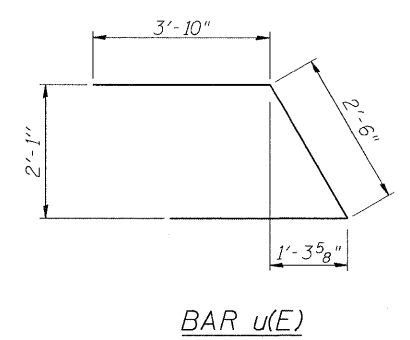
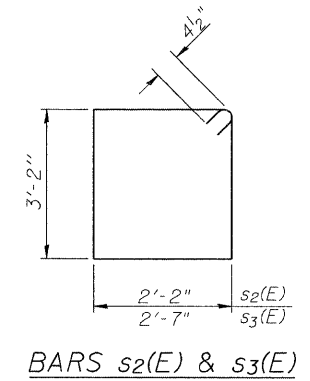

USER NAME = brianf	DESIGNED MJD	REVISED -
PLOT SCALE =	CHECKED AJS	REVISED -
PLOT DATE = 8/11/2011	DRAWN B/JF	REVISED -
	CHECKED RRD	REVISED -

F.A.P. RTE.	SECTION	COUNTY	TOTAL SHEETS	SHEET NO.
585	128 BR	HENRY	106	59
CONTRACT NO. 64C20			ILLINOIS FED. AID PROJECT	

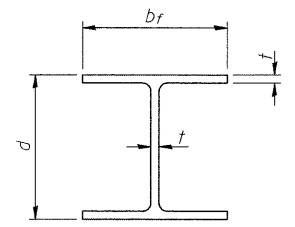

STEEL PILE TABLE

Designation	Depth d	Flange width bf	Web and Flange thickness t	Encasement diameter A
HP 14x117	14 1/4"	14 7/8"	1 3/16"	30"
x102	14"	14 3/4"	1 1/16"	30"
x89	13 7/8"	14 3/4"	5/8"	30"
x73	13 5/8"	14 5/8"	1/2"	30"
HP 12x84	12 1/4"	12 1/4"	1 1/16"	24"
x74	12 1/8"	12 1/4"	5/8"	24"
x63	12"	12 3/8"	1/2"	24"
x53	11 3/4"	12"	7/16"	24"
HP 10x57	10"	10 1/4"	9/16"	24"
x42	9 3/4"	10 1/8"	7/16"	24"
HP 8x36	8"	8 1/8"	7/16"	18"

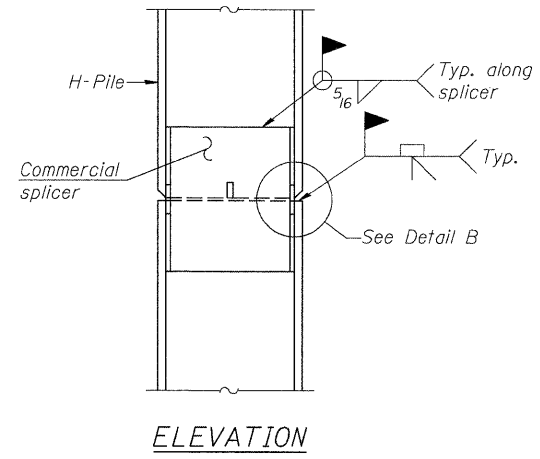

ELEVATION

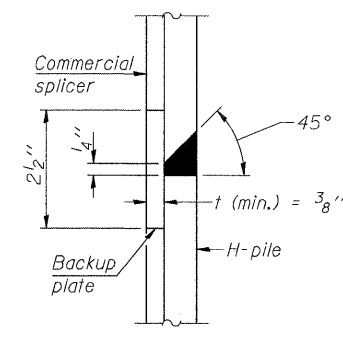

DETAIL "B"

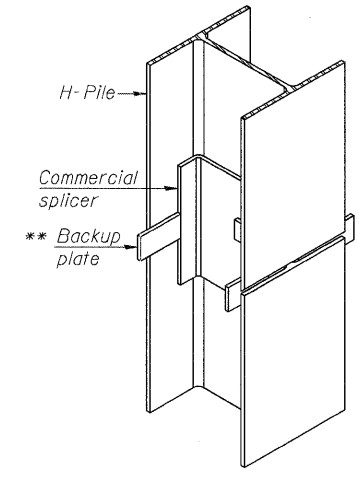

ISOMETRIC VIEW

WELDED COMMERCIAL SPLICE

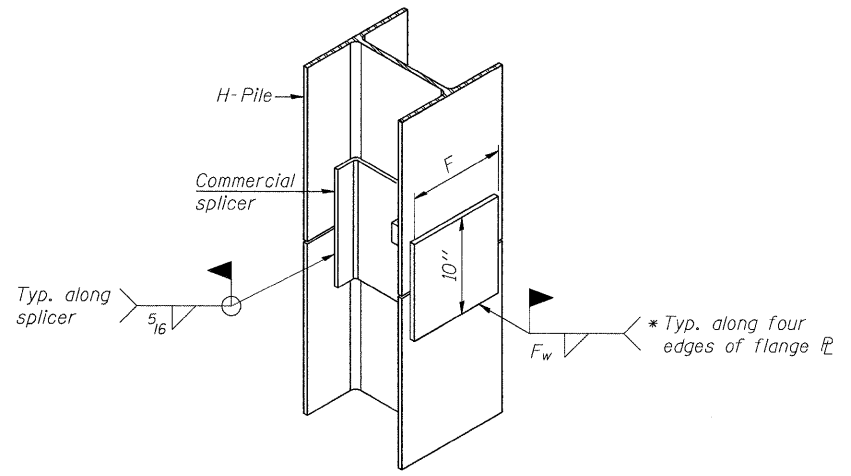

ISOMETRIC VIEW

WELDED COMMERCIAL SPLICE ALTERNATE

- * Interrupt welds 1/4" from end of web and/or each flange.
- ** Remove portions of backup plates that extend outside the flanges.
- *** Weld size per pile shoe manufacturer (5/16" min.).

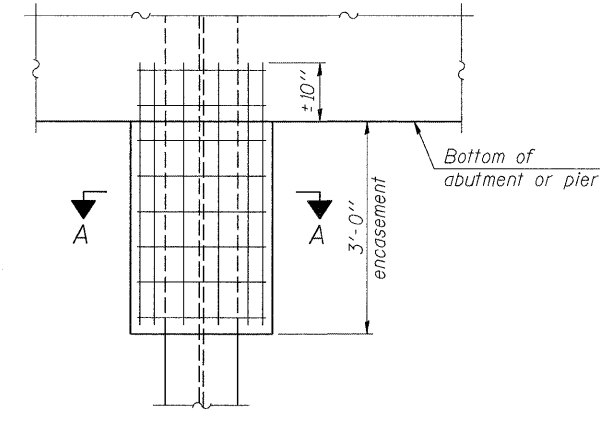

ELEVATION

PILE ENCASEMENT

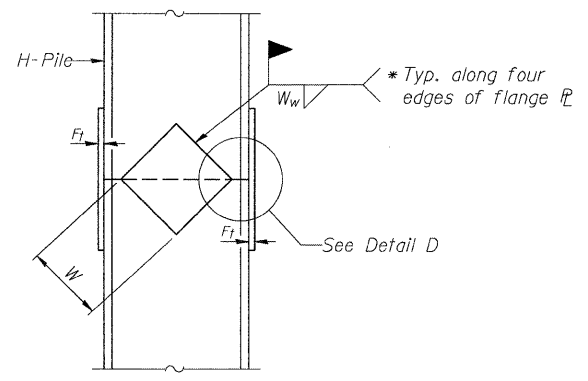

ELEVATION

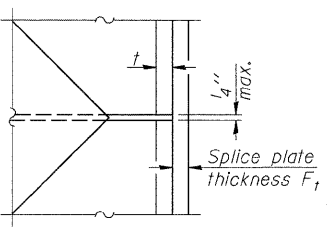

DETAIL D

WELDED PLATE FIELD SPLICE

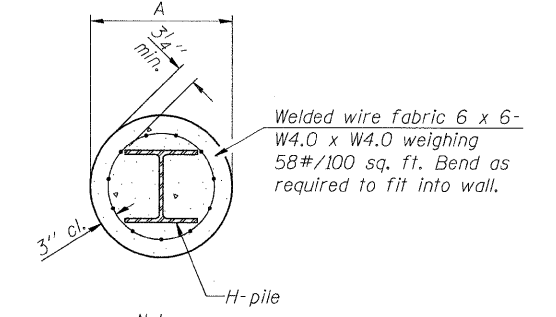

SECTION A-A

Note:
Forms for encasement may be omitted when soil conditions permit.

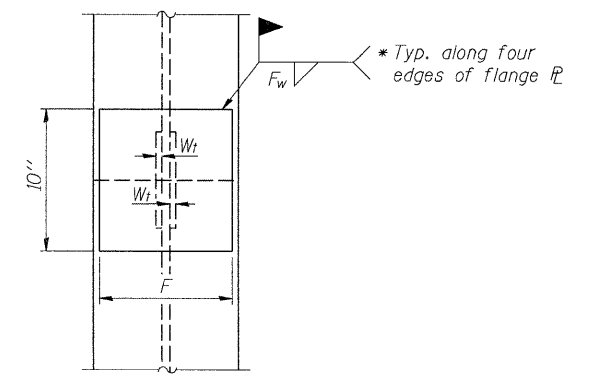

END VIEW

Designation	F	Ft	Fw	W	Wt	Ww
HP 14x117	12 1/2"	1"	7/8"	7 3/4"	5 8/8"	1/2"
x102	12 1/2"	7/8"	3/4"	7 3/4"	5 8/8"	1/2"
x89	12 1/2"	3/4"	1 1/16"	7 3/4"	5 8/8"	1/2"
x73	12 1/2"	5/8"	9/16"	7 3/4"	5 8/8"	1/2"
HP 12x84	10"	7/8"	1 1/16"	6 1/2"	5 8/8"	1/2"
x74	10"	7/8"	1 1/16"	6 1/2"	5 8/8"	1/2"
x63	10"	5/8"	1/2"	6 1/2"	1/2"	3/8"
x53	10"	5/8"	1/2"	6 1/2"	1/2"	3/8"
HP 10x57	8"	3/4"	9/16"	5 1/4"	1/2"	3/8"
x42	8"	5/8"	9/16"	5 1/4"	1/2"	3/8"
HP 8x36	7"	5/8"	7/16"	4 1/4"	1/2"	3/8"

Note:
The steel H-piles shall be according to AASHTO M270 Grade 50.

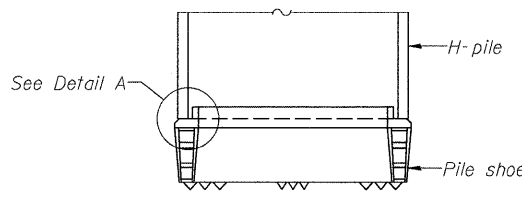

ELEVATION

DETAIL A

H-PILE SHOE ATTACHMENT

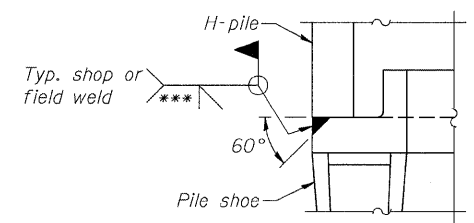

F-HP 7-1-10

FILE NAME = s:\p\63009-6395\6346\027\micro\final\plans\structural\0370174-64C20-016-PILE.dgn

1170 SOUTH HOUBOLT ROAD JOLIET, ILLINOIS 60431 (815) 744-4200	USER NAME = brianf	DESIGNED MJD	REVISED -	STATE OF ILLINOIS DEPARTMENT OF TRANSPORTATION	HP PILE DETAILS STRUCTURE NO. 037-0174		F.A.P. RTE. 585	SECTION 128 BR	COUNTY HENRY	TOTAL SHEETS 106	SHEET NO. 60	
	PLOT SCALE =	DRAWN BJF	REVISED -				CONTRACT NO. 64C20					
	PLOT DATE = 7/19/2011	CHECKED RRD	REVISED -				ILLINOIS FED. AID PROJECT					

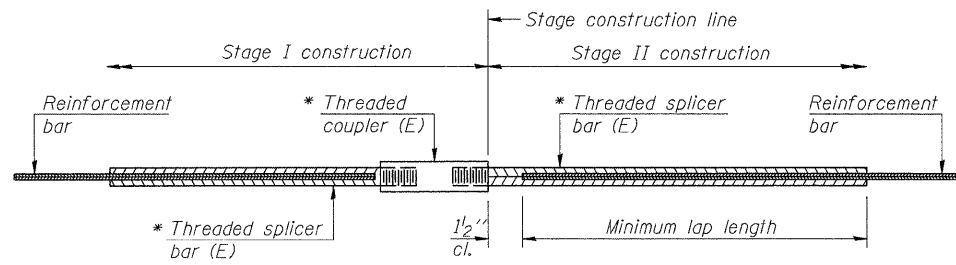

STANDARD BAR SPLICER ASSEMBLY

Minimum Lap Lengths					
Bar size to be spliced	Table 1	Table 2	Table 3	Table 4	Table 5
3, 4	1'-5"	1'-11"	2'-1"	2'-4"	2'-3"
5	1'-9"	2'-5"	2'-7"	2'-11"	2'-10"
6	2'-1"	2'-11"	3'-1"	3'-6"	3'-4"
7	2'-9"	3'-10"	4'-2"	4'-8"	4'-6"
8	3'-8"	5'-1"	5'-5"	6'-2"	5'-10"
9	4'-7"	6'-5"	6'-10"	7'-9"	7'-5"

- Table 1: Black bar, 0.8 Class C
- Table 2: Black bar, Top bar lap, 0.8 Class C
- Table 3: Epoxy bar, 0.8 Class C
- Table 4: Epoxy bar, Top bar lap, 0.8 Class C
- Table 5: Epoxy bar, Top bar lap, Class B

Threaded splicer bar length = min. lap length + 1 1/2" + thread length

* Epoxy not required on Bar Splicer Assembly components used in conjunction with black bars.

Location	Bar size	No. assemblies required	Table for minimum lap length
Deck	#5	652	Table 3
Diaphragms	#6	16	Table 3
West Abutment	#7	10	Table 4
East Abutment	#7	10	Table 4
West Approach Slab	#4	71	Table 3
West Approach Slab	#5	40	Table 3
East Approach Slab	#4	71	Table 3
East Approach Slab	#5	40	Table 3

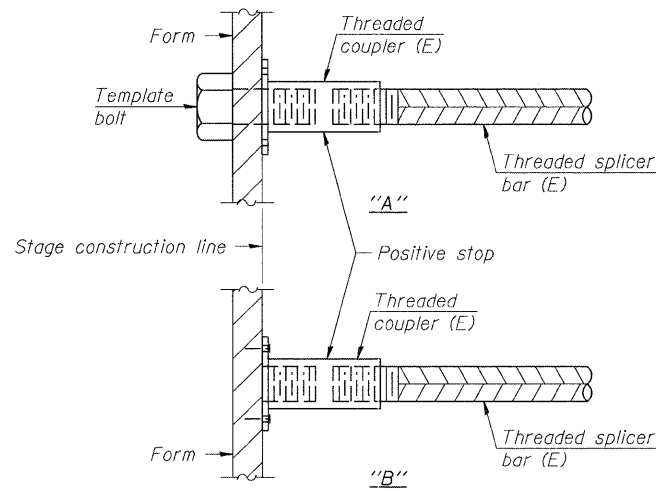

INSTALLATION AND SETTING METHODS

- "A" : Set bar splicer assembly by means of a template bolt.
- "B" : Set bar splicer assembly by nailing to wood forms or cementing to steel forms.
- (E) : Indicates epoxy coating.

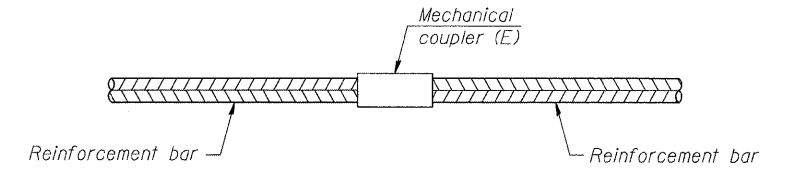

STANDARD MECHANICAL SPLICER

Location	Bar size	No. assemblies required

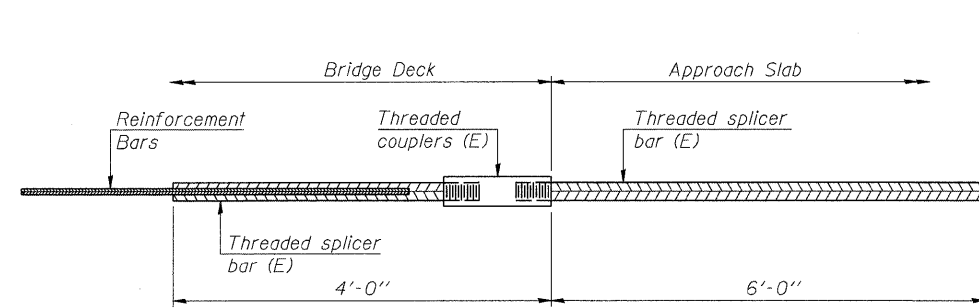

BAR SPLICER ASSEMBLY FOR #5 BAR ON INTEGRAL OR SEMI-INTEGRAL ABUTMENTS

No. required = 94

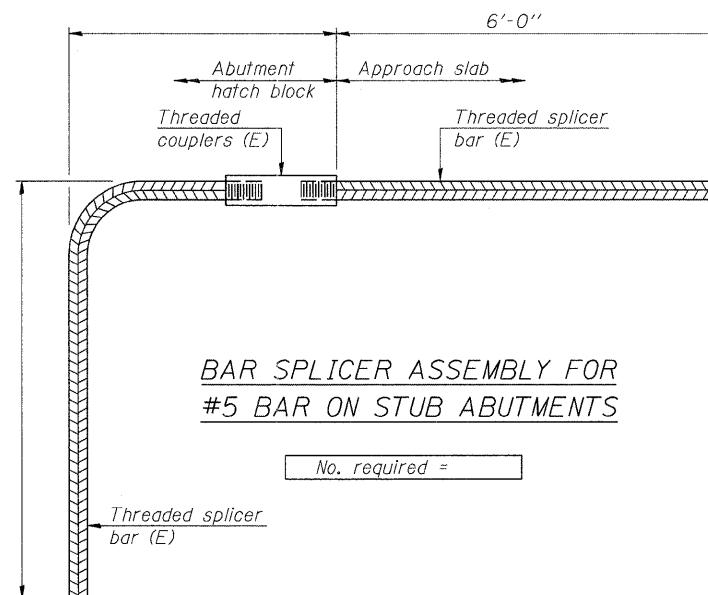

BAR SPLICER ASSEMBLY FOR #5 BAR ON STUB ABUTMENTS

No. required =

NOTES

- Splicer bars shall be deformed with threaded ends and have a minimum 60 ksi yield strength.
- All reinforcement shall be lapped and tied to the splicer bars.
- Bar splicer assemblies shall be epoxy coated according to the requirements for reinforcement bars. See Section 508 of the Standard Specifications.
- See special provision for Mechanical Splicers.
- See approved list of bar splicer assemblies and mechanical splicers for alternatives.

FILE NAME = s:\jpl\6300-6399\6346\027\meca\T\pl\struct\0370174-64C20-017-SPLICE.dgn

BSD-1

7-1-10

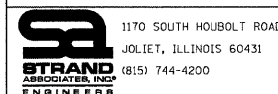

USER NAME = brionf	DESIGNED MJD	REVISED -
PLOT SCALE =	CHECKED AJS	REVISED -
PLOT DATE = 7/19/2011	DRAWN BJF	REVISED -
	CHECKED RRD	REVISED -

**STATE OF ILLINOIS
DEPARTMENT OF TRANSPORTATION**

**BAR SPLICER ASSEMBLY AND MECHANICAL SPLICER DETAILS
STRUCTURE NO. 037-0174**

SHEET NO. 17 OF 20 SHEETS

F.A.P. RTE.	SECTION	COUNTY	TOTAL SHEETS	SHEET NO.
585	128 BR	HENRY	106	61
				CONTRACT NO. 64C20
ILLINOIS FED. AID PROJECT				



Illinois Department of Transportation
Division of Highways
IDOT

SOIL BORING LOG

Page 1 of 3

Date 4/28/06

ROUTE FAP 585 DESCRIPTION P92-049-06 IL 92 bridge over Main Union Ditch, 1.0 m. W. of IL 78, 3/4 m. W. of Countryman Road LOGGED BY W. Garza

SECTION 128 BR LOCATION Yorktown Twp. - 7 SE, SEC., TWP. 18N, RNG. 5E

COUNTY Henry DRILLING METHOD Hollow Stem Auger HAMMER TYPE B-53 Diedrich Automatic

STRUCT. NO.	DEPTH	BLOWS	UCS	MOIST	Surface Water Elev.	DEPTH	BLOWS	UCS	MOIST
Station 470+54	(ft)	(/6")	(tsf)	(%)	ft	(ft)	(/6")	(tsf)	(%)
BORING NO. B-1					88.6				
Station 471+05					87.4				
Offset 14.00ft Lt CL									
Ground Surface Elev. 99.4									
MEDIUM dark brown SILTY CLAY LOAM			0.5 P	43	MEDIUM gray clean medium coarse SAND				
					77.90				
STIFF dark brown LOAM	96.90	1	1.1 P	37	Wash MEDIUM gray clean medium coarse SAND				
		4			75.40				
	94.90	4							
LOOSE brown fine SAND									
		1							
	92.90	3							
		4			72.90				
VERY LOOSE/LOOSE brown fine SAND									
		2							
	90.40	2			70.40				
		2							
VERY LOOSE/LOOSE brown fine SAND									
		3							
	87.90	2			67.90				
		2							
LOOSE gray/tan fine SAND									
		2							
	85.40	3			65.40				
		4							
LOOSE brown fine SAND									
		2							
	82.90	2			62.90				
		3							
LOOSE gray fine SAND									
		1							
	80.40	2			60.40				
		4							

The Unconfined Compressive Strength (UCS) Failure Mode is indicated by (B-Bulge, S-Shear, P-Penetrometer)
The SPT (N value) is the sum of the last two blow values in each sampling zone (AASHTO T206)
BBS, from 137 (Rev. 8-99)

Note:
In the above logs, groundwater elevations are at the time the boring was taken.



Illinois Department of Transportation
Division of Highways
IDOT

SOIL BORING LOG

Page 2 of 3

Date 4/28/06

ROUTE FAP 585 DESCRIPTION P92-049-06 IL 92 bridge over Main Union Ditch, 1.0 m. W. of IL 78, 3/4 m. W. of Countryman Road LOGGED BY W. Garza

SECTION 128 BR LOCATION Yorktown Twp. - 7 SE, SEC., TWP. 18N, RNG. 5E

COUNTY Henry DRILLING METHOD Hollow Stem Auger HAMMER TYPE B-53 Diedrich Automatic

STRUCT. NO.	DEPTH	BLOWS	UCS	MOIST	Surface Water Elev.	DEPTH	BLOWS	UCS	MOIST
Station 470+54	(ft)	(/6")	(tsf)	(%)	ft	(ft)	(/6")	(tsf)	(%)
BORING NO. B-1					88.6				
Station 471+05					87.4				
Offset 14.00ft Lt CL									
Ground Surface Elev. 99.4									
Wash MEDIUM gray fine SAND with CLAY lens					STIFF gray SILTY CLAY				
		10							
	57.40	11			37.90				
		7							
Wash STIFF gray CLAY LOAM					Wash STIFF gray SILTY CLAY				
		4							
	55.40	5	1.2 B	26					
		7			35.40				
VERY STIFF gray CLAY LOAM					VERY STIFF gray CLAY LOAM				
		2							
	52.90	5	2.7 B	28					
		6			32.90				
Wash VERY STIFF gray CLAY LOAM					Wash VERY STIFF gray CLAY LOAM with fine SAND lens				
		3							
	50.40	4	2.1 S	25					
		6			29.90				
VERY STIFF gray CLAY LOAM					MEDIUM gray fine SAND				
		1							
	47.90	4	2.3 B	29					
		6			27.90				
Wash STIFF gray CLAY					MEDIUM gray fine SAND				
		4							
	45.40	6	1.8 S	30					
		7			25.40				
VERY STIFF gray CLAY					LOOSE gray fine SAND				
		5							
	42.90	8	3.1 B	30					
		8			22.90				
Wash VERY STIFF gray CLAY					Wash MEDIUM gray fine SAND				
		7							
	40.40	8	2.4 S	31					
		9			20.40				

The Unconfined Compressive Strength (UCS) Failure Mode is indicated by (B-Bulge, S-Shear, P-Penetrometer)
The SPT (N value) is the sum of the last two blow values in each sampling zone (AASHTO T206)
BBS, from 137 (Rev. 8-99)

Soil Boring Log Station and Elevation Shift
Boring Log Station + 15513.67' = Plan Set Station
Boring Log Elevation + 512.02' = Plan Set Elevation

FILE NAME = s:\p1\6308-6398\6346\027\microsof\p1\p1\037\0174-6420-01B-SBL.dgn



1170 SOUTH HOBOLT ROAD
JOLIET, ILLINOIS 60431
(815) 744-4200

USER NAME = b1erif	DESIGNED MJD	REVISED -
CHECKED AJS	DRAWN B/JF	REVISED -
PLOT SCALE =	CHECKED RRD	REVISED -
PLOT DATE = 7/19/2011		

STATE OF ILLINOIS
DEPARTMENT OF TRANSPORTATION

SOIL BORING LOG (SHEET 1 OF 3)
STRUCTURE NO. 037-0174

SHEET NO. 18 OF 20 SHEETS

F.A.P. RTE.	SECTION	COUNTY	TOTAL SHEETS	SHEET NO.
585	128 BR	HENRY	106	62
CONTRACT NO. 64C20				
ILLINOIS FED. AID PROJECT				



Illinois Department of Transportation
Division of Highways
IDOT

SOIL BORING LOG

Page 3 of 3

Date 4/28/06

ROUTE FAP 585 DESCRIPTION 1.0 m. W. of IL 78, 3/4 m. W. of Countryman Road LOGGED BY W. Garza

SECTION 128 BR LOCATION Yorktown Twp. - 7 SE. SEC., TWP. 18N, RNG. 5E

COUNTY Henry DRILLING METHOD Hollow Stem Auger HAMMER TYPE B-53 Diedrich Automatic

STRUCT. NO. Station	DEPTH H	BLOW S	UCS Qu	MOIST T	Surface Water Elev.	Stream Bed Elev.	Groundwater Elev.:	First Encounter	Upon Completion	After
470+54	(ft)	(/6")	(tsf)	(%)	ft	ft	ft	ft	ft	ft
Wash MEDIUM/DENSE gray fine SAND	1	10			88.6	87.4				
	17.90	20								
Wash VERY DENSE gray fine SAND	11	36			86.4					
	15.40	64								
End of Boring	-85									
	-90									
	-95									
	-100									

The Unconfined Compressive Strength (UCS) Failure Mode is indicated by (B-Bulge, S-Shear, P-Penetrometer)
The SPT (N value) is the sum of the last two blow values in each sampling zone (AASHTO T206)
BBS, from 137 (Rev. 8-99)

Note:
In the above logs, groundwater elevations are at the time the boring was taken.



Illinois Department of Transportation
Division of Highways
IDOT

SOIL BORING LOG

Page 1 of 3

Date 5/4/06

ROUTE FAP 585 DESCRIPTION 1.0 m. W. of IL 78 on IL 92 LOGGED BY W. Garza

SECTION 128 BR LOCATION Yorktown Twp. - 7 SE. SEC., TWP. 18N, RNG. 5E

COUNTY Henry DRILLING METHOD Hollow Stem Auger HAMMER TYPE B-53 Diedrich Automatic

STRUCT. NO. Station	DEPTH H	BLOW S	UCS Qu	MOIST T	Surface Water Elev.	Stream Bed Elev.	Groundwater Elev.:	First Encounter	Upon Completion	After
470+54	(ft)	(/6")	(tsf)	(%)	ft	ft	ft	ft	ft	ft
MEDIUM dark brown SILTY CLAY LOAM with 15% ORGANICS			0.8 P	41	88.6	87.4				
	96.90									
STIFF dark brown SILTY CLAY LOAM		2 3 5	1.8 P	33						
	95.40									
MEDIUM gray/brown LOAM with 13% ORGANICS		1 2 2	0.8 P	46						
	92.90									
MEDIUM dark brown LOAM with 14% ORGANICS		1 1 1	0.6 P	51						
	90.40									
STIFF dark gray SILTY LOAM with 13% ORGANICS		1 1 2	1.0 B	49						
	87.40									
LOOSE gray fine SAND		2 2 3								
	85.40									
LOOSE gray fine SAND		1 2 4								
	82.90									
MEDIUM gray clean medium SAND		5 8 12								
	80.40									
	-20									

The Unconfined Compressive Strength (UCS) Failure Mode is indicated by (B-Bulge, S-Shear, P-Penetrometer)
The SPT (N value) is the sum of the last two blow values in each sampling zone (AASHTO T206)
BBS, from 137 (Rev. 8-99)

Soil Boring Log Station and Elevation Shift
Boring Log Station + 1513.67' = Plan Set Station
Boring Log Elevation + 512.02' = Plan Set Elevation

FILE NAME = s:\p1\63009-63995\6346\027\microso\funnel\plans\structural\0378174-64c20-018-58L.dgn

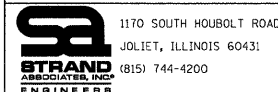

1170 SOUTH HOUBOLT ROAD JOLIET, ILLINOIS 60431 (815) 744-4200	USER NAME = brianf	DESIGNED MJD	REVISED -
	PLOT SCALE =	CHECKED AJS	REVISED -
	PLOT DATE = 7/19/2011	DRAWN B/JF	REVISED -
		CHECKED RRD	REVISED -

STATE OF ILLINOIS
DEPARTMENT OF TRANSPORTATION

SOIL BORING LOG (SHEET 2 OF 3)
STRUCTURE NO. 037-0174

SHEET NO. 19 OF 20 SHEETS

F.A.P. RTE.	SECTION	COUNTY	TOTAL SHEETS	SHEET NO.
585	128 BR	HENRY	106	63
				CONTRACT NO. 64C20
ILLINOIS FED. AID PROJECT				



SOIL BORING LOG

ROUTE FAP 585 DESCRIPTION P92-049-06 IL 92 bridge over Main Union Ditch, 1.0 m. W. of IL 78 on IL 92 LOGGED BY W. Garza
 SECTION 128 BR LOCATION Yorktown Twp. - 7 SE, SEC. , TWP. 18N, RNG. 5E
 COUNTY Henry DRILLING METHOD Hollow Stem Auger HAMMER TYPE B-53 Diedrich Automatic

STRUCT. NO.	D	B	U	M	Surface Water Elev.	D	B	U	M
Station	E	L	C	O	Stream Bed Elev.	E	L	C	O
BORING NO.	P	W	S	I	Groundwater Elev.:	P	W	S	I
Station	T	H	Qu	S	First Encounter	H	S	Qu	T
Offset					Upon Completion				
Ground Surface Elev.	(ft)	(/6")	(tsf)	(%)	After	(ft)	(/6")	(tsf)	(%)
					Hrs.				
Wash VERY STIFF gray SILTY CLAY	3				88.6	4			
	5	2.3		25	87.4	5	2.7		31
	7	B				8	S		
	3					3			
Wash MEDIUM gray SILTY LOAM	3		0.5	28		5	2.7		33
	6	P				6	S		
	2					5			
MEDIUM gray SILTY LOAM	5	0.5		29		7	2.5		31
	9	P				10	S		
	3					3			
STIFF gray SILTY CLAY	7	1.3		19		4	2.1		32
	8	B				5	B		
	2					3			
VERY STIFF gray CLAY LOAM	4	2.2		30		5	1.8		29
	5	S				6	P		
	4					3			
VERY STIFF gray CLAY LOAM	4	2.7		30		13			
	7	B				14			
	4					3			
Wash STIFF gray SILTY CLAY	6	1.6		30		4			
	8	P				8			
	4					1			
Wash VERY STIFF gray CLAY	7	3.7		29		1			
	8	B				9			

The Unconfined Compressive Strength (UCS) Failure Mode is indicated by (B-Bulge, S-Shear, P-Penetrometer)
 The SPT (N value) is the sum of the last two blow values in each sampling zone (AASHTO T206)
 BBS, from 137 (Rev. 8-99)

Note:
 In the above logs, groundwater elevations are at the time the boring was taken.



SOIL BORING LOG

ROUTE FAP 585 DESCRIPTION P92-049-06 IL 92 bridge over Main Union Ditch, 1.0 m. W. of IL 78 on IL 92 LOGGED BY W. Garza
 SECTION 128 BR LOCATION Yorktown Twp. - 7 SE, SEC. , TWP. 18N, RNG. 5E
 COUNTY Henry DRILLING METHOD Hollow Stem Auger HAMMER TYPE B-53 Diedrich Automatic

STRUCT. NO.	D	B	U	M	Surface Water Elev.	D	B	U	M
Station	E	L	C	O	Stream Bed Elev.	E	L	C	O
BORING NO.	P	W	S	I	Groundwater Elev.:	P	W	S	I
Station	T	H	Qu	S	First Encounter	H	S	Qu	T
Offset					Upon Completion				
Ground Surface Elev.	(ft)	(/6")	(tsf)	(%)	After	(ft)	(/6")	(tsf)	(%)
					Hrs.				
Wash VERY DENSE gray fine SAND					88.6	12			
					87.4	30			
						61			
End of Boring									

The Unconfined Compressive Strength (UCS) Failure Mode is indicated by (B-Bulge, S-Shear, P-Penetrometer)
 The SPT (N value) is the sum of the last two blow values in each sampling zone (AASHTO T206)
 BBS, from 137 (Rev. 8-99)

Soil Boring Log Station and Elevation Shift
 Boring Log Station + 15513.67' = Plan Set Station
 Boring Log Elevation + 512.02' = Plan Set Elevation

 1170 SOUTH HOBOLT ROAD JOLIET, ILLINOIS 60431 (815) 744-4200	USER NAME = <u>brianf</u>	DESIGNED <u>MJD</u>	REVISED -	STATE OF ILLINOIS DEPARTMENT OF TRANSPORTATION	SOIL BORING LOG (SHEET 3 OF 3) STRUCTURE NO. 037-0174	F.A.P. RTE. <u>585</u>	SECTION <u>128 BR</u>	COUNTY <u>HENRY</u>	TOTAL SHEETS <u>106</u>	SHEET NO. <u>64</u>
	PLOT SCALE =	DRAWN <u>BJF</u>	REVISED -			CONTRACT NO. <u>64C20</u>				
	PLOT DATE = <u>7/19/2011</u>	CHECKED <u>RRD</u>	REVISED -			ILLINOIS FED. AID PROJECT				
	SHEET NO. 20 OF 20 SHEETS									

FILE NAME = s:\j\63009-6399-6346-027\microa\lin\plena\structural\0370174-64C20-018-58L.dgn

GENERAL NOTES

Reinforcement bars shall conform to the requirements of ASTM A 706 Gr 60. See Special Provisions.
Reinforcement bars designated (E) shall be epoxy coated.

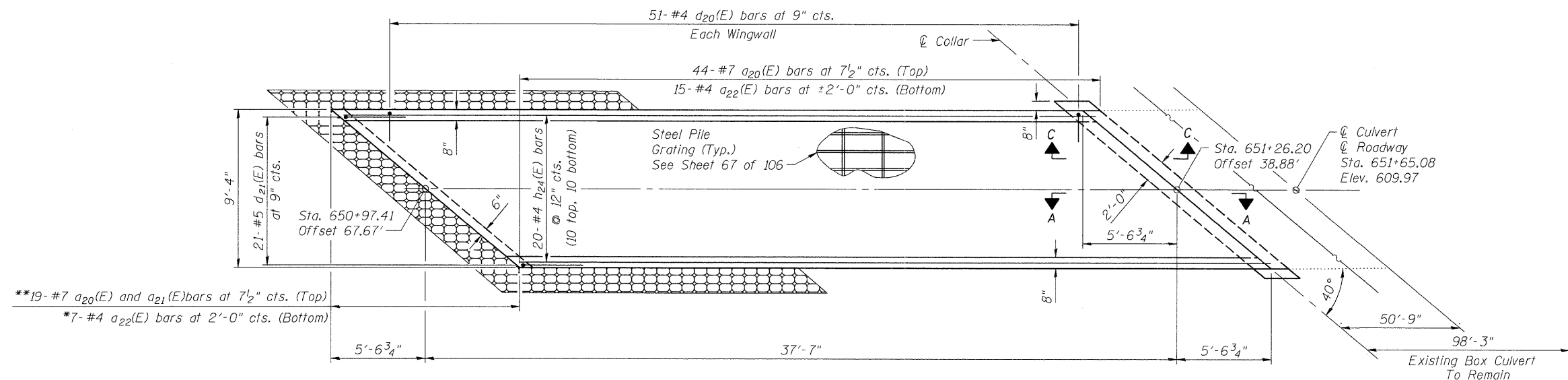

PLAN - BOTTOM SLAB SOUTH WINGWALL

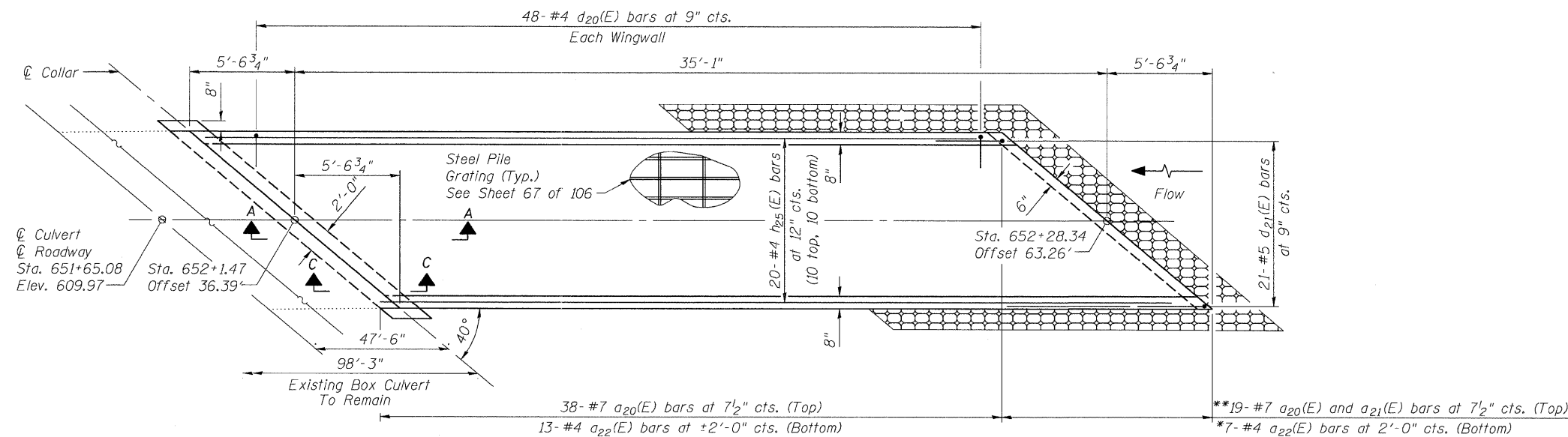

PLAN - BOTTOM SLAB NORTH WINGWALL

* Order a22(E) bars full length. Cut to fit skew and use remainder of bars at opposite end

** Order a20(E) bars full length. Cut to fit skew and use remainder of bars at opposite end. Lap with a21(E) bars. Rotate at corner to fit.

See sheet 66 of 106 for Section A-A and Section C-C.

FILE NAME = s:\j\6300-6399\6346\02\inprova\1\plans\structural\0370174-64C20-019-CB01.dgn

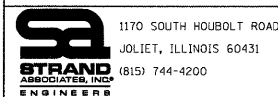

USER NAME = brianf	DESIGNED MJD	REVISED -
PLLOT SCALE =	CHECKED AJS	REVISED -
PLLOT DATE = 7/19/2011	DRAWN BJF	REVISED -
	CHECKED MJD	REVISED -

**STATE OF ILLINOIS
DEPARTMENT OF TRANSPORTATION**

**WINGWALL DETAILS (1 OF 2)
STRUCTURE NO. 037-1184**

SHEET NO. 1 OF 3 SHEETS

F.A.P. RTE.	SECTION	COUNTY	TOTAL SHEETS	SHEET NO.
585	128 BR	HENRY	106	65
				CONTRACT NO. 64C20

ILLINOIS FED. AID PROJECT

FILE NAME = s:\proj\63302-6395\6346\027\micro\structure\0370174-64C20-019-CB01.dgn

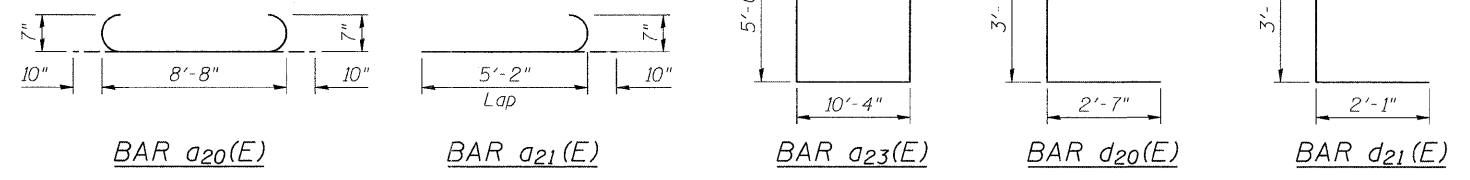
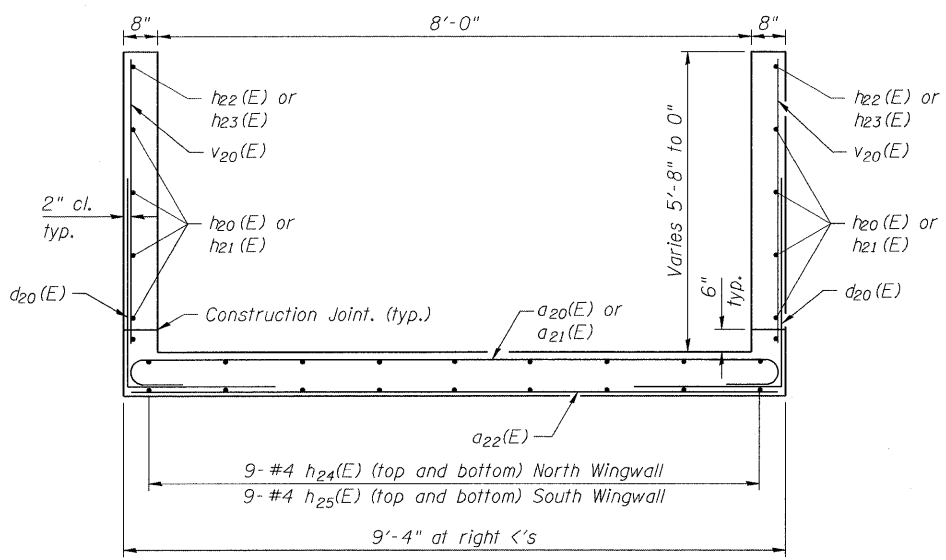
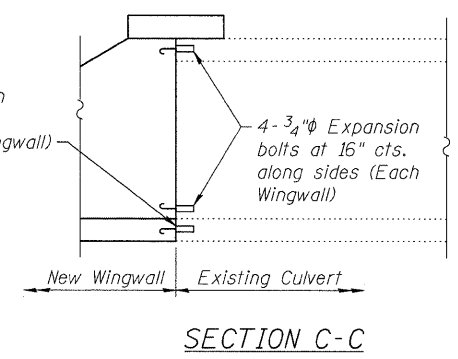
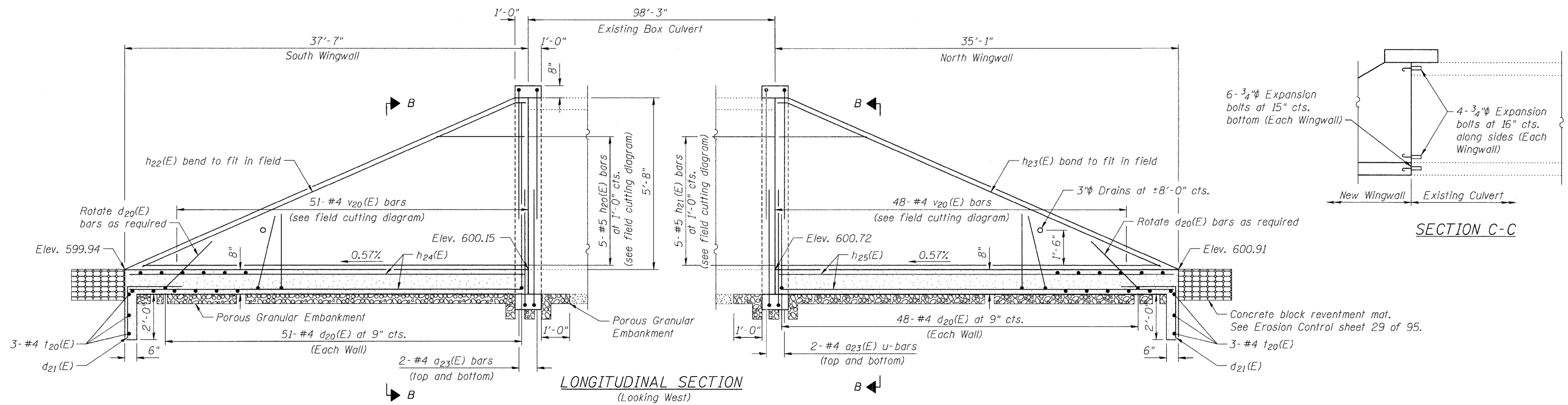

MIN. BAR LAP
 #4 bars = 2'-7"
 #5 bars = 3'-3"

BILL OF MATERIAL

Bar	No.	Size	Length	Shape
a20(E)	120	#7	10'-4"	U
a21(E)	76	#7	6'-0"	U
a22(E)	42	#4	9'-0"	—
a23(E)	8	#4	20'-4"	U
d20(E)	198	#4	6'-2"	L
d21(E)	42	#5	5'-8"	L
h20(E)	5	#5	41'-1"	—
h21(E)	5	#5	38'-5"	—
h22(E)	1	#5	35'-8"	—
h23(E)	1	#5	33'-4"	—
h24(E)	20	#4	37'-3"	—
h25(E)	20	#4	34'-9"	—
h26(E)	84	#4	1'-6"	—
l20(E)	6	#4	11'-9"	—
v20(E)	99	#4	8'-7"	—
Concrete Collar			Cu. Yd.	3.7
Removal of Existing Structure No. 1			Each	1
Box Culvert End Sections, Culvert No. 1			Each	2
Reinforcement Bars, Epoxy Coated			Pound	7,120

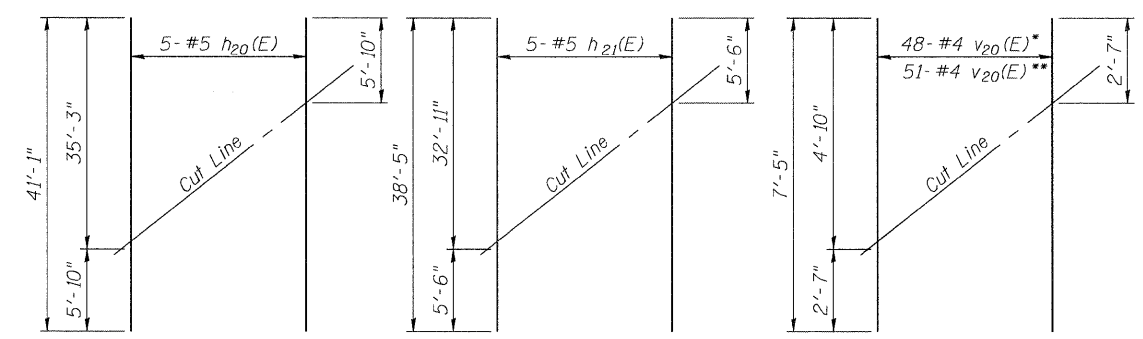
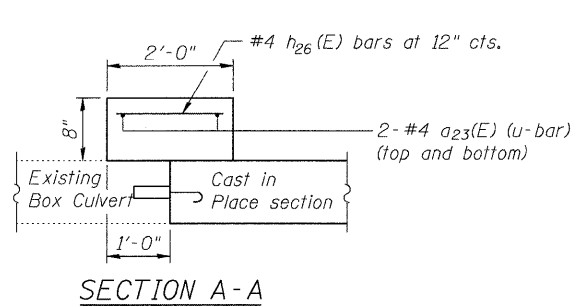

North Wall Field Cut Diagram
 Order h20(E) full length. Cut as shown and use remainder of bars on shorter side.

South Wall Field Cut Diagram
 Order h21(E) full length. Cut as shown and use remainder of bars on shorter side.

North and South Wall Field Cut Diagram
 Order v20(E) full length. Cut as shown and use remainder of bars on shorter side.

*North Wall
 **South Wall



USER NAME = brianf	DESIGNED MJD	REVISED -
PLOT SCALE *	CHECKED AJS	REVISED -
PLOT DATE = 7/19/2011	DRAWN B/JF	REVISED -
	CHECKED RRD	REVISED -

**STATE OF ILLINOIS
 DEPARTMENT OF TRANSPORTATION**

**WINGWALL DETAILS (2 OF 2)
 STRUCTURE NO. 037-1184**
 SHEET NO. 2 OF 3 SHEETS

F.A.P. RTE. 585	SECTION 128 BR	COUNTY HENRY	TOTAL SHEETS 106	SHEET NO. 66
			CONTRACT NO. 64C20	
ILLINOIS FED. AID PROJECT				

GENERAL NOTES

Length and number of steel pipes shall be determined by the Contractor except as shown. All steel pipe shall be standard weight (Sch. 40) unless otherwise noted.
 All components of the Steel Pipe Grate System shall be galvanized according to the requirements of AASHTO M 111 or M 232 as applicable.
 Fabrication of the Steel Pipe Grate System shall conform to the requirements in Section 505 of the Standard Specifications unless noted otherwise.
 Structural steel shapes and plates shall conform to the requirements of Article 1006.04 of the Standard Specifications. Steel pipes shall conform to the requirements of ASTM A 53 (Type E or S), Grade B.
 Anchor rods shall conform to the requirements of ASTM F1554, Grade 105. Anchor rods shall be drilled and epoxy grouted according to the requirements of Section 584 of the Standard Specifications. The chemical adhesive system shall be capable of achieving a minimum proof load of 5000 pounds and an ultimate shear capacity of 8000 pounds per anchor.
 Bolts and thru bolts shall conform to the requirements of Article 1006.08 of the Standard Specifications except threaded rods conforming to the requirements of ASTM F1554, Grade 105 may be used for the thru bolts.
 The minimum edge distance from the center of a hole to the free edge of a structural shape or plate shall be 1/2" unless noted otherwise.
 Bolts and anchor rods shall be snug tightened by a few impacts of an impact wrench or the full force of a worker using an ordinary spud wrench.
 All cost associated with fabricating, furnishing, and installing the Steel Pipe Grate System shall be included in the contract unit price for Box Culvert End Sections, Culvert No. 1. Each cell shall have a Steel Pipe Grate system.
 The contractor shall contact Illinois Department of Transportation, Region 2, District 2 Bridge Office at (815) 284-5393 to collect the name plate for the box culvert (S.N. 037-1184). Installation of the name plate shall be included in the cost of end sections.

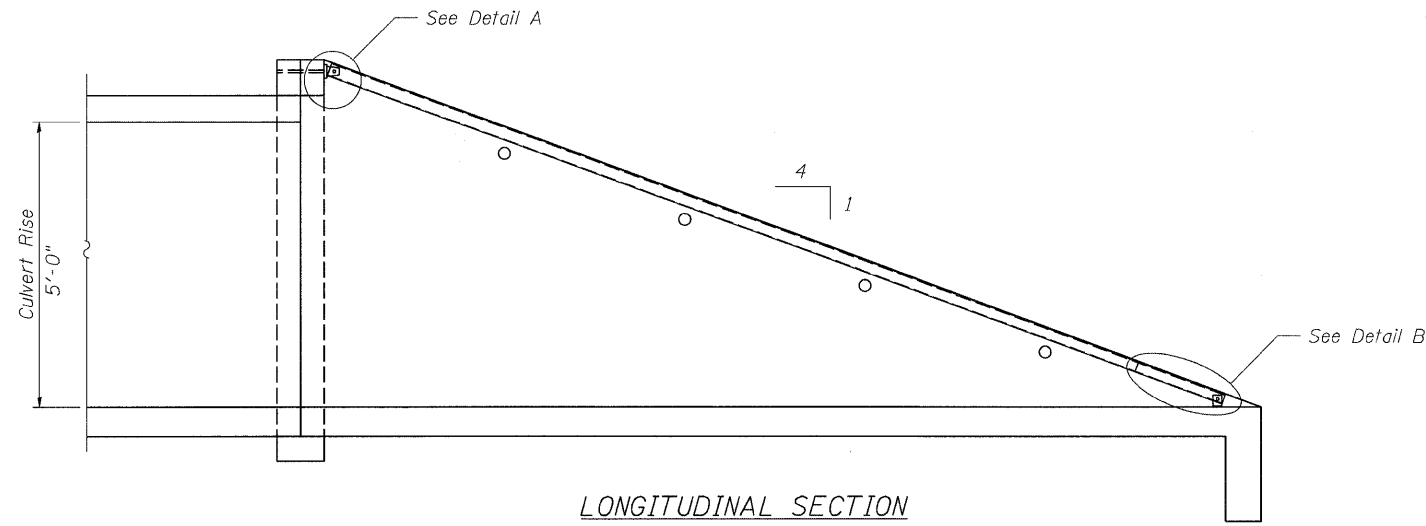

LONGITUDINAL SECTION

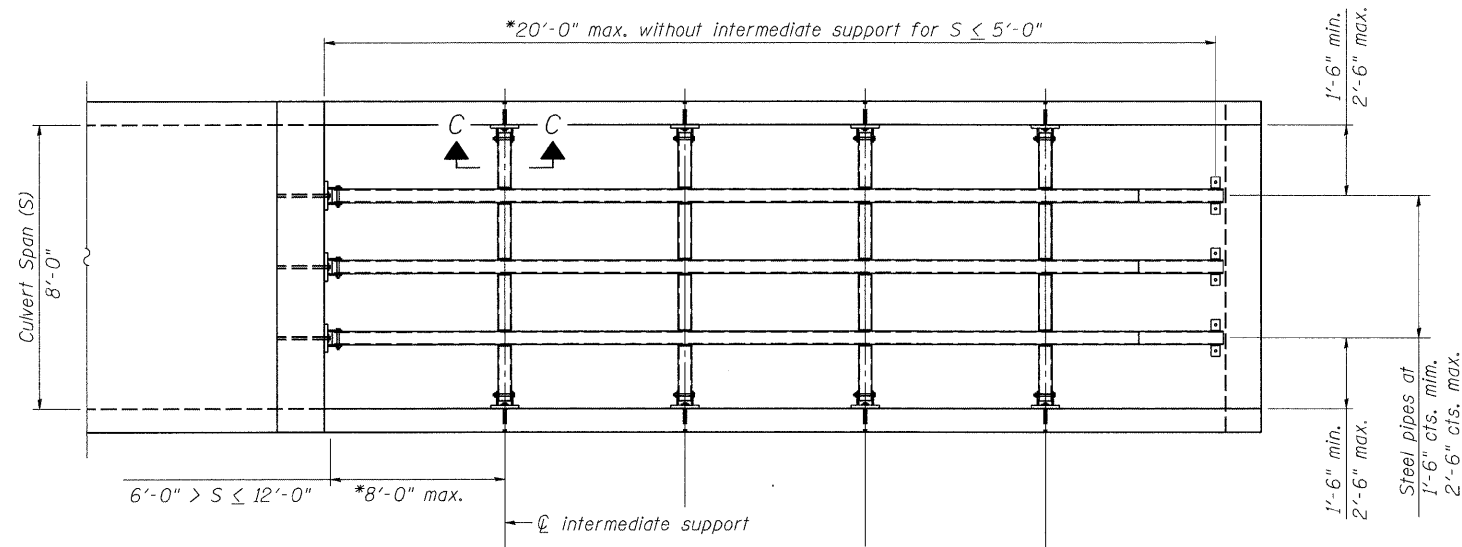

PLAN VIEW

*Measured along embankment slope.

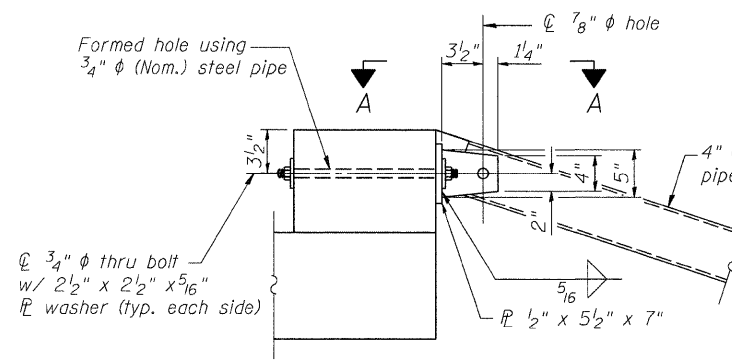

DETAIL A

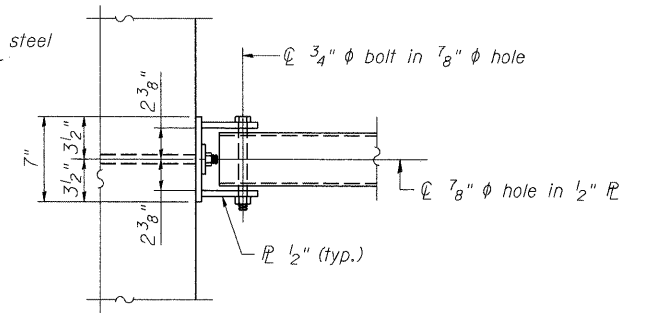

SECTION A-A

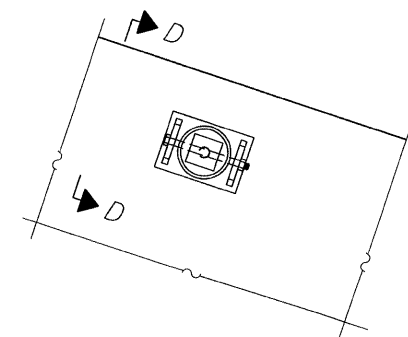

SECTION C-C

(See Detail A for dimensions and details not shown.)

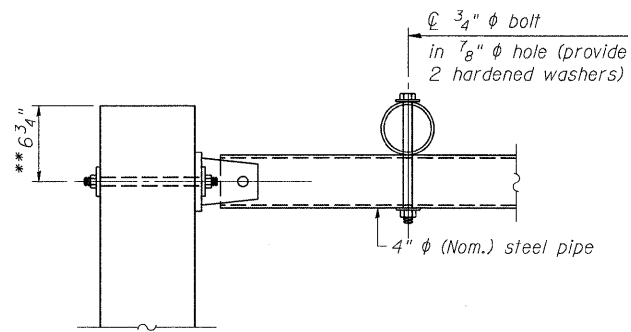

SECTION D-D

** Measured perpendicular to top of culvert wall. In addition, formed hole shall be located a minimum of 6" measured horizontally from any vertical joints necessary for construction of the culvert end section.

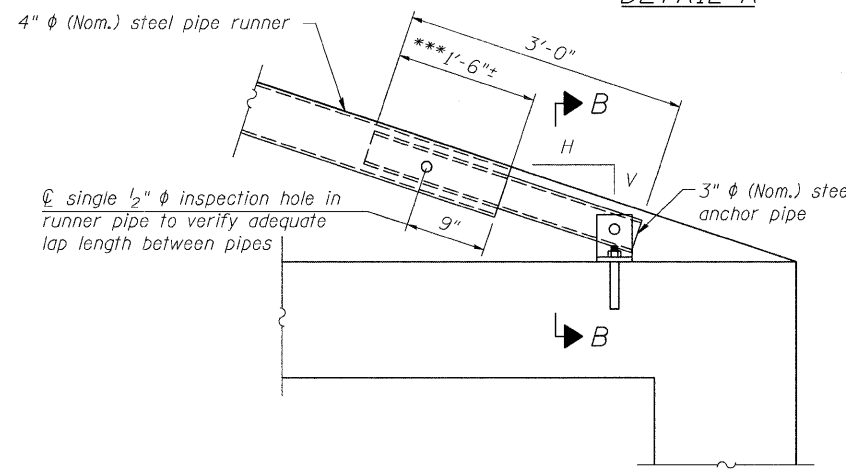

DETAIL B

*** The lap length between pipes may be adjusted in the field to accommodate construction tolerances but shall not be less than 9".

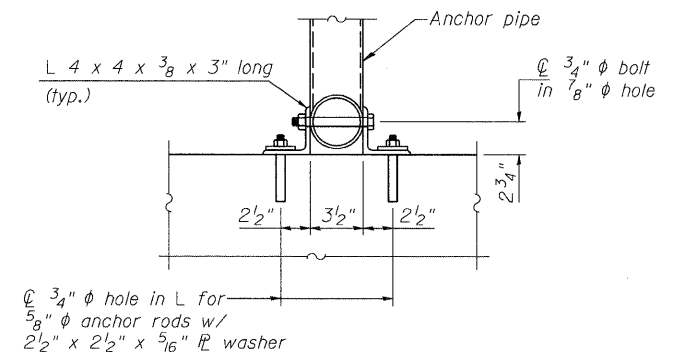

SECTION B-B

FILE NAME = s:\j\163309--6393\6346\027\micrca\final\plans\structural\0370174-64C20-020-PIPE.dgn

2-16-11

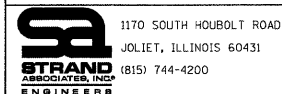

1170 SOUTH HOUBOLT ROAD
 JOLIET, ILLINOIS 60431
 (815) 744-4200

USER NAME = brianf	DESIGNED MJD	REVISED -
PLOT SCALE =	CHECKED AJS	REVISED -
PLOT DATE = 7/19/2011	DRAWN B/JF	REVISED -
	CHECKED RRD	REVISED -

**STATE OF ILLINOIS
 DEPARTMENT OF TRANSPORTATION**

**STEEL PIPE GRATE SYSTEM
 STRUCTURE NO. 037-1184**

SHEET NO. 3 OF 3 SHEETS

F.A.P. RTE. 585	SECTION 128 BR	COUNTY HENRY	TOTAL SHEETS 106	SHEET NO. 67
				CONTRACT NO. 64C20
ILLINOIS FED. AID PROJECT				

DETAIL OF HOT-MIX ASPHALT SHOULDER AT GUARD RAIL

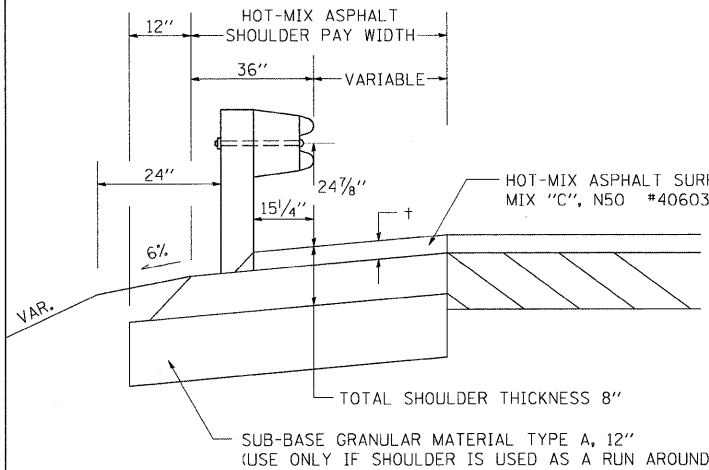

† = SEE TYPICAL SECTIONS FOR THICKNESS

GENERAL NOTES

THE TOP LIFT SHALL NOT BE PLACED BEHIND THE GUARDRAIL POSTS. WHEN PLACING THE TOP LIFT THE RAIL MUST BE REMOVED FROM THE POSTS. THE POST SHALL NOT BE REMOVED.

THE HEIGHT OF THE GUARD RAIL SHALL BE SET 24 7/8" FROM THE FINISHED SURFACE.

THE HOT-MIX ASPHALT SHOULDER SHALL BE CONSTRUCTED IN ACCORDANCE WITH SECTION 482 EXCEPT THE TOP LIFT SHALL BE HOT-MIX ASPHALT SURFACE COURSE, MIXTURE C, N50. THE WORK WILL BE PAID FOR AT THE CONTRACT UNIT PRICE PER TON FOR HOT-MIX ASPHALT SURFACE COURSE, MIXTURE "C", N50 AND SQUARE YARD FOR HOT-MIX ASPHALT SHOULDERS OF THE THICKNESS SPECIFIED. THE REMOVAL & REINSTALLATION OF THE GUARDRAIL WILL BE INCLUDED IN THE COST OF THE HOT-MIX ASPHALT SURFACE COURSE, MIXTURE C, N50.

REVISED - 6-06-11

DETAIL OF HOT-MIX ASPHALT SHOULDER AT GUARD RAIL 23.4

HOT-MIX ASPHALT SHOULDER

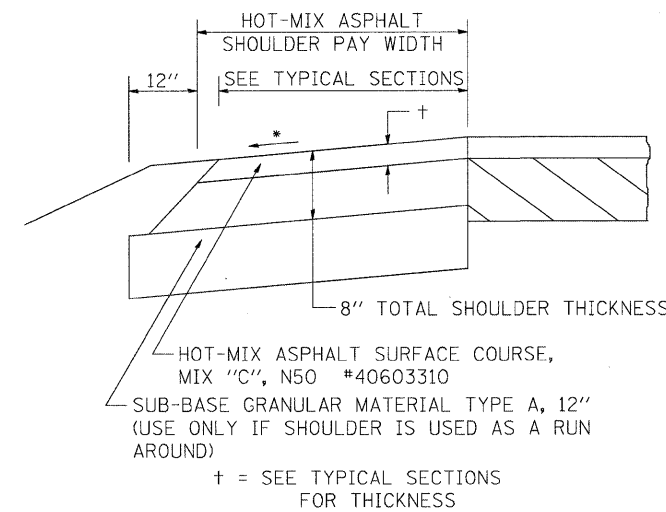

GENERAL NOTES

THE HOT-MIX ASPHALT SHOULDER SHALL BE CONSTRUCTED IN ACCORDANCE WITH SECTION 482 EXCEPT THE TOP LIFT SHALL BE HOT-MIX ASPHALT SURFACE COURSE, MIX "C", N50 #40603310. THE WORK WILL BE PAID FOR AT THE CONTRACT UNIT PRICE PER TON FOR HOT-MIX ASPHALT SURFACE COURSE, MIX "C", N50 #40603310 AND SQUARE YARD FOR HOT-MIX ASPHALT SHOULDERS OF THE THICKNESS SPECIFIED.

USE HOT-MIX ASPHALT SURFACE COURSE, MIX "C", N50 #40603310. WHEN RESURFACING EXISTING HOT-MIX ASPHALT SHOULDERS, THE THICKNESS IS SHOWN ON THE TYPICAL SECTIONS. THIS WORK WILL BE PAID FOR AT THE CONTRACT UNIT PRICE PER TON FOR HOT-MIX ASPHALT SURFACE COURSE, MIX "C", N50 #40603310.

REMOVAL OF MATERIAL FOR PLACEMENT OF THE HOT-MIX ASPHALT SHOULDER TO BE PAID FOR IN UNITS FOR EXCAVATING AND GRADING EXISTING SHOULDERS OR IN CUBIC YARDS FOR EARTH EXCAVATION OR EARTH EXCAVATION WIDENING.

* 4% WHEN MAINLINE IS ON TANGENT. FOR CROSS SLOPE ON SUPERELEVATION SECTION, SEE HIGHWAY STANDARD 482001 OR 482006.

REVISED - 6-06-11

HOT-MIX ASPHALT SHOULDER 23.4a

CONCRETE HEADWALLS FOR PIPE DRAINS

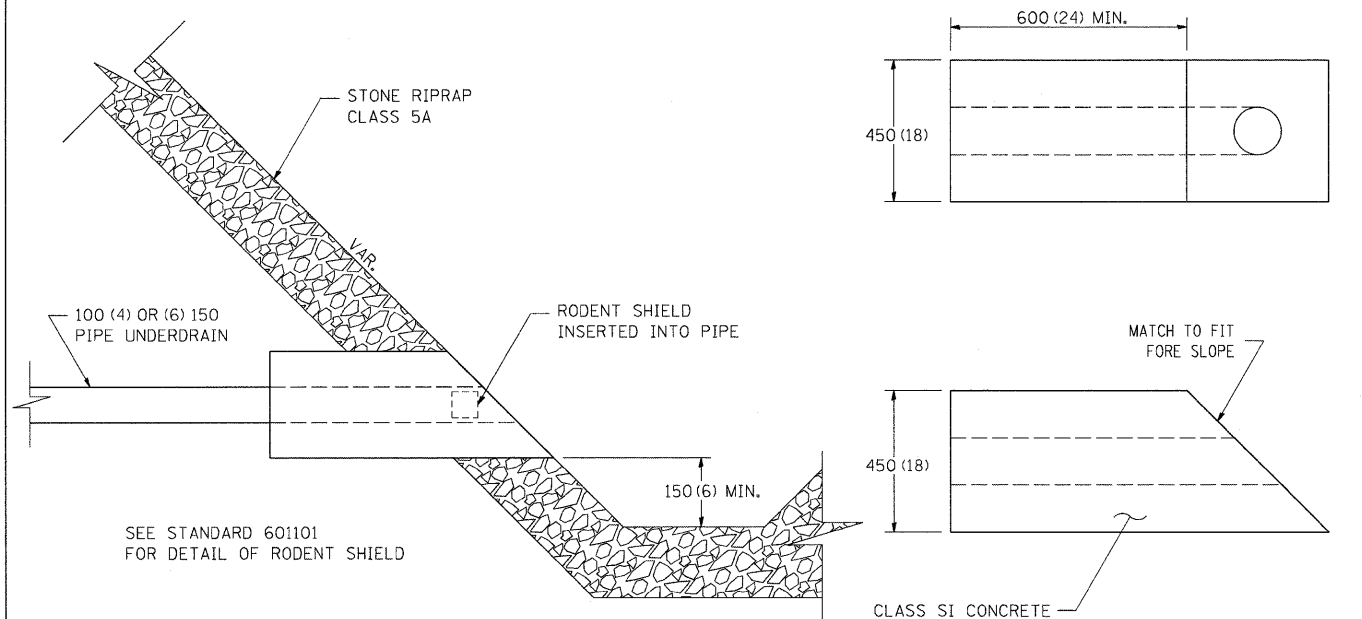

ALL DIMENSIONS ARE IN MILLIMETERS (INCHES) UNLESS OTHERWISE NOTED.

REVISED - 10-15-04

CONCRETE HEADWALLS FOR PIPE DRAINS 27.4

DELINEATOR AND POST ORIENTATION

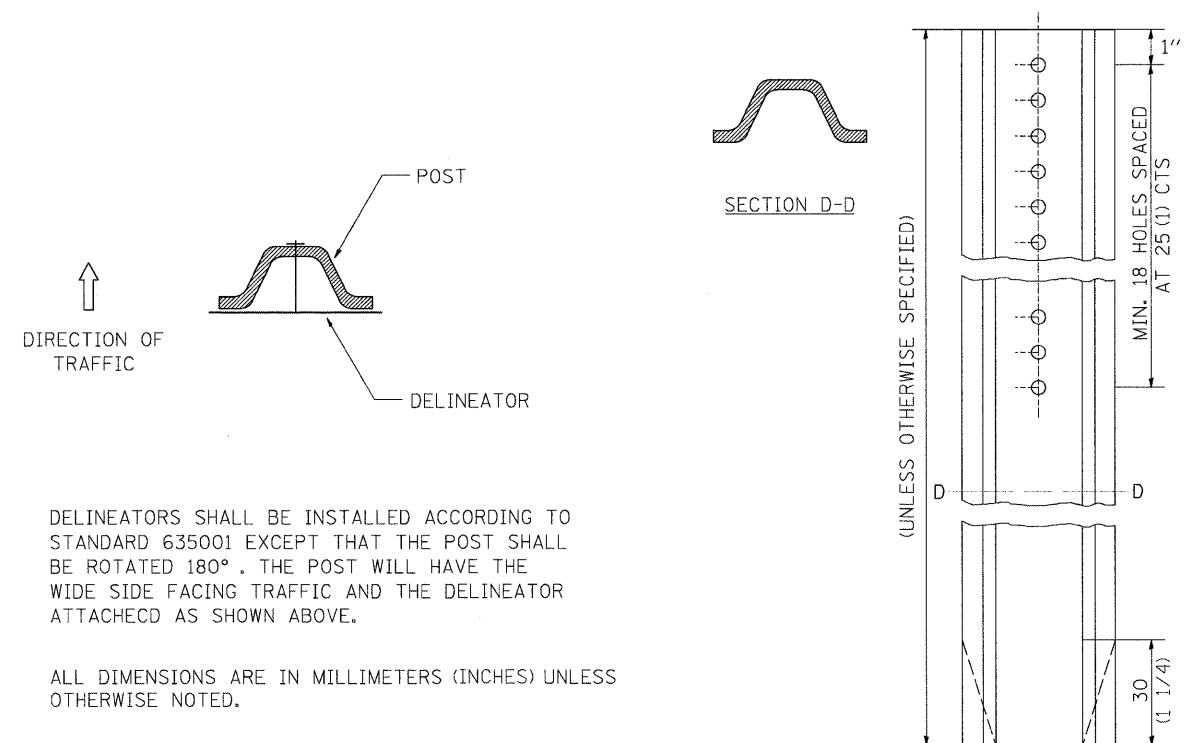

DELINEATORS SHALL BE INSTALLED ACCORDING TO STANDARD 635001 EXCEPT THAT THE POST SHALL BE ROTATED 180°. THE POST WILL HAVE THE WIDE SIDE FACING TRAFFIC AND THE DELINEATOR ATTACHED AS SHOWN ABOVE.

ALL DIMENSIONS ARE IN MILLIMETERS (INCHES) UNLESS OTHERWISE NOTED.

REVISED 11-01-07	REGION 2 / DISTRICT 2 STANDARD				F.A.P. RTE.	SECTION	COUNTY	TOTAL SHEETS	SHEET NO.
REVISED -					585	128 BR	HENRY	106	68
REVISED -					CONTRACT NO. 64C20				
REVISED -	SCALE: 1:0000' / IN.	SHEET NO.	OF	SHEETS	STA.	TO STA.	FED. ROAD DIST. NO. 2 ILLINOIS FED. AID PROJECT		

TYPICAL BENCHING ON EXISTING EMBANKMENT

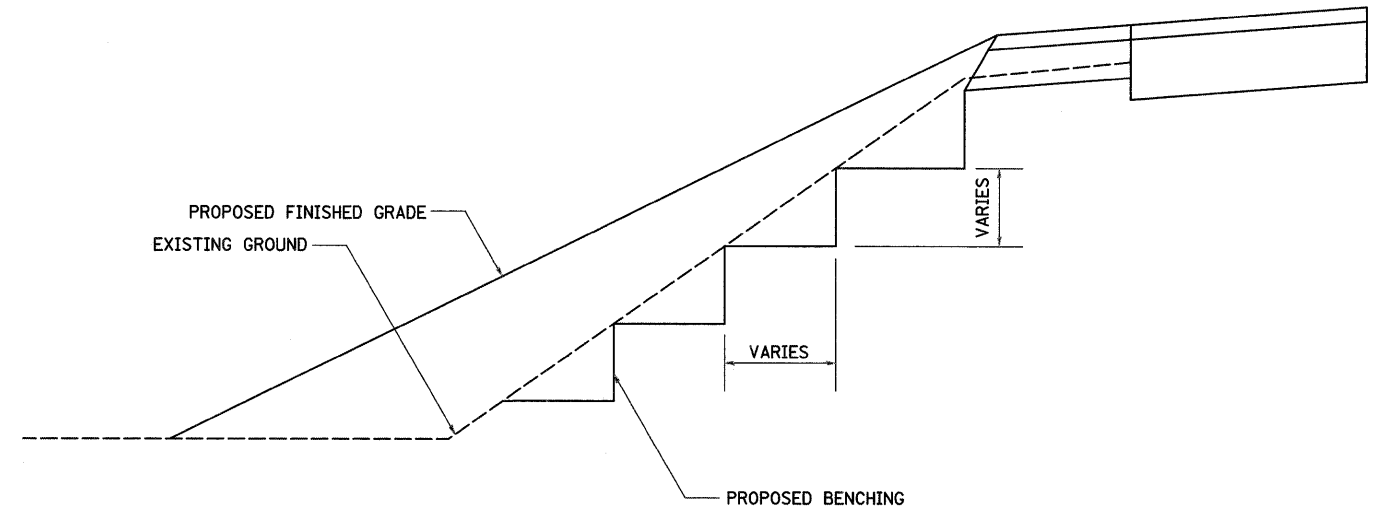

REVISED - 2-22-06

TYPICAL BENCHING ON EXISTING EMBANKMENT 50.4

LAND SECTION & REFERENCE MARKERS

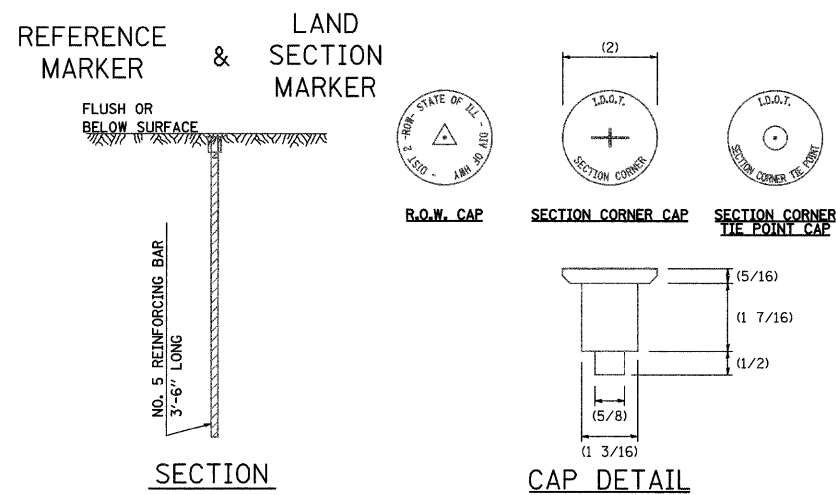

METHOD OF REFERENCING MARKERS

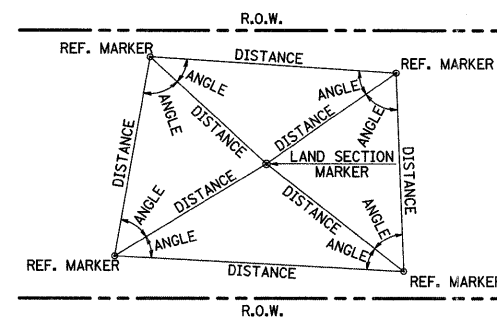

- USE INSTRUMENT TIES TO NEARBY LAND-MARKS (STEEPLES, TOWERS, SILOS, ETC...)
- IN CULTIVATED FIELDS, SET 28" OR MORE BELOW GROUND SURFACE.
- IN FENCE LINE OR PROTECTED AREA SET TOP AT GROUND LEVEL SO AS NOT TO BE DISTURBED BY MOWING.

ALL DIMENSIONS ARE IN INCHES UNLESS OTHERWISE NOTED.

METHOD OF REFERENCING POINTS
 REFERENCE MARKERS SHALL BE USED TO TIE IN PERMANENT LAND SECTION AND 1/4 SECTION CORNERS. WHERE LAND SECTION MARKERS FALL IN THE SHOULDERS OR GRAVEL SURFACES, THE TOP OF THE BAR SHALL BE KEPT 3" BELOW THE SURFACE. LAND SECTION MARKERS LOCATED IN TRAFFIC LANES SHALL BE REPLACED BY CORE DRILL AND RESETTING PIN.

ALUMINUM CAPS SHALL BE PLACED ON TOP OF THE REINFORCEMENT BAR. THERE ARE 3 TYPES OF CAPS, ONE FOR THE RIGHT-OF-WAY CORNERS, ONE FOR THE SECTION CORNERS AND ONE FOR THE SECTION CORNER TIE POINTS. THE CAPS WILL BE SUPPLIED BY THE SURVEYOR WHO IS RESPONSIBLE FOR MONUMENTING CORNERS.

REVISED - 03-05-10

LAND SECTION & REFERENCE MARKERS 63.4

STOP LINE SIGN FOR TEMPORARY SIGNALS

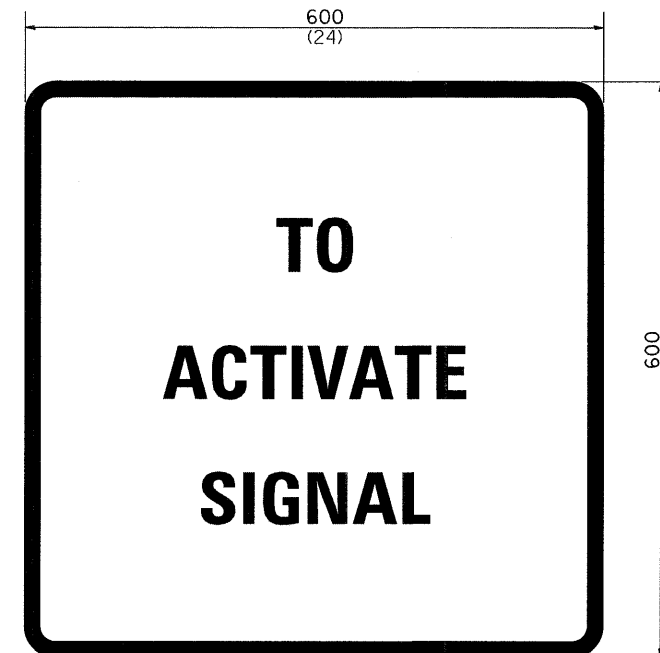

- SIZE: 600(24) x 600(24)
- 100(4) CAPITAL LETTERS - BLACK
- 13(1/2) BORDER - BLACK
- WHITE REFLECTIVE - TYPE AP HIGH INTENSITY PRISMATIC SHEETING

GENERAL NOTE:

THIS SIGN SHALL BE INSTALLED AT THE STOP LINE AS DIRECTED BY ENGINEER.

ALL DIMENSIONS ARE IN MILLIMETERS (INCHES) UNLESS OTHERWISE NOTED.

REVISED - 22-07	REGION 2 / DISTRICT 2 STANDARD				F.A.P. RTE.	SECTION	COUNTY	TOTAL SHEETS	SHEET NO.
REVISED -					585	128 BR	HENRY	106	69
REVISED -					CONTRACT NO. 64C20				
REVISED -	SCALE: 1.0000' / IN.	SHEET NO.	OF SHEETS	STA.	TO STA.		FED. ROAD DIST. NO. 2 ILLINOIS FED. AID PROJECT		

FIELD TILE JUNCTION VAULTS 600 (24) AND 900 (36) DIA.

INFORMATIONAL WARNING SIGN (FOR NARROW TRAVEL LANES)

FRAME & LID FOR
600 (24) VAULT

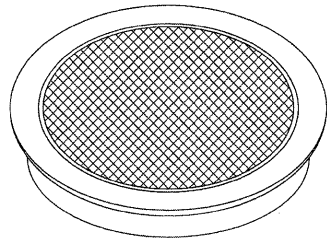

FRAME & LID FOR
900 (36) VAULT

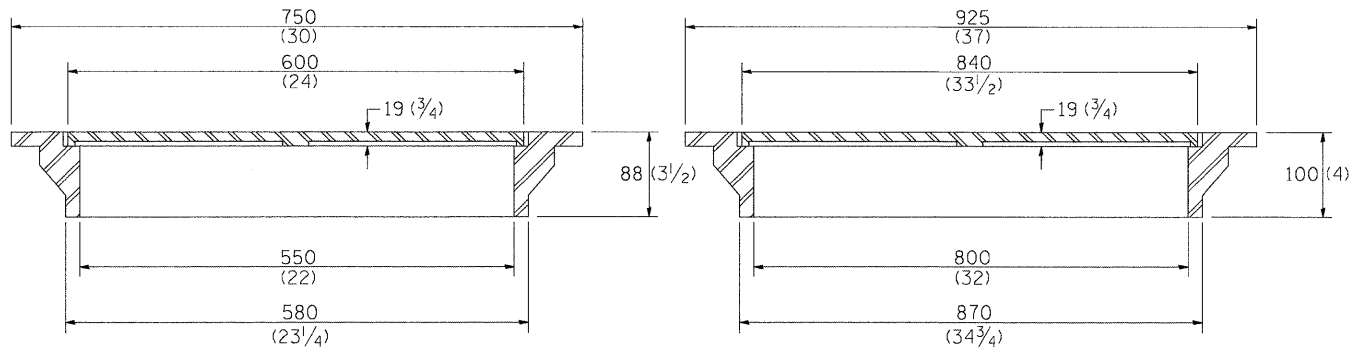

TOTAL WEIGHT: 66 Kg (146 lbs)

TOTAL WEIGHT: 127 Kg (280 lbs)

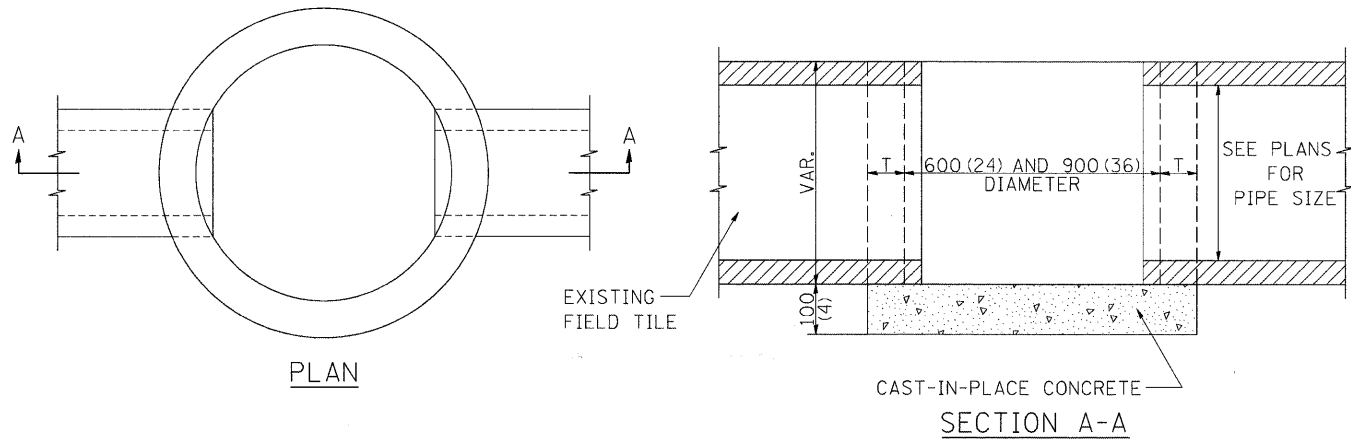

ALTERNATE MATERIALS FOR WALLS	T
BRICK MASONRY	200 (8)
CAST-IN-PLACE CONCRETE	150 (6)
CONCRETE MASONRY UNIT	125 (5)
PRECAST REINFORCED CONCRETE SECTION	75 (3)

NOTE: THE FRAME AND LID IS REQUIRED ON ALL JUNCTION VAULTS.

ALL DIMENSIONS ARE IN MILLIMETERS (INCHES) UNLESS OTHERWISE NOTED.

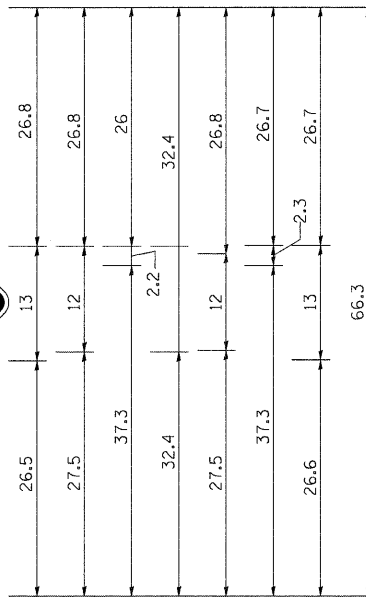
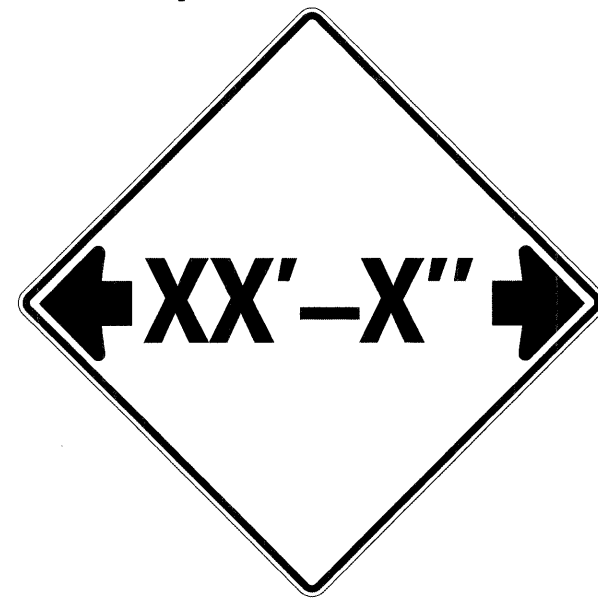
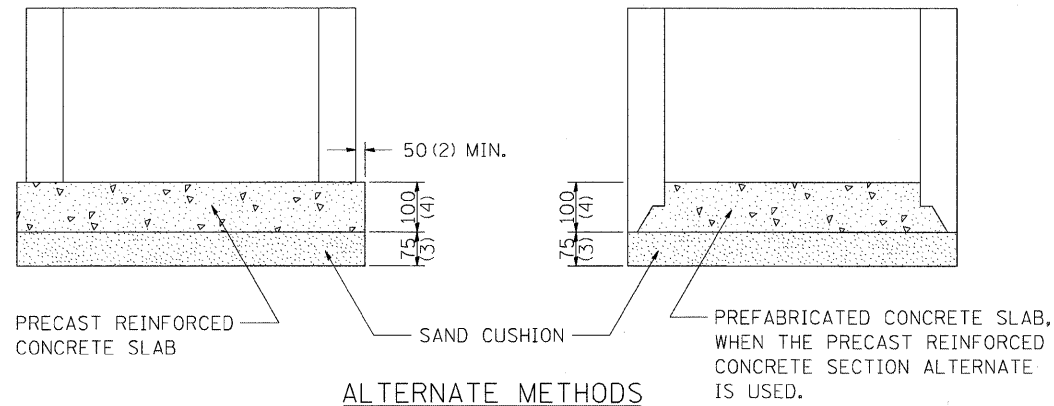

NOTES
W12-2 - Horizontal Clearance Sign
48.0" across sides, 1.9" Radius,
0.8" Border, 0.5" Indent, Black on
Orange; Standard Arrow Custom
10.4" X 8.1" 180° Black 11 Inch
D Series Lettering; Standard Arrow
Custom 10.4" X 8.1" 0°

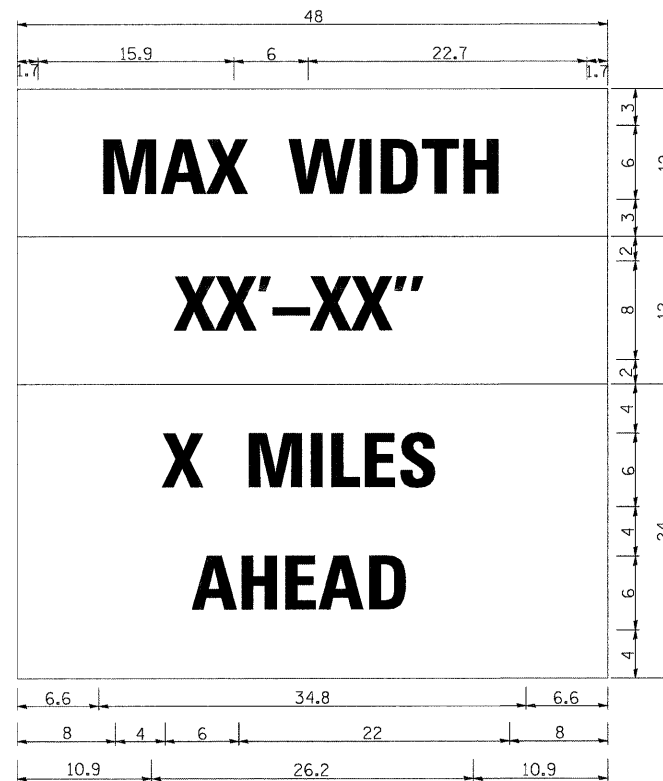
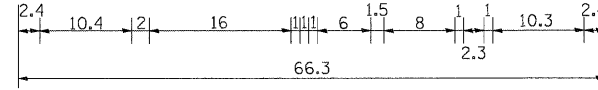

W12-I103 (Width Is 8D);
No border, Black on White;
[MAX WIDTH] D;

No border, Black on Orange;
[XX'-XX''] D;

No border, Black on White;
[X MILES] D; [AHEAD] D;

All work to furnish and install these signs shall be included in the cost of the Traffic Control Standards and shall not be paid for separately.

ALL DIMENSIONS ARE IN INCHES UNLESS OTHERWISE NOTED.

REVISED - 5-03-94

REVISED/REVISIONS	REGION 2 / DISTRICT 2 STANDARD	F.A.P. RTE.	SECTION	COUNTY	TOTAL SHEETS	SHEET NO.
REVISIONS		585	128 BR	HENRY	106	70
SCALE: 1:20000	SHEET NO. OF SHEETS	STA. TO STA.	CONTRACT NO. 64C20			
FED. ROAD DIST. NO. 2 ILLINOIS FED. AID PROJECT						

WITNESS MARKER FOR PERMANENT SURVEY MARKERS, TYPE II

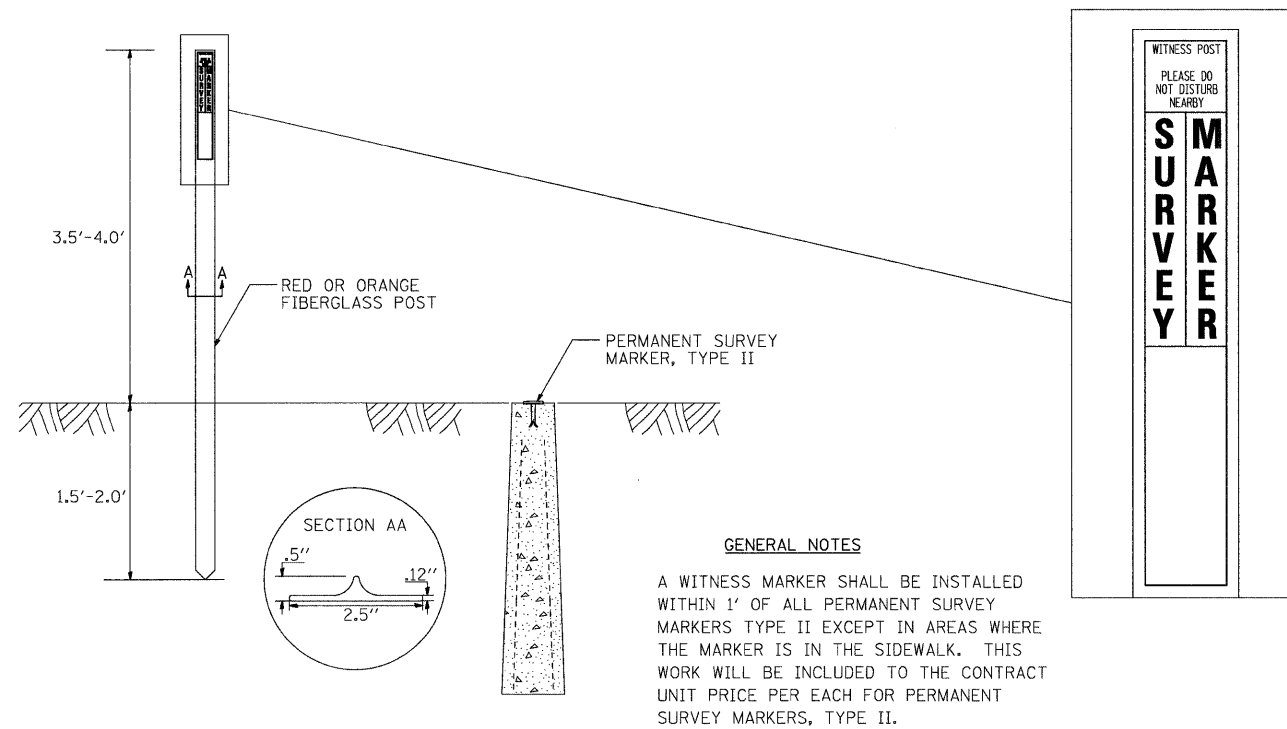

PERMANENT SURVEY MARKERS, TYPE II

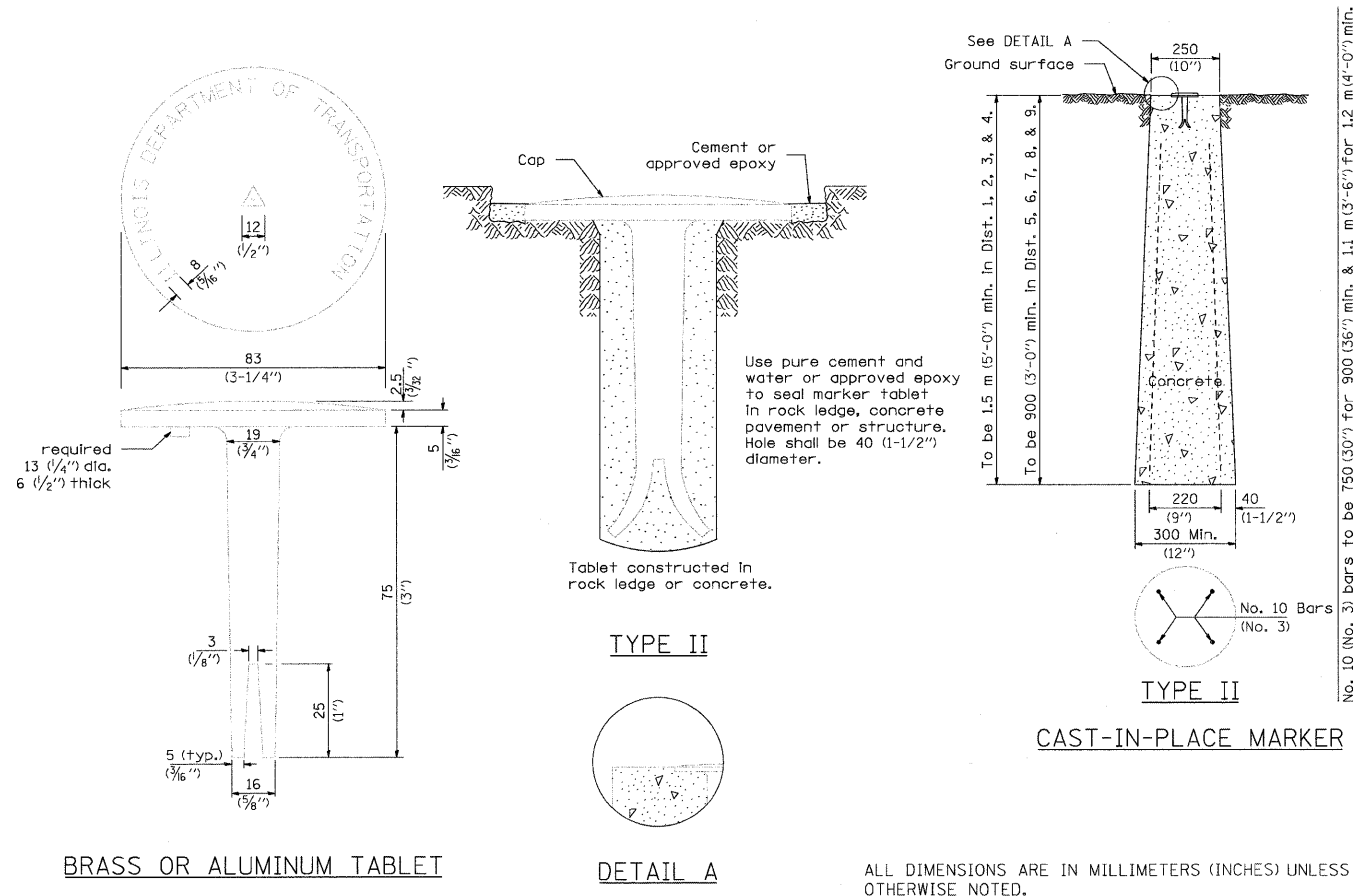

AUTOMATIC FLAP GATE

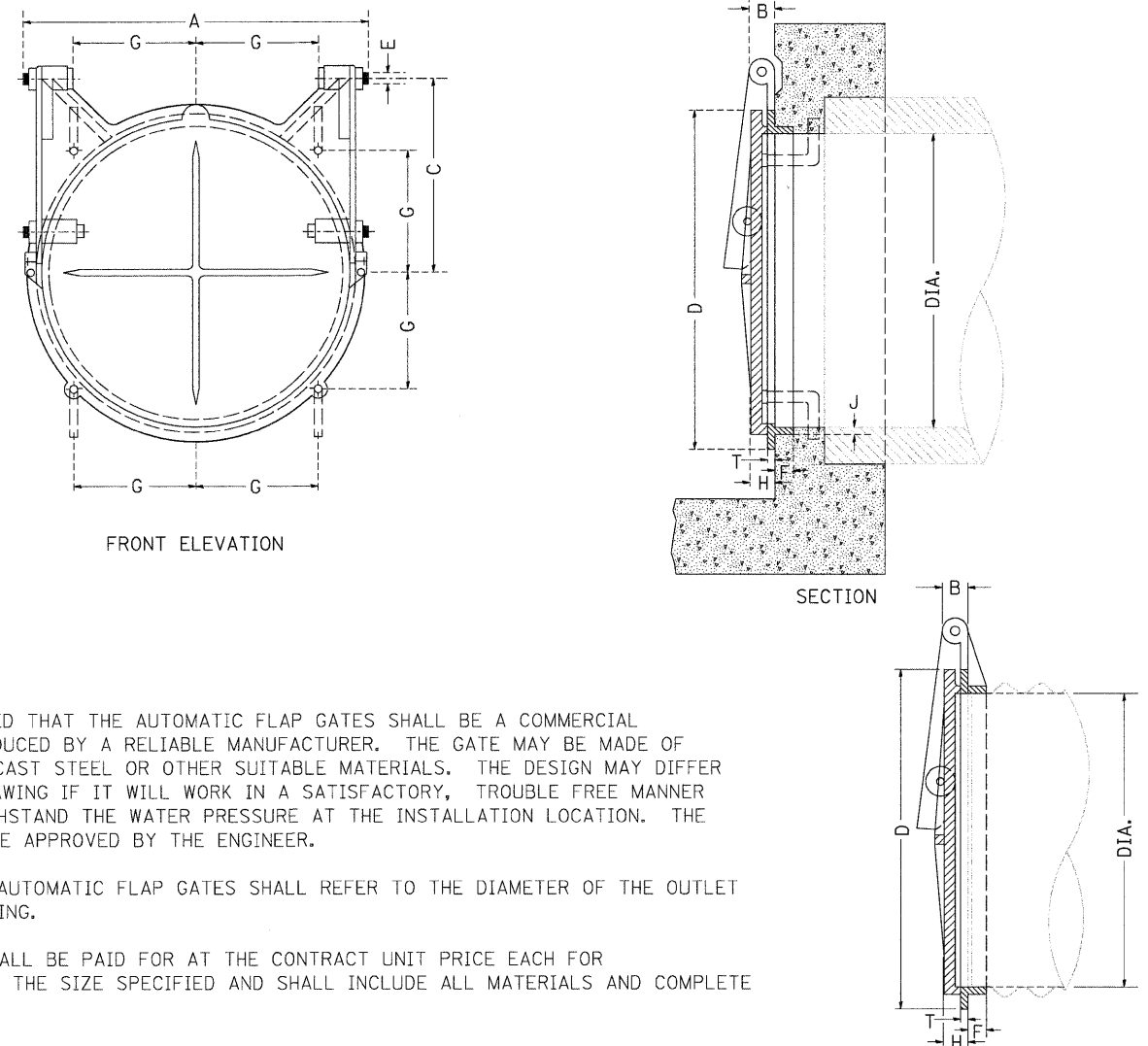

IT IS INTENDED THAT THE AUTOMATIC FLAP GATES SHALL BE A COMMERCIAL PRODUCT PRODUCED BY A RELIABLE MANUFACTURER. THE GATE MAY BE MADE OF CAST IRON, CAST STEEL OR OTHER SUITABLE MATERIALS. THE DESIGN MAY DIFFER FROM THE DRAWING IF IT WILL WORK IN A SATISFACTORY, TROUBLE FREE MANNER AND WILL WITHSTAND THE WATER PRESSURE AT THE INSTALLATION LOCATION. THE GATE SHALL BE APPROVED BY THE ENGINEER.

THE SIZE OF AUTOMATIC FLAP GATES SHALL REFER TO THE DIAMETER OF THE OUTLET PIPE OR OPENING.

THIS WORK SHALL BE PAID FOR AT THE CONTRACT UNIT PRICE EACH FOR FLAP GATE OF THE SIZE SPECIFIED AND SHALL INCLUDE ALL MATERIALS AND COMPLETE INSTALLATION.

ALL DIMENSIONS ARE IN MILLIMETERS (INCHES) UNLESS OTHERWISE NOTED.

TABLE OF DIMENSIONS

DIAM	A	B	C	D	E	F	G	H	J	T
200 (8)	273 (10 3/4)	35 (1 3/8)	144 (5 11/16)	254 10	13 (1/2)	29 (1 1/8)	90 (3 9/16)	32 (1 1/4)	19 (3/8)	10 (3/8)
250 (10)	324 (12 3/4)	35 (1 3/8)	181 (7 1/8)	311 (12 1/4)	13 (1/2)	29 (1 1/8)	111 (4 3/8)	38 (1 1/2)	13 (1/2)	11 (1/16)
300 (12)	375 (14 3/4)	35 (1 3/8)	216 (8 1/2)	368 (14 1/2)	13 (1/2)	29 (1 1/8)	130 (5 1/8)	38 (1 1/2)	13 (1/2)	13 (1/2)
350 (14)	438 (17 1/4)	35 (1 3/8)	251 (9 7/8)	425 (16 3/4)	13 (1/2)	32 (1 1/4)	151 (5 15/16)	38 (1 1/2)	13 (1/2)	14 (9/16)
375 (15)	451 (17 3/4)	35 (1 3/8)	270 (10 5/8)	451 (17 3/4)	13 (1/2)	32 (1 1/4)	159 (6 1/4)	38 (1 1/2)	13 (1/2)	14 (9/16)
400 (16)	489 (19 1/4)	35 (1 3/8)	286 (11 1/4)	476 (18 3/4)	13 (1/2)	32 (1 1/4)	168 (6 5/8)	38 (1 1/2)	13 (1/2)	14 (9/16)
450 (18)	565 (22 1/4)	51 2	321 (12 5/8)	533 21	19 (3/4)	40 (1 5/16)	189 (7 1/16)	44 (1 3/4)	14 (9/16)	14 (9/16)
500 (20)	629 (24 3/4)	51 2	359 (14 1/8)	603 (23 3/4)	19 (3/4)	35 (1 3/8)	210 (8 1/4)	44 (1 3/4)	16 (5/8)	16 (5/8)
525 (21)	641 (25 1/4)	51 2	378 (14 7/8)	616 (24 1/4)	19 (3/4)	35 (1 3/8)	217 (8 5/16)	44 (1 3/4)	16 (5/8)	16 (5/8)
600 (24)	718 (28 1/4)	51 2	432 17	699 (27 1/2)	19 (3/4)	38 (1 1/2)	248 (9 3/4)	44 (1 3/4)	16 (5/8)	16 (5/8)
750 (30)	895 (35 1/4)	64 (2 1/2)	521 (20 1/2)	864 34	25 1	40 (1 9/16)	305 12	51 2	27 (1 1/16)	16 (5/8)
900 (36)	1054 (41 1/2)	64 (2 1/2)	635 25	1038 (40 7/8)	25 1	52 (2 1/16)	367 (14 1/16)	57 (2 1/4)	29 (1 1/8)	17 (11/16)
1050 (42)	1207 (47 1/2)	64 (2 1/2)	756 (29 3/4)	1194 47	25 1	59 (2 5/16)	422 (16 5/8)	57 (2 1/4)	29 (1 1/8)	19 (3/4)
1200 (48)	1359 (53 1/2)	64 (2 1/2)	864 34	1372 54	25 1	70 (2 3/4)	484 (19 1/16)	57 (2 1/4)	35 (1 3/8)	19 (3/4)
1350 (54)	1543 (60 3/4)	64 2 1/2	965 38	1581 (62 1/4)	32 (1 1/4)	70 (2 3/4)	559 22	76 3	38 (1 1/2)	22 (7/8)
1500 (60)	1702 (67)	64 (2 1/2)	1067 42	1740 (68 1/2)	32 (1 1/4)	70 (2 3/4)	616 (24 1/4)	76 3	38 (1 1/2)	24 (5/8)
1650 (66)	1855 (73 3/8)	64 (2 1/2)	1194 47	1905 75	32 (1 1/4)	73 (2 7/8)	673 (26 1/2)	76 3	38 (1 1/2)	25 1
1800 (72)	2007 (79)	64 (2 1/2)	1295 51	2083 82	32 (1 1/4)	76 3	737 29	76 3	38 (1 1/2)	25 1
1950 (78)	2184 (86)	64 (2 1/2)	1403 (55 1/4)	2254 (88 3/4)	32 (1 1/4)	89 (3 1/2)	797 (31 3/8)	76 3	41 (1 5/8)	29 (1 1/8)
2100 (84)	2350 (92 1/2)	89 (3 1/2)	1511 (59 1/2)	2426 (95 1/2)	38 (1 1/2)	89 (3 1/2)	857 (33 3/4)	76 3	44 (1 3/4)	32 (1 1/4)

NAME PLATE FOR CULVERTS

FOR 24"-42" PIPE CULVERTS

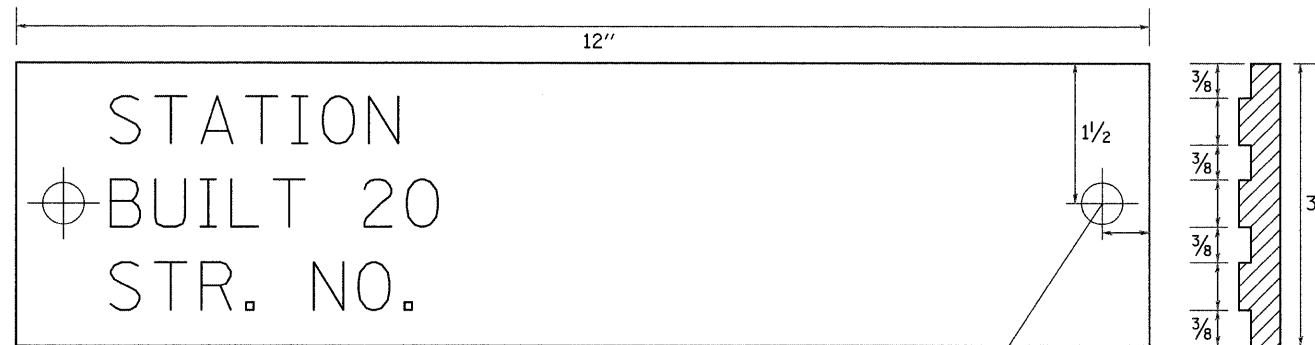

FOR 48"-84" PIPE CULVERTS

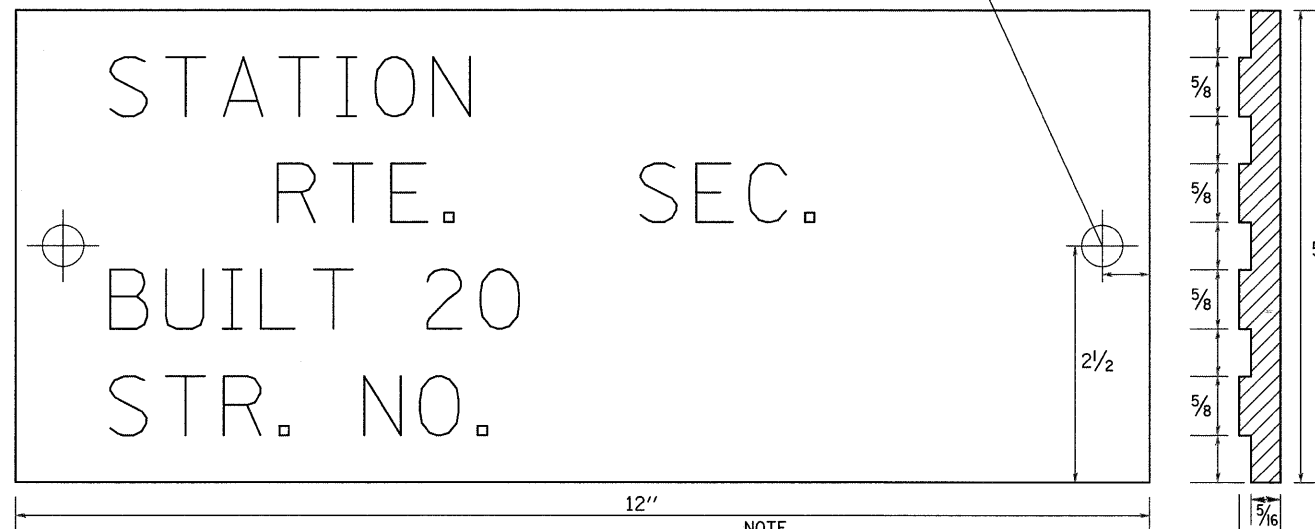

NOTE
LETTERING RAISED 1/8, SQUARE CUT AND NOT TAPERED

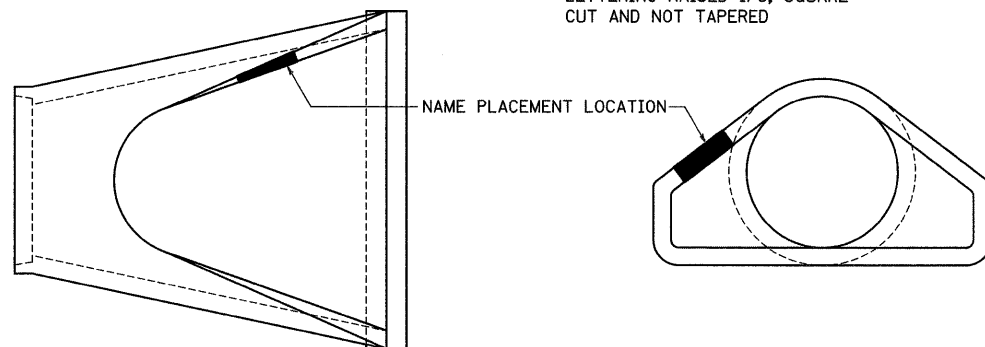

DESIGNERS NOTE

NAME PLATES SHALL BE FURNISHED & INSTALLED ACCORDING TO SECTION 515 OF THE STANDARD SPECIFICATIONS, EXCEPT 2 BOLTS SHALL BE USED TO FASTEN THE PLATE TO THE END SECTION.

USE STANDARD 515001 FOR BRIDGES AND MULTI-CELL CULVERTS WITH SPANS OF 20' OR MORE MEASURED ALONG THE CENTERLINE AT THE HIGHWAY.

USE THIS DETAIL FOR ALL OTHER PIPE CULVERTS & BOX CULVERTS WITH STRUCTURE NUMBERS. INCLUDE THE INFORMATION TO FILL OUT THE NAME PLATE FOR EACH CULVERT.

IN BOTH CASES INCLUDE A PAY ITEM FOR NAME PLATES.

STATION	STRUCTURE NO.
651+65.08	037-1184

REVISED - 5-27-09

ROUGH GROOVED SURFACE SIGN

ILLINOIS STANDARD W8-I107

SIGN PANEL TYPE 1



COLOR: LEGEND AND BORDER - BLACK NON-REFLECTIVE
BACKGROUND - ORANGE REFLECTORIZED

SIGN SIZE	DIMENSIONS							
	A	B	C	D	E	F	G	H
1200x1200 (48x48)	1200 (48.0)	600 (24.1)	75 (3.0)	850 (34.0)	825 (33.0)	150 (6.0)	325 (13.0)	88 (3.5)

SIGN SIZE	SERIES			MARGIN	BORDER	BLANK STD.
	LINES					
	1	2	3			
1200x1200 (48x48)	7C	7C	7C	20 (0.8)	30 (1.2)	B4-48D

ALL DIMENSIONS IN INCHES.

GENERAL NOTES

SIGN PANELS AND FACE MATERIALS SHALL BE ACCORDING TO SECTION 720 OF THE STANDARD SPECIFICATIONS

METAL POSTS SHALL BE IN ACCORDANCE WITH STD. 720011.

ALL MOUNTING HARDWARE SHALL BE ALUMINUM, STAINLESS STEEL, ZINC OR CADMIUM PLATED STEEL AND SHALL BE INCLUDED TO THE COST OF THE INSTALLATION.

ALL DIMENSIONS ARE IN MILLIMETERS (INCHES) UNLESS OTHERWISE NOTED.

REVISED	REVISION	SCALE: 1:0000 ' / IN.	SHEET NO.	OF	SHEETS	STA.	TO STA.	F.A.P. RTE.	SECTION	COUNTY	TOTAL SHEETS	SHEET NO.
								585	128 BR	HENRY	106	72
								FED. ROAD DIST. NO. 2 ILLINOIS FED. AID PROJECT				
								CONTRACT NO. 64C20				

PLOT DATE = 7/21/2011

CONCRETE COLLARS FOR PIPE OR BOX CULVERT EXTENSIONS

Bill of Materials

STATION	DIMENSIONS		u Bar	h Bar	EXPANSION BOLTS	CONCRETE COLLAR	REINF. BARS
	X	Y	No.	No.			
-	10'-4"	5'-0"	8	84	1'-6"	28	4
All h Bars 450 (18) Long					Total		

General Notes

Concrete Collars shall be constructed of Class SI Concrete in accordance with Section 503 of the Standard Specifications

Reinforcement bars shall conform to Section 508 of the Standard Specifications.

The concrete will be paid for at the contract unit price per cubic meter (cubic yard) for CONCRETE COLLAR. Reinforcement will be paid for at the contract unit price per kilogram (pound) for REINFORCEMENT BARS. Expansion Bolts, when required, will be paid for at the contract unit price each for EXPANSION BOLTS of the size indicated, which price shall include furnishing, drilling holes, and installing the expansion bolts complete in place. These bolts shall extend at least 200 (8) inches into the new concrete.

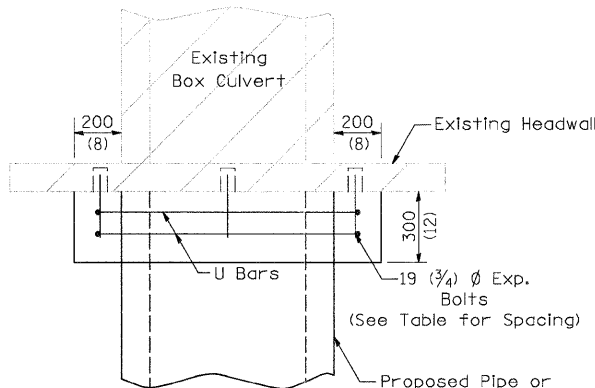

PLAN OF CULVERT WITH STRAIGHT HEADWALL

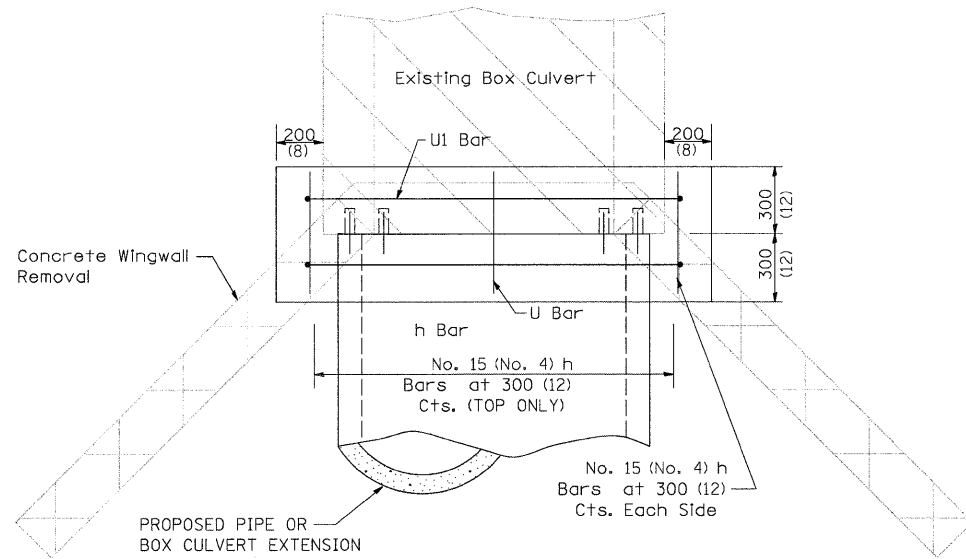

PLAN OF CULVERT WITH ANGLED WING WALLS

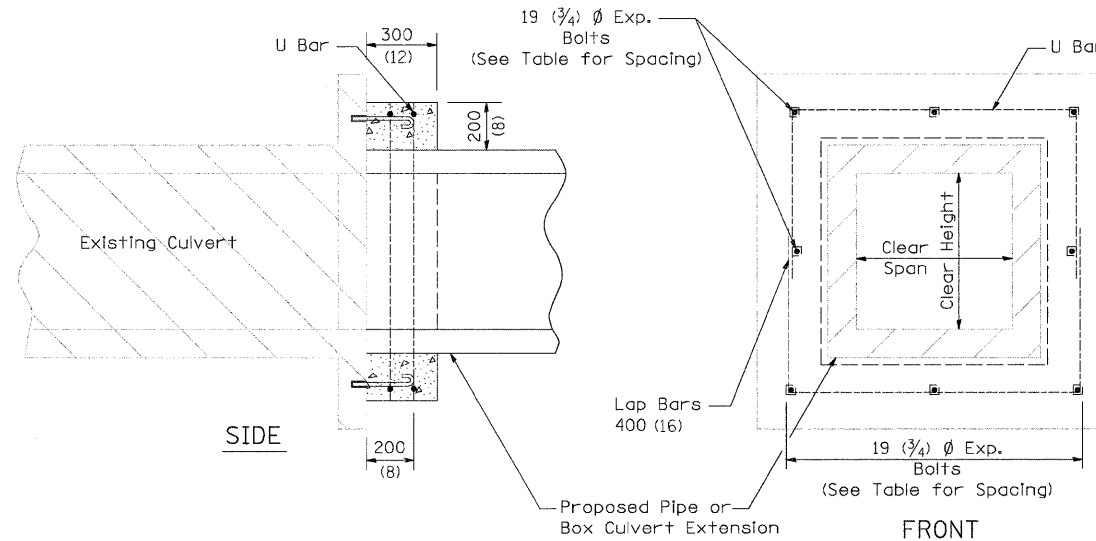

SIDE

FRONT

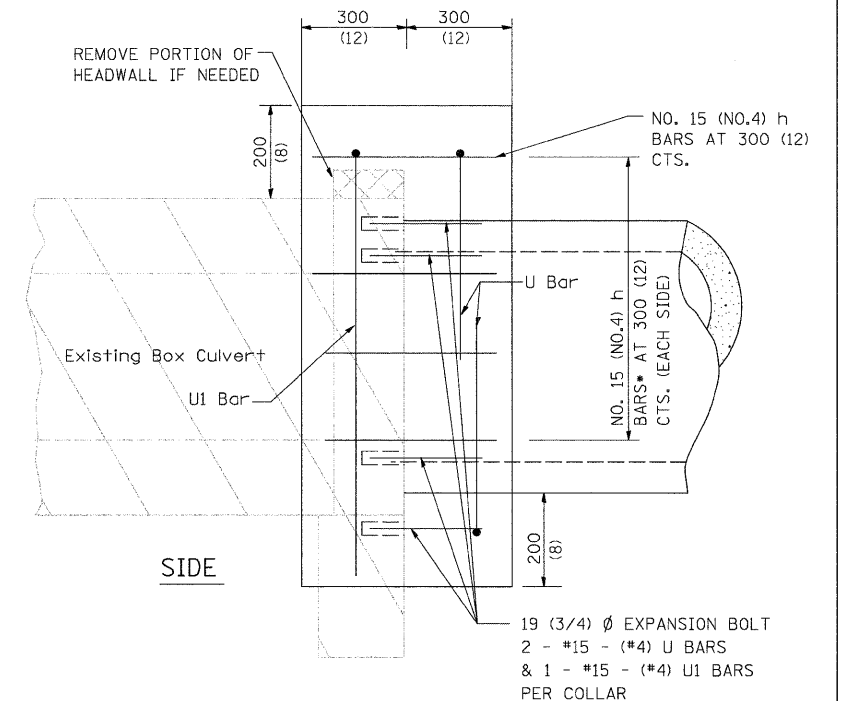

SIDE

PLACEMENT DETAILS FOR EXPANSION BOLTS

H OR S	NUMBER OF EXPANSION BOLTS REQUIRED PER SIDE			
	EXTENSIONS < 4.57m (15')		EXTENSIONS > 4.57m (15')	
	NUMBER	SPACING	NUMBER	SPACING
600 (24)	*		*	
750 (30)	2	450 (18)	2	450 (18)
900 (36)	2	600 (24)	2	600 (24)
1200 (48)	3	450 (18)	3	450 (18)
1500 (60)	4	400 (16)	3	600 (24)
1800 (72)	5	375 (15)	4	500 (20)
2100 (84)	5	450 (18)	4	600 (24)
2400 (96)	6	375 (15)	5	525 (21)
2700 (108)	6	475 (19)	5	600 (24)
3000 (120)	7	450 (18)	6	525 (21)
3300 (132)	8	425 (17)	6	600 (24)
3600 (144)	8	475 (19)	7	550 (22)

* MINIMUM ONE PER SIDE

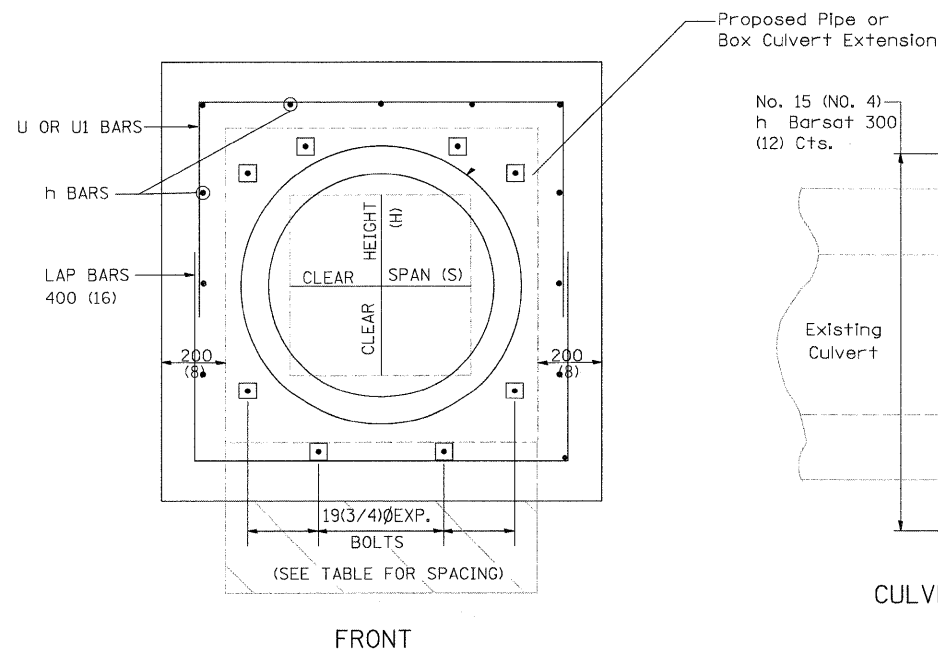

FRONT

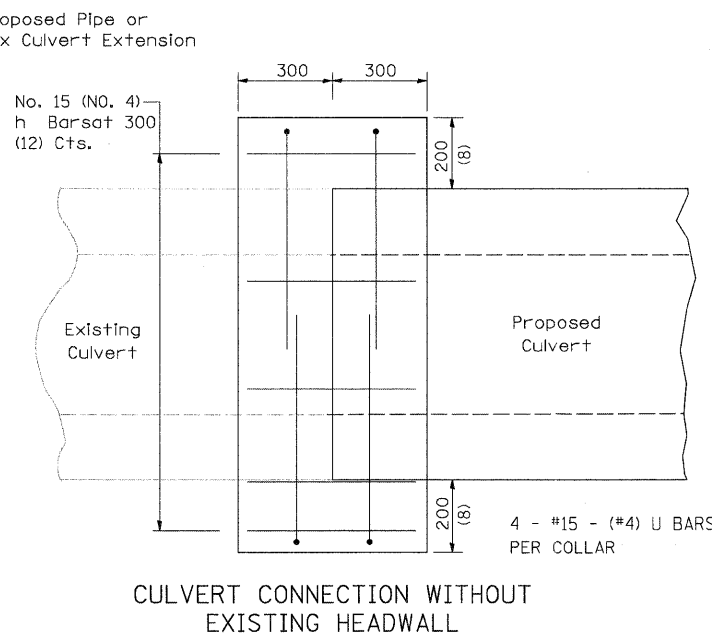

CULVERT CONNECTION WITHOUT EXISTING HEADWALL

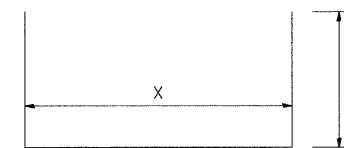

(#4) U BAR

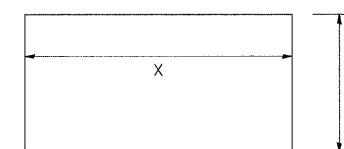

(#4) U1 BAR

TYPICAL PAVEMENT MARKINGS

ARROW LAYOUT

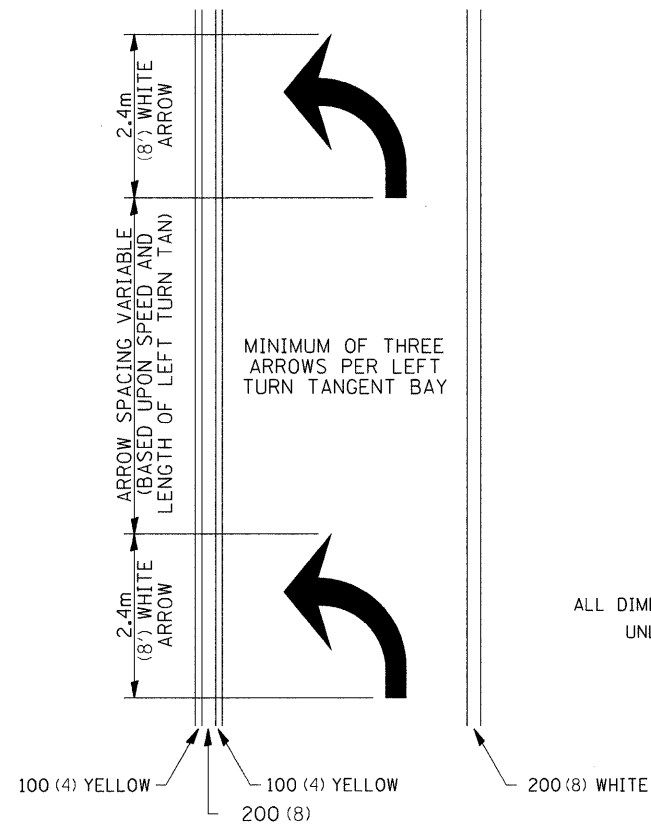

12.2m
6 at (40') O.C.
APPROACH SIDE ONLY

TYPICAL PAVEMENT MARKING FOR FLUSH MEDIAN

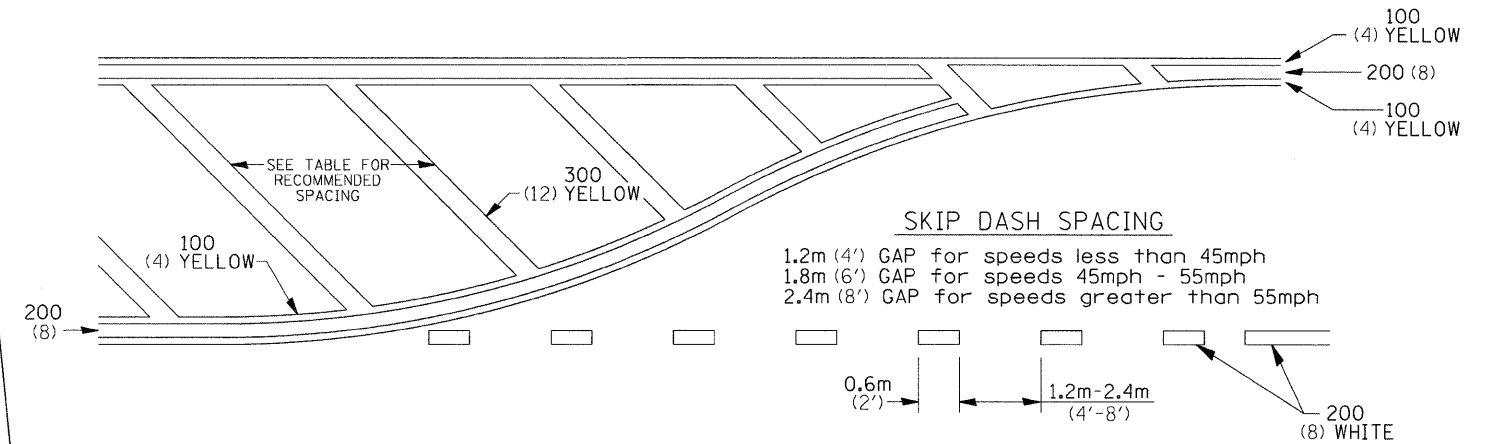

RECOMMENDED SPACING BETWEEN DIAGONALS (IN FEET)

Speed Limit Range	Continuous Median Area	Intersection Channelization	Objects (Islands)
less than 50Km/H (30MPH)	15.3m (50')	4.53m (15')	3.05m (10')
50-60Km/H (30-40MPH)	22.9m (75')	6.1m (20')	4.53m (15')
70Km/H (45MPH) & over	22.9m (75')	9.05m (30')	6.1m (20')

NOTE: If the spacing recommended in the Table does not permit at least five diagonal lines in the area being marked, the spacing from the next lowest speed range should be used. The recommended spacing is measured parallel to the pavement center line.

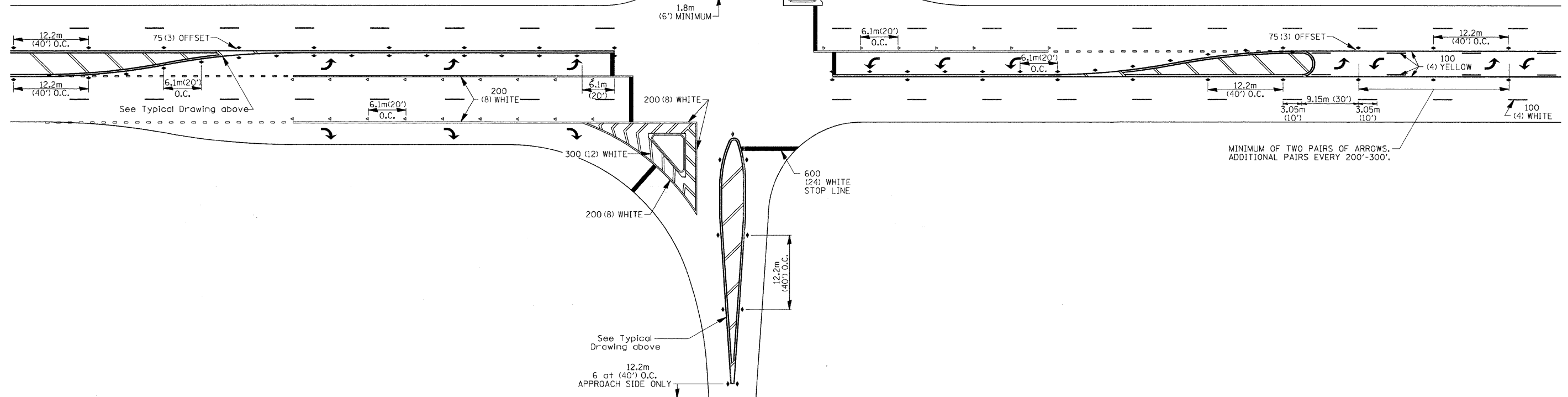

TYPICAL PAVEMENT MARKINGS

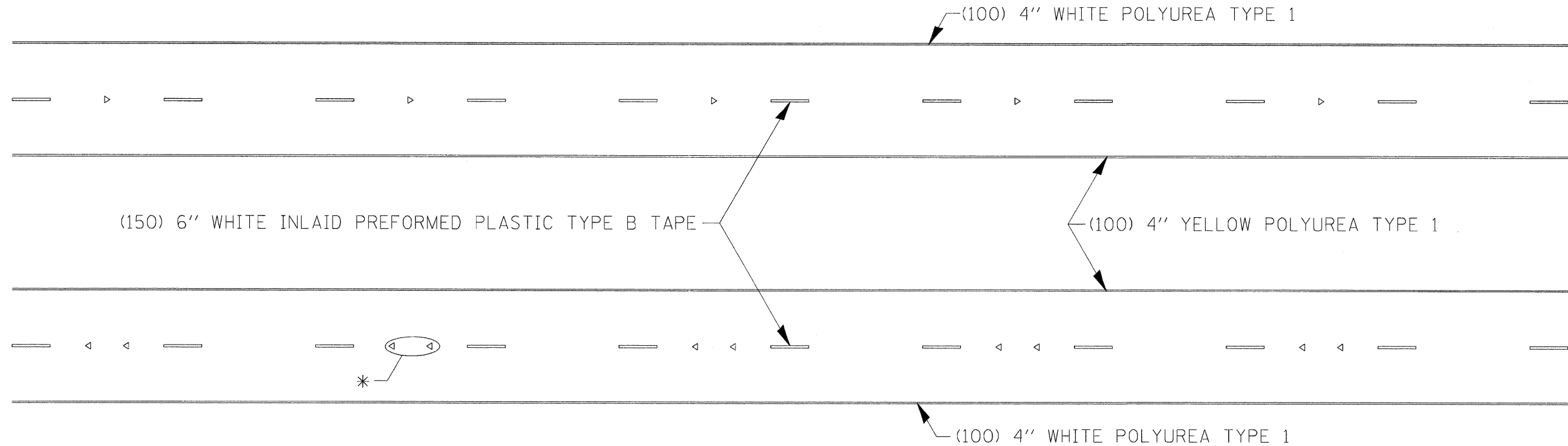

* SEE HIGHWAY STANDARD 781001 FOR SPACING DETAILS.
USE DOUBLE MARKERS WHEN ADT \geq 25,000.

MULTI-LANE / DIVIDED

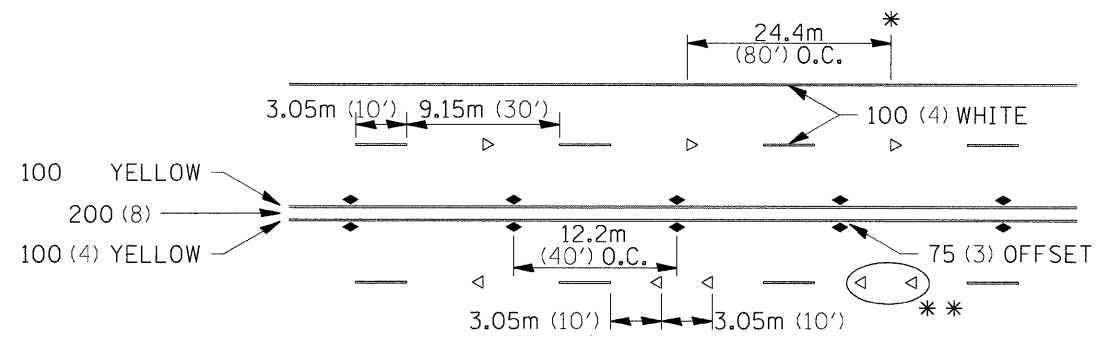

- * REDUCE TO 12.2m (40') O.C. ON CURVES WHERE ADVISORY SPEEDS ARE 15Km/H (10MPH) LOWER THAN POSTED SPEEDS.
- ** USE DOUBLE MARKERS WHEN ADT \geq 25,000

MULTI-LANE / UNDIVIDED

(FOR MULTI-LANE UNDIVIDED HIGHWAYS USE THIS
DETAIL NOT HIGHWAY STANDARD 781001)

TYPICAL PAVEMENT MARKING FOR TWO LANE SECTION - NO PASSING ZONES

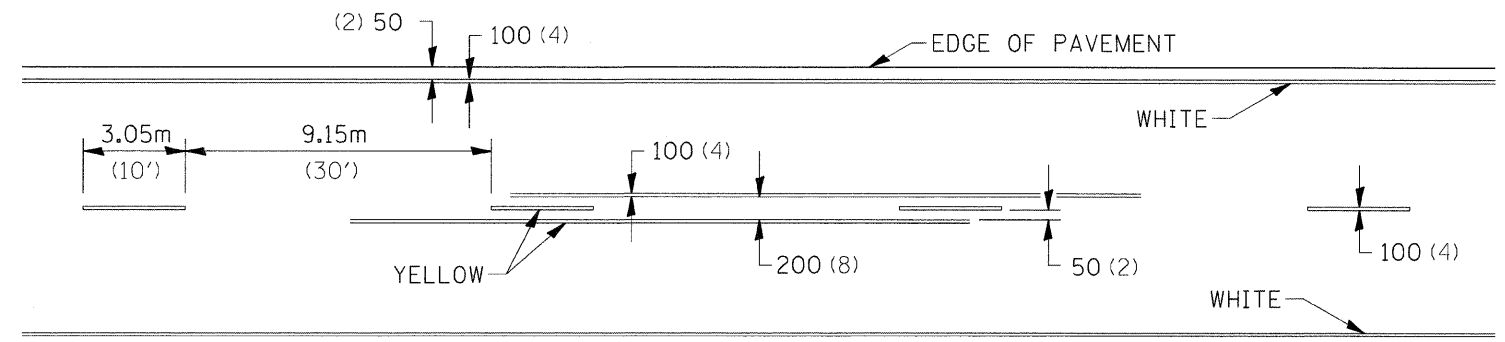

SYMBOLS

FILE NAME = st\joi\6300--6399\6346\027\micro\sh\sh	USER NAME = brianf t-districtdetails.dgn	DESIGNED - DRAWN -	REVISED - 4-4-11 REVISED -	STATE OF ILLINOIS DEPARTMENT OF TRANSPORTATION	REGION 2 / DISTRICT 2 STANDARD				F.A.P. RTE. 585	SECTION 128 BR	COUNTY HENRY	TOTAL SHEETS 106	SHEET NO. 76
					SCALE:	SHEET NO.	OF	SHEETS	STA.	TO STA.	CONTRACT NO. 64C20		
					FED. ROAD DIST. NO. 2 ILLINOIS FED. AID PROJECT								

FINAL SURVEY	SURVEYED	DATE
NOTE BOOK	PLotted	BY
NO.	TEMPLATE	
	AREAS	
	CHECKED	

ORIGINAL SURVEY	SURVEYED	DATE
NOTE BOOK	PLotted	BY
NO.	TEMPLATE	
	AREAS	
	CHECKED	

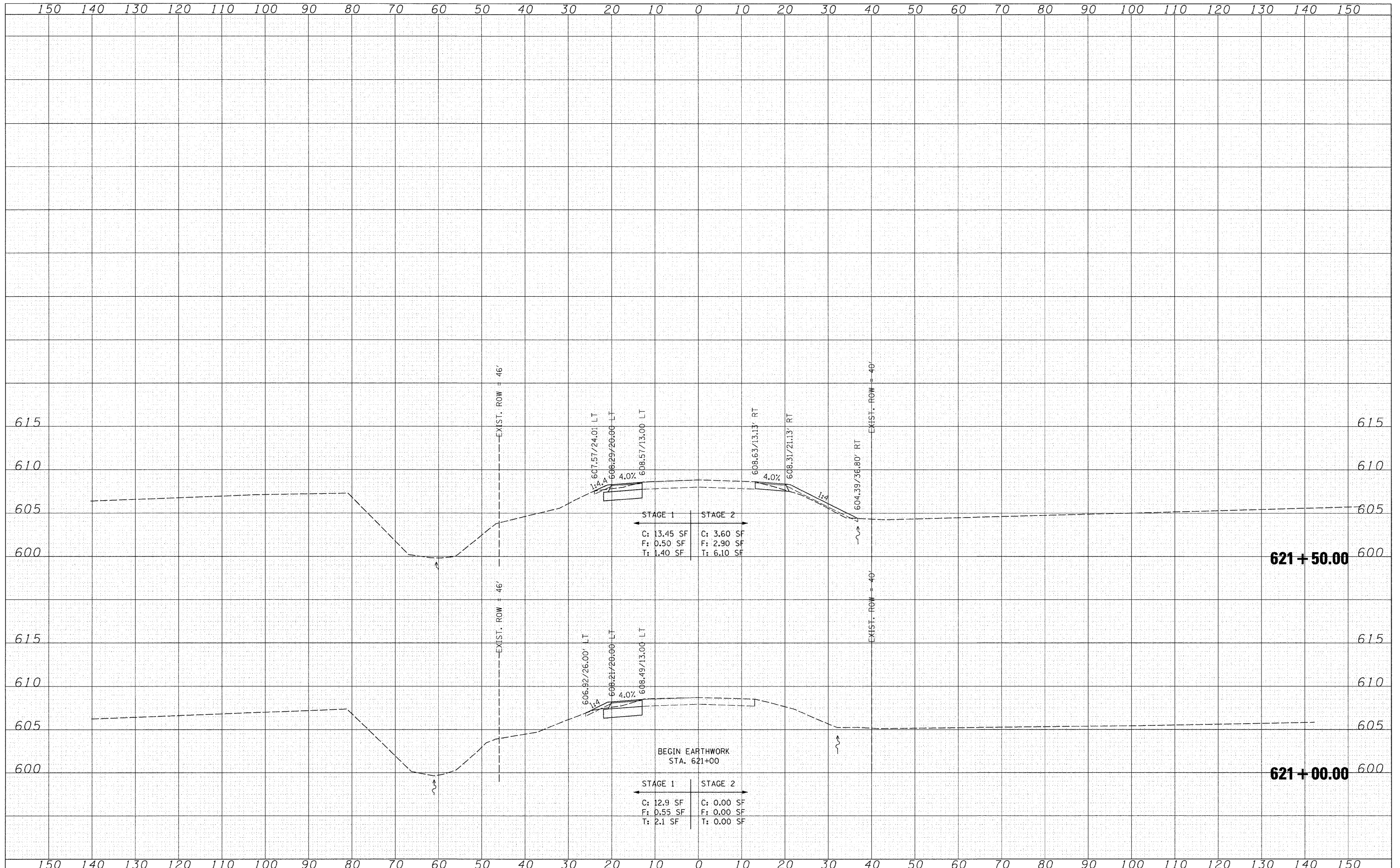

FILE NAME = S:\JDL\6300-6399\6346\227\Micros\Sh\shh\shh.dgn
 USER NAME = brianf
 PLOT SCALE = 10,000 / IN.
 PLOT DATE = 7/19/2011

DESIGNED -	REVISED -
CHECKED -	REVISED -
DRAWN -	REVISED -
CHECKED -	REVISED -

**STATE OF ILLINOIS
DEPARTMENT OF TRANSPORTATION**

**CROSS SECTIONS
S.N. 037-0174**

SCALE: SHEET NO. OF SHEETS STA. 621+00.00 TO STA. 621+50.00

F.A.P. RTE.	SECTION	COUNTY	TOTAL SHEETS	SHEET NO.
585	128 BR	HENRY	106	77
CONTRACT NO. 64C20				
FED. ROAD DIST. NO. 2 ILLINOIS FED. AID PROJECT				

FINAL SURVEY	DATE
SURVEYED	BY
TEMPLATE	
NOTE BOOK	
AREAS CHECKED	
NO.	

ORIGINAL SURVEY	DATE
SURVEYED	BY
TEMPLATE	
NOTE BOOK	
AREAS CHECKED	
NO.	

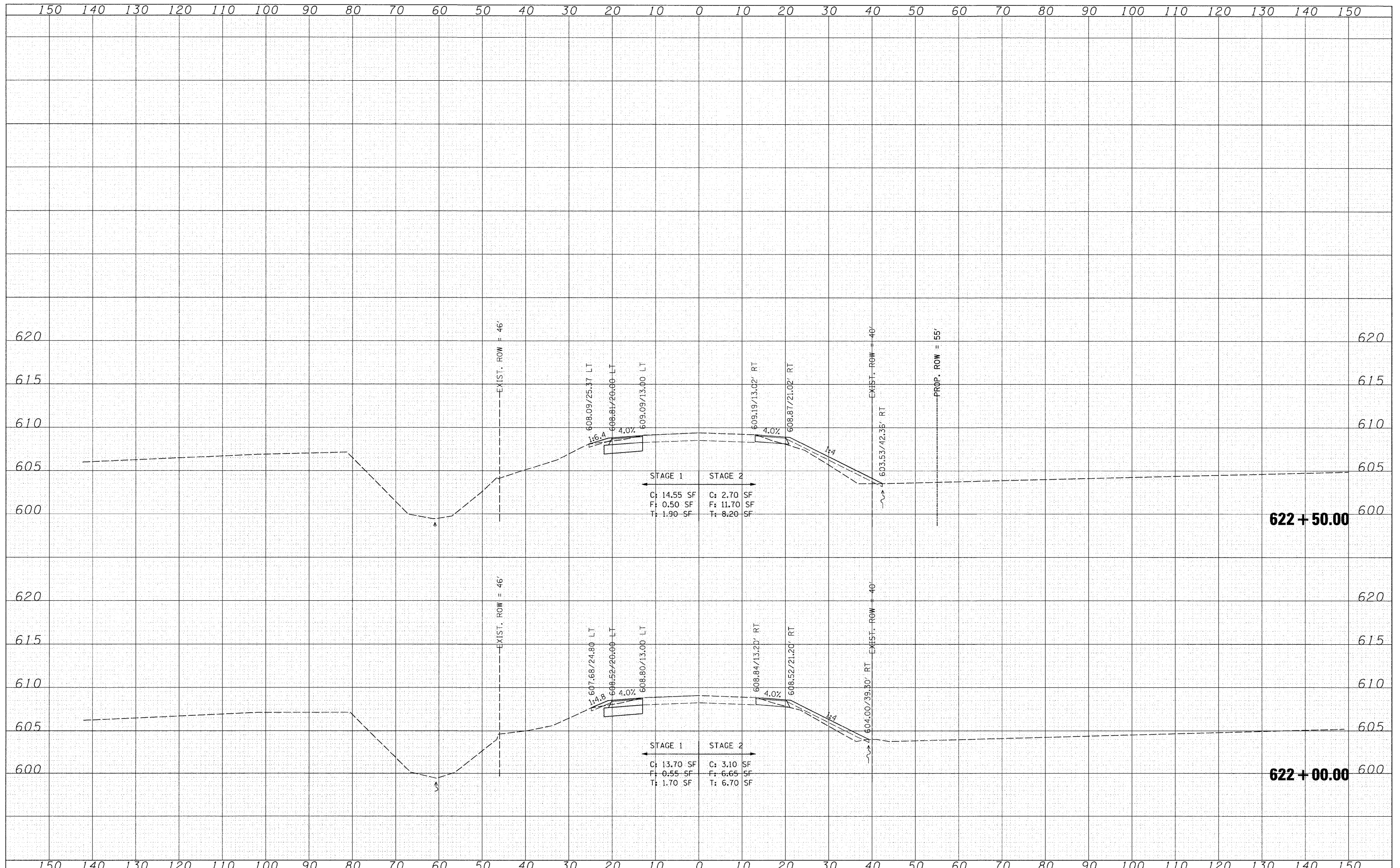

FINAL SURVEYED	BY	DATE
SURVEYED		
NOTE BOOK		
NO.		
AREAS		
CHECKED		

ORIGINAL SURVEYED	BY	DATE
SURVEYED		
NOTE BOOK		
NO.		
AREAS		
CHECKED		

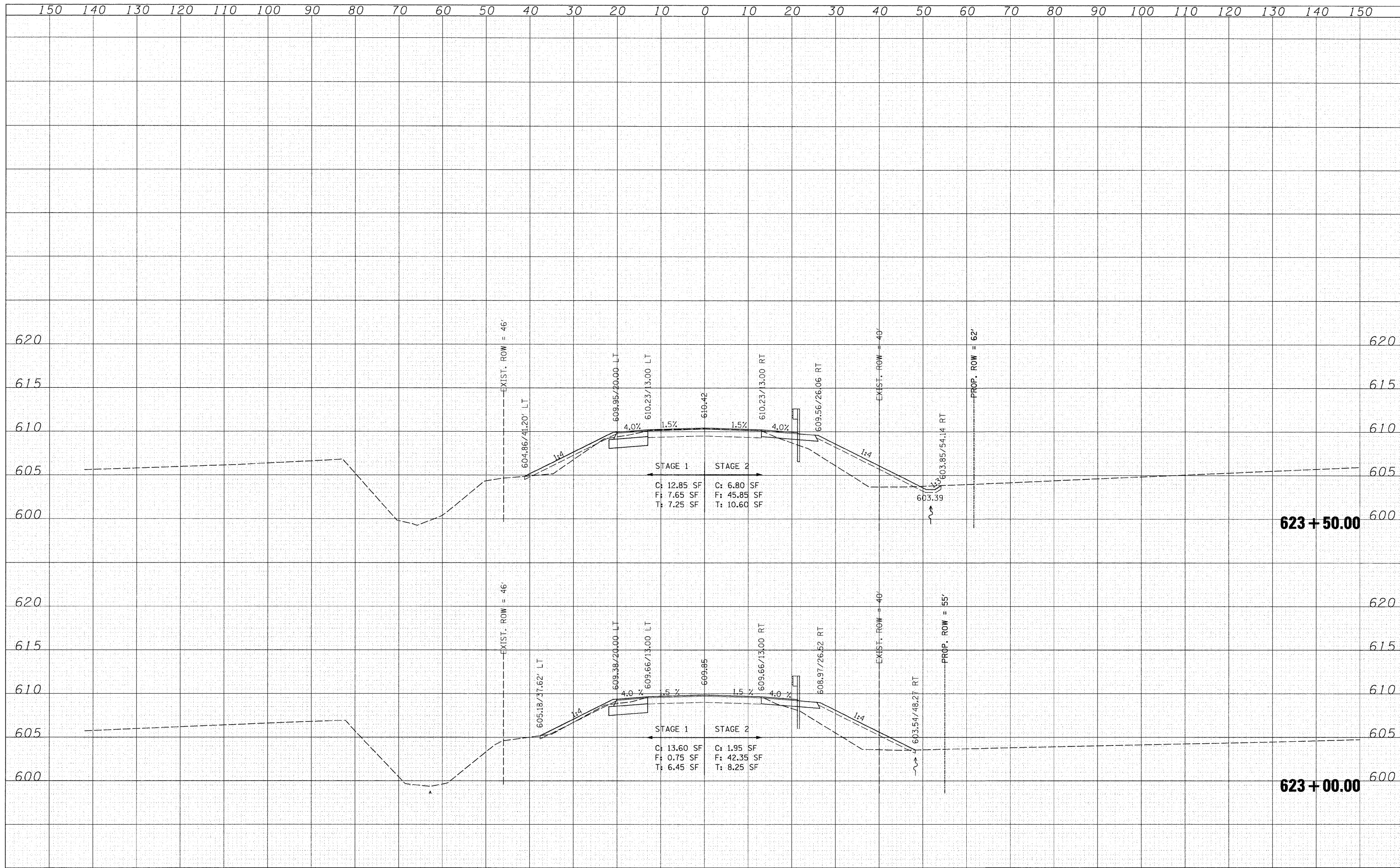

FINAL SURVEY	DATE
SURVEYED	BY
NOTE BOOK	
TEMPLATE	
AREAS CHECKED	
NO.	

ORIGINAL SURVEY	DATE
SURVEYED	BY
NOTE BOOK	
TEMPLATE	
AREAS CHECKED	
NO.	

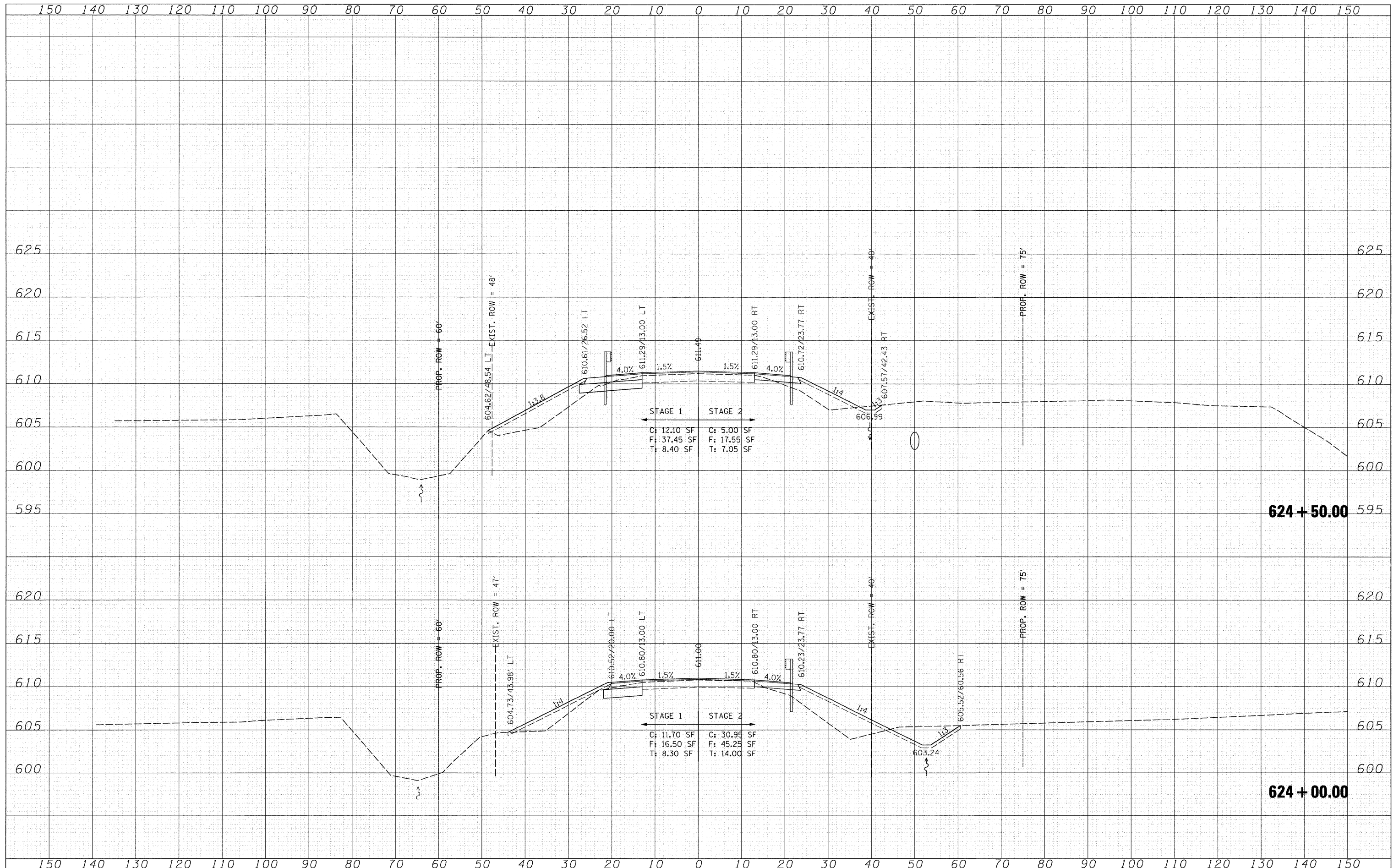

FILE NAME = S:\JOL\6302--6399\6346\027\Micro\Sh\sh\sshd.dgn
 USER NAME = brtanf
 PLOT SCALE = 10,0000 ' / IN.
 PLOT DATE = 7/19/2011

DESIGNED VLF
 CHECKED RKK
 DRAWN VLF
 CHECKED RKK

REVISED -
 REVISED -
 REVISED -
 REVISED -

STATE OF ILLINOIS
 DEPARTMENT OF TRANSPORTATION

CROSS SECTIONS
 S.N. 037-0174

SCALE: SHEET NO. OF SHEETS STA. 624+00.00 TO STA. 624+50.00

F.A.P. RTE.	SECTION	COUNTY	TOTAL SHEETS	SHEET NO.
585	128 BR	HENRY	106	80
CONTRACT NO. 64C20				
FED. ROAD DIST. NO. 2 ILLINOIS FED. AID PROJECT				

FINAL SURVEY	DATE
SURVEYED	BY
NOTE BOOK	
TEMPLATE	
AREAS	
CHECKED	
NO.	

ORIGINAL SURVEY	DATE
SURVEYED	BY
NOTE BOOK	
TEMPLATE	
AREAS	
CHECKED	
NO.	

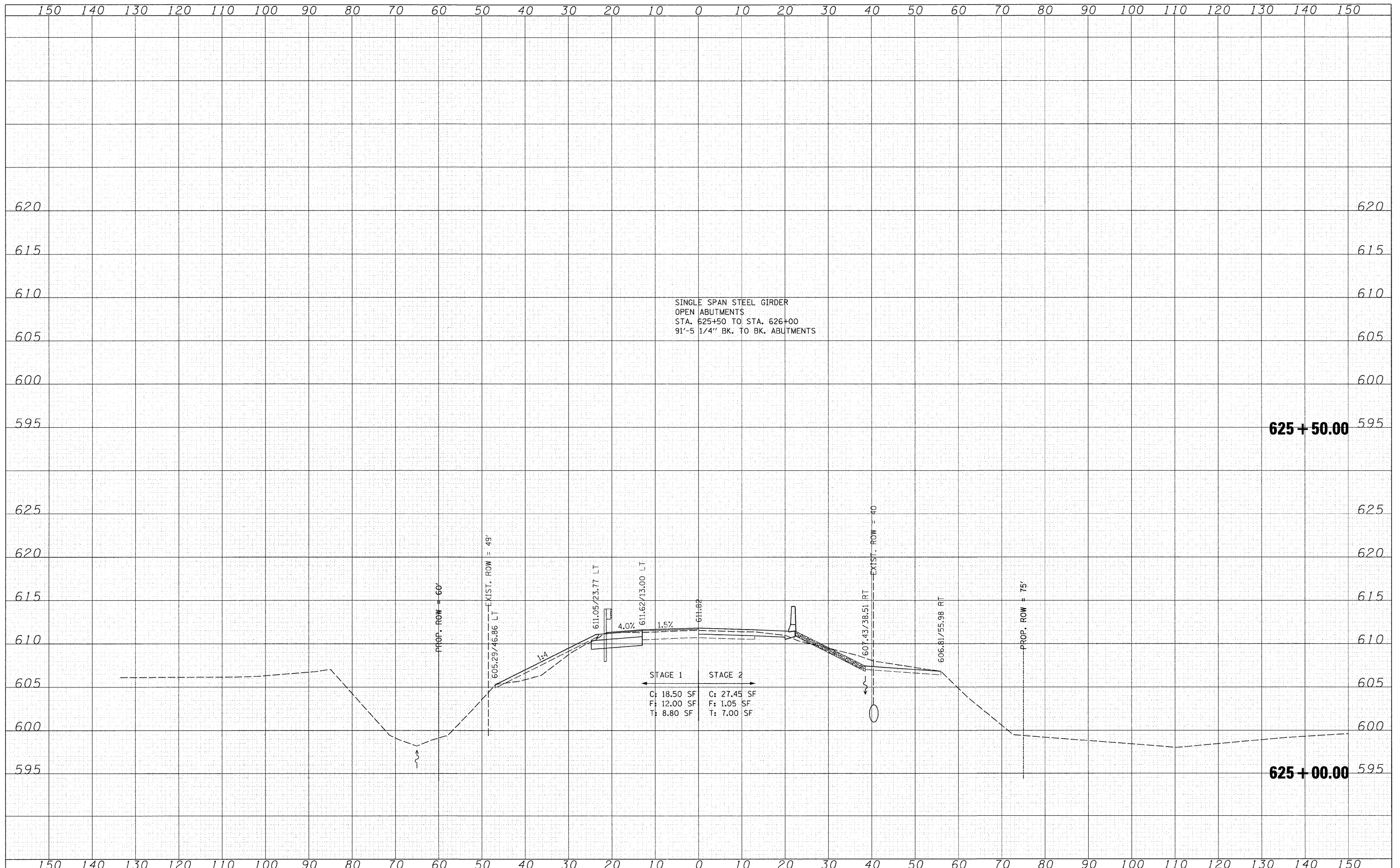

SINGLE SPAN STEEL GIRDER
 OPEN ABUTMENTS
 STA. 625+50 TO STA. 626+00
 91'-5 1/4" BK. TO BK. ABUTMENTS

STAGE 1	STAGE 2
C: 18.50 SF	C: 27.45 SF
F: 12.00 SF	F: 1.05 SF
T: 8.80 SF	T: 7.00 SF

FILE NAME = Sr\JOL\6302--6399\6346\027\Microsoft\Sh\shnt-xsshd.dgn

USER NAME = brtanf
 PLOT SCALE = 10,0000' / IN.
 PLOT DATE = 7/19/2011

DESIGNED VLF
 CHECKED RKK
 DRAWN VLF
 CHECKED RKK

REVISED -
 REVISED -
 REVISED -
 REVISED -

STATE OF ILLINOIS
 DEPARTMENT OF TRANSPORTATION

CROSS SECTIONS
 S.N. 037-0174

SCALE: SHEET NO. OF SHEETS STA. 625+00.00 TO STA. 625+50.00

F.A.P. RTE.	SECTION	COUNTY	TOTAL SHEETS	SHEET NO.
585	128 BR	HENRY	106	81
CONTRACT NO. 64C20				
FED. ROAD DIST. NO. 2 ILLINOIS FED. AID PROJECT				

FINAL SURVEY	DATE
SURVEYED	BY
NOTE BOOK	
TEMPLATE	
AREAS CHECKED	
NO.	

ORIGINAL SURVEY	DATE
SURVEYED	BY
NOTE BOOK	
TEMPLATE	
AREAS CHECKED	
NO.	

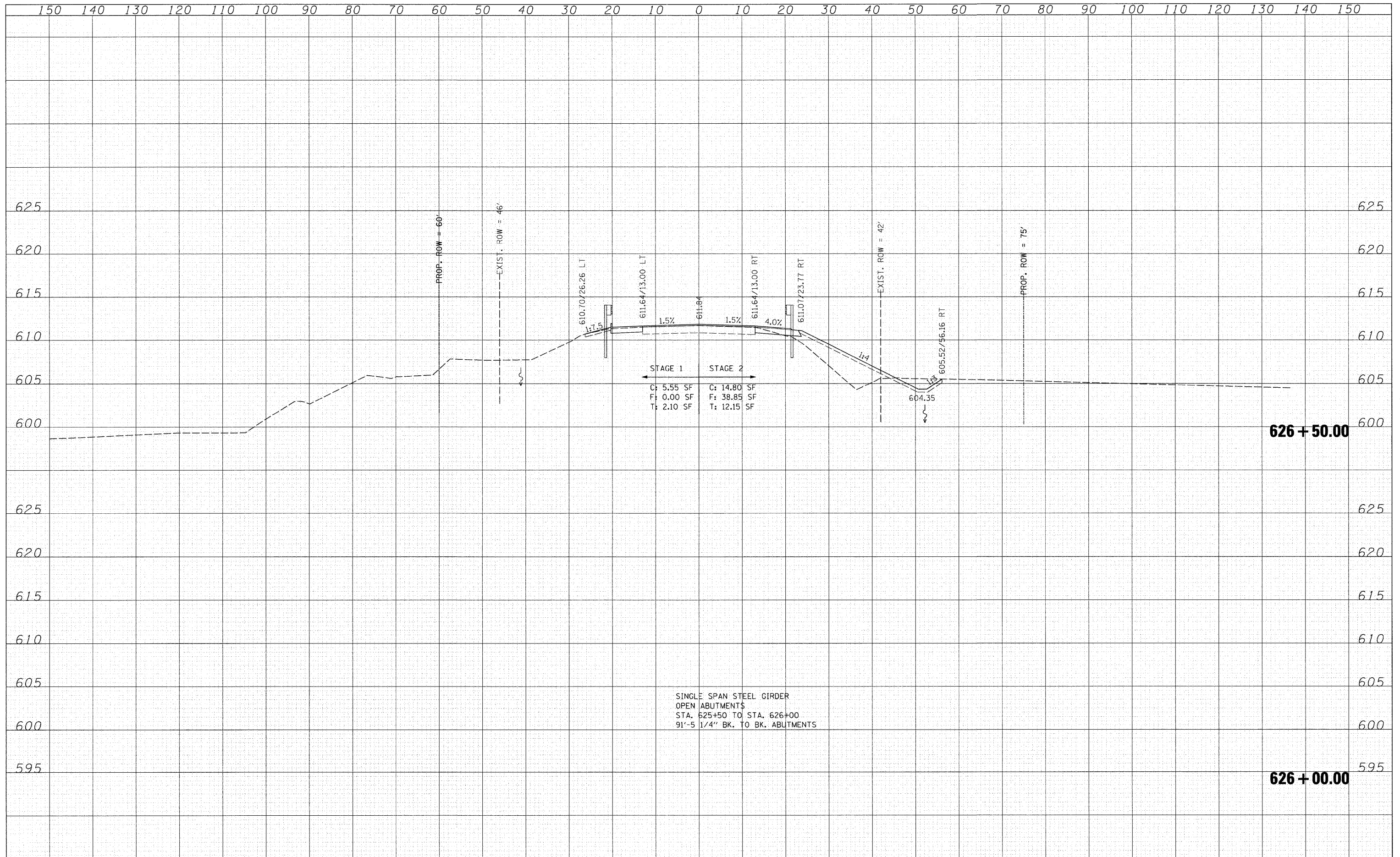

STAGE 1 STAGE 2

C: 5.55 SF C: 14.80 SF
 F: 0.00 SF F: 38.85 SF
 T: 2.10 SF T: 12.15 SF

SINGLE SPAN STEEL GIRDER
 OPEN ABUTMENTS
 STA. 625+50 TO STA. 626+00
 91'-5" 1/4" BK. TO BK. ABUTMENTS

FILE NAME = S:\JOL\6300-6399\6346\027\Micros\Shit\shh\cl.dgn	USER NAME = br1anf	DESIGNED VLF	REVISIED -	STATE OF ILLINOIS DEPARTMENT OF TRANSPORTATION	CROSS SECTIONS S.N. 037-0174				F.A.P. RTE. 585	SECTION 128 BR	COUNTY HENRY	TOTAL SHEETS 106	SHEET NO. 82
	PLOT SCALE = 10,0000' / IN.	CHECKED RKK	REVISIED -		SCALE:	SHEET NO.	OF	SHEETS	STA. 626+00.00	TO STA. 626+50.00	CONTRACT NO. 64C20		
	PLOT DATE = 7/19/2011	DRAWN VLF	REVISIED -		FED. ROAD DIST. NO. 2 ILLINOIS FED. AID PROJECT								
		CHECKED RKK	REVISIED -										

FINAL SURVEY	DATE
SURVEYED	BY
PLANS	
TEMPLATE	
NOTE BOOK	
AREAS	
CHECKED	
NO.	

ORIGINAL SURVEY	DATE
SURVEYED	BY
PLANS	
TEMPLATE	
NOTE BOOK	
AREAS	
CHECKED	
NO.	

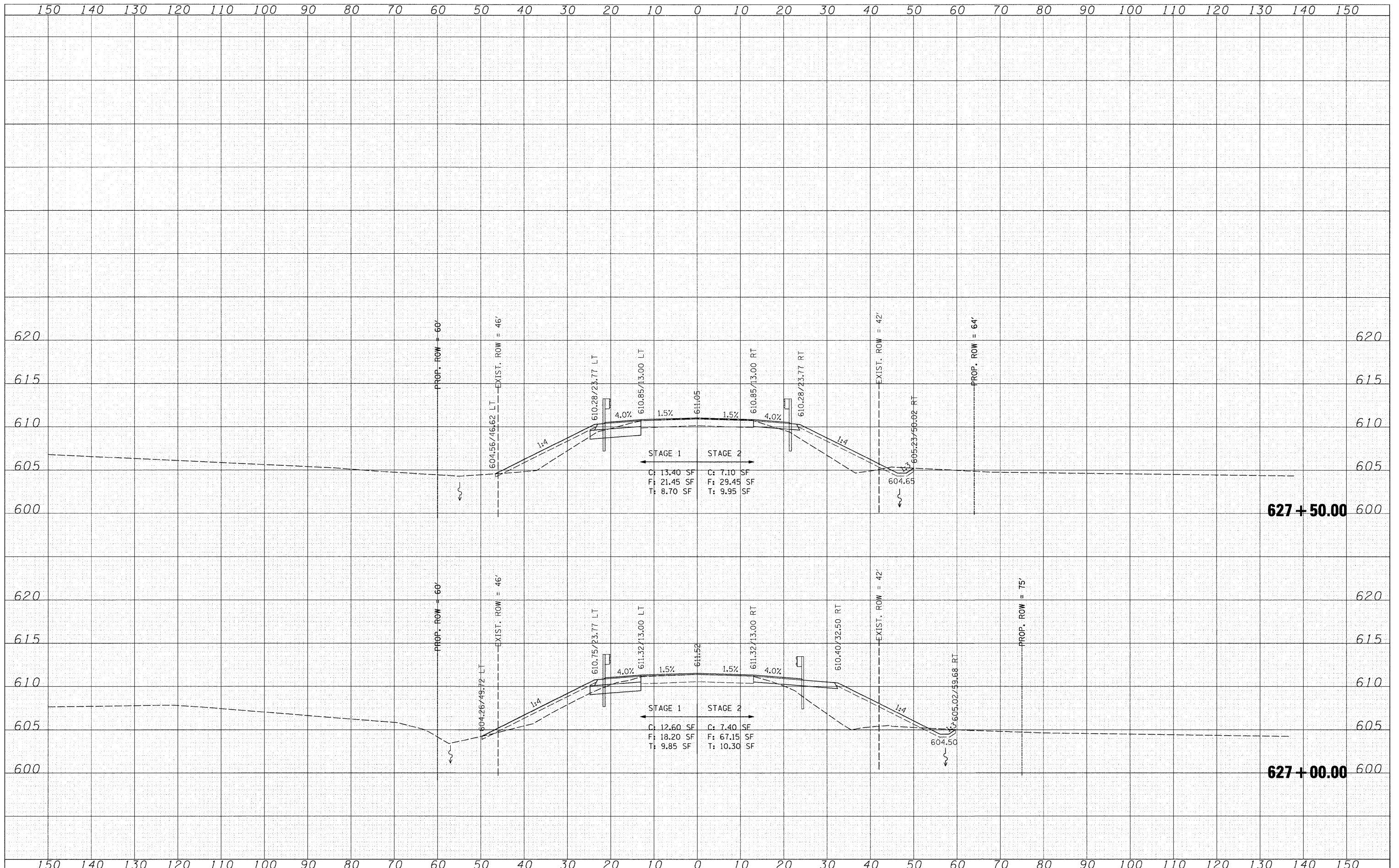

FILE NAME = S:\JOL\6320-6399\6346\027\Microsoft\Sh\sh\sh\dgn

USER NAME = brisanf
 PLOT SCALE = 10.0000 "/p>

DESIGNED VLF
 CHECKED RKK
 DRAWN VLF
 CHECKED RKK

REVISED -
 REVISED -
 REVISED -
 REVISED -

**STATE OF ILLINOIS
 DEPARTMENT OF TRANSPORTATION**

**CROSS SECTIONS
 S.N. 037-0174**

SCALE: SHEET NO. OF SHEETS STA. 627+00.00 TO STA. 627+50.00

F.A.P. RTE.	SECTION	COUNTY	TOTAL SHEETS	SHEET NO.
585	128 BR	HENRY	106	83
FED. ROAD DIST. NO. 2 ILLINOIS FED. AID PROJECT				
CONTRACT NO. 64C20				

FINAL SURVEY	DATE
SURVEYED	BY
NOTE BOOK	
TEMPLATE	
AREAS	
CHECKED	
NO.	

ORIGINAL SURVEY	DATE
SURVEYED	BY
NOTE BOOK	
TEMPLATE	
AREAS	
CHECKED	
NO.	

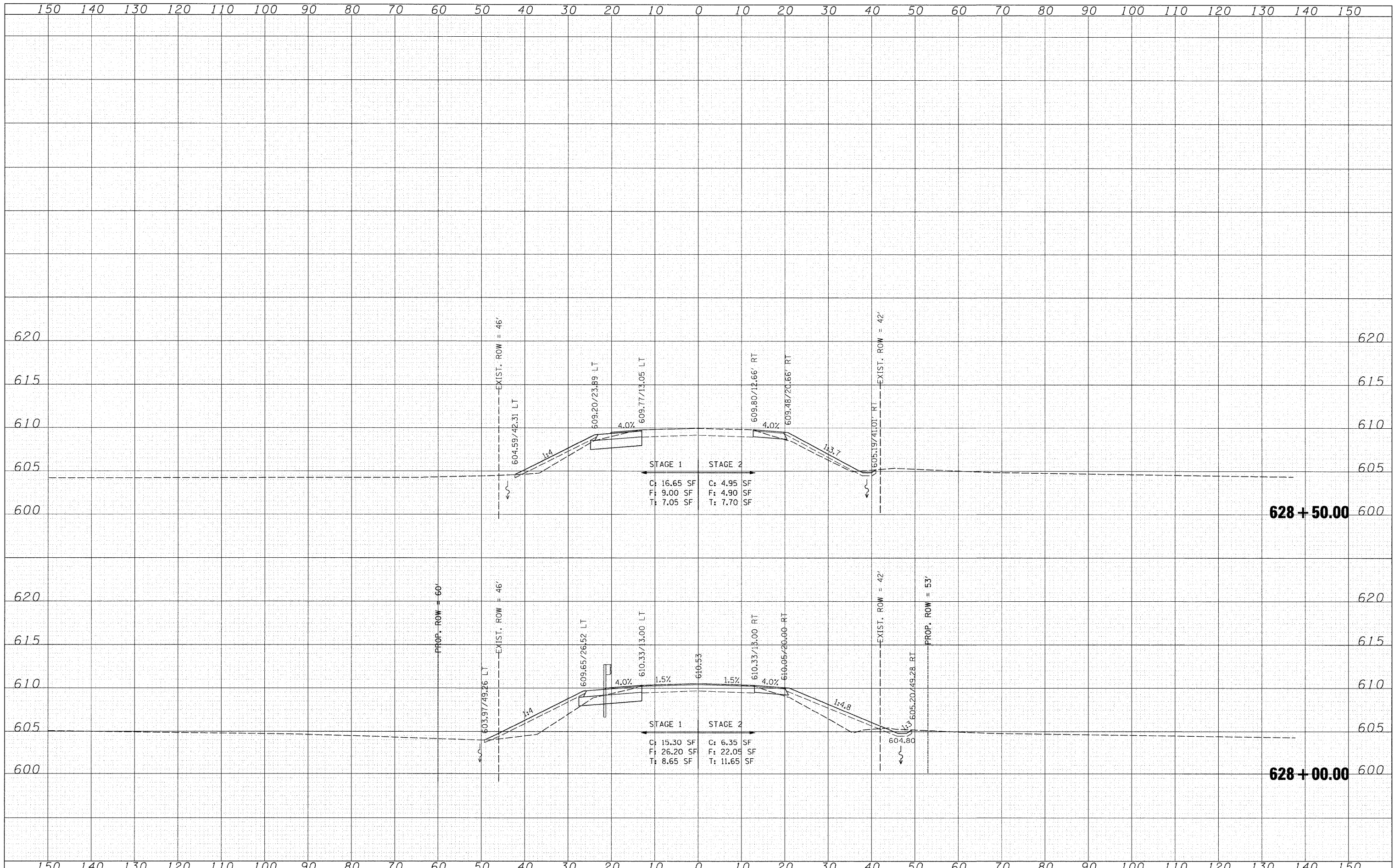

FILE NAME =	USER NAME = brionf
S:\JOL\6300-6399\6346\027\Microsoft\Sh\sh\sh\sh\dgn	
PLOT SCALE = 10.0000' / IN.	
PLOT DATE = 7/19/2011	

DESIGNED VLF	REVISED -
CHECKED RKK	REVISED -
DRAWN VLF	REVISED -
CHECKED RKK	REVISED -

**STATE OF ILLINOIS
DEPARTMENT OF TRANSPORTATION**

CROSS SECTIONS			
S.N. 037-0174			
SCALE:	SHEET NO.	OF SHEETS	STA. 628+00.00 TO STA. 628+50.00

F.A.P. RTE.	SECTION	COUNTY	TOTAL SHEETS	SHEET NO.
585	128 BR	HENRY	106	84
CONTRACT NO. 64C20				
FED. ROAD DIST. NO. 2 ILLINOIS FED. AID PROJECT				

DATE	
BY	
FINAL SURVEY	
SURVEYED	
NOTE BOOK	
TEMPLATE	
AREAS CHECKED	
NO.	

DATE	
BY	
ORIGINAL SURVEY	
SURVEYED	
NOTE BOOK	
TEMPLATE	
AREAS CHECKED	
NO.	

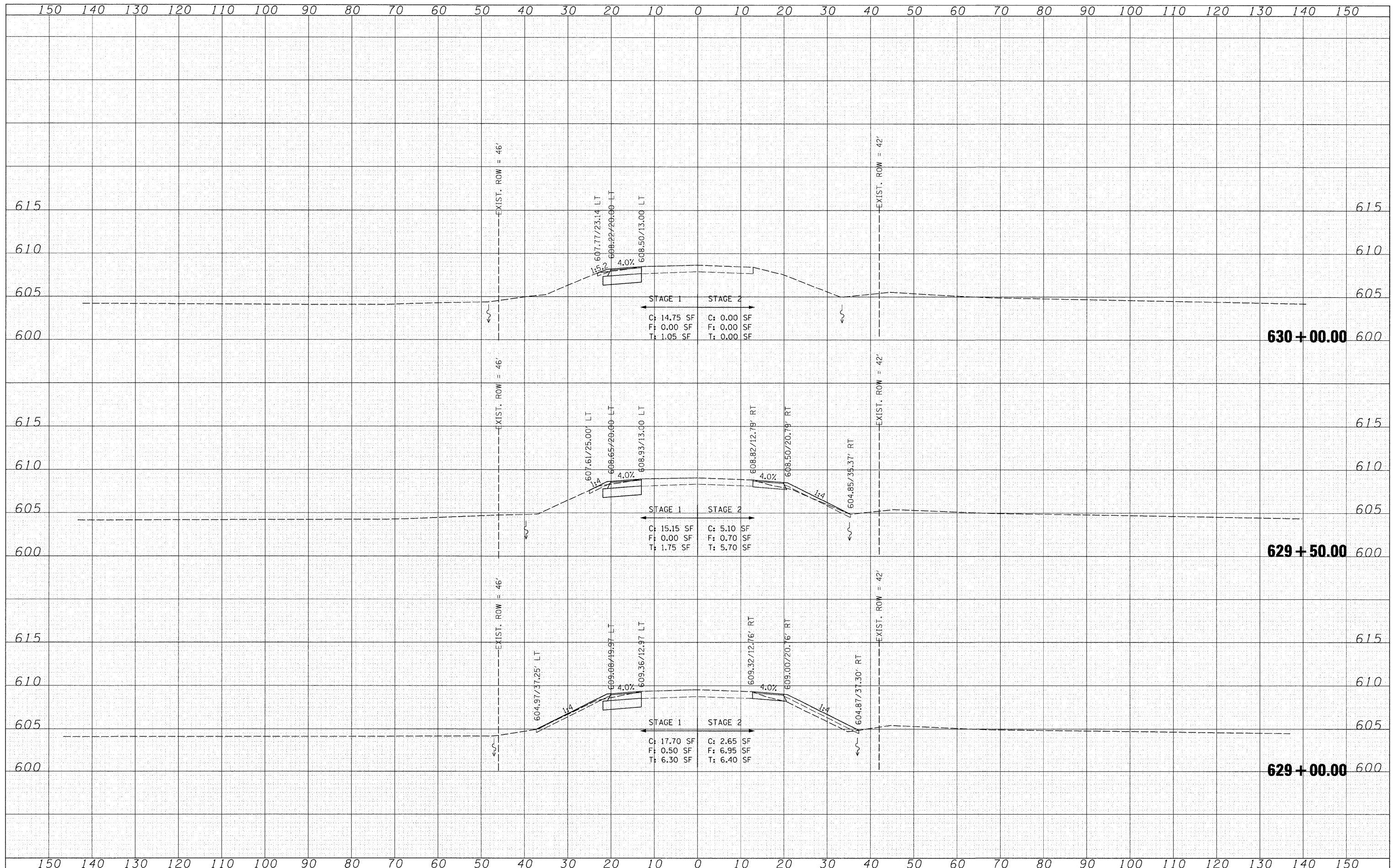

FILE NAME =
 St:\JOL\6300-6399\6346\227\Microsoft\Sh\shht-xssht.dgn

USER NAME = brianf
 DESIGNED -
 CHECKED -
 PLOT SCALE = 18,0000 ' / IN.
 PLOT DATE = 7/19/2011

DESIGNED -
 CHECKED -
 DRAWN -
 CHECKED -

REVISED -
 REVISED -
 REVISED -
 REVISED -

**STATE OF ILLINOIS
 DEPARTMENT OF TRANSPORTATION**

**CROSS SECTIONS
 S.N. 037-0174**

SCALE: SHEET NO. OF SHEETS STA. 629+00.00 TO STA. 630+00.00

F.A.P. RTE. 585	SECTION 128 BR	COUNTY HENRY	TOTAL SHEETS 106	SHEET NO. 85
CONTRACT NO. 64C20				
FED. ROAD DIST. NO. 2 ILLINOIS FED. AID PROJECT				

FINAL SURVEY	DATE
SURVEYED	BY
PLANNED	
TEMPORARY	
NOTE BOOK	
AREAS CHECKED	
NO.	

ORIGINAL SURVEY	DATE
SURVEYED	BY
PLANNED	
TEMPORARY	
NOTE BOOK	
AREAS CHECKED	
NO.	

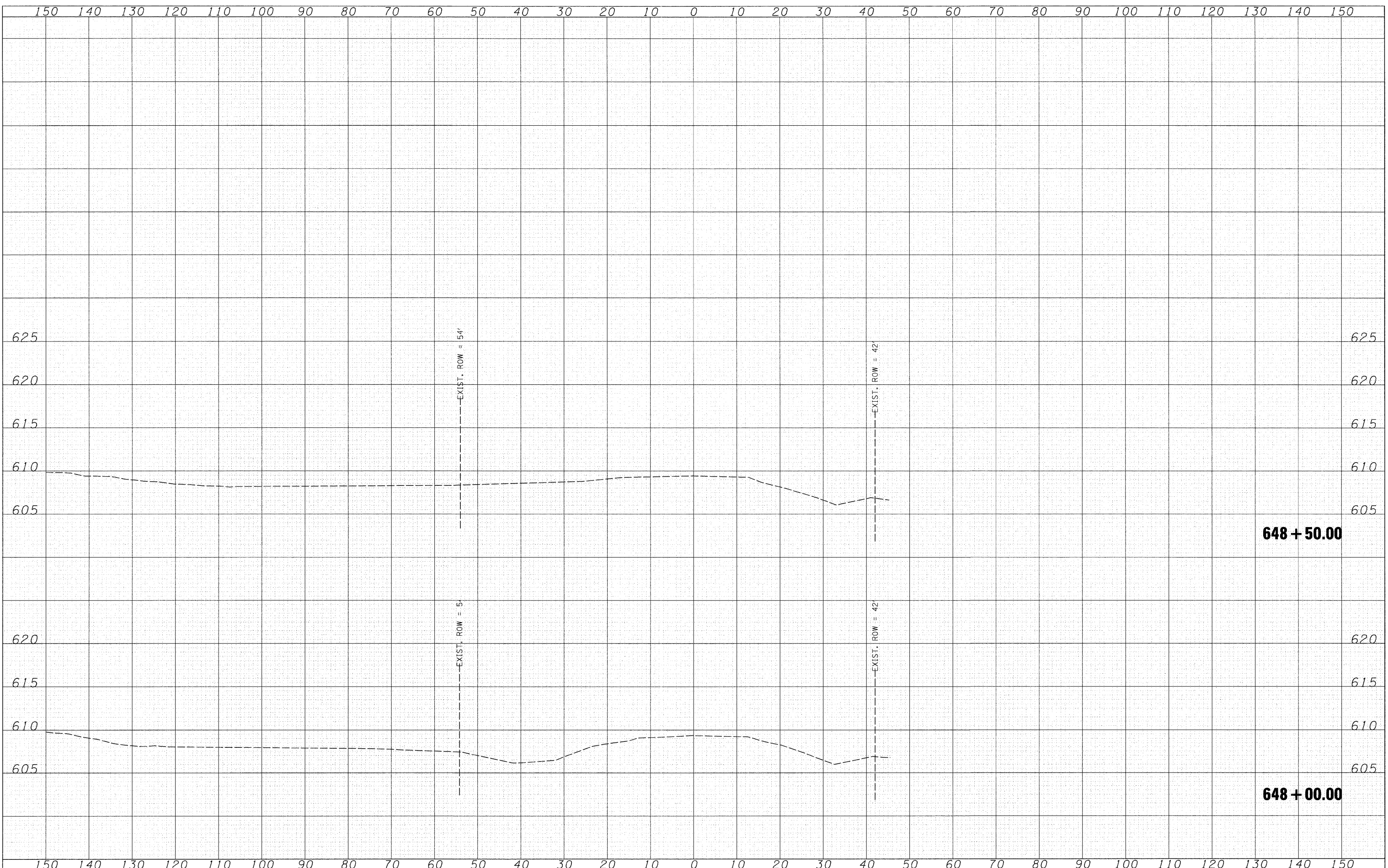

FILE NAME =	USER NAME = brianf	DESIGNED VLF	REVISED -	STATE OF ILLINOIS DEPARTMENT OF TRANSPORTATION	CROSS SECTIONS - CULVERT/DITCH				F.A.P. RTE.	SECTION	COUNTY	TOTAL SHEETS	SHEET NO.
S:\JOL\6300--6399\6346\027\Micros\Sh\sh-xssh.dgn		CHECKED RKK	REVISED -		SCALE:	SHEET NO.	OF	SHEETS	585	128 BR	HENRY	106	86
		DRAWN VLF	REVISED -		STA. 648+00.00	TO	STA. 648+50.00						
		CHECKED RKK	REVISED -		FED. ROAD DIST. NO.		ILLINOIS FED. AID PROJECT		CONTRACT NO. 64C20				

DATE	
BY	
FINAL SURVEY	
NOTE BOOK	
NO. _____	
AREAS CHECKED	

DATE	
BY	
ORIGINAL SURVEY	
NOTE BOOK	
NO. _____	
AREAS CHECKED	

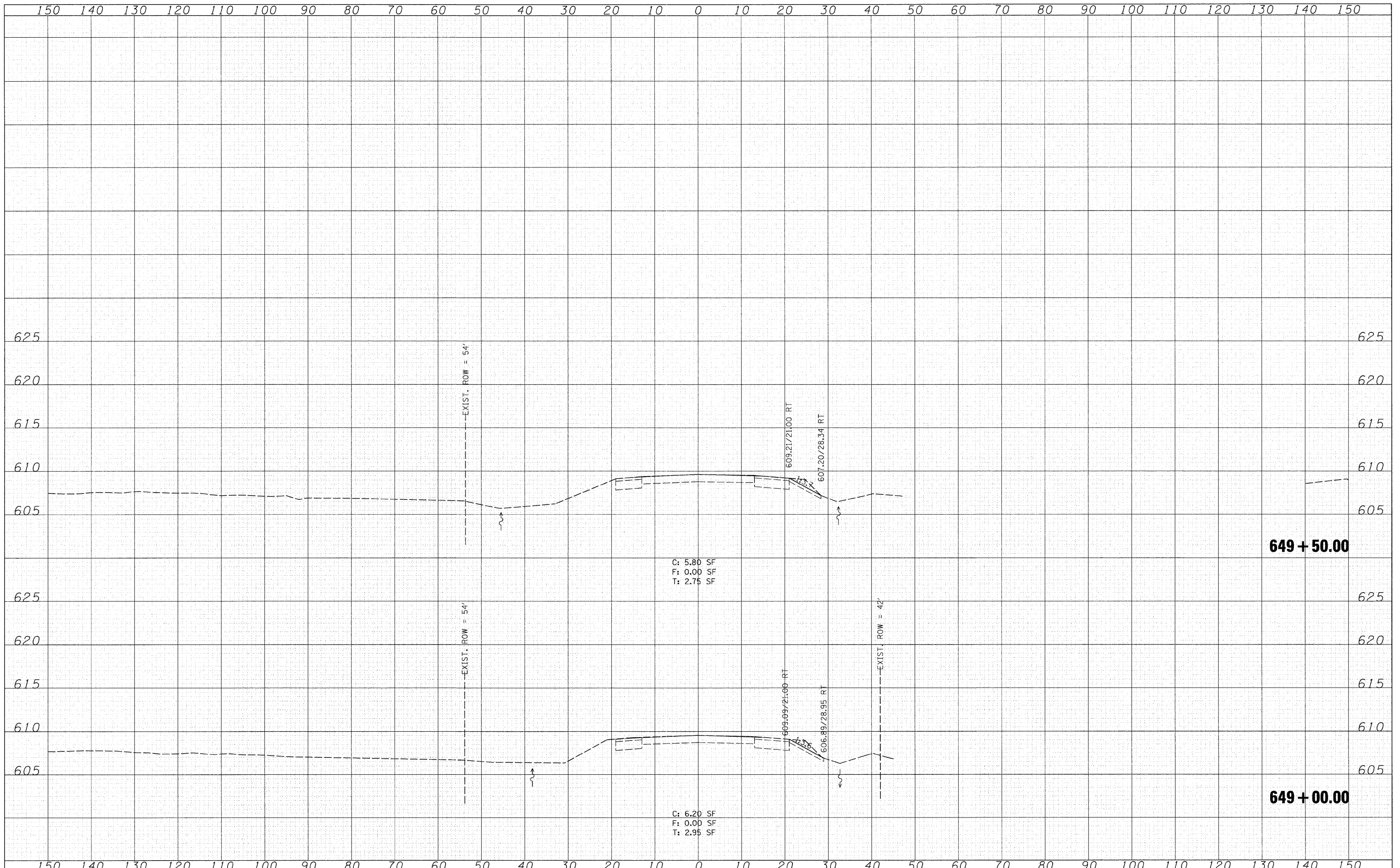

FILE NAME = S:\JOL\6300-6399\6346\027\Micros\Sh\shh\dgn	USER NAME = brianf	DESIGNED VLF	REVISOR -	STATE OF ILLINOIS DEPARTMENT OF TRANSPORTATION	CROSS SECTIONS - CULVERT/DITCH SCALE: SHEET NO. OF SHEETS STA. 649+00.00 TO STA. 649+50.00				F.A.P. RTE. 585	SECTION 128 BR	COUNTY HENRY	TOTAL SHEETS 106	SHEET NO. 87
PLOT SCALE = 10.0000' / IN.	DRAWN VLF	REVISOR -	CONTRACT NO. 64C20										
PLOT DATE = 7/19/2011	CHECKED RKK	REVISOR -	ILLINOIS FED. AID PROJECT										
	CHECKED RKK	REVISOR -											

FINAL SURVEY	DATE
SURVEYED	BY
NOTE BOOK	
TEMPLATE	
AREAS CHECKED	
NO.	

ORIGINAL SURVEY	DATE
SURVEYED	BY
NOTE BOOK	
TEMPLATE	
AREAS CHECKED	
NO.	

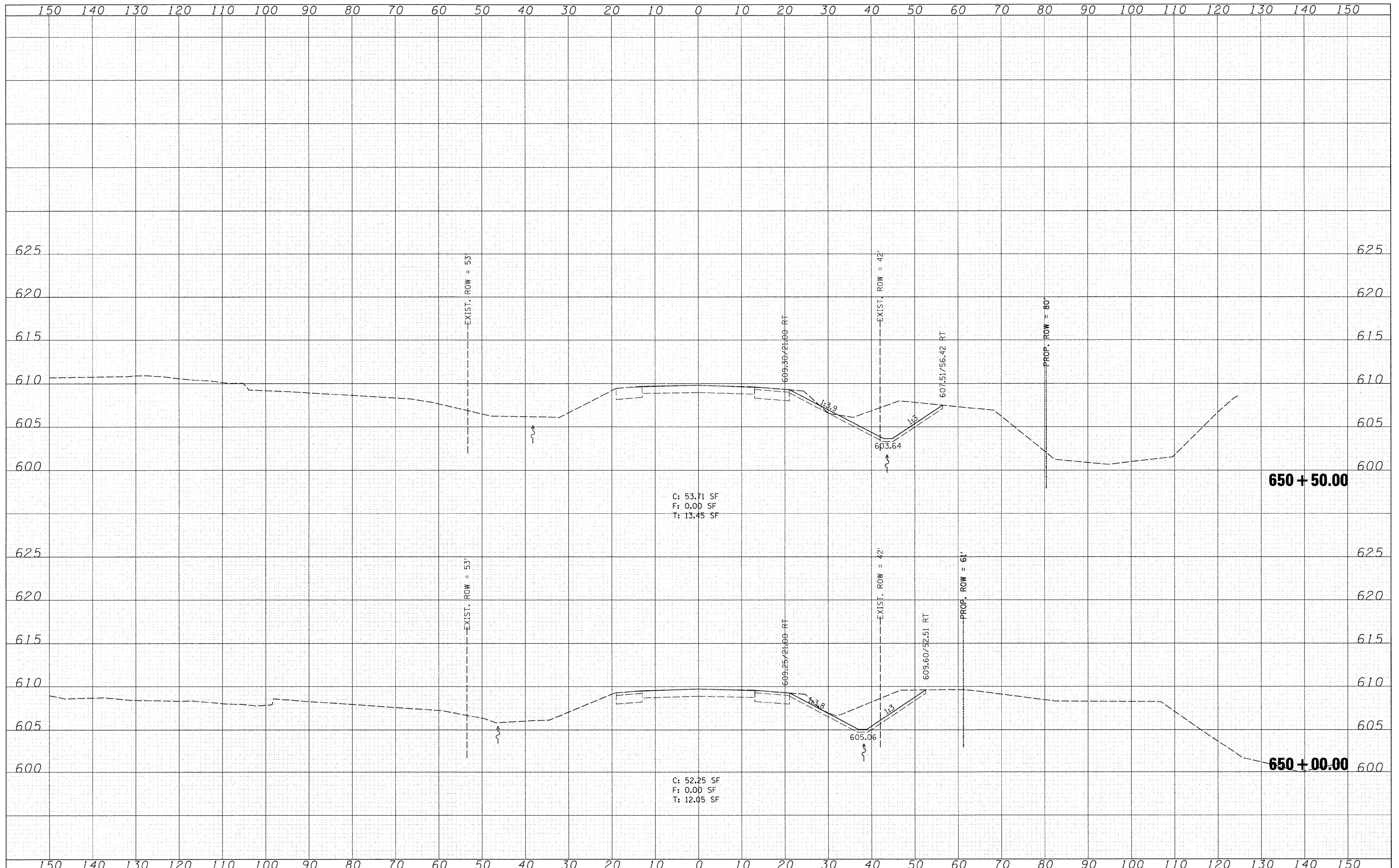

FILE NAME =
 Sr\JOL\6300-6399\6346\027\Microsoft\Sh\sh\ssht\dgn

USER NAME = brtanf
 DESIGNED VLF
 CHECKED RKK
 PLOT SCALE = 10.0000' / IN.
 DRAWN VLF
 PLOT DATE = 7/19/2011
 CHECKED RKK

REVISED -
 REVISED -
 REVISED -
 REVISED -

**STATE OF ILLINOIS
 DEPARTMENT OF TRANSPORTATION**

CROSS SECTIONS - CULVERT/DITCH

SCALE: SHEET NO. OF SHEETS STA. 650+00.00 TO STA. 650+50.00

F.A.P. RTE.	SECTION	COUNTY	TOTAL SHEETS	SHEET NO.
585	128 BR	HENRY	106	88
CONTRACT NO. 64C20			ILLINOIS FED. AID PROJECT	

DATE	
BY	
FINAL SURVEY	
NOTE BOOK	
TEMPLATE	
AREAS CHECKED	
NO.	

DATE	
BY	
ORIGINAL SURVEY	
NOTE BOOK	
TEMPLATE	
AREAS CHECKED	
NO.	

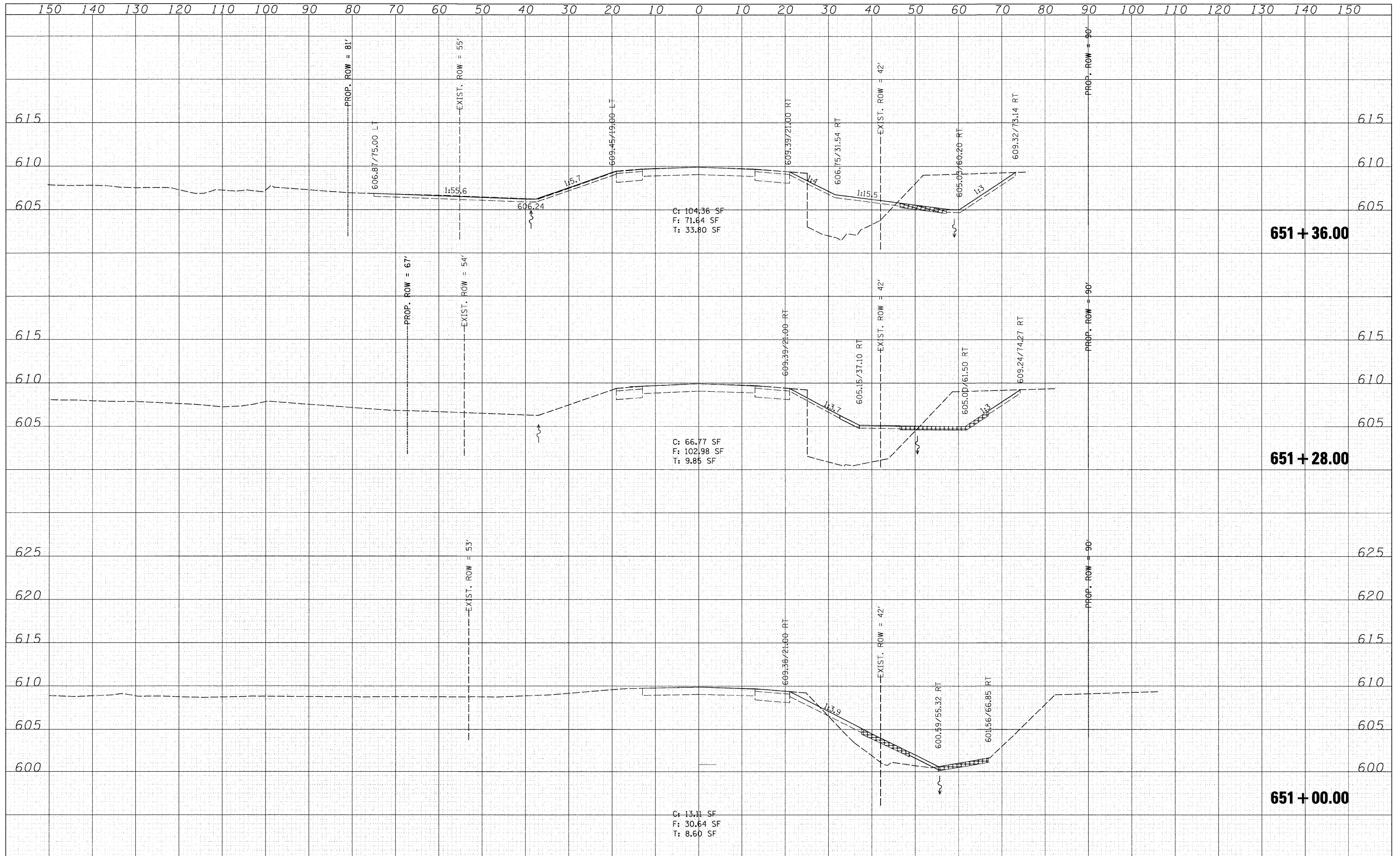

FILE NAME =	USER NAME = br1anf	DESIGNED VLF	REVISED -	STATE OF ILLINOIS DEPARTMENT OF TRANSPORTATION	CROSS SECTIONS - CULVERT/DITCH			F.A.P. RTE.	SECTION	COUNTY	TOTAL SHEETS	SHEET NO.
S:\JDL\6300--6399\6346\027\Microsoft\Sh\ent-xssh\1.dgn	CHECKED RKK	REVISED -	585					128 BR	HENRY	106	89	
PLOT SCALE = 10,0000' / IN.	DRAWN VLF	REVISED -	CONTRACT NO. 64C20									
PLOT DATE = 7/19/2011	CHECKED RKK	REVISED -	ILLINOIS FED. AID PROJECT									
				SCALE:	SHEET NO.	OF	SHEETS	STA. 651+00.00	TO STA. 651+36.00			

FINAL SURVEY	SURVEYED	BY	DATE
NOTE BOOK	TEMPLE		
AREAS	CHECKED		
NO.			

ORIGINAL SURVEY	SURVEYED	BY	DATE
NOTE BOOK	TEMPLE		
AREAS	CHECKED		
NO.			

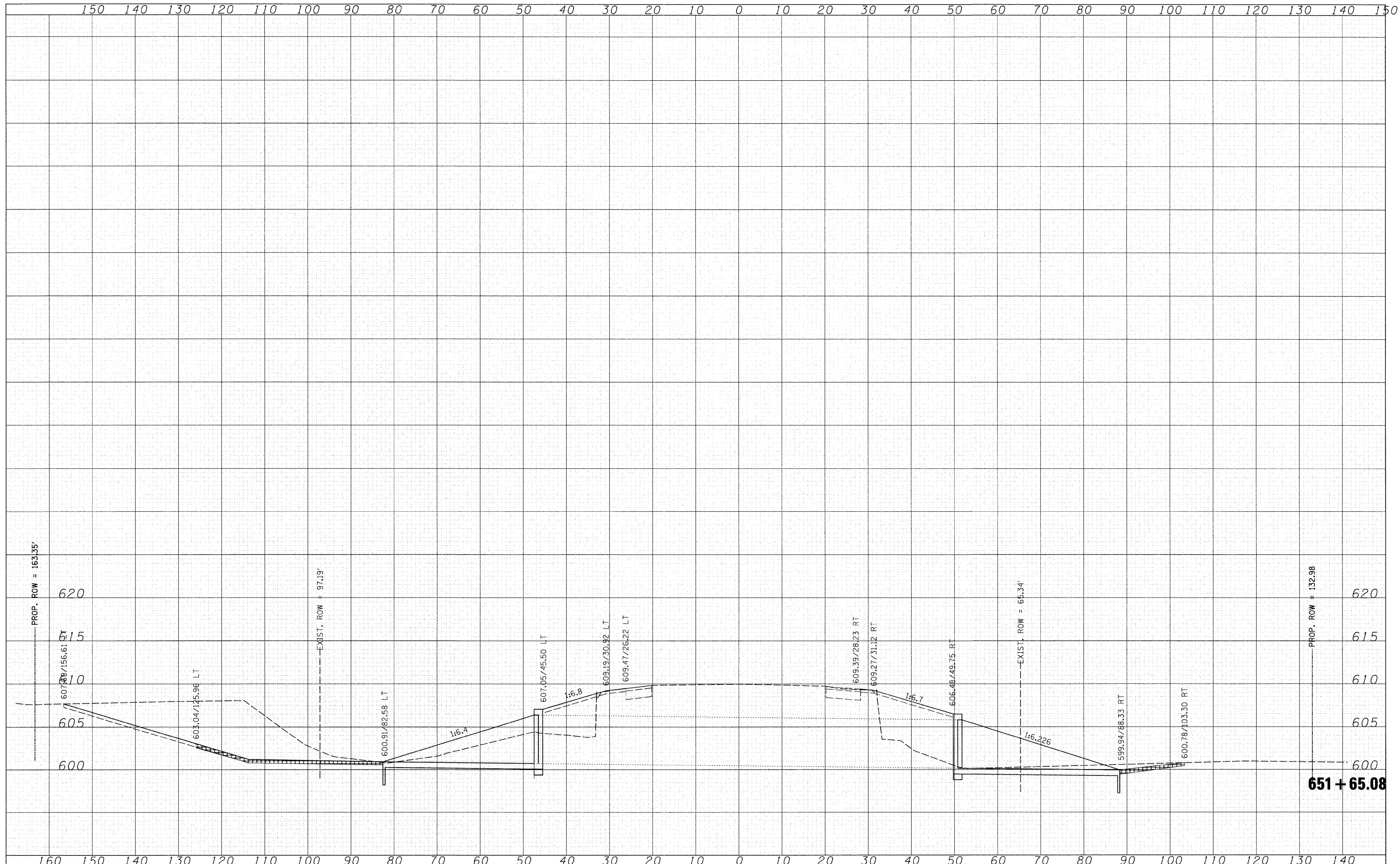

FILE NAME =	USER NAME = brtanf	DESIGNED -	REVISED -	STATE OF ILLINOIS DEPARTMENT OF TRANSPORTATION	CROSS SECTIONS - CULVERT/DITCH				F.A.P. R.T.E.	SECTION	COUNTY	TOTAL SHEETS	SHEET NO.
Sr\JOL\6300-6399\6346\027\Microsoft\Sh\sh\sshd.dgn		CHECKED -	REVISED -		SCALE:	SHEET NO.	OF	SHEETS	STA. 651+65.08	TO STA. 651+65.08	HENRY	106	90
		DRAWN -	REVISED -								CONTRACT NO. 64C20		
		CHECKED -	REVISED -								FED. ROAD DIST. NO. 2	ILLINOIS	FED. AID PROJECT

FINAL SURVEY	SURVEYED	DATE
NOTE BOOK	TEMPLATE	BY
AREAS CHECKED	AREAS CHECKED	
NO.		

ORIGINAL SURVEY	SURVEYED	DATE
NOTE BOOK	TEMPLATE	BY
AREAS CHECKED	AREAS CHECKED	
NO.		

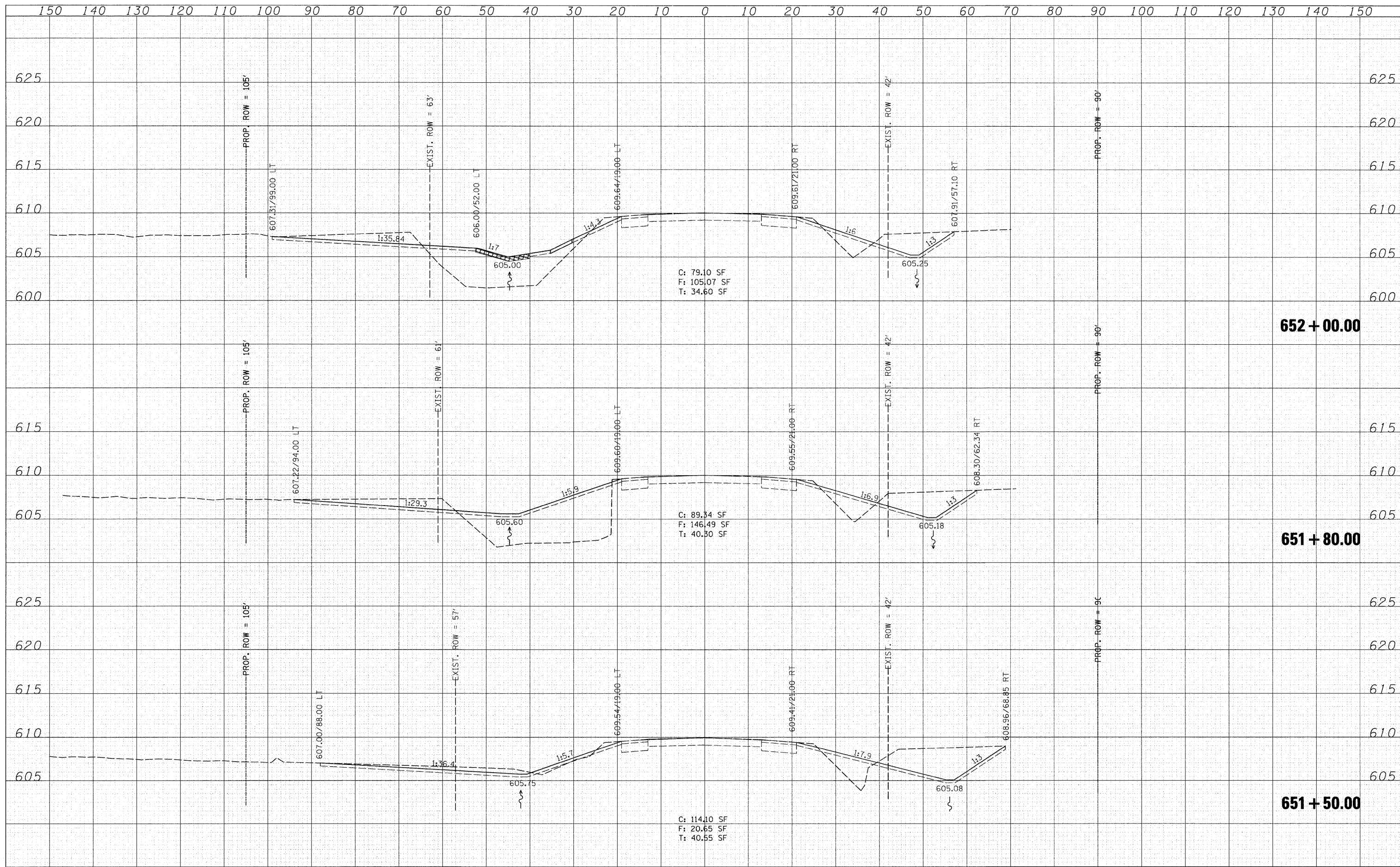

FILE NAME = S:\JDL\6302-6399\6346\027\Micro\Sh\sh\sshd.dgn	USER NAME = brnanf	DESIGNED VLF	REVISED -	STATE OF ILLINOIS DEPARTMENT OF TRANSPORTATION	CROSS SECTIONS - CULVERT/DITCH			F.A.P. RTE. 585	SECTION 128 BR	COUNTY HENRY	TOTAL SHEETS 106	SHEET NO. 91	
PLOT SCALE = 10.0000' / IN.	DRAWN VLF	REVISED -	CONTRACT NO. 64C20										
PLOT DATE = 7/19/2011	CHECKED RKK	REVISED -	SCALE: SHEET NO. OF SHEETS STA. 651+50.00 TO STA. 652+00.00										
								ILLINOIS FED. AID PROJECT					

DATE	
BY	
FINAL SURVEY	
SURVEYED	
NOTE BOOK	
TEMPLATE	
AREAS	
CHECKED	
NO.	

DATE	
BY	
ORIGINAL SURVEY	
SURVEYED	
NOTE BOOK	
TEMPLATE	
AREAS	
CHECKED	
NO.	

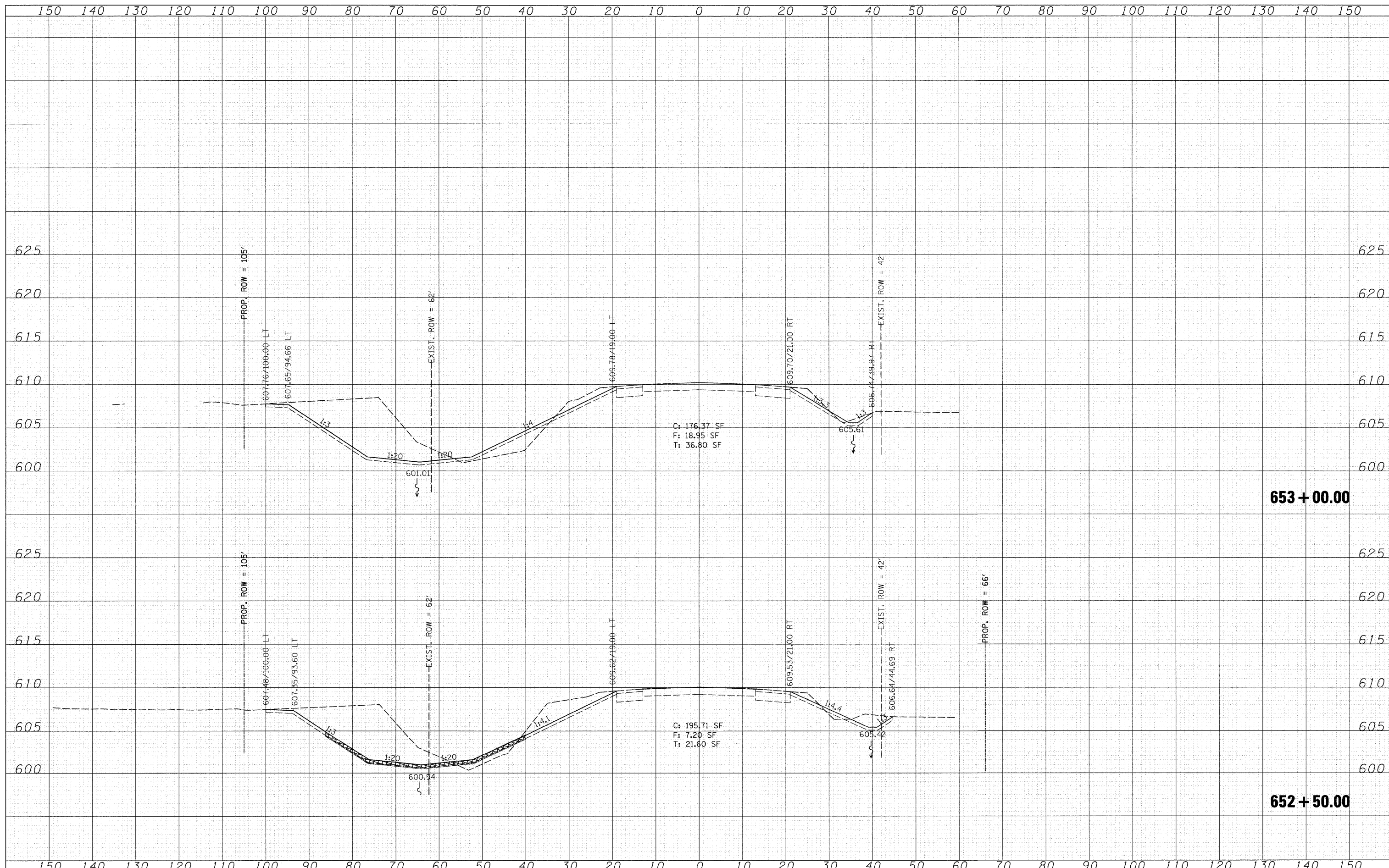

FILE NAME = S:\JUL\6300--6399\6346\027\Micros\Sh\shht-xssht.dgn

USER NAME = brionf
 PLOT SCALE = 10,0000 ' / IN.
 PLOT DATE = 7/19/2011

DESIGNED VLF
 CHECKED RKK
 DRAWN VLF
 CHECKED RKK

REVISED -
 REVISED -
 REVISED -
 REVISED -

**STATE OF ILLINOIS
 DEPARTMENT OF TRANSPORTATION**

CROSS SECTIONS - CULVERT/DITCH

SCALE: SHEET NO. OF SHEETS STA. 652+50.00 TO STA. 653+00.00

F.A.P. RTE.	SECTION	COUNTY	TOTAL SHEETS	SHEET NO.
585	128 BR	HENRY	106	92
CONTRACT NO. 64C20				
FED. ROAD DIST. NO. ILLINOIS FED. AID PROJECT				

FINAL	SURVEYED	DATE
SURVEY	TEMPLATE	BY
NOTE BOOK	AREAS	CHECKED
NO.		

ORIGINAL	SURVEYED	DATE
SURVEY	TEMPLATE	BY
NOTE BOOK	AREAS	CHECKED
NO.		

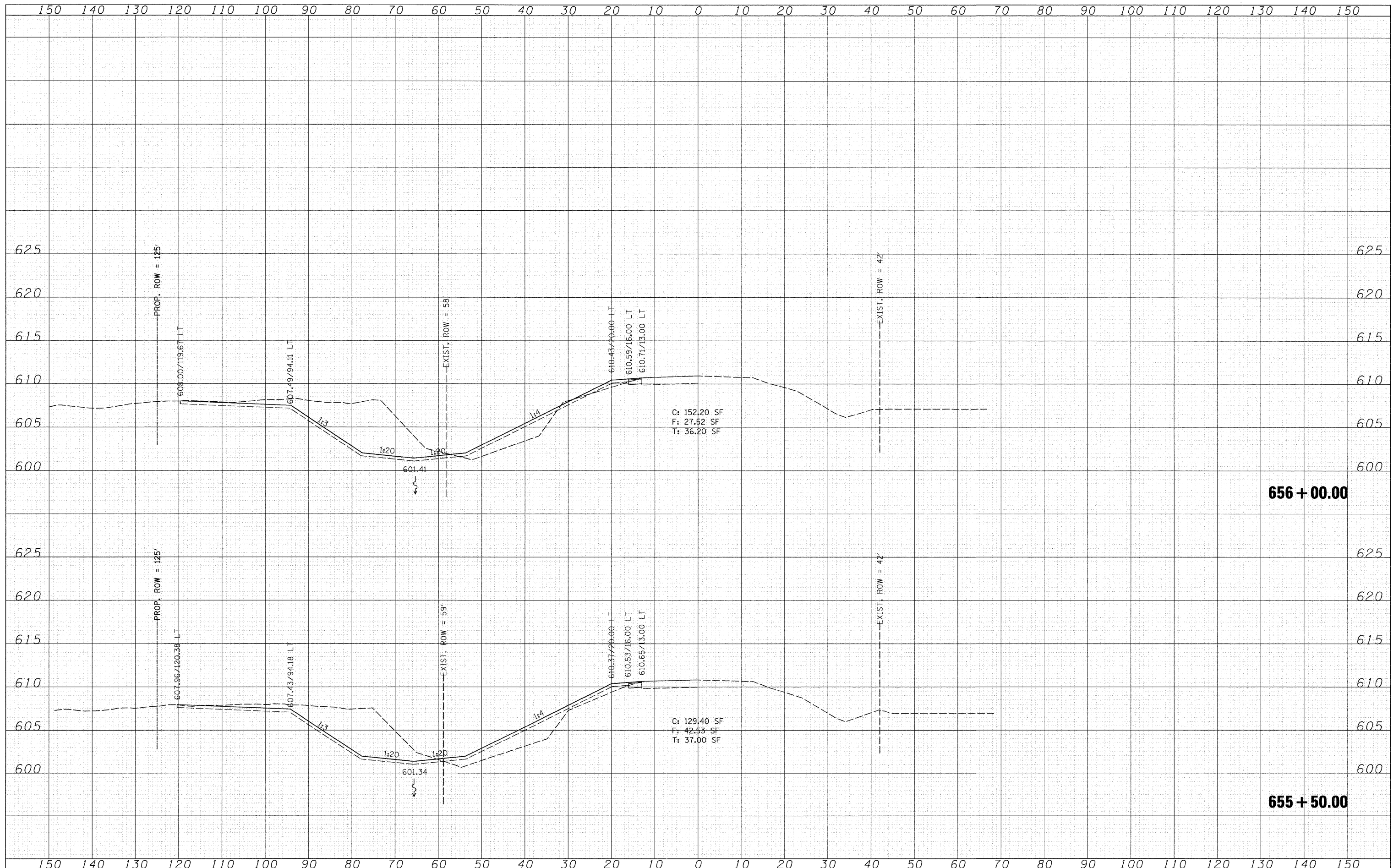

FILE NAME =
 Sr:\JOL\6300-6399\6346\027\Micors\Sh\shht-xssh\dgn

USER NAME = brianf
 PLOT SCALE = 10.0000' / IN.
 PLOT DATE = 7/19/2011

DESIGNED VLF
 CHECKED RKK
 DRAWN VLF
 CHECKED RKK

REVISED -
 REVISED -
 REVISED -
 REVISED -

**STATE OF ILLINOIS
 DEPARTMENT OF TRANSPORTATION**

CROSS SECTIONS - CULVERT/DITCH

SCALE: SHEET NO. OF SHEETS STA. 655+50.00 TO STA. 656+00.00

F.A.P. RTE. 585	SECTION 128 BR	COUNTY HENRY	TOTAL SHEETS 106	SHEET NO. 95
CONTRACT NO. 64C20				
ILLINOIS FED. AID PROJECT				

FINAL SURVEY	SURVEYED	BY	DATE
NOTE BOOK	TEMPLATE		
AREAS	CHECKED		
NO.			

ORIGINAL SURVEY	SURVEYED	BY	DATE
NOTE BOOK	TEMPLATE		
AREAS	CHECKED		
NO.			

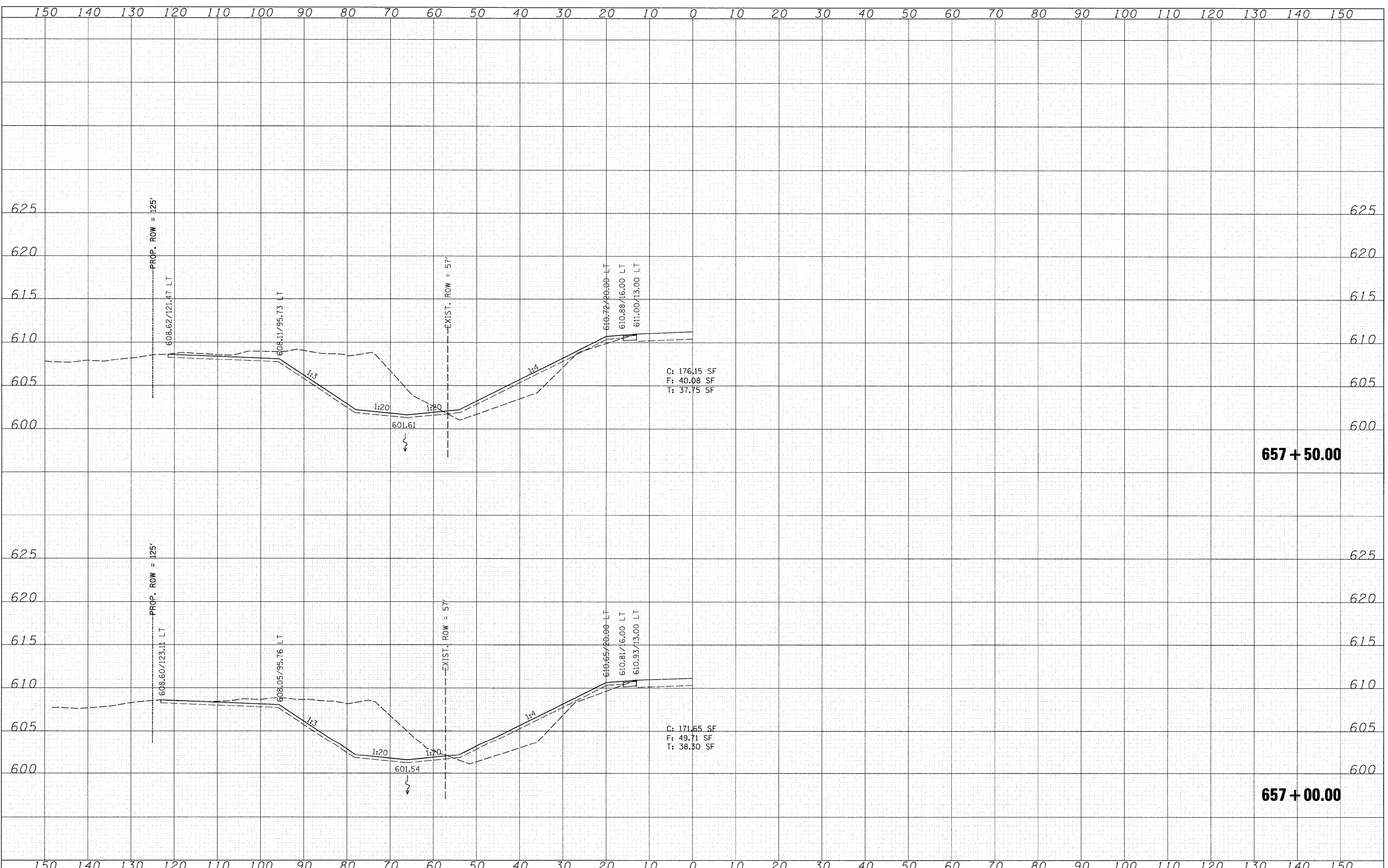

FILE NAME =
 Str:\JUL\6300--6399\6346\227\Micros\Sh\shht-xssht.dgn

USER NAME = brianf
 PLOT SCALE = 10.0000' / IN.
 PLOT DATE = 7/19/2011

DESIGNED VLF
 CHECKED RKK
 DRAWN VLF
 CHECKED RKK

REVISED -
 REVISED -
 REVISED -
 REVISED -

**STATE OF ILLINOIS
 DEPARTMENT OF TRANSPORTATION**

CROSS SECTIONS - CULVERT/DITCH

SCALE: SHEET NO. OF SHEETS STA. 657+00.00 TO STA. 657+50.00

F.A.P. RTE.	SECTION	COUNTY	TOTAL SHEETS	SHEET NO.
585	128 BR	HENRY	106	97
CONTRACT NO. 64C20				
FED. ROAD DIST. NO.		ILLINOIS FED. AID PROJECT		

FINAL SURVEY	DATE
SURVEYED	BY
NOTE BOOK	
TEMPLATE	
AREAS	
CHECKED	
NO.	

ORIGINAL SURVEY	DATE
SURVEYED	BY
NOTE BOOK	
TEMPLATE	
AREAS	
CHECKED	
NO.	

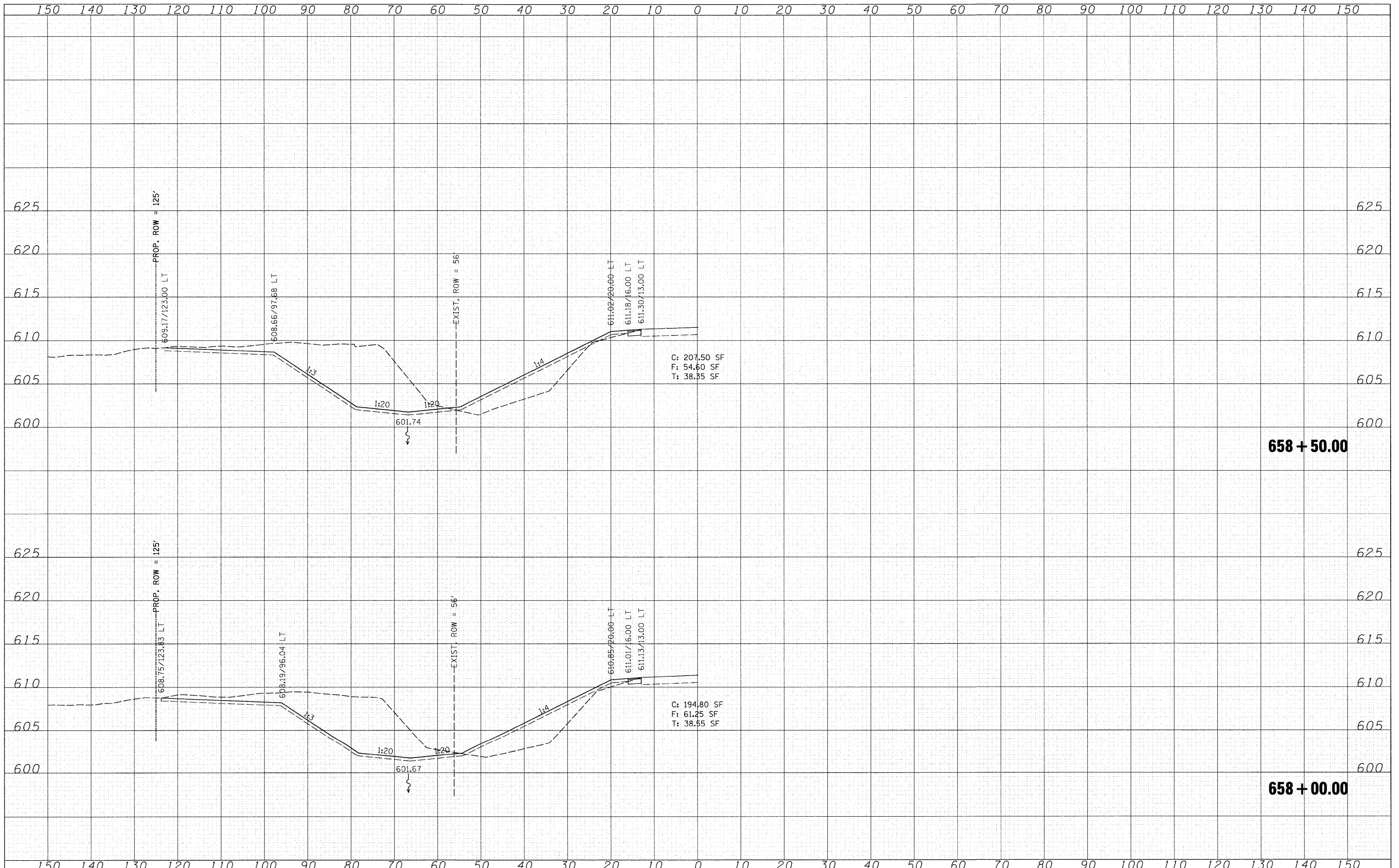

FILE NAME =	USER NAME = brtanf	DESIGNED VLF	REVISED -
S:\JOL\6300-6399\6346\027\Moros\Sh\shht-vssht.dgn		CHECKED RKK	REVISED -
PLOT SCALE = 10.0000' / IN.		DRAWN VLF	REVISED -
PLOT DATE = 7/19/2011		CHECKED RKK	REVISED -

**STATE OF ILLINOIS
DEPARTMENT OF TRANSPORTATION**

CROSS SECTIONS - CULVERT/DITCH			
SCALE:	SHEET NO.	OF SHEETS	STA. 658+00.00 TO STA. 658+50.00

F.A.P. RTE.	SECTION	COUNTY	TOTAL SHEETS	SHEET NO.
585	128 BR	HENRY	106	98
CONTRACT NO. 64C20				
FED. ROAD DIST. NO.		ILLINOIS FED. AID PROJECT		

DATE	
BY	
FINISHED SURVEY	
NOTE BOOK	
NO.	
TEMPLATES	
AREAS CHECKED	

DATE	
BY	
ORIGINAL SURVEY	
NOTE BOOK	
NO.	
TEMPLATES	
AREAS CHECKED	

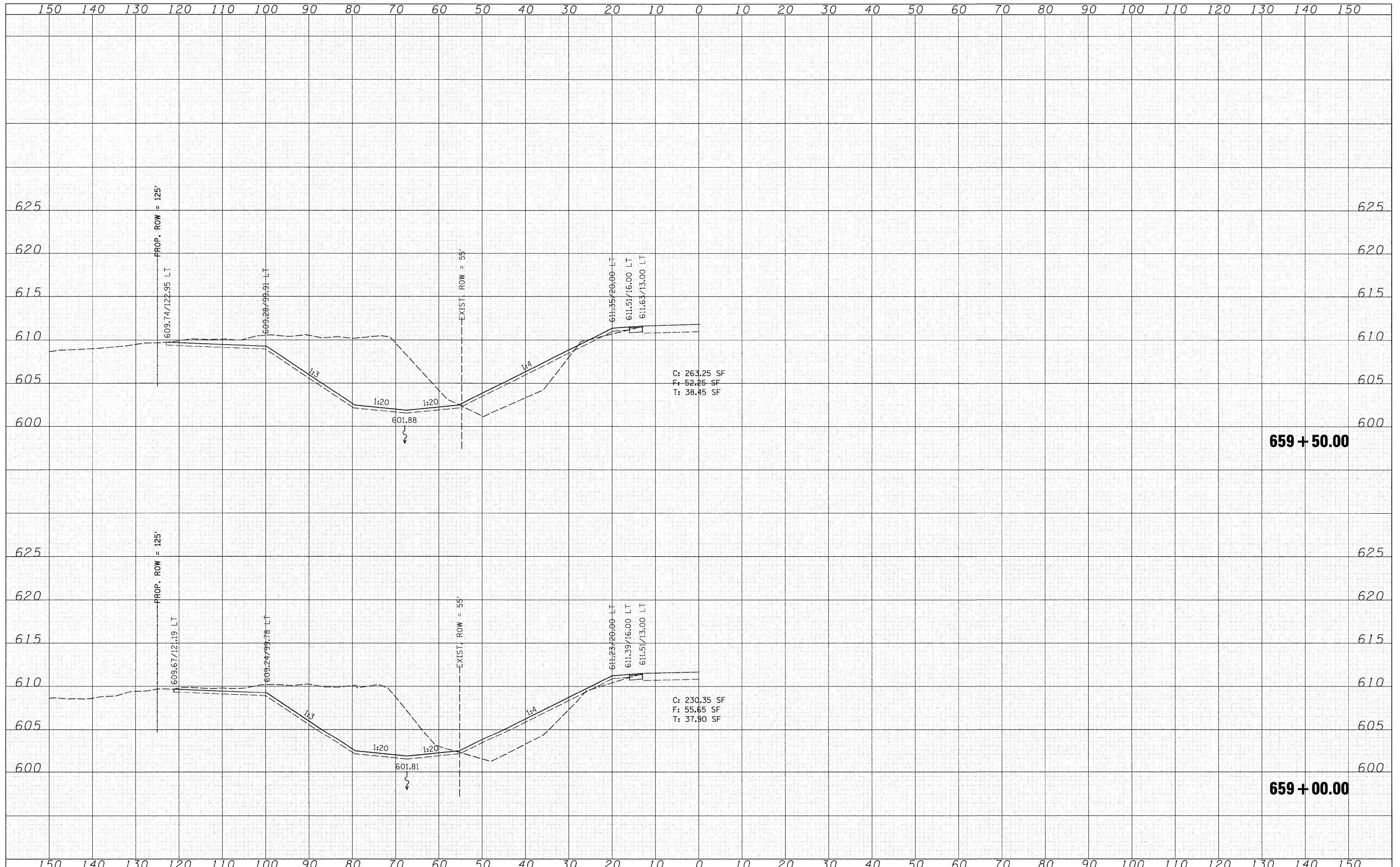

FILE NAME =	USER NAME = brianf
S:\JUL\6300-6399\6346\027\Microsoft\Sh\sh\sh\dgn	
PLOT SCALE = 10,0000' / IN.	
PLOT DATE = 7/19/2011	

DESIGNED	VLF	REVISED	-
CHECKED	RKK	REVISED	-
DRAWN	VLF	REVISED	-
CHECKED	RKK	REVISED	-

**STATE OF ILLINOIS
DEPARTMENT OF TRANSPORTATION**

CROSS SECTIONS - CULVERT/DITCH			
SCALE:	SHEET NO.	OF	SHEETS
			STA. 659+00.00 TO STA. 659+50.00

F.A.P. RTE.	SECTION	COUNTY	TOTAL SHEETS	SHEET NO.
585	128 BR	HENRY	106	99
CONTRACT NO. 64C20				
FED. ROAD DIST. NO. ILLINOIS FED. AID PROJECT				

FINAL SURVEY	DATE
SURVEYED	BY
NOTE BOOK	
TEMPLATE	
AREAS CHECKED	
NO.	

ORIGINAL SURVEY	DATE
SURVEYED	BY
NOTE BOOK	
TEMPLATE	
AREAS CHECKED	
NO.	

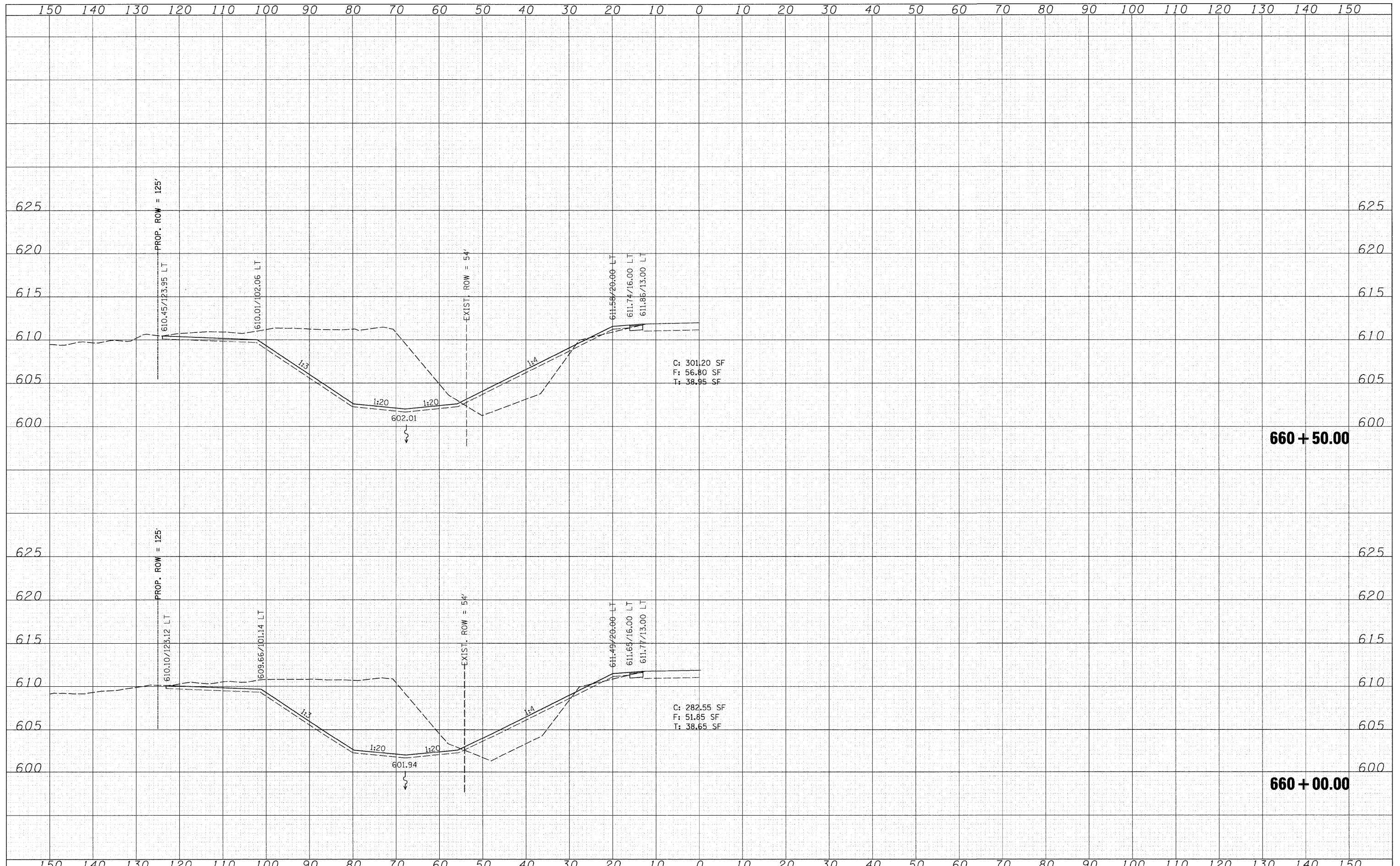

FILE NAME =	USER NAME = brianf
S:\JUL\6300-6399\6346\027\Micros\Shit\shh-xshh.dgn	
PLOT SCALE = 10.0000' / IN.	
PLOT DATE = 7/19/2011	

DESIGNED	VLF	REVISED	-
CHECKED	RKK	REVISED	-
DRAWN	VLF	REVISED	-
CHECKED	RKK	REVISED	-

STATE OF ILLINOIS
DEPARTMENT OF TRANSPORTATION

CROSS SECTIONS - CULVERT/DITCH			
SCALE:	SHEET NO.	OF	SHEETS
			STA. 660+00.00 TO STA. 660+50.00

F.A.P. RTE.	SECTION	COUNTY	TOTAL SHEETS	SHEET NO.
585	128 BR	HENRY	106	100
CONTRACT NO. 64C20				
FED. ROAD DIST. NO.		ILLINOIS FED. AID PROJECT		

STATE OF ILLINOIS DEPARTMENT OF TRANSPORTATION				
CROSS SECTIONS - CULVERT/DITCH				
SCALE: SHEET NO. OF SHEETS STA. 660+00.00 TO STA. 660+50.00				
F.A.P. RTE. SECTION COUNTY TOTAL SHEETS SHEET NO.				
585 128 BR HENRY 106 100				
CONTRACT NO. 64C20				
FED. ROAD DIST. NO.		ILLINOIS FED. AID PROJECT		

FINAL SURVEY	SURVEYED	BY	DATE
NOTE BOOK	TEMPLATE		
AREAS	CHECKED		
NO.			

ORIGINAL SURVEY	SURVEYED	BY	DATE
NOTE BOOK	TEMPLATE		
AREAS	CHECKED		
NO.			

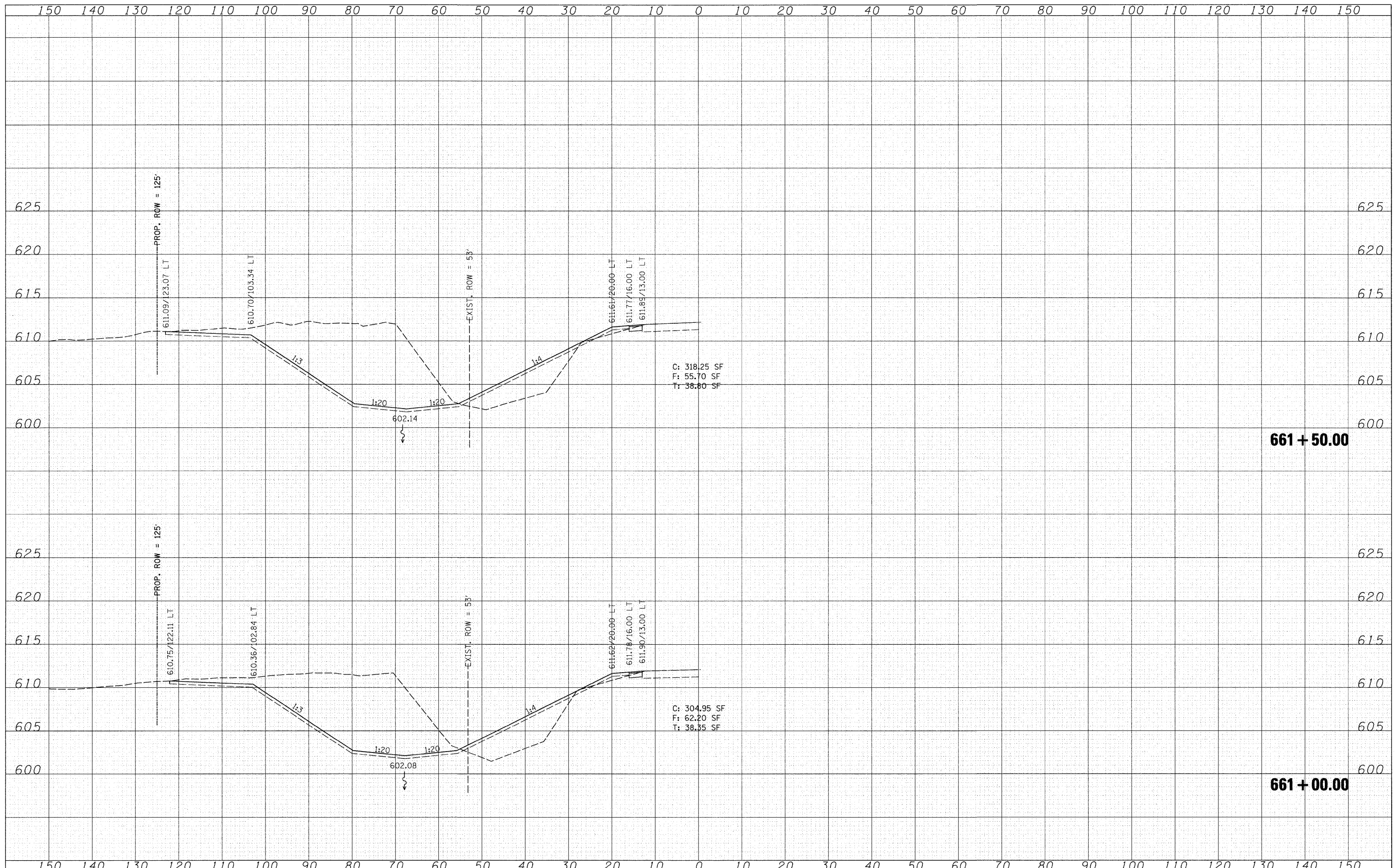

C: 318.25 SF
F: 55.70 SF
T: 38.80 SF

C: 304.95 SF
F: 62.20 SF
T: 38.35 SF

661 + 50.00

661 + 00.00

FILE NAME = Sr:\JOL\6300--6399\6346\027\1010as\Sh\shht-xssht.dgn
PLOT SCALE = 10.0000' / IN.
PLOT DATE = 7/19/2011

USER NAME = brianf
DESIGNED VLF
CHECKED RKK
DRAWN VLF
CHECKED RKK

DESIGNED VLF
CHECKED RKK
DRAWN VLF
CHECKED RKK

REVISED -
REVISED -
REVISED -
REVISED -

**STATE OF ILLINOIS
DEPARTMENT OF TRANSPORTATION**

CROSS SECTIONS - CULVERT/DITCH

SCALE: SHEET NO. OF SHEETS STA. 661+00.00 TO STA. 661+50.00

F.A.P. RTE.	SECTION	COUNTY	TOTAL SHEETS	SHEET NO.
585	128 BR	HENRY	106	101
CONTRACT NO. 64C20				
ILLINOIS FED. AID PROJECT				

FINAL SURVEY	DATE
SURVEYED	BY
NOTE BOOK	
TEMPLATE	
AREAS	
CHECKED	
NO.	

ORIGINAL SURVEY	DATE
SURVEYED	BY
NOTE BOOK	
TEMPLATE	
AREAS	
CHECKED	
NO.	

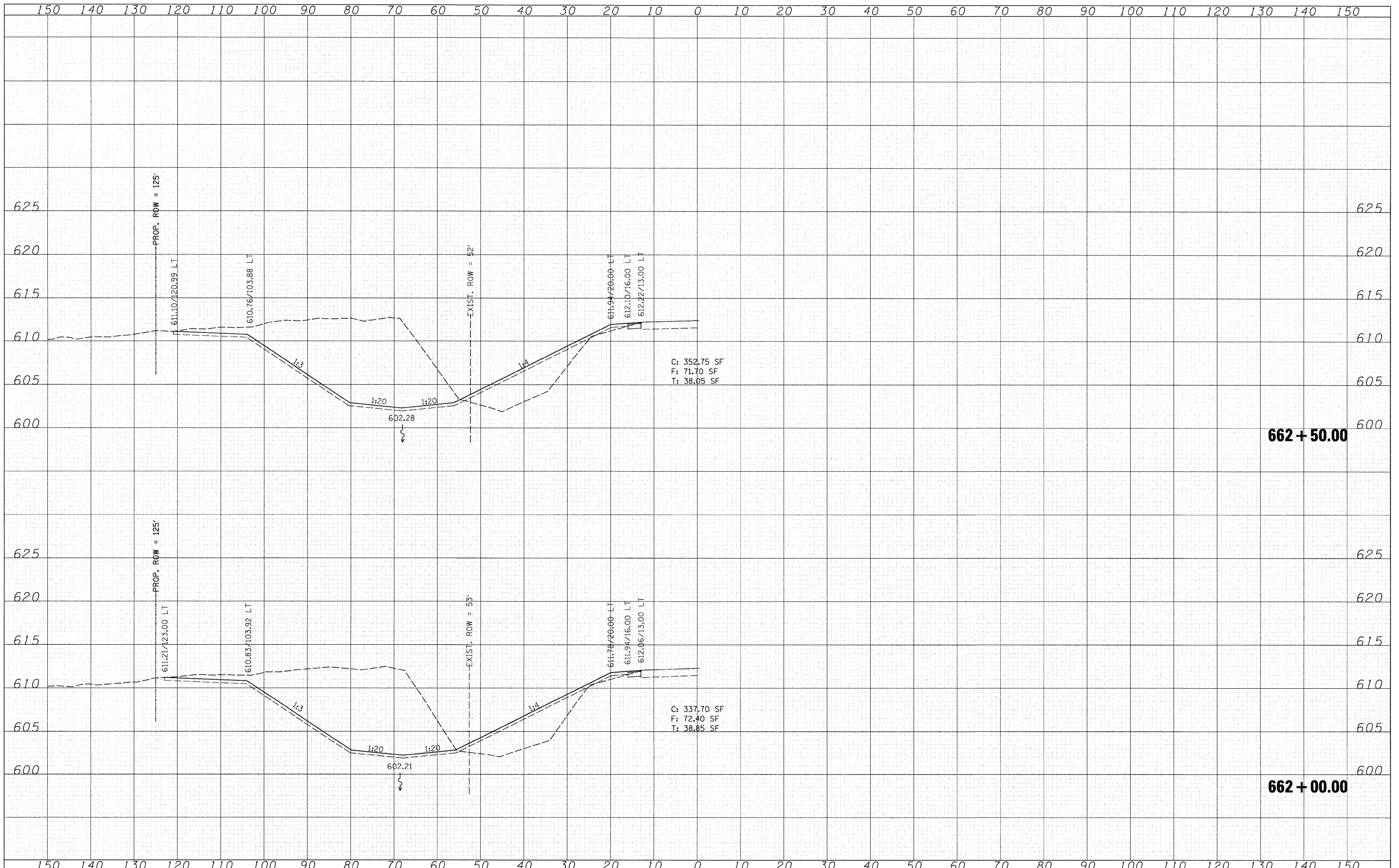

FILE NAME = S:\JUL\6300-6399\6346\027\Micros\Sh\sh-xsshd.dgn
 USER NAME = brionf
 PLOT SCALE = 10.0000' / IN.
 PLOT DATE = 7/19/2011

DESIGNED VLF
 CHECKED RKK
 DRAWN VLF
 CHECKED RKK

REVISED -
 REVISED -
 REVISED -
 REVISED -

**STATE OF ILLINOIS
 DEPARTMENT OF TRANSPORTATION**

CROSS SECTIONS - CULVERT/DITCH
 SCALE: SHEET NO. OF SHEETS STA. 662+00.00 TO STA. 662+50.00

F.A.P. RTE. 585	SECTION 128 BR	COUNTY HENRY	TOTAL SHEETS 106	SHEET NO. 102
FED. ROAD DIST. NO. ILLINOIS FED. AID PROJECT			CONTRACT NO. 64C20	

FINAL SURVEY	SURVEYED	BY	DATE
NOTE BOOK	PLOTTED		
AREAS CHECKED	TEMPLATE		
NO.	AREAS CHECKED		

ORIGINAL SURVEY	SURVEYED	BY	DATE
NOTE BOOK	PLOTTED		
AREAS CHECKED	TEMPLATE		
NO.	AREAS CHECKED		

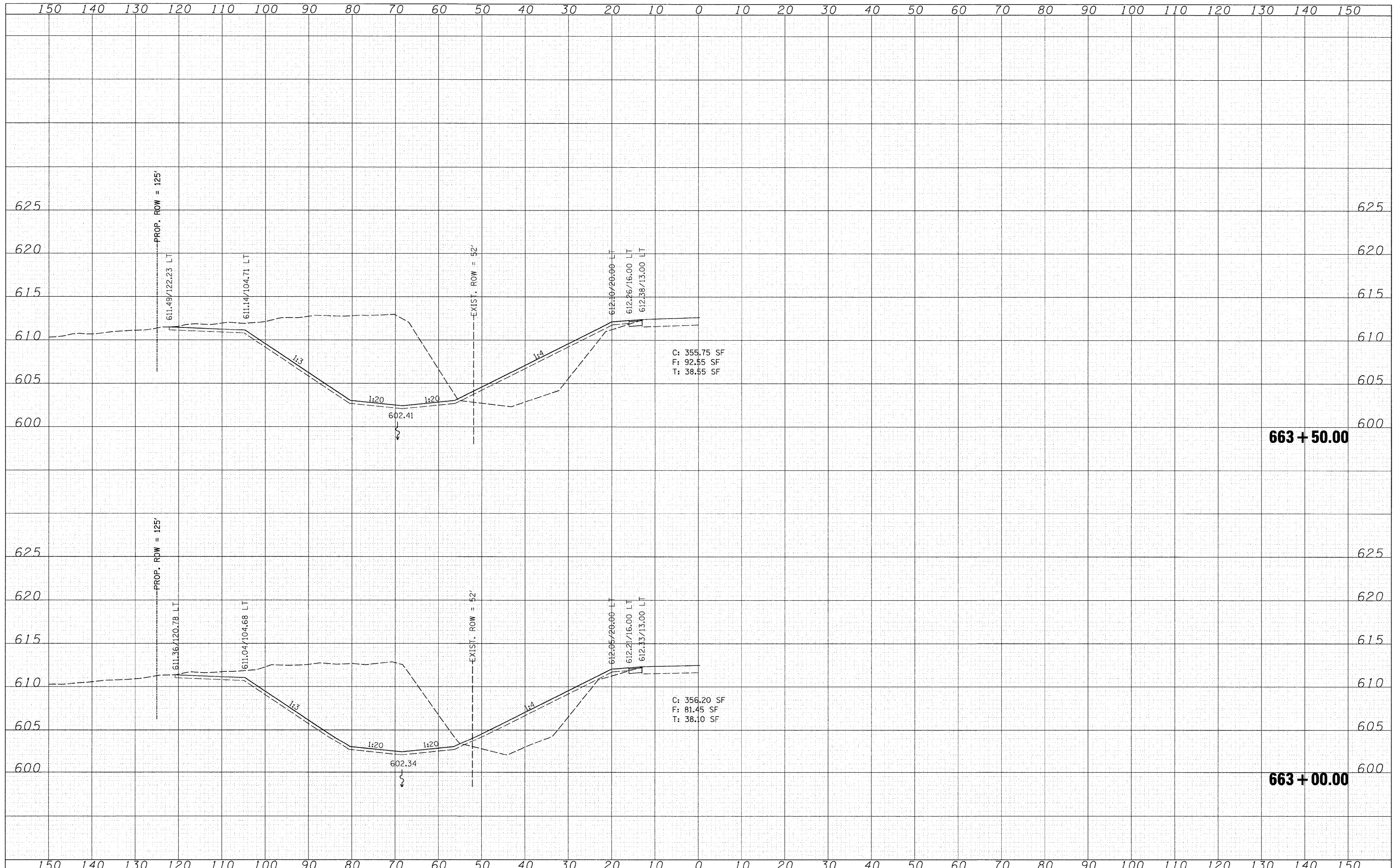

FILE NAME = Sr\JUL\6300-6399\6346\027\Micros\Sh\shht-xssht.dgn

USER NAME = brnanf
 PLOT SCALE = 10.0000' / IN.
 PLOT DATE = 7/19/2011

DESIGNED VLF
 CHECKED RKK
 DRAWN VLF
 CHECKED RKK

REVISED -
 REVISED -
 REVISED -
 REVISED -

**STATE OF ILLINOIS
 DEPARTMENT OF TRANSPORTATION**

CROSS SECTIONS - CULVERT/DITCH

SCALE: SHEET NO. OF SHEETS STA. 663+00.00 TO STA. 663+50.00

F.A.P. RTE.	SECTION	COUNTY	TOTAL SHEETS	SHEET NO.
585	128 BR	HENRY	106	103
CONTRACT NO. 64C20				
FED. ROAD DIST. NO. ILLINOIS FED. AID PROJECT				

BY	DATE
SURVEYED	
PLOTTED	
TEMPLATE	
NOTE BOOK	
AREAS	
CHECKED	
NO.	

BY	DATE
SURVEYED	
PLOTTED	
TEMPLATE	
NOTE BOOK	
AREAS	
CHECKED	
NO.	

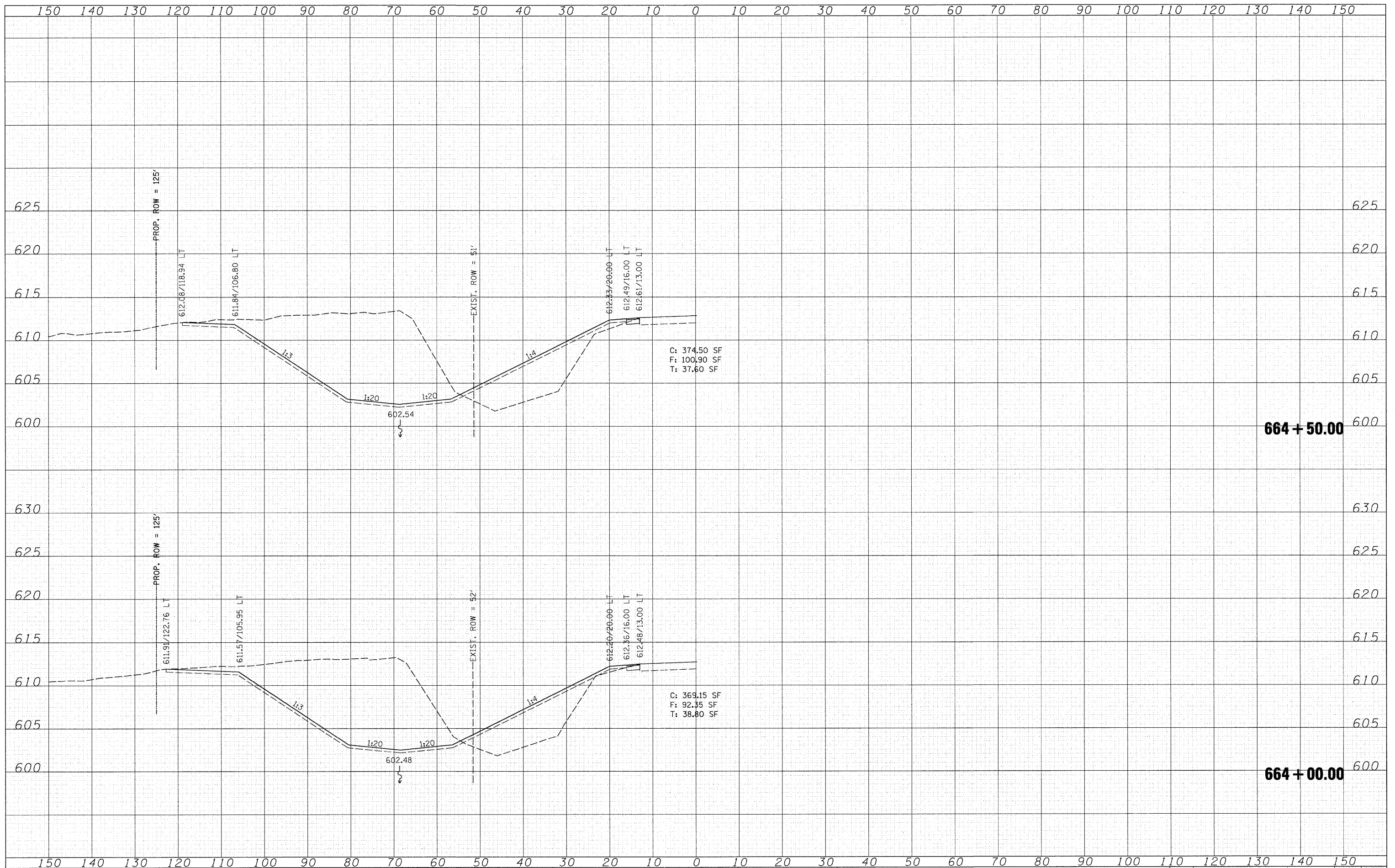

FILE NAME = Sr\JDL\6302-6399\6346\027\Micros\Sh\shht-xssht.dgn
 USER NAME = branf

PLOT SCALE = 10,0000' / IN.
 PLOT DATE = 7/19/2011

DESIGNED VLF
 CHECKED RKK
 DRAWN VLF
 CHECKED RKK

REVISED -
 REVISED -
 REVISED -
 REVISED -

**STATE OF ILLINOIS
 DEPARTMENT OF TRANSPORTATION**

CROSS SECTIONS - CULVERT/DITCH

SCALE: SHEET NO. OF SHEETS STA. 664+00.00 TO STA. 664+50.00

F.A.P. RTE. 585	SECTION 128 BR	COUNTY HENRY	TOTAL SHEETS 106	SHEET NO. 104
FED. ROAD DIST. NO.			ILLINOIS FED. AID PROJECT	
CONTRACT NO. 64C20				

FINAL SURVEY	SURVEYED	DATE
NOTE BOOK	NOTED	BY
AREAS CHECKED	TEMPLATE	
NO.	AREAS	

ORIGINAL SURVEY	SURVEYED	DATE
NOTE BOOK	NOTED	BY
AREAS CHECKED	TEMPLATE	
NO.	AREAS	

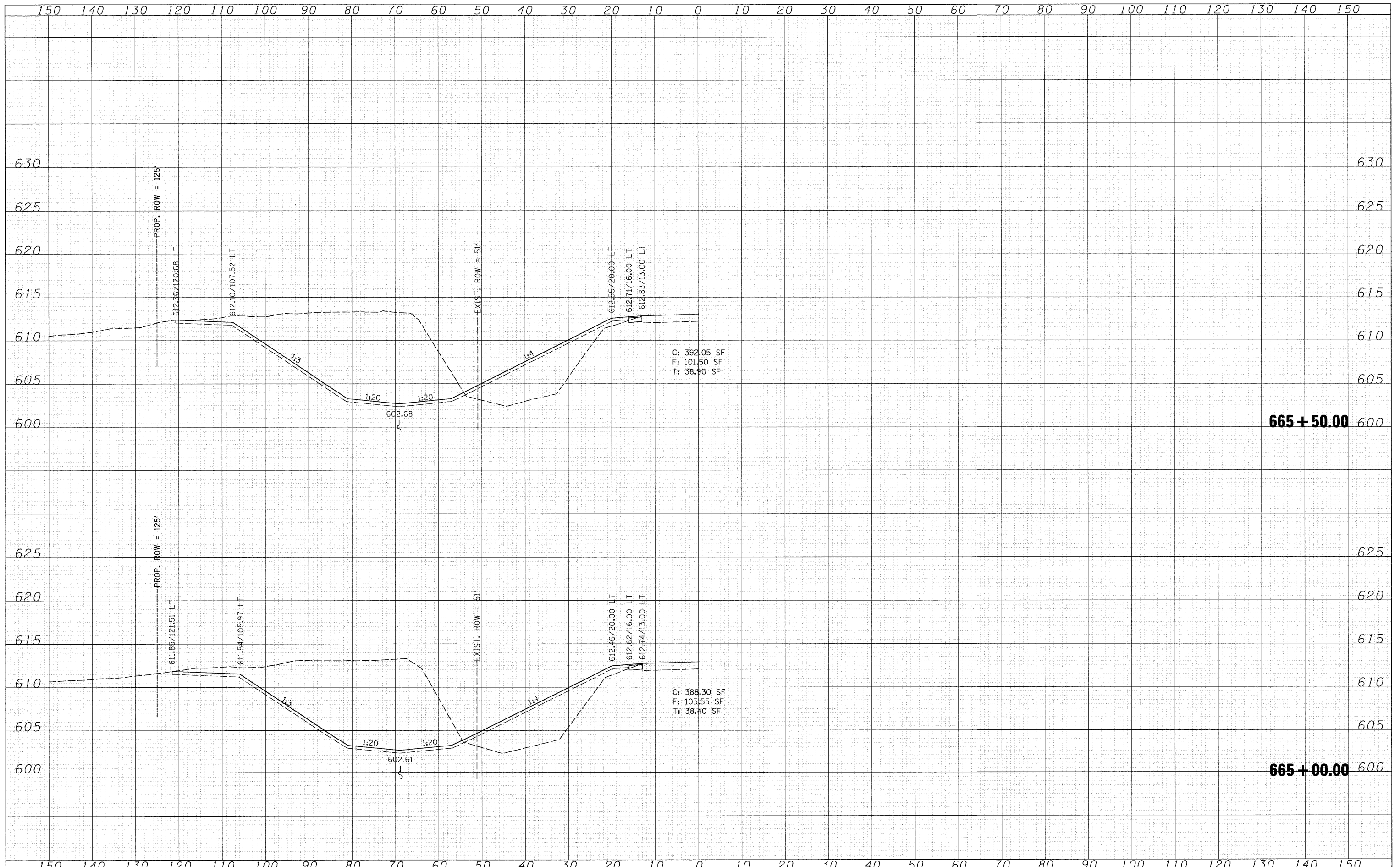

C: 392.05 SF
F: 101.50 SF
T: 38.90 SF

C: 388.30 SF
F: 105.55 SF
T: 38.40 SF

FILE NAME =	USER NAME = brianf	DESIGNED VLF	REVISED -	STATE OF ILLINOIS DEPARTMENT OF TRANSPORTATION	CROSS SECTIONS - CULVERT/DITCH				F.A.P. RTE.	SECTION	COUNTY	TOTAL SHEETS	SHEET NO.
S:\JOL\6300--6399\6346\027\Microsoft\Sh\sh\sh\dgn	CHECKED RKK	REVISED -	REVISED -						585	128 BR	HENRY	106	105
PLOT SCALE = 10,0000' / IN.	DRAWN VLF	REVISED -	REVISED -		CONTRACT NO. 64C20								
PLOT DATE = 7/19/2011	CHECKED RKK	REVISED -	REVISED -		SCALE:	SHEET NO.	OF	SHEETS	STA. 665+00.00 TO STA. 665+50.00	FED. ROAD DIST. NO.	ILLINOIS FED. AID PROJECT		

FINAL SURVEY	SURVEYED	DATE
NOTE BOOK	BY	
NO.		
AREAS CHECKED		

ORIGINAL SURVEY	SURVEYED	DATE
NOTE BOOK	BY	
NO.		
AREAS CHECKED		

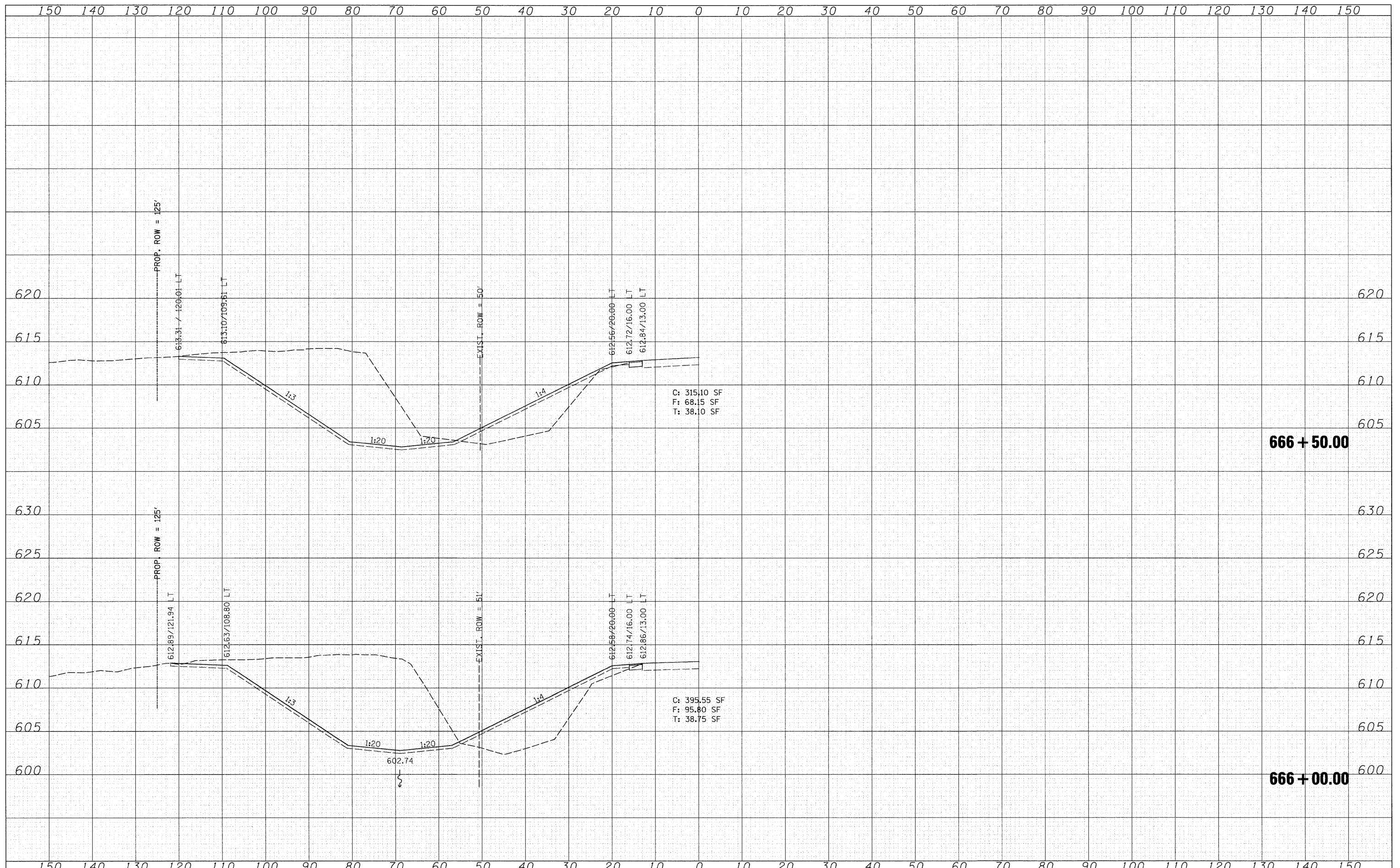

FILE NAME = S:\JDL\6300-6399\6346\027\Micro\Sh\shh\shh.dgn
 USER NAME = brionf
 PLOT SCALE = 10,0000 ' / IN.
 PLOT DATE = 7/19/2011

DESIGNED	VLF	REVISED	-
CHECKED	RKK	REVISED	-
DRAWN	VLF	REVISED	-
CHECKED	RKK	REVISED	-

**STATE OF ILLINOIS
DEPARTMENT OF TRANSPORTATION**

CROSS SECTIONS - CULVERT/DITCH

SCALE: SHEET NO. OF SHEETS STA. 666+00.00 TO STA. 667+00.00

F.A.P. RTE.	SECTION	COUNTY	TOTAL SHEETS	SHEET NO.
585	128 BR	HENRY	106	106
CONTRACT NO. 64C20				
FED. ROAD DIST. NO. ILLINOIS FED. AID PROJECT				