

DROP BOX NO. 1

RT STA. 23+03

GENERAL NOTES

This work shall be paid for at the contract unit price per Each for Drop Box No. 1. This work shall be done according to the applicable portion of 503, 508, and 540 of the Standard Specifications. Contractor shall field verify Galvanized pipe length. Exposed edges shall be beveled 3/4". Reinforcement bars shall conform to the requirements of ASTM A 706 Gr. 60. All steel pipe shall be standard weight (Sch. 40) unless otherwise noted. All components of the Steel Pipe Grate System shall be galvanized according to the requirements of AASHTO M 111 or M 232 as applicable. Fabrication of the steel Pipe Grate System shall conform to the requirements in Section 505 of the Standard Specifications unless noted otherwise. Structural steel shapes and plates shall conform to the requirements of Article 1006.04 of the Standard Specifications. Steel pipes shall conform to the requirements of ASTM A 53 (Type E or S), Grade B. Anchor rods shall conform to the min. strength requirements of ASTM F1554, Grade 105. Anchor rods shall be drilled and epoxy grouted according to the requirements of Section 584 of the Standard Specifications, except as shown. Bolts shall conform to the requirements of Article 1006.08 of the Standard Specifications. The minimum edge distance from the center of a hole to the free edge of a structural shape or plate shall be 1 1/2" unless noted otherwise. Bolts and anchor rods shall be snug tightened by a few impacts of an impact wrench or the full force of a worker using an ordinary spud wrench. All cost associated with furnishing and installing the steel Pipe Grate system shall be included in the contract unit price of Each for Drop Box No. 1. All excavation/backfilling required for construction of the drop box as shown in these plans and in accordance with the Standard Specifications shall be included in the cost of Drop Box No. 1. 12" ϕ & 18" ϕ field tiles will be incorporated into the construction of the drop box wall. See detail. Precast alternate is allowed. See Plan & Profile Sheet for more information. See Cross Section Sheet for more information.

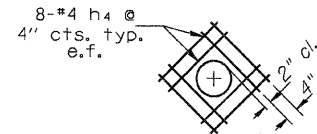

DETAIL FOR FIELD TILE
(Maximum 18" ϕ)

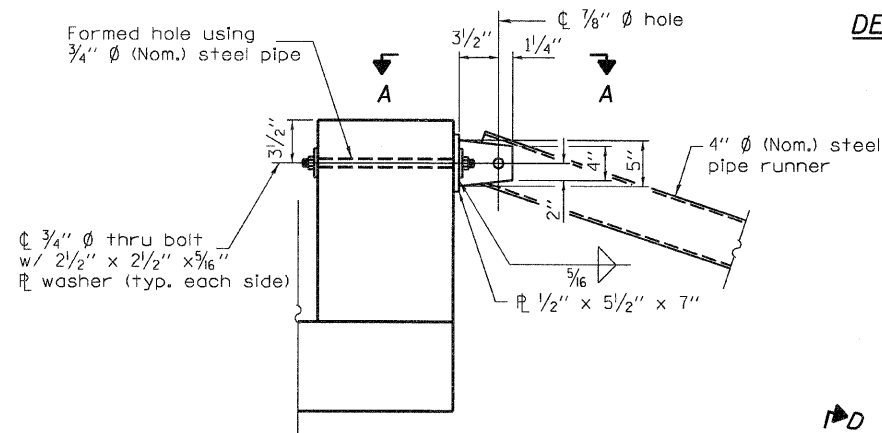

DETAIL A

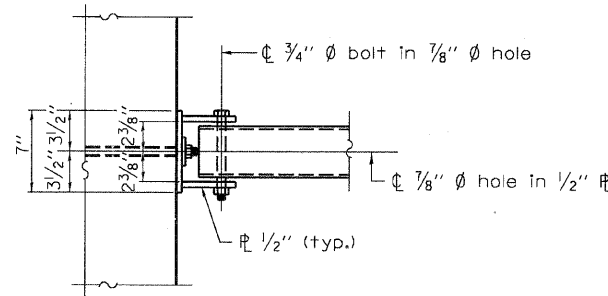

VIEW A-A

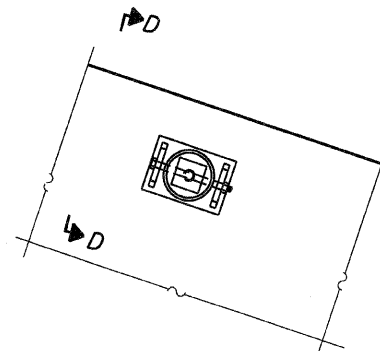

SECTION C-C

(See Detail A for dimensions and details not shown.)

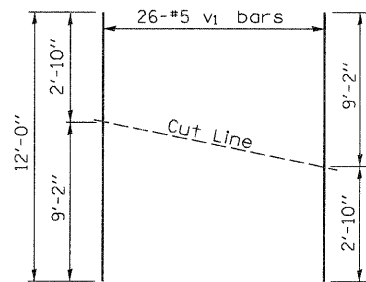

BAR CUTTING DIAGRAM

*Order v1 bars full length. Cut as shown and use remainder of bars in opposite wall.

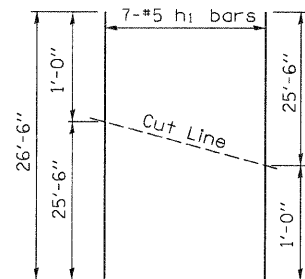

BAR CUTTING DIAGRAM

*Order h1 bars full length. Cut as shown and use remainder of bars in opposite face.

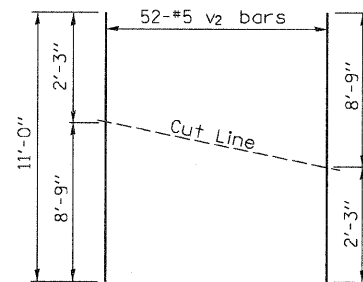

BAR CUTTING DIAGRAM

*Order v2 bars full length. Cut as shown and use remainder of bars in opposite wall.

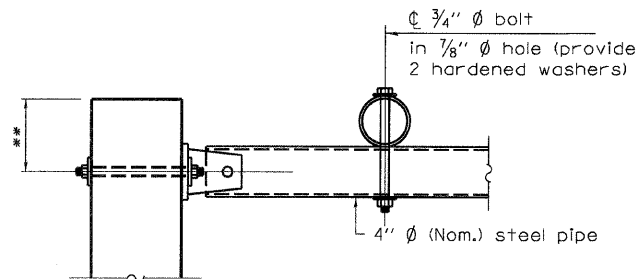

SECTION D-D

** Measured perpendicular to top of culvert wall. In addition, formed hole shall be located a minimum of 6" measured horizontally from any vertical joints necessary for construction of the culvert end section.

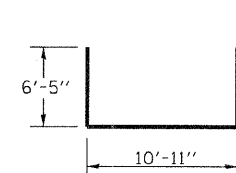

BAR u

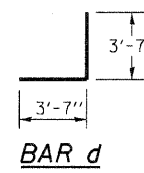

BAR d

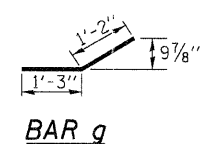

BAR g

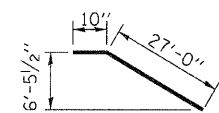

BAR f1

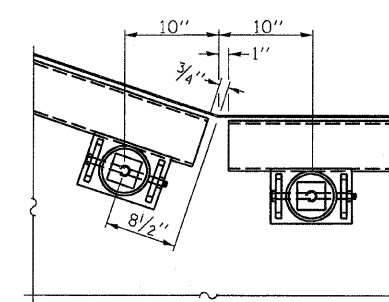

DETAIL B

BILL OF MATERIAL

(For Information Only)

BAR	SIZE	NO.	LENGTH	SHAPE
d	5	140	7'-2"	
f	6	2	10'-11"	
f1	5	4	27'-10"	
g	6	12	2'-5"	
h	5	16	34'-9"	
h1	5	14	26'-6"	
h2	5	24	33'-9"	
h3	5	72	10'-11"	
h4	4	32	2'-10"	
v	5	29	2'-9"	
v1	5	26	12'-0"	
v2	5	52	11'-0"	
u	5	4	23'-9"	
DESCRIPTION		UNIT	QTY.	
CONCRETE STRUCTURES		CU YD	27.9	
REINFORCEMENT BARS		LB	5,040	
DESCRIPTION		UNIT	QTY.	
4" GALVANIZED STEEL PIPE		5e	8'-11"	
		4e	26'-8"	
		4e	6'-8"	
3/4" ϕ GALVANIZED STEEL BOLTS		EACH	20	
*** END ASSEMBLY		EACH	8	
*** SIDE ASSEMBLY		EACH	10	

*** Includes all hardware and steel for Assemblies

DESIGNED	C.T.M.
CHECKED	B.A.N.
DRAWN	C.T.M.
CHECKED	B.A.N.

SHEET NO. 2 2 SHEETS	ROUTE NO.	SECTION	COUNTY	TOTAL SHEETS	SHEET NO.
	FAS 213	(19,20)RS-2	MERCER	231	46
FED. ROAD DIST. NO. 7 ILLINOIS			CONTRACT NO. 64D72 FED. AID PROJECT		