

STATE OF ILLINOIS
DEPARTMENT OF TRANSPORTATION

ROUTE NO.	SECTION	COUNTY	TOTAL SHEETS	SHEET NO.
90/94	*	COOK		295

(1818, ETC, 2324.6-1P) R-9

62300 *(1818, ETC, 2324.6-1P) R-8 62302

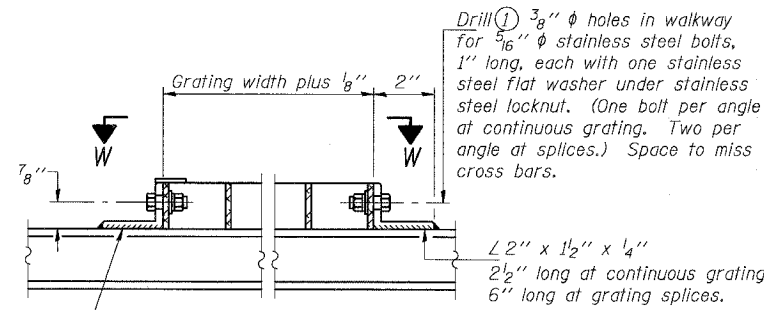
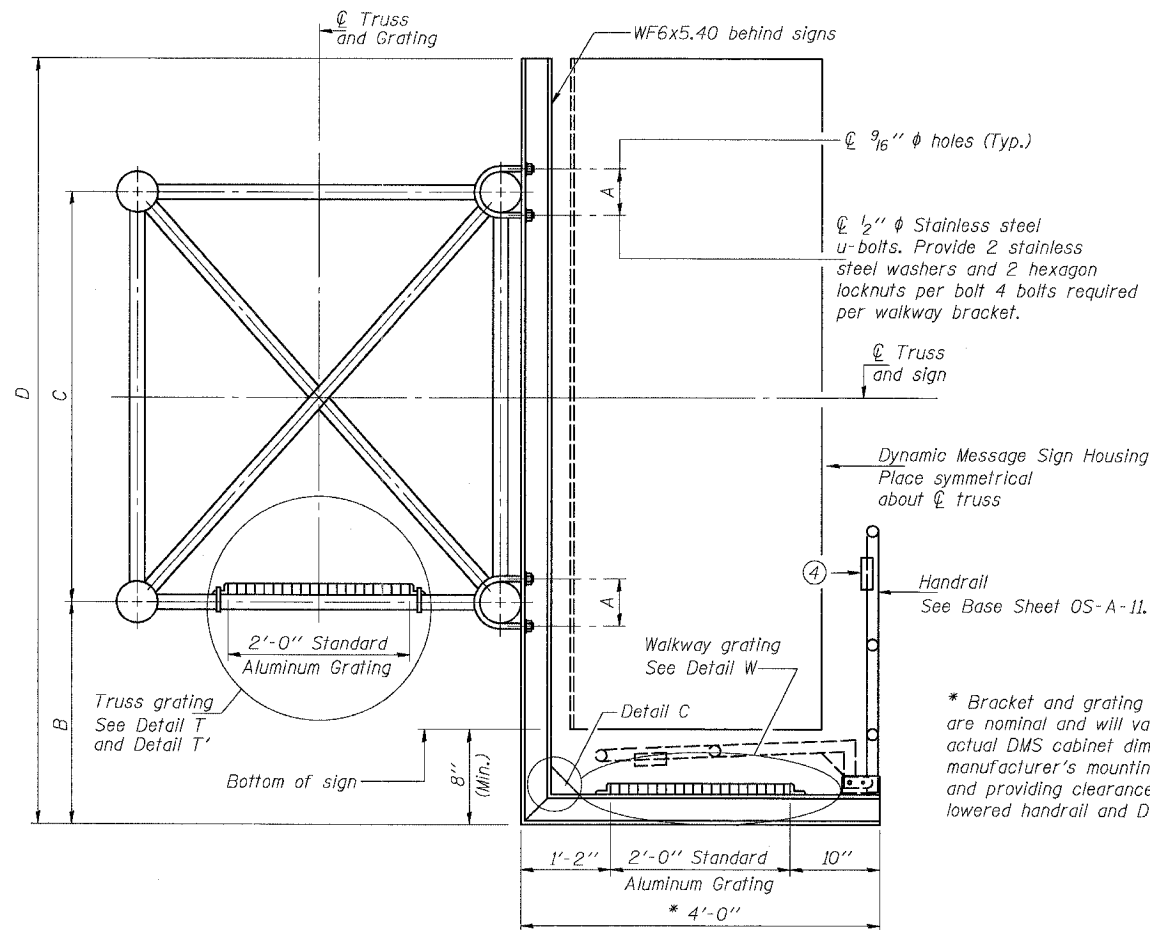

DETAIL W
(Walkway grating)

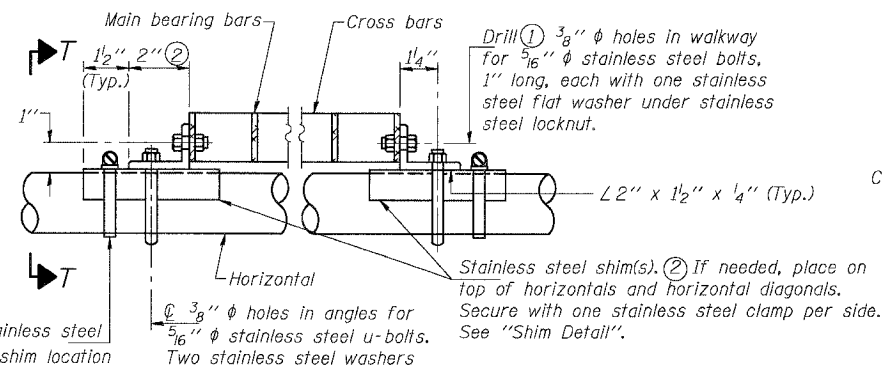

DETAIL T
(Continuous Truss grating)

SPECIFICATIONS FOR STANDARD ALUMINUM GRATING

Main Bearing Bars shall be 3/16" x 1 1/2" on 1 3/16" centers and conform to ASTM B221 Alloy 6061-T6.
Cross bars shall be 3/16" x 1 1/2" on 4" centers and conform to ASTM B221 Alloy 6063-T5 or 6061-T6.

OR

Aluminum Grating with modified "I" sections for main bearing bars shall meet the following requirements:
Main bars shall conform to ASTM B221 Alloy 6061-T6 and have a minimum section modulus equal to 0.0705 in.³ per bar, a depth of 1 1/2", spaced on 1 3/16" centers.
Cross bars shall conform to ASTM B221 Alloy 6063-T5 or T-42 and spaced on 4" centers.

Structure Number	Station	A	B	C	D
ISO161094R057.7	1476+25.00	7 1/2"	1'-5"	7'-0"	9'-2"
ISO161094L055.41	4598+65	7 1/2"	1.25'	7.0'	8.75'

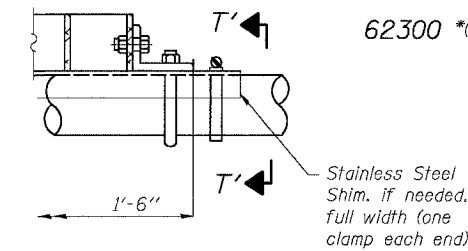

DETAIL T'

(Truss grating splice)
Details not shown same as Detail T.
Alternate materials may be used subject to the Engineer's review and approval.

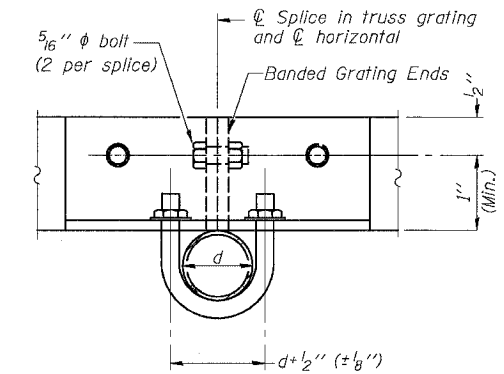

SECTION T'-T'

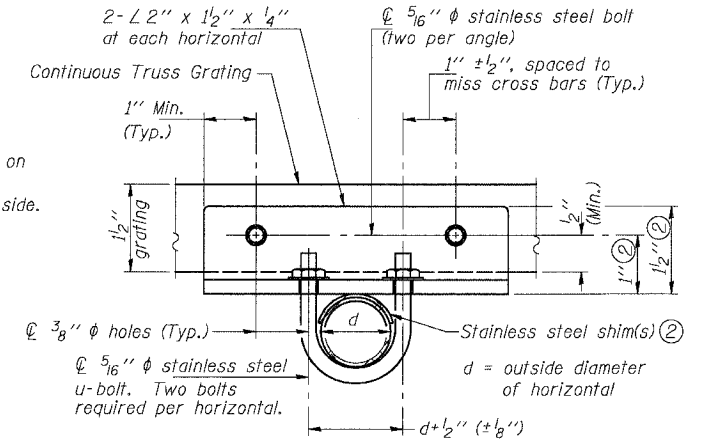

SECTION T-T

- Drilling holes in grating may be done in shop or field, based on Contractor's preference and subject to accurate alignment.
- Stainless steel shims shall be placed as shown in Detail T if needed to compensate for alignment variations between horizontal and diagonal pipes beyond adjustment provided by angles. Thicker shims may be used subject to shims performing properly.
- If Handrail Joint present, weld angle to WF6 and 1/4" extension bars. (See Base Sheet OS-A-11-DMS2.)
- Ø 1/2" x 1/2" x 2" welded to handrail posts to protect locations that contact grating.

SECTION B-B

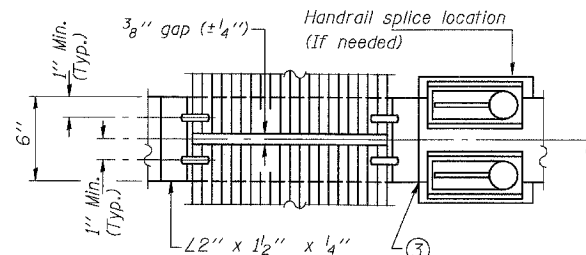
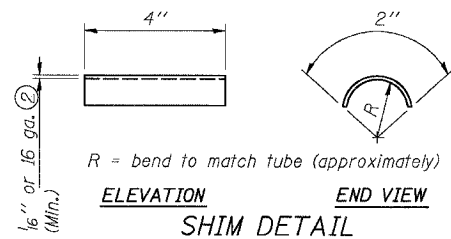

(AT WALKWAY GRATING SPLICE)

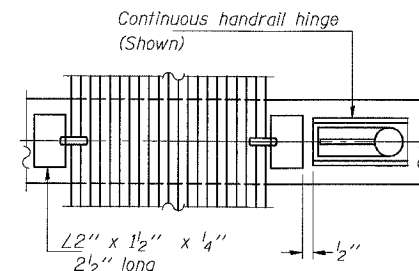

(CONTINUOUS WALKWAY GRATING)

SECTION C-C

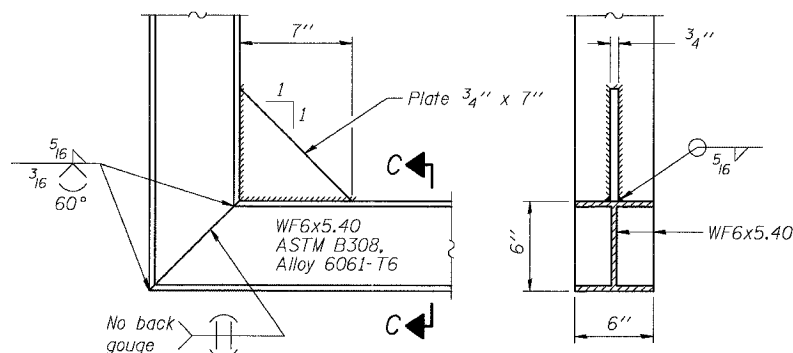

DETAIL C

(See Detail P, Base Sheet OS-A-11-DMS2.)

DESIGNED	19
CHECKED	EXAMINED
DRAWN	PASSED
CHECKED	ENGINEER OF BRIDGES AND STRUCTURES

NUMBER	REVISION	DATE

OS-A-10-DMS2 7/1/2001

OVERHEAD SIGN STRUCTURES
ALTERNATE ALUMINUM WALKWAY DETAILS

F.A.I. 90/94 (DAN RYAN EXPRESSWAY)
31st Street to 71st Street
(SB Express Lanes)
(NB Express Lane Reconstruction)

SGN-17

6/24/2005 11:05:39 AM