

DUNHAM ROAD
EXISTING TYPICAL SECTION
STA. 504+15 TO STA. 509+20.81
STA. 510+81.19 TO STA. 513+10

- EXISTING CONDITIONS:**
- ① HOT-MIX ASPHALT SURFACE COURSE AND BINDER COURSE, 9.75" •
 - ② AGGREGATE SUB-BASE **
 - ③ AGGREGATE SHOULDER **
 - REMOVAL PAID AS PAVEMENT REMOVAL
 - ** REMOVAL PAID AS EARTH EXCAVATION
 - ☒ PAVEMENT REMOVAL
 - ☒ HOT-MIX ASPHALT SURFACE REMOVAL, 2 1/4" (STA. 504+15 TO STA.505+94)

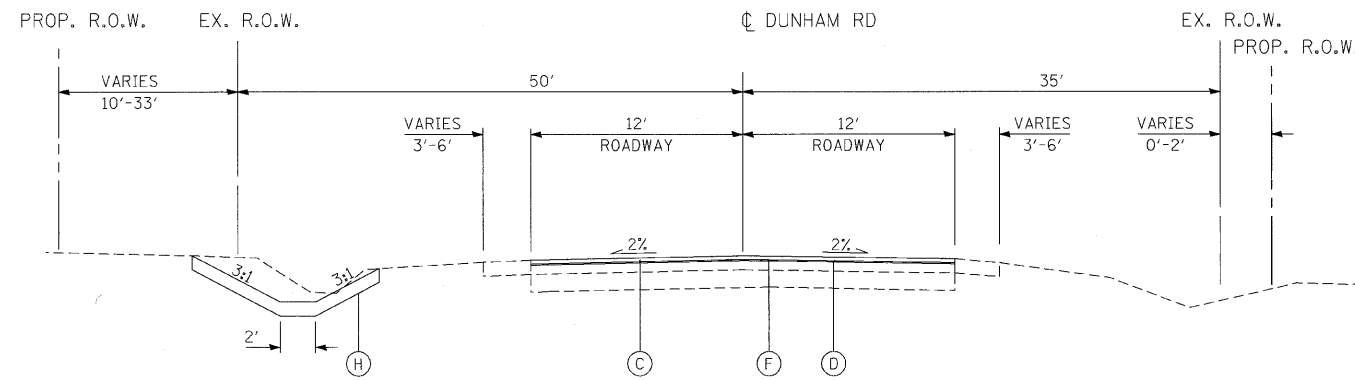

DUNHAM ROAD
PROPOSED TYPICAL SECTION
STA. 504+15 TO STA. 505+94

- PROPOSED IMPROVEMENTS**
- Ⓐ HOT-MIX ASPHALT SURFACE COURSE, MIX "C", N50, 2"
 - Ⓑ HOT-MIX ASPHALT BINDER COURSE, IL-19.0, N50, 4"
 - Ⓒ HOT-MIX ASPHALT SURFACE COURSE, MIX "C", N50, 1 1/2"
 - Ⓓ LEVELING BINDER (MACHINE METHOD), N50, 3/4"
 - Ⓔ HOT-MIX ASPHALT SHOULDER, 6"
 - Ⓕ BITUMINOUS MATERIALS (PRIME COAT)
 - Ⓖ AGGREGATE SUBGRADE 12"
 - Ⓗ TOPSOIL, FURNISH AND PLACE 6" AND SEEDING PER LANDSCAPING PLAN
 - Ⓘ COMBINATION CONCRETE CURB AND GUTTER TYPE B-6.24
 - ⓵ STEEL PLATE BEAM GUARD RAIL, TYPE A

HOT-MIX ASPHALT MIXTURE REQUIREMENTS

OPERATION	MIXTURE TYPE	AIR VOIDS @ Ndes
ROADWAY RECONSTRUCTION	HOT-MIX ASPHALT SURFACE COURSE, MIX "C", N50 (IL-9.5mm), 2"	4% @ 50 GYR.
	HOT-MIX ASPHALT BINDER COURSE, IL-19.0, N50, 4"	4% @ 50 GYR.
ROADWAY RESURFACING	HOT-MIX ASPHALT SURFACE COURSE, MIX "C", N50 (IL-9.5mm), 1 1/2"	4% @ 50 GYR.
	LEVELING BINDER (MACHINE METHOD), N50, 3/4"	4% @ 50 GYR.
SHOULDER RECON	HOT-MIX ASPHALT SHOULDERS (HMA BINDER IL-19.0mm), 6"	2% @ 30 GYR.
BRIDGE APPROACH PAVEMENT CONNECTOR (FLEXIBLE)	HOT-MIX ASPHALT SURFACE COURSE, MIX "C", N50 (IL-9.5mm), 2"	4% @ 50 GYR.
	HOT-MIX ASPHALT BINDER COURSE, IL 19.0, N50, 4"	4% @ 50 GYR.
STABILIZED DRIVEWAY	HOT-MIX ASPHALT SURFACE COURSE, MIX "C", N50 (IL-9.5mm), 2"	4% @ 50 GYR.
	HOT-MIX ASPHALT BASE COURSE, (HMA BINDER IL-19.0mm), 6" - PE	4% @ 50 GYR.

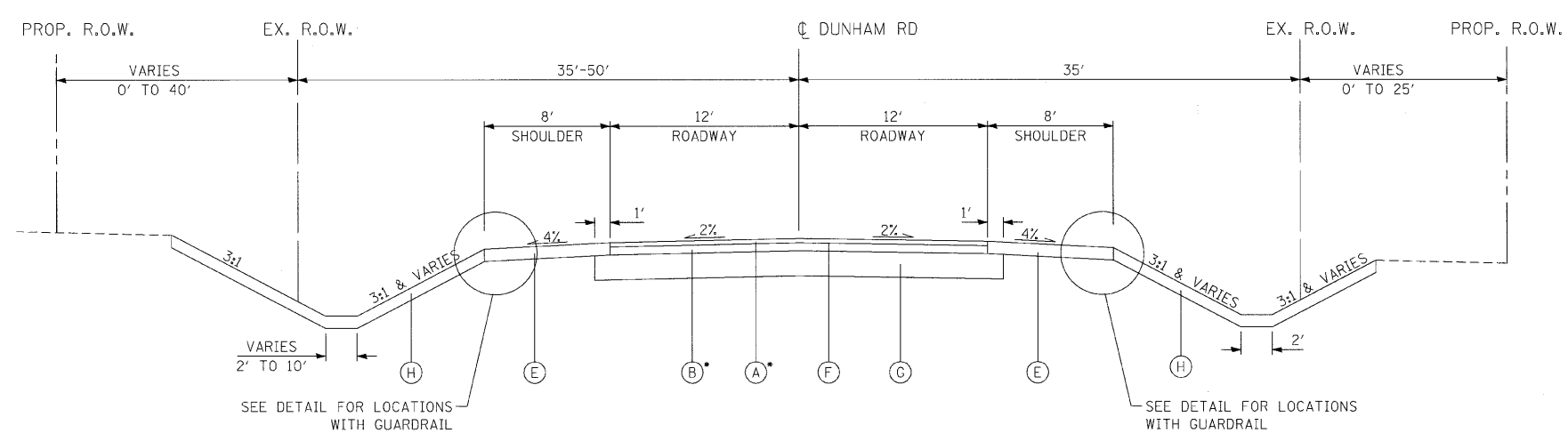

DUNHAM ROAD
PROPOSED TYPICAL SECTION
STA. 505+94 TO STA. 509+20.81
STA. 510+81.19 TO STA. 513+10

• BRIDGE APPROACH PAVEMENT CONNECTOR (FLEXIBLE) STA. 508+25 TO STA.509+25 AND STA. 510+77 TO STA. 511+77 (SEE IDOT STANDARD DETAIL 420401-08)

- THE UNIT WEIGHT USED TO CALCULATE ALL HMA SURFACE MIXTURE QUANTITIES IS 112 LB/SQ IN/YD
- THE "AC TYPE" FOR POLYMERIZED HMA MIXES SHALL BE "SBS/SBR PG 70 -22 AND FOR NON-POLYMERIZED HMA SHALL BE "PG 64 -22" UNLESS MODIFIED BY DISTRICT ONE SPECIAL PROVISIONS. FOR "PERCENT OF RAP" SEE DISTRICT ONE SPECIAL PROVISIONS.

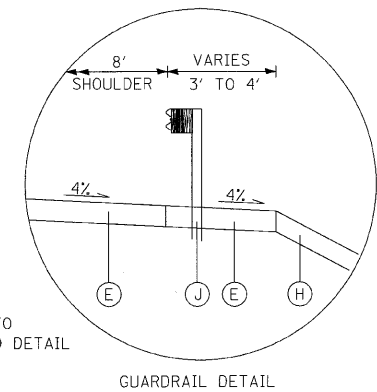

GUARDRAIL DETAIL

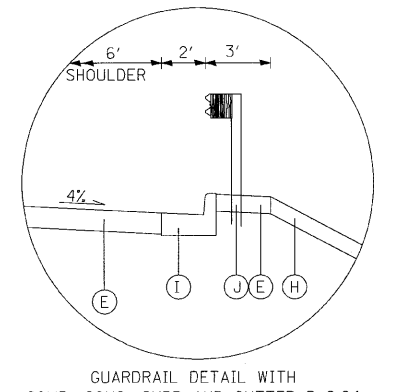

GUARDRAIL DETAIL WITH COMB. CONC. CURB AND GUTTER B-6.24

FILE NAME: m:\proj\3381\3381.dwg USER: jph DATE: 8/2/2010 TIME: 10:05:10 AM

Ciorba Group, Inc.
CONSULTING ENGINEERS
5607 North Cumberland Avenue, Suite 402
Chicago, Illinois 60656
Tel. 773.775.4009 Fax 773.775.4014

USER NAME = ospina	DESIGNED - CLG	REVISED - 8/02/2010
	DRAWN - EPS	REVISED -
PLOT SCALE = 1:8000 1/4" IN.	CHECKED - MJL	REVISED -
PLOT DATE = 8/2/2010	DATE - 6/18/2010	REVISED -

MCHENRY COUNTY DIVISION OF TRANSPORTATION

TYPICAL SECTIONS

SCALE: N.T.S.	SHEET NO.	OF	SHEETS	STA.	TO STA.
---------------	-----------	----	--------	------	---------

F.A.S. RTE. 1233	SECTION 06-00321-00-BR	COUNTY MCHENRY	TOTAL SHEETS 48	SHEET NO. 6
CONTRACT NO. 63516			FED. ROAD DIST. NO. 1 (ILLINOIS) FED. AID PROJECT	