

F.A.P. RTE.	SECTION	COUNTY	TOTAL SHEETS	SHEET NO.
704	(1)N & TS-1	McLEAN	497	314
STA. N/A		TO STA. N/A		
FED. ROAD DIST. NO.		ILLINOIS FED. AID PROJECT		
CONTRACT NO. 70514				

# SLOTTED DRAIN PIPE

LOADING CONDITION	MAX. EXTENDER HEIGHT - "H"
H20/H25 • 750 PSI CONCRETE	19"
• 125 PSI TIRE PRESSURE	

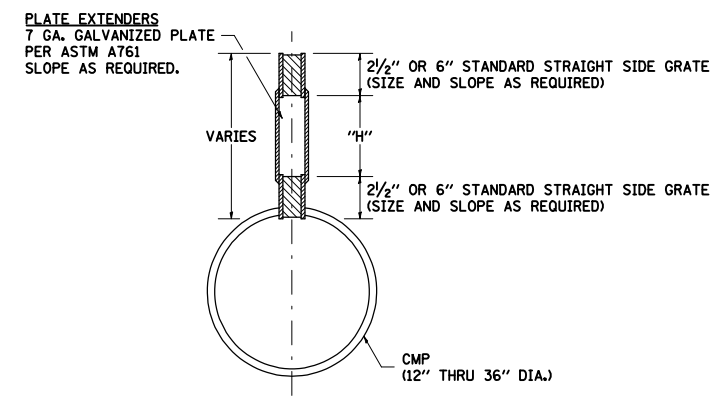
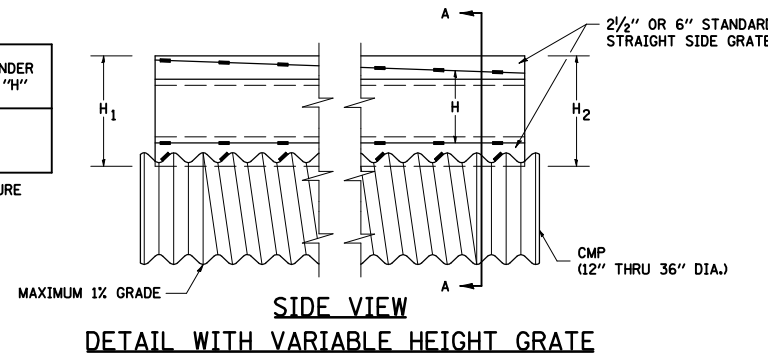

**GENERAL**

Class SI Concrete shall be used throughout. This specification covers Slotted Drain used for the removal of water as shown on the plans. The Slotted Drain shall be Corrugated Pipe Culvert with Integral Slotted Drains. Before placing the concrete adjacent to the pipe, the slot shall be covered by either thin, flat metal sheeting or by a board notched to fit over the grate bars. This covering must fit closely in the slot to prevent entry of concrete into the pipe. Paving over the slotted drain will then be one continuous operation over the protected drain. The protection for the drain slot shall then be removed. The pipe shall drain into the side of the Inlet. The opening where the slot is removed shall be covered to prevent concrete from entering the pipe. The Corrugated Steel Pipe used in the Slotted Drain shall meet the requirements of AASHTO M36/ASTM A760. The CMP shall be ALUMINIZED STEEL Type 2. The diameter shall be as shown on the plans. Steel grating shall meet the galvanizing requirements of AASHTO M11. This work will be paid for at the contract unit price per foot for SLOTTED DRAIN of the pipe diameter specified WITH VARIABLE SLOT, or SLOTTED DRAIN, of the pipe diameter specified, WITH 6" SLOT, and shall include concrete and grating for depth specified on plans. Use approved end cap to prevent concrete entry into the pipe during gutter construction on the upstream end of the pipe.

**CONNECTIONS**

The Corrugated Steel Pipe shall have a minimum of two rerolled annular ends. The Slotted Drain bands shall be modified HUGGER Bands to secure the pipe and prevent infiltration of the backfill. When the Slotted Drain is banded together, the adjacent grates shall have a maximum 3" gap.

**GRATES**

The grates shall be manufactured from ASTM A670, Grade 36 steel. The spacers and bearing bars (sides) shall be 3/16" material ±0.008". The spacers shall be on 6" centers and welded on both sides to each bearing bar (sides) with four (4) 1-1/4" long 3/16" fillet welds on each side of the bearing bar. The plate extender shall be 7 gage steel meeting ASTM A761. The engineer may call for tensile strength tests on the grate if the grate is not in compliance with the above spacer specifications. If tensile strength tests are called for, minimum results for an in-place spacer pulled perpendicular to the bearing bar shall be:  
T = 12,000 pounds for 2-1/2" grate  
T = 15,000 pounds for 6" grate

**GALVANIZING**

The grate and plate extenders shall be galvanized in accordance with ASTM A123 except with a 2 oz. galvanized coating.

**GRATE ATTACHED TO CSP**

The grate shall be fillet welded with a minimum weld 1" long to the CSP on each side of the grate at every other corrugation.

**TOLERANCES - FINISHED SLOTTED DRAIN - 20' LENGTHS**

Vertical Bow = ± 3/8"  
Horizontal Bow = ± 5/8"  
Twist = ± 1/2"

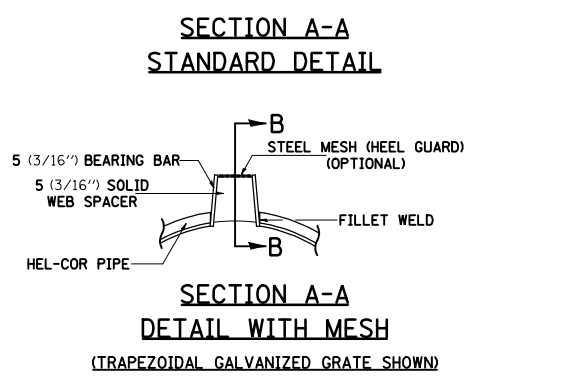
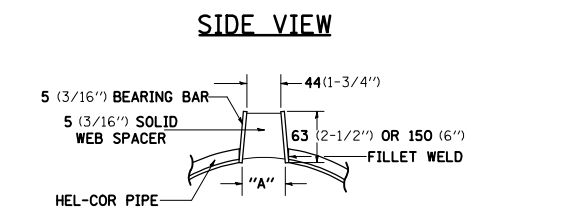
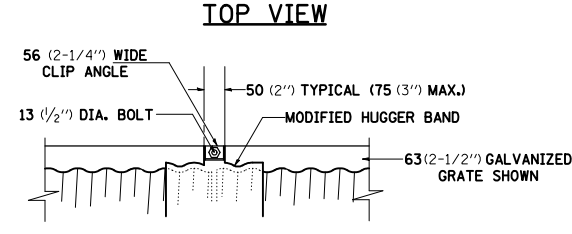
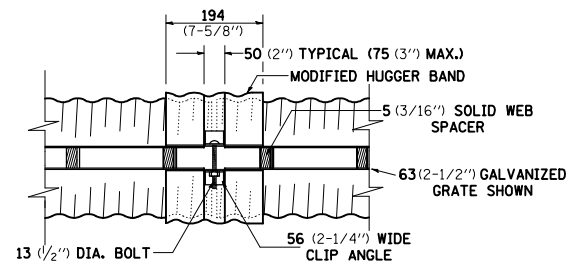

STANDARD SIZES						
GAGE OF PIPE	DIAMETER OF PIPE					
	300 (12")	375 (15")	450 (18")	600 (24")	750 (30")	900 (36")
16	X	X	X	X	X	X
14	X	X	X	X	X	X
12	N.A.	N.A.	N.A.	N.A.	X	X

GRATE TYPE	"A"
VERT 63(2-1/2")	44(1-3/4")
VERT 150 (6")	44(1-3/4")
TRAP 63(2-1/2")	56(2-1/4")
TRAP 150 (6")	75 (3")

VERT = VERTICAL  
TRAP = TRAPEZOIDAL

**SLOTTED DRAIN NOTES**

- GRATING IS AVAILABLE IN DEPTHS OF 63 (2-1/2") AND 150 (6").
- VERTICAL GRATING (STRAIGHT SIDES) WITH VERTICAL SPACERS IS ALSO AVAILABLE.
- FOR 150 (6") VERTICAL & TRAPEZOIDAL REQUIREMENTS, THE SLOTTED DRAIN BAND MAY BE FURNISHED WITH THE 100 (4") TECHCO BAND ANGLE.
- DIMENSIONS ARE SUBJECT TO MANUFACTURING TOLERANCES.
- DIMENSIONS FOR H<sub>1</sub> AND H<sub>2</sub> AS REQUIRED.
- H<sub>1</sub> AND H<sub>2</sub> MEASURED FROM TOP OF GRATE TO BOTTOM OF GRATE.

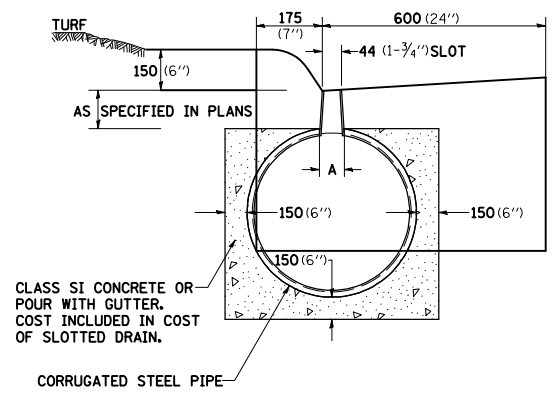
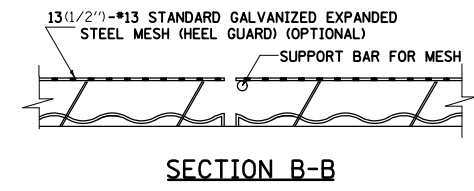
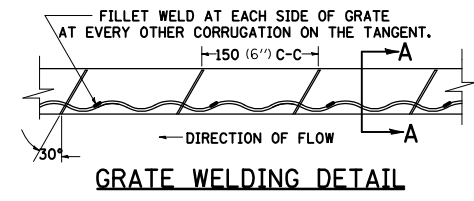
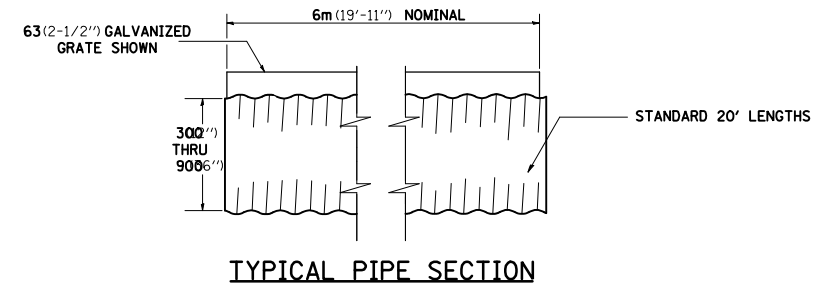
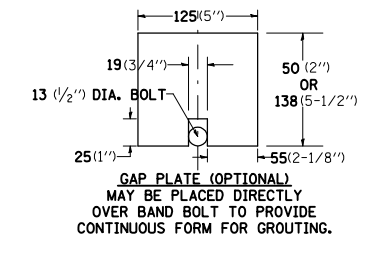
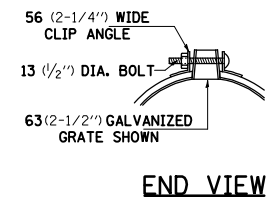

**DETAIL FOR CURB & GUTTER**

ALL DIMENSIONS ARE IN MILLIMETERS (INCHES) UNLESS OTHERWISE NOTED.

REVISIONS		ILLINOIS DEPARTMENT OF TRANSPORTATION
NAME	DATE	
		SPECIAL DETAILS

DATE 05-27-09