

STATE OF ILLINOIS
DEPARTMENT OF TRANSPORTATION

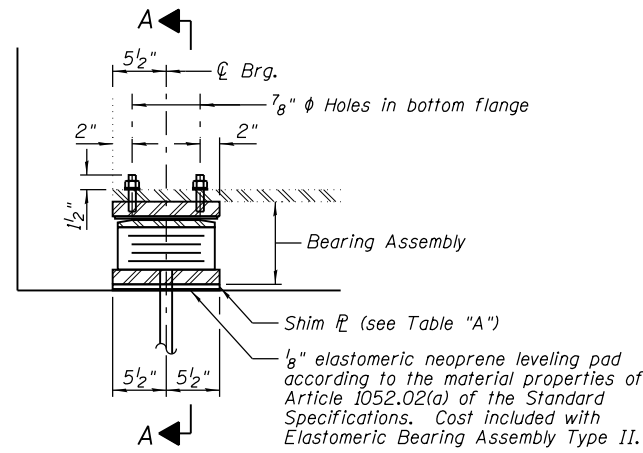

ELEVATION AT WEST ABUT.

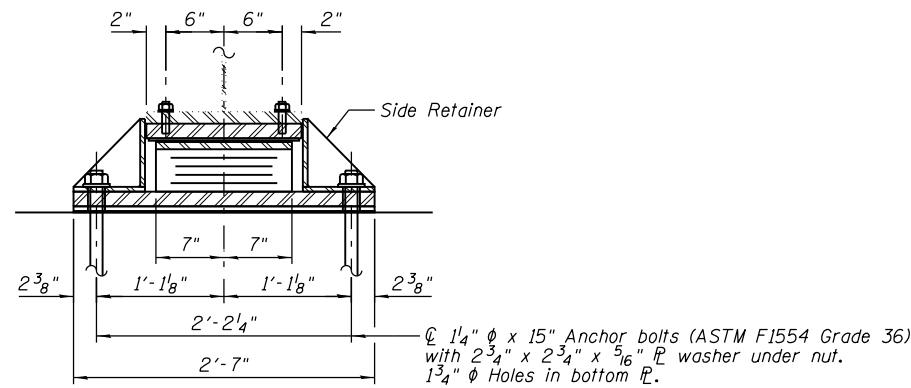

SECTION A-A

TYPE II ELASTOMERIC EXP. BRG.

(At West Abutment - 6 Required)

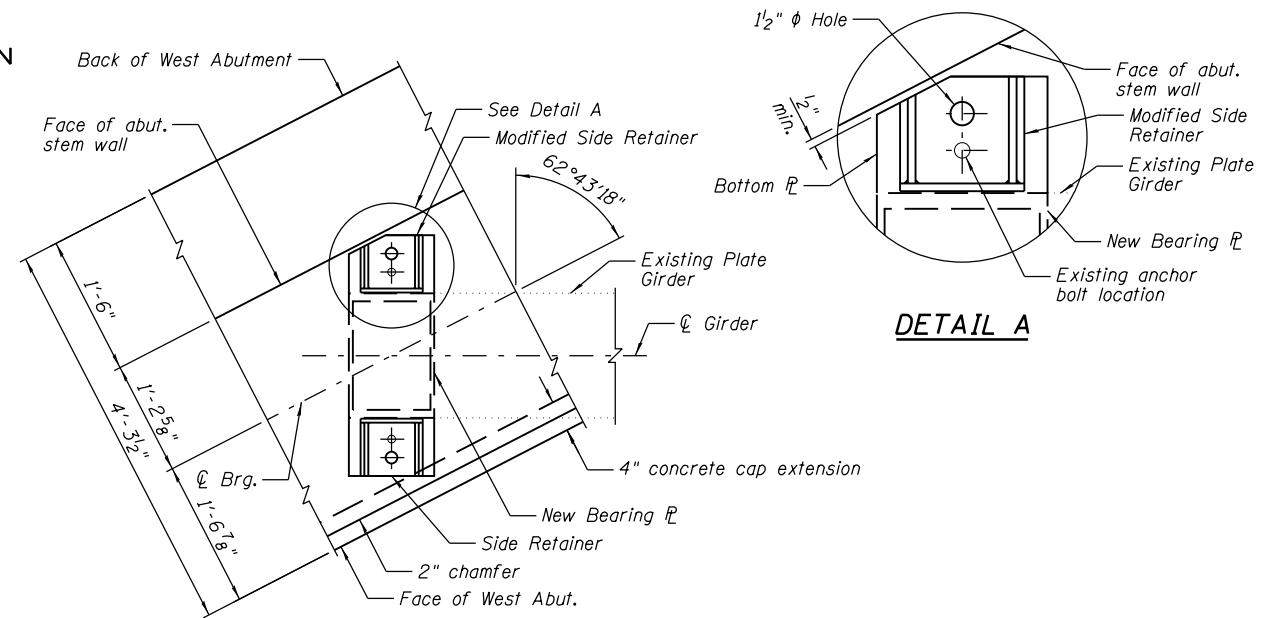

BEARING PLAN AT WEST ABUTMENT

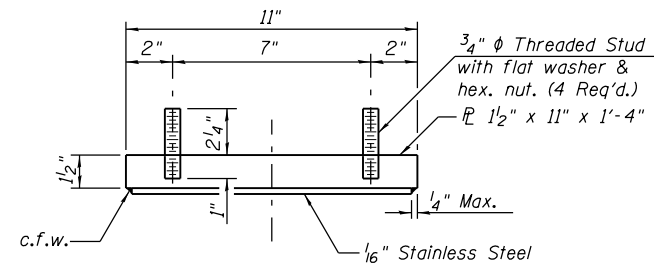

TOP BEARING ASSEMBLY

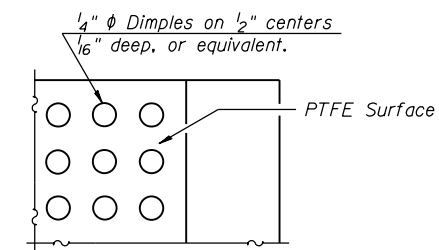

PLAN-PTFE SURFACE

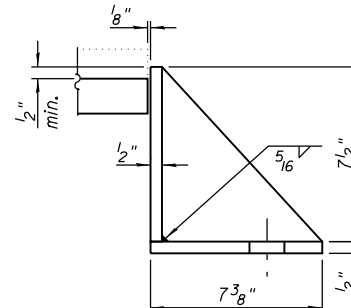

SIDE RETAINER

Equivalent rolled angle with stiffeners will be allowed in lieu of welded plates.

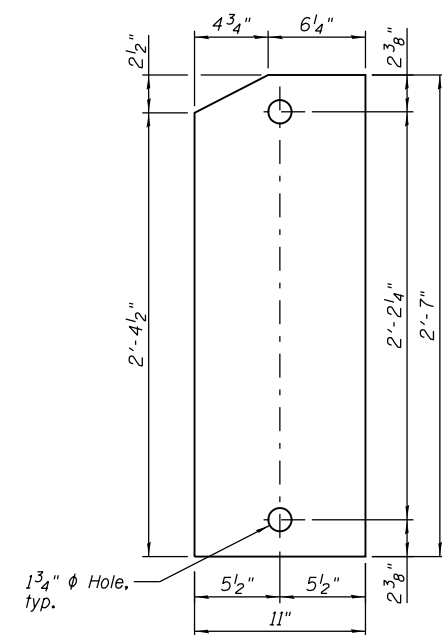

BOTTOM PLATE PLAN

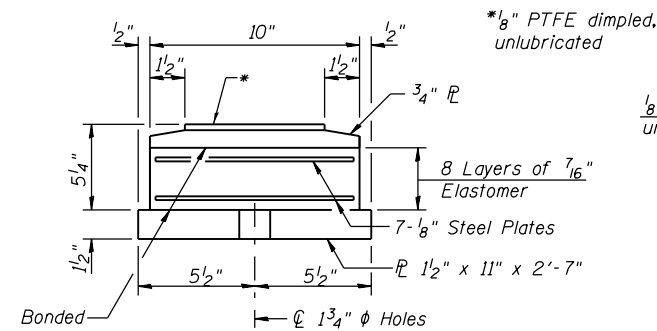

BOTTOM BEARING ASSEMBLY

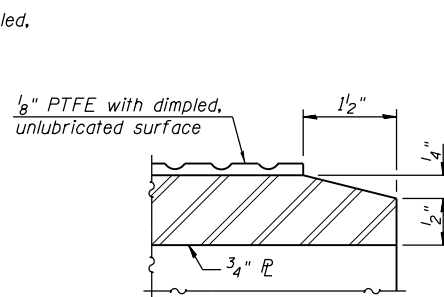

SECTION THRU PTFE

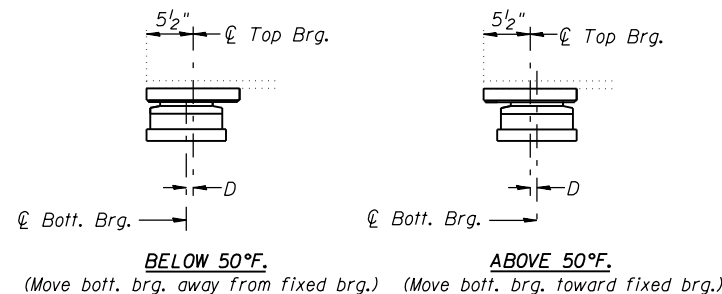

SETTING ANCHOR BOLTS AT EXP. BRG.

$D = \frac{1}{8}$ per each 100' of expansion for every 15° temp. change from the normal temp. of 50°F.

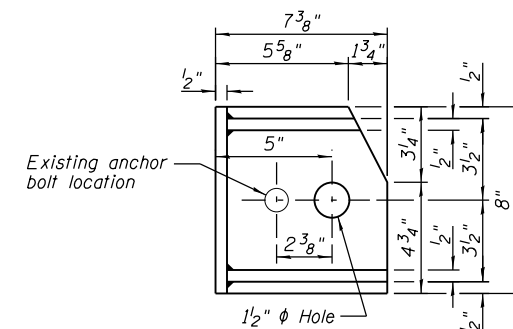

MODIFIED SIDE RETAINER

Equivalent rolled angle with stiffeners will be allowed in lieu of welded plates.

Notes:
Anchor bolts shall be ASTM F1554 all-thread (or an Engineer-approved alternate material) of the grade(s) and diameter(s) specified. ASTM A307 Grade C anchor bolts may be used in lieu of ASTM F1554 Grade 36 (Fy=36ksi). The corresponding specified grade of AASHTO M314 anchor bolts may be used in lieu of ASTM F1554.
Anchor bolts for Type II bearings shall be placed in holes drilled in the concrete through holes in the bottom bearing plate after members are in place. Side retainers shall be placed after bolts are installed.
Drilled and set anchor bolts shall be installed according to Article 521.06 of the Standard Specifications.
Side retainers and other steel members required for the bearing assembly shall be included in the cost of Elastomeric Bearing Assembly, Type II.
The 1/8" PTFE sheet shall be bonded directly to the top steel plate with a two-component, medium viscosity epoxy resin, conforming to the requirements of the Federal Specification MMM-A-134, Type I. The bond agent shall be applied on the full area of the contact surfaces.
Bonding of 1/8" PTFE sheet during vulcanizing process will be permitted provided the process and method of adjusting assembly height is approved by the Engineer.

BILL OF MATERIAL

Item	Unit	Total
Elastomeric Bearing Assembly, Type II	Each	6
Anchor Bolts, 1 1/4"	Each	12

TABLE "A"

Girder No.	Shim Thickness
4	1/8"
5	5/8"

NOTE:

Two 1/8 in. adjusting shims shall be provided for each bearing in addition to all other plates or shims and placed as shown on bearing details.

TYPE II ELASTOMERIC BEARING DETAILS STRUCTURE NO. 084-0078

DESIGNED JML
CHECKED MSW
DRAWN DJM
CHECKED MGO/MSW

DATE 08/09/10

SHEET NO. B26	F.A.I. RTE.	SECTION	COUNTY	TOTAL SHEETS	SHEET NO.
	72	(84-3HB-5)BR	SANGAMON	84	62
42 SHEETS	SN 084-0078		CONTRACT NO. 72C70		
FED. ROAD DIST. NO. 6		ILLINOIS FED. AID PROJECT			