

|          |          |         |       |          |           |
|----------|----------|---------|-------|----------|-----------|
| DATE     | DESIGNED | CHECKED | DRAWN | PROJECT  | SHEET NO. |
| 164-3-BY | Greene   | 55      | 6     | 6 SHEETS |           |

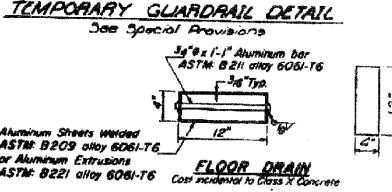
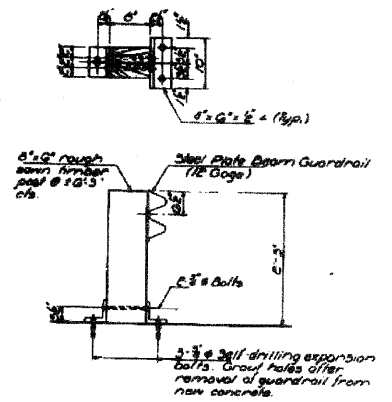

**BILL OF MATERIAL**

| Bar | No  | Size | Length | Shape |
|-----|-----|------|--------|-------|
| a   | 540 | #6   | 17'-3" |       |
| b   | 345 | #5   | 21'-6" |       |
| bi  | 10  | #6   | 21'-6" |       |
| bc  | 60  | #6   | 12'-0" |       |
| d   | 204 | #4   | 2'-10" |       |

|                          |        |       |
|--------------------------|--------|-------|
| Reinforcement Bars       | Lbs    | 23520 |
| Class. Concrete          | Cu Yds | 765   |
| Structural Steel         | Lbs    | 18000 |
| Temp. Guardrail          | Lbs    | 102   |
| Adjust. Structural Steel | Lbs    | 1000  |

1 See Special Provisions.

**SUPERSTRUCTURE**  
 F.A.R.T.E. 164 (U.S. 67) SEC. 3 BY  
 GREENE COUNTY  
 STA. 222+94.00

**FOR INFORMATION ONLY**

|                      |                    |            |           |   |                              |                           |                         |        |              |           |  |
|----------------------|--------------------|------------|-----------|---|------------------------------|---------------------------|-------------------------|--------|--------------|-----------|--|
| FILE NAME =          | USER NAME = #USER# | DESIGNED - | REVISED - | <b>STATE OF ILLINOIS<br/>DEPARTMENT OF TRANSPORTATION</b> | <b>EXISTING BRIDGE PLANS</b> | F.A.P. RTE.               | SECTION                 | COUNTY | TOTAL SHEETS | SHEET NO. |  |
| #FILE#               |                    | DRAWN -    | REVISED - |   |                              | 10                        | 3B-1                    | GREENE | 59           | 47        |  |
| PLOT SCALE = #SCALE# |                    | CHECKED -  | REVISED - |   |                              | CONTRACT NO. 76C15        |                         |        |              |           |  |
| PLOT DATE = #DATE#   |                    | DATE -     | REVISED - |   |                              | ILLINOIS FED. AID PROJECT |                         |        |              |           |  |
|                      |                    |            |           |   |                              | SCALE: NONE               | SHEET NO. 2 OF 4 SHEETS | STA.   | TO STA.      |           |  |