

STATE OF ILLINOIS
DEPARTMENT OF TRANSPORTATION

GENERAL NOTES

1. Reinforcement bars shall conform to the requirements of ASTM A706 Gr 60. See Special Provisions.
2. Reinforcement bars designated (E) shall be epoxy coated.
3. Plan dimensions and details relative to existing plans are subject to nominal construction variations. The Contractor shall field verify existing dimensions and details affecting new construction and make necessary approved adjustments prior to construction or ordering of materials. Such variations shall not be cause for additional compensation for a change in scope of the work, however, the Contractor will be paid for the quantity actually furnished at the unit price bid for the work.
4. The existing structural steel coating contains lead. The Contractor shall take appropriate precautions to deal with the presence of lead on this project.
5. Layout of the slope protection system may be varied to suit ground conditions in the field as directed by the Engineer.
6. Excavation shown behind existing abutment walls shall be performed before setting the new PPC deck beams.
7. No in-stream work will be allowed on this project.
8. The Contractor is advised that the existing PPC deck beams are in a deteriorated condition with reduced load carrying capacity. It is the Contractor's responsibility to account for the condition of the beams when developing construction procedures for removal and replacement of the superstructure.
9. Any damage done to the bridge during beam removal shall be repaired by the Contractor. Cost included with Removal of Existing Superstructures No. 1.
10. If the Contractor's procedures for existing beam removal or placement of new beams involves placement of heavy equipment on the new or existing deck beams, a detailed procedure shall be submitted to the Engineer for approval. The procedure shall include calculations, sealed by an Illinois Licensed Structural Engineer, verifying the structural adequacy of the beams for the proposed loads. Cost included with Precast Prestressed Concrete Deck Beams (27" Depth).
11. No drilling will be permitted into the new PPC deck beams.
12. The minimum thickness of the Concrete Wearing Surface shall be 5" and shall vary as required to adjust for the new profile grade and beam camber.
13. Concrete Removal and substructure repairs required for the stage being constructed shall be completed prior to placement of the new PPC deck beams.
14. The existing bearing pads at the expansion ends of the deck beams contain asbestos. See Special Provisions.
15. Out to out widths shown for deck and approach slabs are the minimum widths required. Variations in the new deck beams and erection tolerances may result in additional width. The Contractor will be paid for the quantity actually furnished based upon the unit price bid for the work.

STRUCTURE INDEX OF SHEETS

General Plan	Sheet No. 1 of 20
General Data	Sheet No. 2 of 20
Stage Construction Details	Sheet No. 3 of 20
Top of North Approach Slab Elevations	Sheet No. 4 of 20
Top of South Approach Slab Elevations	Sheet No. 5 of 20
Superstructure	Sheet No. 6 of 20
Superstructure Details	Sheet No. 7 of 20
Bridge Approach Slab Details	Sheet No. 8-9 of 20
Steel Railing, Type SM with Concrete Wearing Surface	Sheet No. 10 of 20
27"x48" PPC Deck Beam	Sheet No. 11 of 20
27"x48" PPC Deck Beam Details	Sheet No. 12 of 20
Abutment Concrete Removal	Sheet No. 13 of 20
North Abutment Repairs and Modifications	Sheet No. 14 of 20
South Abutment Repairs and Modifications	Sheet No. 15 of 20
Pier Repairs	Sheet No. 16 of 20
Pier Details	Sheet No. 17 of 20
Bar Splicer Assembly and Mechanical Splicer Details	Sheet No. 18 of 20
Temporary Concrete Barrier for Stage Construction	Sheet No. 19 of 20
Soil Boring Log	Sheet No. 20 of 20

TOTAL BILL OF MATERIAL

ITEM	UNIT	SUPER	SUB	TOTAL
Porous Granular Embankment, Special	Cu. Yd.		40	40
Stone Dumped Riprap, Class A3	Sq. Yd.		60	60
Removal of Existing Superstructures No. 1	Each	1		1
Concrete Removal	Cu. Yd.		6.6	6.6
Structure Excavation	Cu. Yd.		55	55
Concrete Structures	Cu. Yd.		31.0	31.0
Concrete Superstructure	Cu. Yd.	95.0		95.0
Bridge Deck Grooving	Sq. Yd.	638		638
Protective Coat	Sq. Yd.	638		638
Precast Prestressed Concrete Deck Beams (27" Depth)	Sq. Ft.	3,818		3,818
Reinforcement Bars, Epoxy Coated	Pound	28,810	4,890	33,700
Bar Splicers	Each	262	90	352
Steel Railing, Type SM	Foot	332		332
Temporary Sheet Piling	Sq. Ft.		300	300
Name Plates	Each	1		1
Epoxy Crack Injection	Foot		68	68
Geocomposite Wall Drain	Sq. Yd.		27	27
Pipe Underdrains for Structures 4"	Foot		100	100
Removal of Existing Precast Concrete Units	Sq. Ft.	300		300
Structural Repair of Concrete (Depth Equal to or Less Than 5")	Sq. Ft.		46	46
Concrete Wearing Surface, 5"	Sq. Yd.	425		425
Asbestos Bearing Pad Removal	Each	40		40

GENERAL DATA

STRUCTURE NO. 077-0016

SHEET NO. 2	F.A.S. RTE. 2936	SECTION 14BR-1	COUNTY PIKE	TOTAL SHEETS 68	SHEET NO. 17
20 SHEETS	CONTRACT NO. 78071				
FED. ROAD DIST. NO. ILLINOIS FED. AID PROJ.					

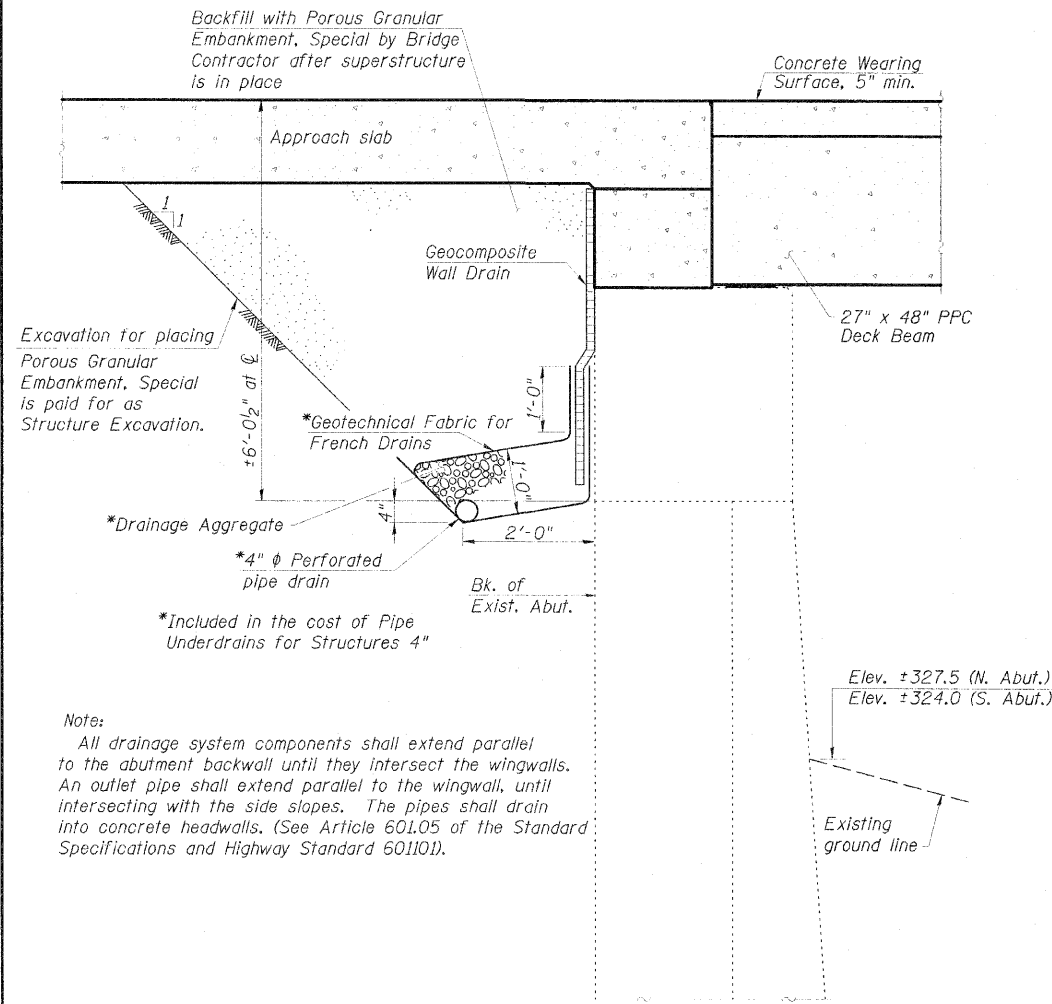

SECTION THRU ABUTMENT
(Dimensions are at Rt. L's)

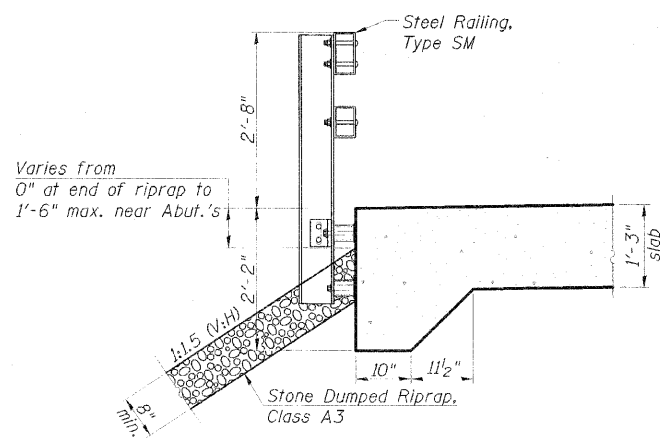

SECTION A-A

ESCA CONSULTANTS, INC.		
DESIGNED BY:	MTD	01/10
DRAWN BY:	DWH	01/10
CHECKED BY:	MTD	01/10
APPROVED BY:	RDP	05/10