

FABRIC BEARING PAD
(Interior)
(12 Required)

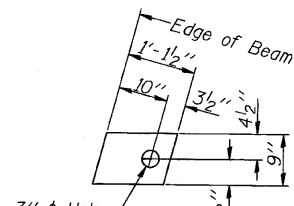

FABRIC BEARING PAD
(Exterior)
(8 Required)

FIXED

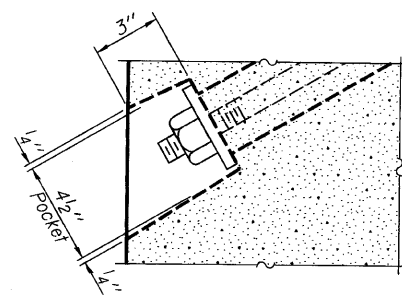

SECTION A-A

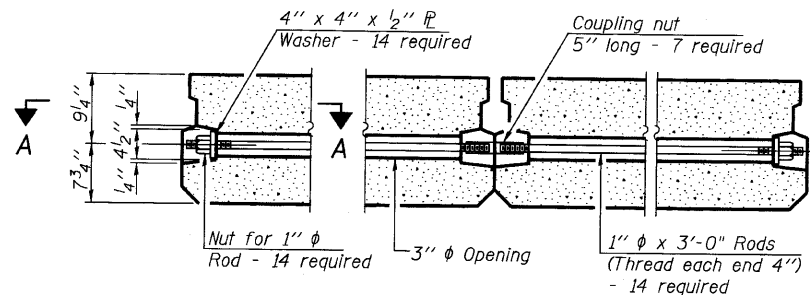

TYPICAL TRANSVERSE TIE ASSEMBLY

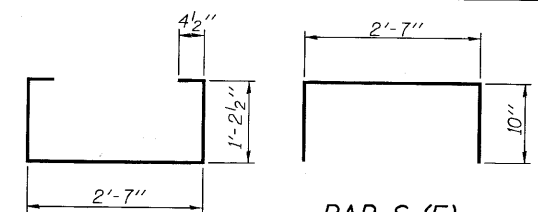

BAR S(E)

BAR S1(E)

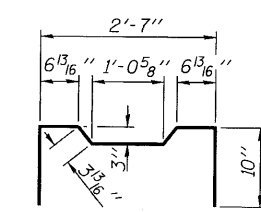

BAR S2(E)

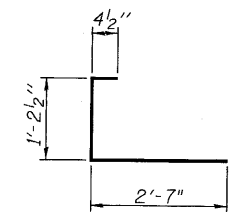

BAR S3(E)

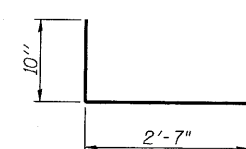

BAR S4(E)

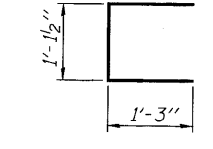

BAR U(E)

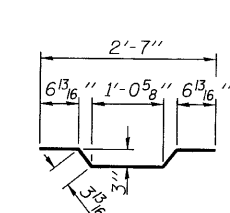

BAR A1(E)

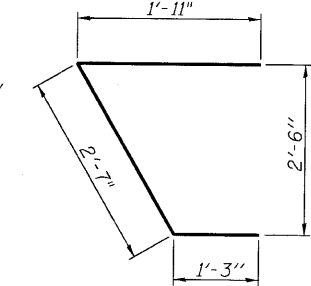

BAR U1(E)

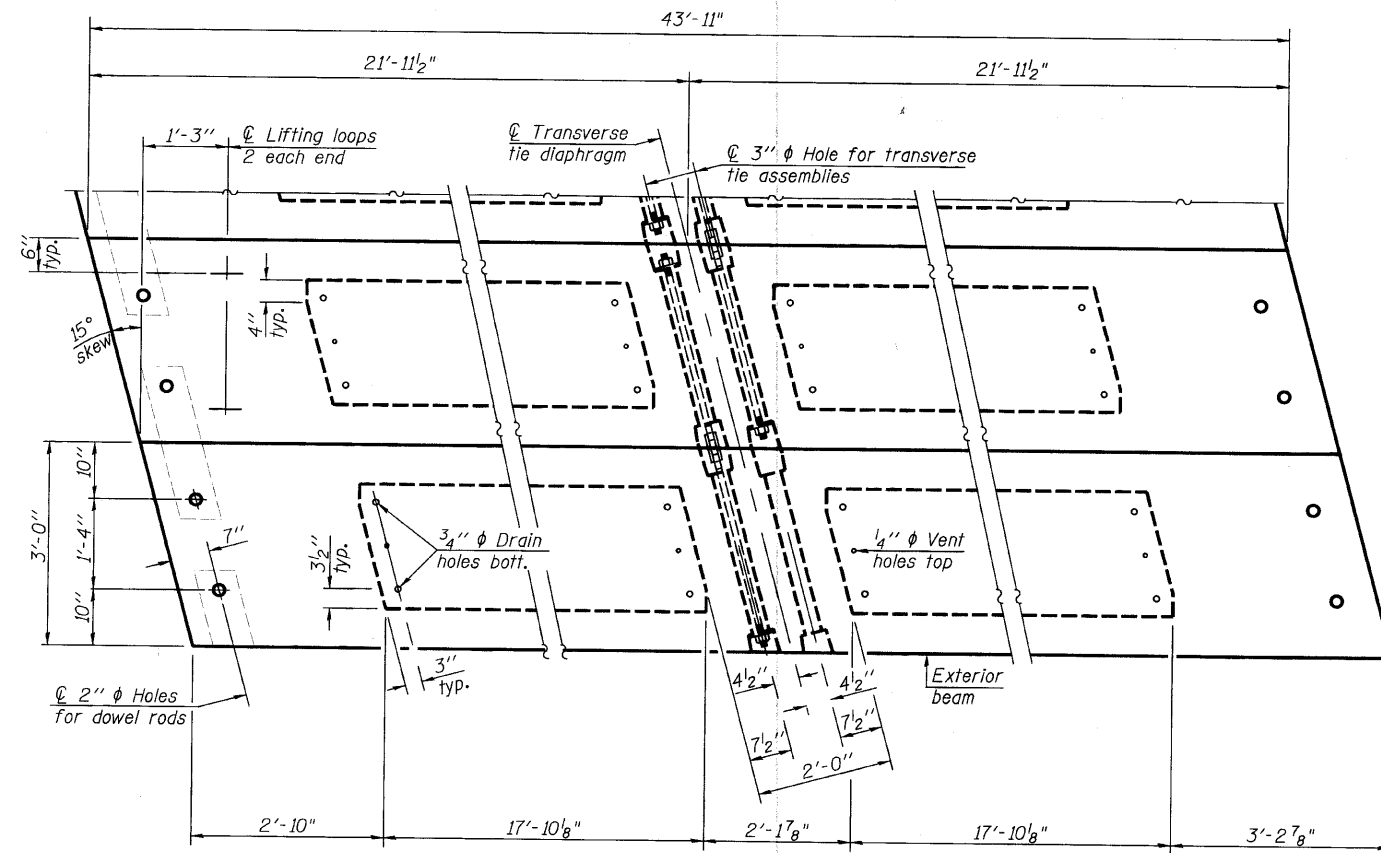

PLAN VIEW

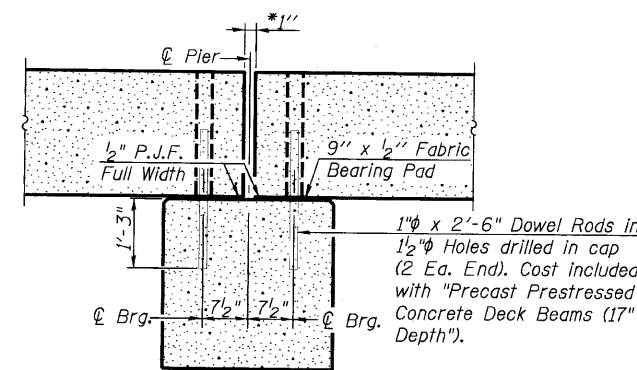

SECTION THRU PIER

Notes : After beams have been erected, holes shall be drilled into substructure and anchor dowels placed. Dowel holes shall be filled with non-shrink grout to top of beam and allowed to cure min. 24 hrs. prior to grouting the shear keys.
 * All horizontal dimensions are at right angles to beam ends.
 * 1" joint shall be filled with non-shrink grout.
 * 1" dimension may vary to accommodate tolerance in beam lengths.

Note: Connect beams in pairs with the transverse tie configuration shown.

NOTES

Prestressing steel shall be uncoated high strength, low relaxation 7-wire strand, Grade 270. The nominal diameter shall be 1/2" and the nominal cross-sectional area shall be 0.153 sq. in. The 1" rods in the transverse tie assembly shall be tightened to a snug fit and the threads set. Pockets on exterior faces of bridge shall be filled with grout after transverse tie assembly is in place.
 Reinforcement bars shall conform to ASTM A 706, Grade 60. (See Special Provisions).
 Two 1/8" fabric adjusting shims of the dimensions of the exterior bearing pad shall be provided for each bearing pad location.
 A minimum 2 1/2" diameter lifting pin shall be used to engage the lifting loops during handling.
 Corrosion Inhibitor, per Article 1020.05(b)(12) and 1021.06 of the Standard Specifications, shall be used in the concrete for precast prestressed concrete deck beams.
 Compressive strength of prestressed concrete, f'c, shall be 6000 psi.
 Compressive strength of prestressed concrete at release, f'ci, shall be 5000 psi.

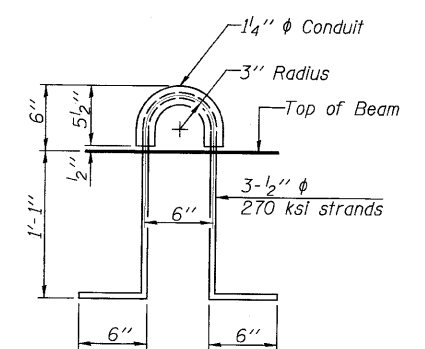

LIFTING LOOP DETAIL

BILL OF MATERIAL

Precast Prestressed Conc. Deck Bms. (17" depth)	Sq. Ft.	1054
---	---------	------

PD-1736-RD

11-1-09

FILE NAME =	USER NAME = USER#	DESIGNED -	REVISED -	Allen Henderson & Associates, Inc. Civil and Structural Engineers Springfield, IL. 62703 Phone: (217)544-8033 IL. Design Firm No. 184-001907	17" x 36" PPC DECK BEAM SPAN 2		T.R. RTE.	SECTION	COUNTY	TOTAL SHEETS	SHEET NO.
PLOT SCALE =	SCALE#	DRAWN -	REVISED -				303	09-11118-00-BR	SHELBY	22	10
CHECKED -	SCALE#	REVISOR -	REVISED -				CONTRACT NO. 95629				
DATE	DATE#	REVISOR -	REVISED -				FED. ROAD DIST. NO.			ILLINOIS	FED. AID PROJECT