

INDEX OF SHEETS

- 1. COVER SHEET
- 2. GENERAL NOTES
- 3 - 5. SUMMARY OF QUANTITIES
- 6. EXAMPLE WORK SHEET
- 7. PAVEMENT MARKING SUMMARY
- 8 - 15. PAVEMENT MARKING DETAILS

STANDARDS

- 701006-05 OFF-ROAD OPERATIONS 2L, 2W, 15' (4.5 m) TO 24" (600 mm) FROM PAVEMENT EDGE
- 701101-05 OFF-ROAD OPERATIONS, MULTILANE, 15' (4.5 m) TO 24" (600 mm) FROM PAVEMENT EDGE
- 701106-02 OFF-RD OPERATIONS, MULTILANE, MORE THAN 15' (4.5 m) AWAY
- 701201-05 LANE CLOSURE, 2L, 2W, DAY ONLY, FOR SPEEDS \geq 45 MPH
- 701301-04 LANE CLOSURE, 2L, 2W, SHORT TIME OPERATIONS
- 701311-03 LANE CLOSURE 2L, 2W MOVING OPERATIONS-DAY ONLY
- 701400-10 APPROACH TO LANE CLOSURE, FREEWAY/EXPRESSWAY
- 701401-12 LANE CLOSURE, FREEWAY/EXPRESSWAY
- 701406-12 LANE CLOSURE, FREEWAY/EXPRESSWAY, DAY OPERATIONS ONLY
- 701411-09 LANE CLOSURE, MULTILANE, AT ENTRANCE OR EXIT RAMP FOR SPEEDS \geq 45 MPH
- 701426-09 LANE CLOSURE, MULTILANE INTERMITTENT OR MOVING OPERATION, FOR SPEEDS \geq 45 MPH
- 701427-05 LANE CLOSURE, MULTILANE INTERMITTENT OR MOVING OPERATION, FOR SPEEDS \leq 40 MPH
- 701428-01 TRAFFIC CONTROL, SETUP AND REMOVAL, FREEWAY/EXPRESSWAY
- 701501-06 URBAN LANE CLOSURE, 2L, 2W, UNDIVIDED
- 701502-09 URBAN LANE CLOSURE, 2L, 2W, WITH BIDIRECTIONAL LEFT TURN LANE
- 701601-09 URBAN LANE CLOSURE, MULTILANE, 1W OR 2W WITH NONTRAVERSABLE MEDIAN
- 701602-10 URBAN LANE CLOSURE, MULTILANE, 2W WITH BIDIRECTIONAL LEFT TURN LANE
- 701701-10 URBAN LANE CLOSURE, MULTILANE INTERSECTION
- 701901-08 TRAFFIC CONTROL DEVICES

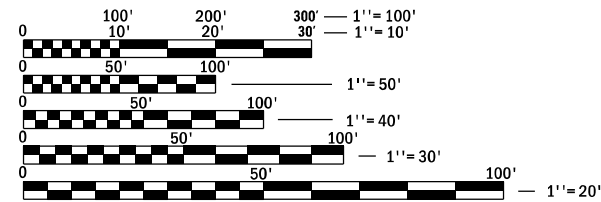

FULL SIZE PLANS HAVE BEEN PREPARED USING STANDARD ENGINEERING SCALES. REDUCED SIZED PLANS WILL NOT CONFORM TO STANDARD SCALES. IN MAKING MEASUREMENTS ON REDUCED PLANS, THE ABOVE SCALES MAY BE USED.

J.U.L.I.E.
JOINT UTILITY LOCATION INFORMATION FOR EXCAVATION
1-800-892-0123
OR 811

PROJECT ENGINEER: YOGESH PATEL P.E.
UNIT CHIEF: RON WOODSHANK
DISTRICT 3 NO. (815) 434-6131
CONTRACT NO. 46583

STATE OF ILLINOIS
DEPARTMENT OF TRANSPORTATION

PROPOSED
HIGHWAY PLANS

VARIOUS ROUTES
SECTION D3 HT PVMNT MRK RPR 22-19
HIGH TYPE PAVEMENT MARKING
VARIOUS COUNTIES



ROUTE	SECTION	COUNTY	TOTAL SHEETS	SHEET NO.
VARIOUS	D3 HT PVMNT MRK RPR 22-19	VARIOUS	15	1
		ILLINOIS	CONTRACT NO. 46583	

D-93-056-21

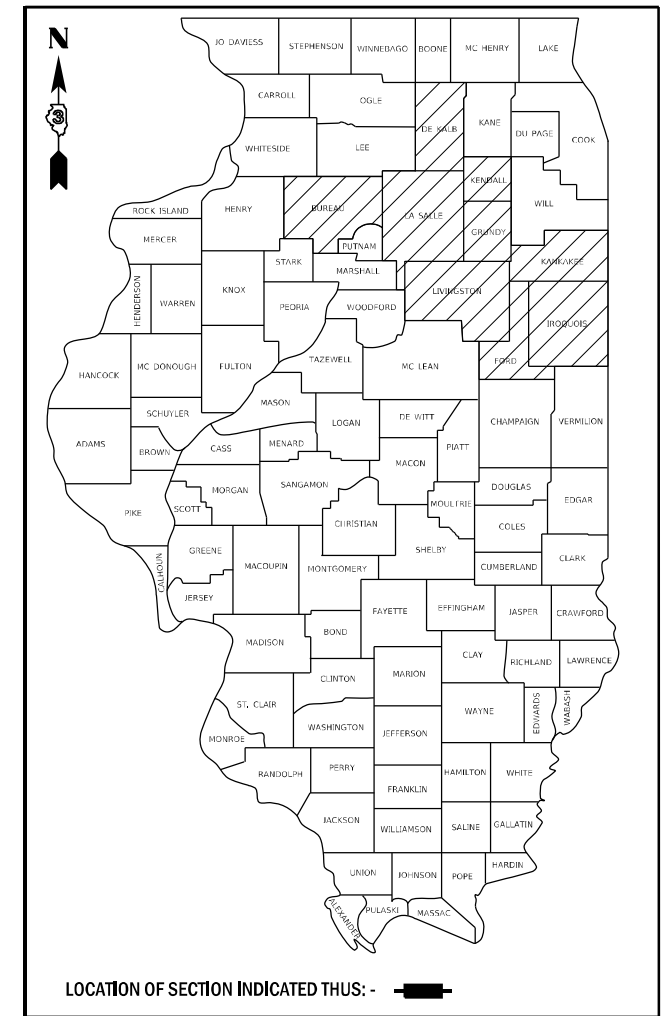

STATE OF ILLINOIS
DEPARTMENT OF TRANSPORTATION

SUBMITTED 5/7 20 21

Masood Ahmad REGIONAL ENGINEER

October 1, 2021
[Signature]
ENGINEER OF DESIGN AND ENVIRONMENT

October 21, 2021
[Signature]
DIRECTOR OF HIGHWAYS PROJECT IMPLEMENTATION

PRINTED BY THE AUTHORITY
OF THE STATE OF ILLINOIS

GENERAL NOTES

PLAN DIMENSIONS AND DETAILS RELATIVE TO EXISTING PLANS ARE SUBJECT TO NOMINAL CONSTRUCTION VARIATIONS. THE CONTRACTOR SHALL FIELD VERIFY EXISTING DIMENSIONS AND DETAILS AFFECTING NEW CONSTRUCTION AND MAKE NECESSARY APPROVED ADJUSTMENTS PRIOR TO CONSTRUCTION OR ORDERING OF MATERIALS. SUCH VARIATIONS SHALL NOT BE CAUSE FOR ADDITIONAL COMPENSATION FOR A CHANGE IN SCOPE OF WORK; HOWEVER, THE CONTRACTOR WILL BE PAID FOR THE QUANTITY ACTUALLY FURNISHED AT THE UNIT PRICE BID FOR THE WORK.

FOR STABILIZATION, ALL TYPE III BARRICADES WILL REQUIRE A MINIMUM OF FOUR SAND BAGS PER BARRICADE.

ANY REFERENCE TO A STANDARD IN THESE PLANS SHALL BE INTERPRETED TO MEAN THE EDITION AS INDICATED BY THE SUBNUMBER SHOWN IN THE LIST OF STANDARDS OR THE COPY INCLUDED IN THESE PLANS.

COMMITMENTS

STATE OF ILLINOIS
DEPARTMENT OF TRANSPORTATION
DISTRICT THREE
AS BUILT INFORMATION

SUPERVISING CONSTRUCTION FIELD ENGINEER

RESIDENT ENGINEER / TECHNICIAN

START & END DATES
OF CONSTRUCTION:

INSPECTORS:

STATE OF ILLINOIS
DEPARTMENT OF TRANSPORTATION
DISTRICT THREE

PREPARED BY: _____
DISTRICT STUDIES & PLANS ENGINEER

DATE: _____

EXAMINED BY: _____
DISTRICT CONSTRUCTION ENGINEER

DISTRICT MATERIALS ENGINEER

DISTRICT OPERATIONS ENGINEER

FILE NAME =	USER NAME = woodshankr1	DESIGNED - EM	REVISED -
p:\planroom.dot.illinois.gov\PIDOT\Documents\IDOT Offices\District 3\Projects\0346583\0346583-PLAN.dgn		CHECKED - RW	REVISED -
Default	PLOT SCALE = 100.0000' / in.	DATE - 7/2/19	REVISED -

**STATE OF ILLINOIS
DEPARTMENT OF TRANSPORTATION**

GENERAL NOTES

SCALE: SHEET 1 OF 1 SHEETS STA. TO STA.

ROUTE	SECTION	COUNTY	TOTAL SHEETS	SHEET NO.
VARIOUS	D3 HT PVMNT MRK RPR 22-19	VARIOUS	15	2
			CONTRACT NO. 46583	
		ILLINOIS	FED. AID PROJECT	

CODE NO.	ITEM	UNIT	TOTAL QUANTITY	CONSTRUCTION CODE	
				100% STATE	
				PAVEMENT MARKING	
				0021	
78000100	THERMOPLASTIC PAVEMENT MARKING - LETTERS AND SYMBOLS	SQ FT	2000	2000	
78000200	THERMOPLASTIC PAVEMENT MARKING - LINE 4"	FOOT	4900	4900	
78000400	THERMOPLASTIC PAVEMENT MARKING - LINE 6"	FOOT	1000	1000	
78000500	THERMOPLASTIC PAVEMENT MARKING - LINE 8"	FOOT	3000	3000	
78000600	THERMOPLASTIC PAVEMENT MARKING - LINE 12"	FOOT	1000	1000	
78000650	THERMOPLASTIC PAVEMENT MARKING - LINE 24"	FOOT	1000	1000	
78001100	PAINT PAVEMENT MARKING - LINE 4"	FOOT	135000	135000	
78001130	PAINT PAVEMENT MARKING - LINE 6"	FOOT	50000	50000	
78008210	POLYUREA PAVEMENT MARKING TYPE I - LINE 4"	FOOT	975000	975000	
78008230	POLYUREA PAVEMENT MARKING TYPE I - LINE 6"	FOOT	124000	124000	
78008240	POLYUREA PAVEMENT MARKING TYPE I - LINE 8"	FOOT	35000	35000	
78009000	MODIFIED URETHANE PAVEMENT MARKING - LETTERS AND SYMBOLS	SQ FT	8000	8000	
78009004	MODIFIED URETHANE PAVEMENT MARKING - LINE 4"	FOOT	750000	750000	
78009006	MODIFIED URETHANE PAVEMENT MARKING - LINE 6"	FOOT	80000	80000	

FILE NAME =	USER NAME = woodshankr1	DESIGNED - EM	REVISED -
p:\planning\dot.illinois.gov\PIWIDOT\Documents\IDOT Offices\District 3\Projects\0346583\0346583-PLAN.dgn		03/04/19	03/04/19
Default	PLOT SCALE = 100.0000' / in.	CHECKED - RW	REVISED -
	PLOT DATE = 4/27/2021	DATE - 7/2/19	REVISED -

**STATE OF ILLINOIS
DEPARTMENT OF TRANSPORTATION**

SUMMARY OF QUANTITIES

SCALE: SHEET 1 OF 3 SHEETS STA. TO STA.

ROUTE	SECTION	COUNTY	TOTAL SHEETS	SHEET NO.
VARIOUS	D3 HT PVMNT MRK RPR 22-19	VARIOUS	15	3
			CONTRACT NO. 46583	
			ILLINOIS FED. AID PROJECT	

CODE NO.	ITEM	UNIT	TOTAL QUANTITY	CONSTRUCTION CODE	
				100% STATE	
				PAVEMENT MARKING	
				0021	
78009008	MODIFIED URETHANE PAVEMENT MARKING - LINE 8"	FOOT	60000	60000	
78009012	MODIFIED URETHANE PAVEMENT MARKING - LINE 12"	FOOT	8000	8000	
78009024	MODIFIED URETHANE PAVEMENT MARKING - LINE 24"	FOOT	3000	3000	
78300201	PAVEMENT MARKING REMOVAL - GRINDING	SQ FT	500	500	
78300202	PAVEMENT MARKING REMOVAL - WATER BLASTING	SQ FT	16000	16000	
X2700010	PREFORMED PLASTIC PAVEMENT MARKING, TYPE D - LINE 6"	FOOT	32000	32000	
X2700015	PREFORMED PLASTIC PAVEMENT MARKING, TYPE D - LINE 24"	FOOT	1000	1000	
X2700027	PREFORMED PLASTIC PAVEMENT MARKING, TYPE D - LINE 8", CONTRAST	FOOT	24000	24000	
X7800815	HOT SPRAY THERMOPLASTIC PAVEMENT MARKING LINE - 4 INCH	FOOT	200000	200000	
X7800835	HOT SPRAY THERMOPLASTIC PAVEMENT MARKING LINE - 6 INCH	FOOT	30000	30000	
X7800845	HOT SPRAY THERMOPLASTIC PAVEMENT MARKING LINE - 8 INCH	FOOT	5000	5000	
X7830068	GROOVING FOR RECESSED PAVEMENT MARKING, LETTERS, NUMBERS AND SYMBOLS	SQ FT	4000	4000	
X7830070	GROOVING FOR RECESSED PAVEMENT MARKING 5"	FOOT	30000	30000	
X7830074	GROOVING FOR RECESSED PAVEMENT MARKING 7"	FOOT	25000	25000	

FILE NAME =	USER NAME = woodshankr	DESIGNED - EM	REVISED -
p:\planroom\dot\illinois.gov\PIWIDOT\Documents\DOT Offices\District 3\Projects\I346583\CADData\I346583	DRAWN - EM	CHECKED - RW	REVISED -
Default	PLOT SCALE = 100,0000 ' / in.	DATE - 7/2/19	REVISED -
	PLOT DATE = 4/27/2021		

**STATE OF ILLINOIS
DEPARTMENT OF TRANSPORTATION**

SUMMARY OF QUANTITIES

SCALE: SHEET 2 OF 3 SHEETS STA. TO STA.

ROUTE	SECTION	COUNTY	TOTAL SHEETS	SHEET NO.
VARIOUS	D3 HT PVMNT MRK RPR 22-19	VARIOUS	15	4
ILLINOIS FED. AID PROJECT			CONTRACT NO. 46583	

CODE NO.	ITEM	UNIT	TOTAL QUANTITY	CONSTRUCTION CODE
				100% STATE
				PAVEMENT MARKING
				0021
X7E30076	GROOVING FOR RECESSED PAVEMENT MARKING 9"	FOOT	24000	24000
X7E30078	GROOVING FOR RECESSED PAVEMENT MARKING 13"	FOOT	500	500
X7E30090	GROOVING FOR RECESSED PAVEMENT MARKING 25"	FOOT	1000	1000
Z0C08758	AERIAL SPEED CHECK MARKING	FOOT	200	200

FILE NAME =	USER NAME = woodshankr	DESIGNED - EM	REVISED -	STATE OF ILLINOIS DEPARTMENT OF TRANSPORTATION	SUMMARY OF QUANTITIES	ROUTE	SECTION	COUNTY	TOTAL SHEETS	SHEET NO.
pww\planroom\dot\illinois.gov\PIWIDOT\Documents\DOT Offices\District 3\Projects\I346583\CADData\I346583	DRAWN - EM	REVISD -	VARIOUS			D3 HT PVMNT MRK RPR 22-19	VARIOUS	15	5	
Default	PLOT SCALE = 100,0000 ' / in.	CHECKED - RW	REVISD -			CONTRACT NO. 46583				
	PLOT DATE = 4/27/2021	DATE - 7/2/19	REVISD -			SCALE:	SHEET 3 OF 3 SHEETS	STA. TO STA.	ILLINOIS FED. AID PROJECT	

**WORK ORDER
D3 HT PVMNT MRK RPR 22-19**

WORK ORDER NUMBER _____ DATE OF ISSUE _____ ROUTE _____

LOCATION DESCRIPTION _____

CONTRACT NO. 46583 JOB NO. M-60-019-22

CODE NUMBER	ITEM	UNIT	QUANTITY	UNIT PRICE	ITEM COST
78000100	THERMOPLASTIC PAVEMENT MARKING - LETTERS AND SYMBOLS	SQ FT	2,000		
78000200	THERMOPLASTIC PAVEMENT MARKING - LINE 4"	FOOT	4,900		
78000400	THERMOPLASTIC PAVEMENT MARKING - LINE 6"	FOOT	1,000		
78000500	THERMOPLASTIC PAVEMENT MARKING - LINE 8"	FOOT	3,000		
78000600	THERMOPLASTIC PAVEMENT MARKING - LINE 12"	FOOT	1,000		
78000650	THERMOPLASTIC PAVEMENT MARKING - LINE 24"	FOOT	1,000		
78001110	PAINT PAVEMENT MARKING - LINE 4"	FOOT	135,000		
78001130	PAINT PAVEMENT MARKING - LINE 6"	FOOT	50,000		
78008210	POLYUREA PAVEMENT MARKING TYPE I - LINE 4"	FOOT	975,000		
78008230	POLYUREA PAVEMENT MARKING TYPE I - LINE 6"	FOOT	124,000		
78008240	POLYUREA PAVEMENT MARKING TYPE I - LINE 8"	FOOT	35,000		
78009000	MODIFIED URETHANE PAVEMENT MARKING - LETTERS AND SYMBOLS	SQ FT	8,000		
78009004	MODIFIED URETHANE PAVEMENT MARKING - LINE 4"	FOOT	750,000		
78009006	MODIFIED URETHANE PAVEMENT MARKING - LINE 6"	FOOT	80,000		
78009008	MODIFIED URETHANE PAVEMENT MARKING - LINE 8"	FOOT	60,000		
78009012	MODIFIED URETHANE PAVEMENT MARKING - LINE 12"	FOOT	8,000		
78009024	MODIFIED URETHANE PAVEMENT MARKING - LINE 24"	FOOT	3,000		
X0327979	PAVEMENT MARKING REMOVAL - GRINDING	SQ FT	500		
X0327980	PAVEMENT MARKING REMOVAL - WATER BLASTING	SQ FT	16,000		
X2700010	PREFORMED PLASTIC PAVEMENT MARKING, TYPE D - LINE 6"	FOOT	32,000		
X2700015	PREFORMED PLASTIC PAVEMENT MARKING, TYPE D - LINE 24"	FOOT	1,000		
X2700027	PREFORMED PLASTIC PAVEMENT MARKING, TYPE D - LINE 8", CONTRAST	FOOT	24,000		
X7800815	HOT SPRAY THERMOPLASTIC PAVEMENT MARKING LINE - 4 INCH	FOOT	200,000		
X7800835	HOT SPRAY THERMOPLASTIC PAVEMENT MARKING LINE - 6 INCH	FOOT	30,000		
X7800845	HOT SPRAY THERMOPLASTIC PAVEMENT MARKING LINE - 8 INCH	FOOT	5,000		
X7830068	GROOVING FOR RECESSED PAVEMENT MARKING, LETTERS, NUMBERS & SYMBOLS	SQ FT	4,000		
X7830070	GROOVING FOR RECESSED PAVEMENT MARKING 5"	FOOT	30,000		
X7830074	GROOVING FOR RECESSED PAVEMENT MARKING 7"	FOOT	25,000		
X7830076	GROOVING FOR RECESSED PAVEMENT MARKING 9"	FOOT	24,000		
X7830078	GROOVING FOR RECESSED PAVEMENT MARKING 13"	FOOT	500		
X7830090	GROOVING FOR RECESSED PAVEMENT MARKING 25"	FOOT	1,000		
Z0008758	AERIAL SPEED CHECK MARKING	FOOT	200		

DISTRICT CONTACT

NAME : _____ SUBMITTED BY : _____
REGIONAL ENGINEER

TELEPHONE NO. _____ DATE : _____

CELL PHONE NO. _____ APPROVED BY : _____
TRAFFIC ENGINEER OF OPERATIONS

DATE : _____

FILE NAME =	USER NAME = woodshank1	DESIGNED - EM	REVISED -	STATE OF ILLINOIS DEPARTMENT OF TRANSPORTATION	EXAMPLE WORK ORDER	ROUTE	SECTION	COUNTY	TOTAL SHEETS	SHEET NO.	
pw:\planroom.dot\illinois.gov\PWIDOT\Documents\IDOT	Offices\District 3\Projects\D346583\CADData\D346583-PLANS.dgn	DRAWN - EM	REVISED -			VARIOUS	D3 HT PVMNT MRK RPR 22-19	VARIOUS	15	6	
Default	PLOT SCALE = 100,0000' / in.	CHECKED - RW	REVISED -			CONTRACT NO. 46583					
	PLOT DATE = 4/27/2021	DATE - 7/2/19	REVISED -			SCALE:	SHEET 1 OF 1 SHEETS	STA.	TO STA.	ILLINOIS FED. AID PROJECT	

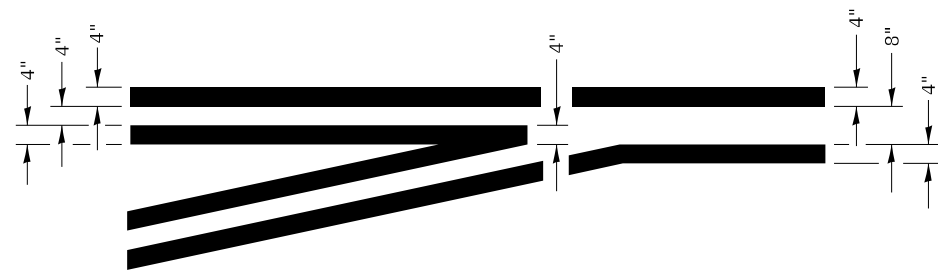

**LEFT TURN LANE
TYPICAL APPLICATION**

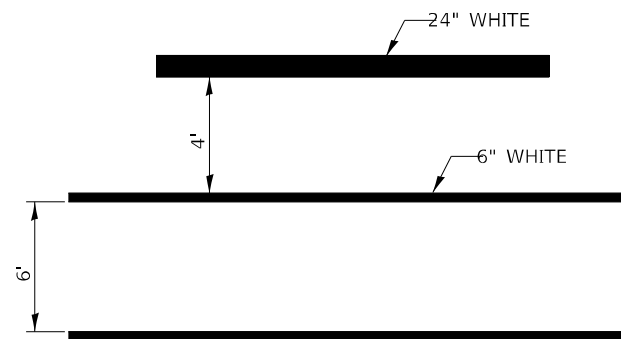

**TYPICAL SPACING DETAIL FOR
CROSSWALKS AND STOP BARS**

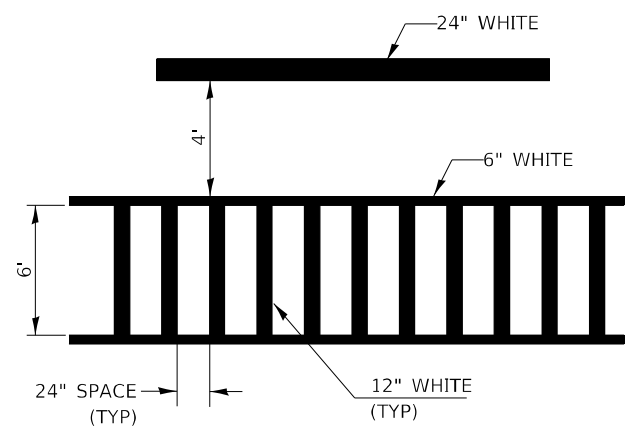

**TYPICAL SPACING DETAIL FOR
CROSSWALKS AND STOP BARS**

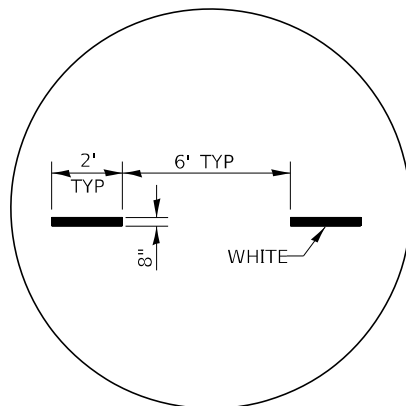

**ADVANCE AND INTERSECTION LANE
DIVIDER, INTERSTATE RAMP
TRANSITION LINES**

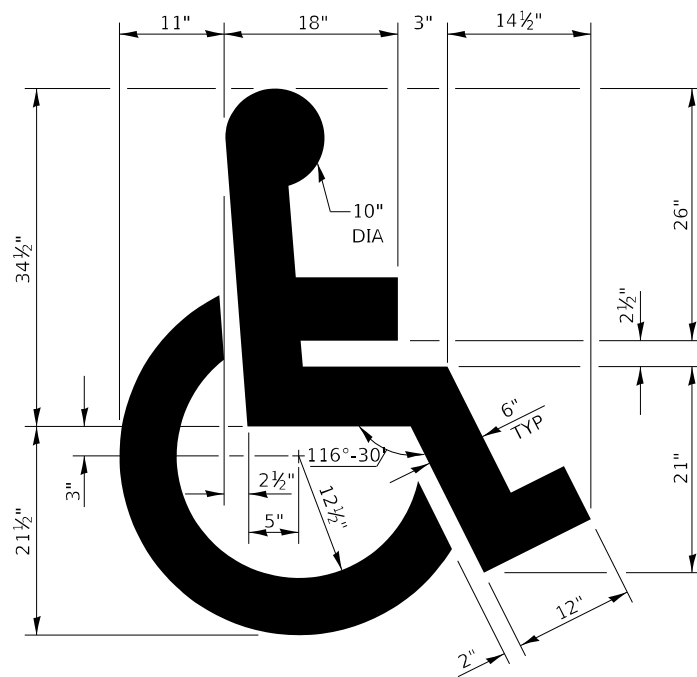

**TYPICAL DETAIL FOR
PAINTING HANDICAP MARKINGS**

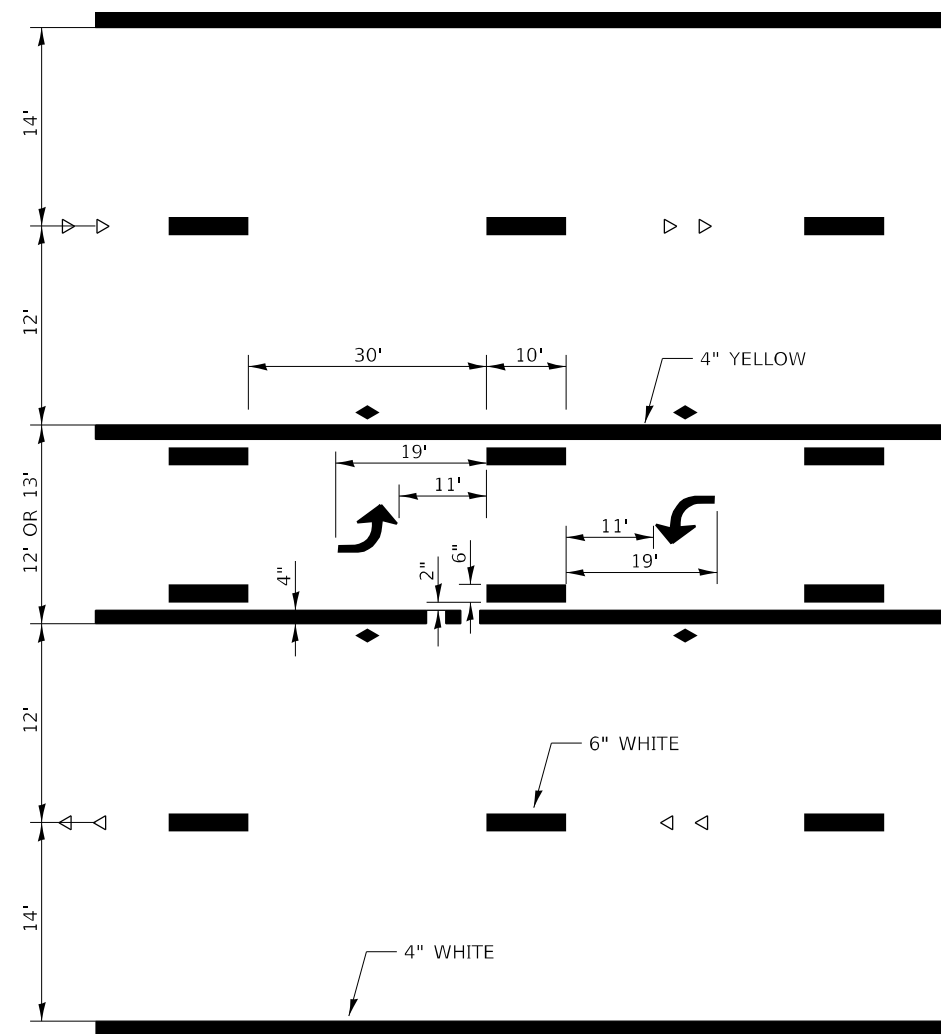

**TYPICAL APPLICATION @
TWO WAY LEFT TURN LANE (TWLTL)**

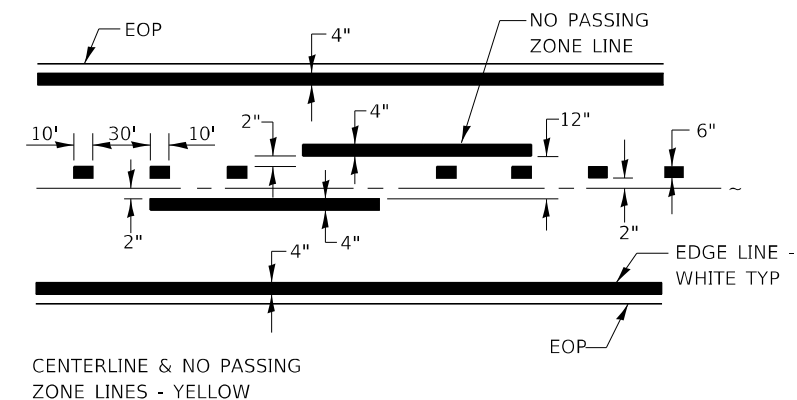

CENTERLINE & NO PASSING
ZONE LINES - YELLOW

PAVEMENT MARKING

FILE NAME =	USER NAME = woodshank1	DESIGNED - EM	REVISED -
pw:\planroom\dot\illinois\gov\PWIDOT\Documents\IDOT\Offices\District 3\Projects\D346568\CADData\D346568-PLANS.dgn		DRAWN - EM	REVISED -
Default	PLOT SCALE = 100,0000' / in.	CHECKED - RW	REVISED -
	PLOT DATE = 4/16/2021	DATE - 7/2/19	REVISED -

**STATE OF ILLINOIS
DEPARTMENT OF TRANSPORTATION**

PAVEMENT MARKING DETAILS

SCALE: SHEET 1 OF 8 SHEETS STA. TO STA.

ROUTE	SECTION	COUNTY	TOTAL SHEETS	SHEET NO.
VARIOUS	D3 HT PVMNT MRK RPR 22-19	VARIOUS	15	8
CONTRACT NO. 46583			ILLINOIS FED. AID PROJECT	

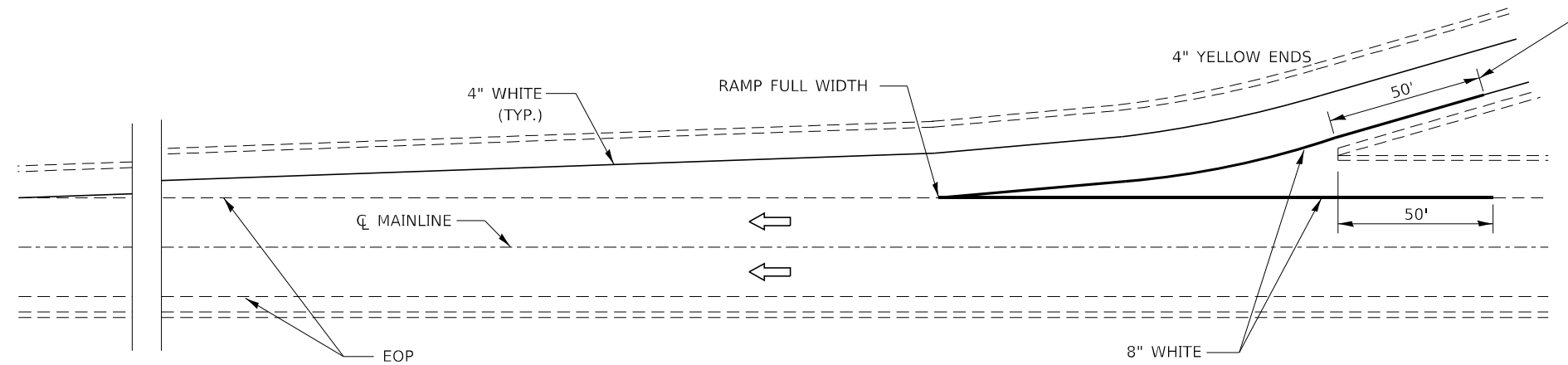

TYPICAL PAVEMENT MARKING FOR ENTRANCE RAMP TERMINALS

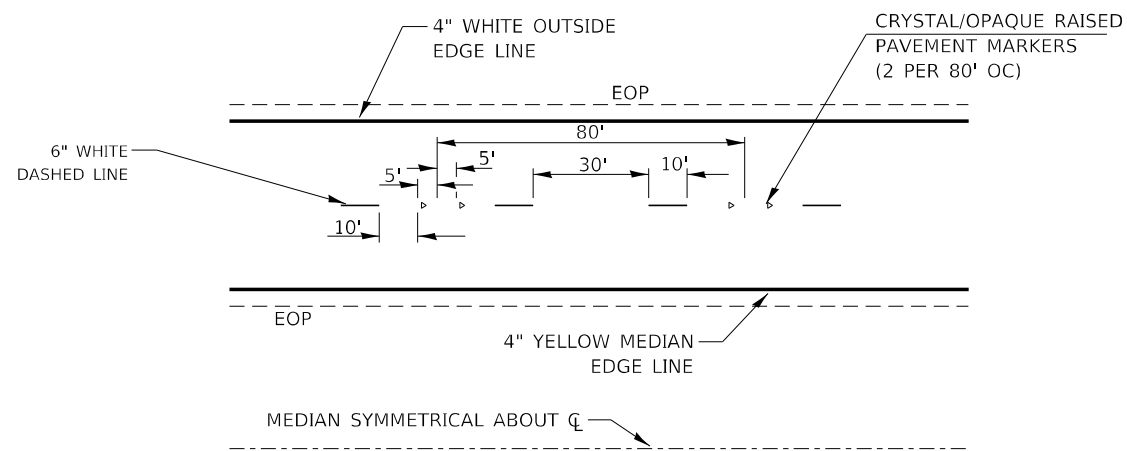

TYPICAL PAVEMENT MARKINGS

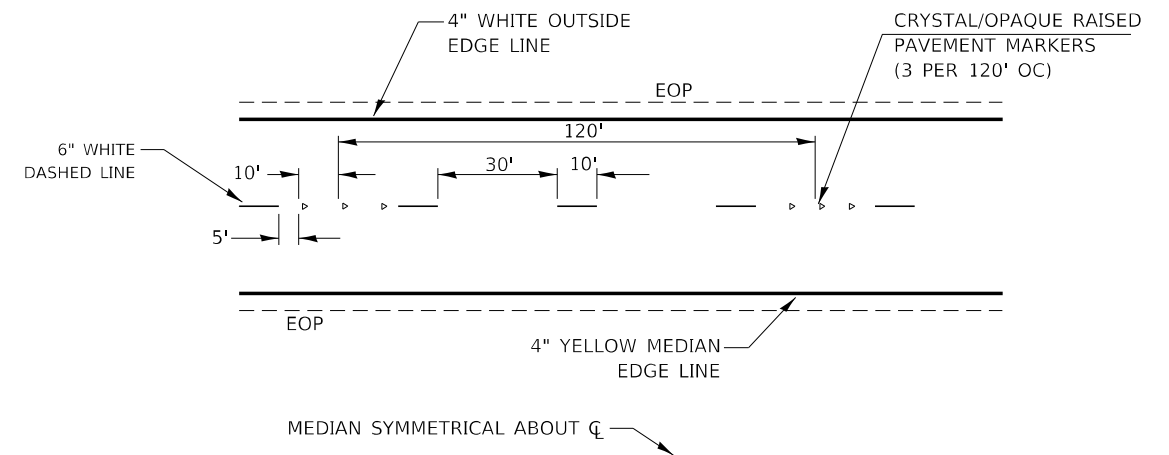

TYPICAL PAVEMENT MARKINGS FOR I-39 ONLY

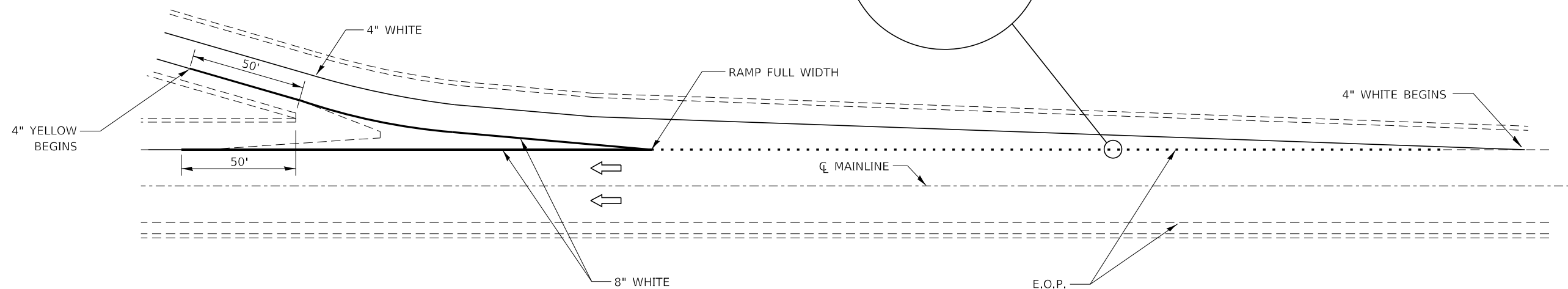
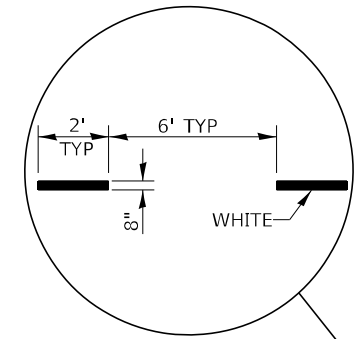

TYPICAL PAVEMENT MARKINGS FOR EXIT RAMP TERMINALS

FILE NAME =	USER NAME = woodshank1	DESIGNED - EM	REVISED -
pw:\planroom\dot\illinois.gov\PWIDOT\Documents\IDOT\	Offices\District 3\Projects\D346568\CADData\I346568-PLANS.dgn	DRAWN - EM	REVISED -
Default	PLOT SCALE = 100,0000' / in.	CHECKED - RW	REVISED -
	PLOT DATE = 4/16/2021	DATE - 7/2/19	REVISED -

**STATE OF ILLINOIS
DEPARTMENT OF TRANSPORTATION**

PAVEMENT MARKING DETAILS			
SCALE:	SHEET 2	OF 8 SHEETS	STA. TO STA.

ROUTE	SECTION	COUNTY	TOTAL SHEETS	SHEET NO.
VARIOUS	D3 HT PVMNT MRK RPR 22-19	VARIOUS	15	9
			CONTRACT NO. 46583	
ILLINOIS FED. AID PROJECT				

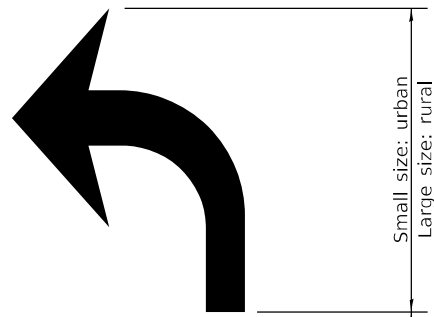

20' (6 m): urban
50' (15 m): rural
(Between arrow and word or between words)

ONLY

WORD AND ARROW LAYOUT

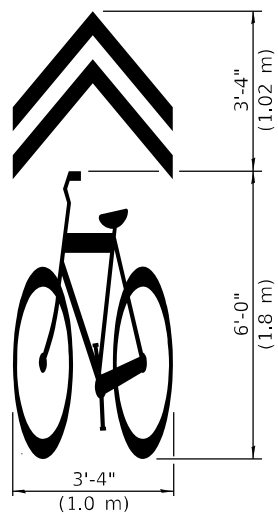

SHARED LANE SYMBOL

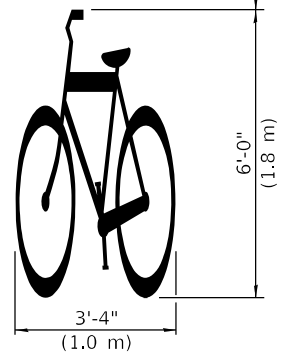
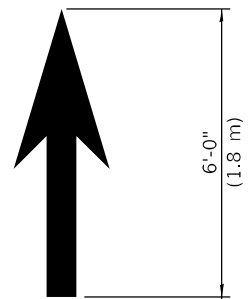

BIKE SYMBOL
(Arrow is optional.)

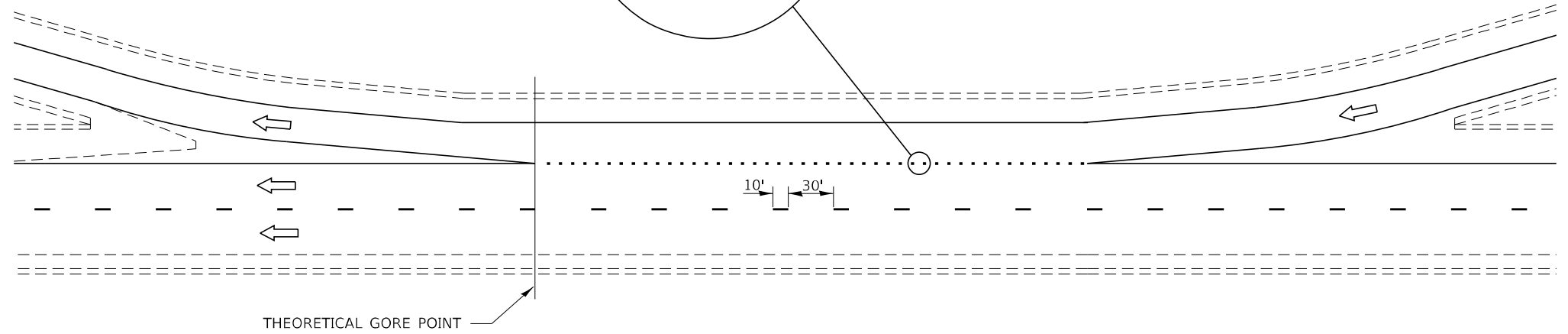
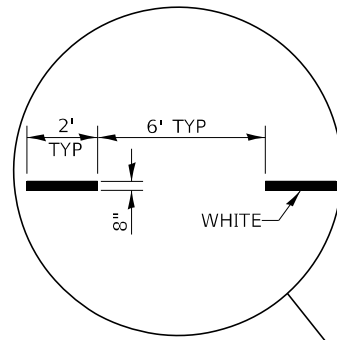

TYPICAL CLOVERLEAF LOOP RAMP MARKINGS

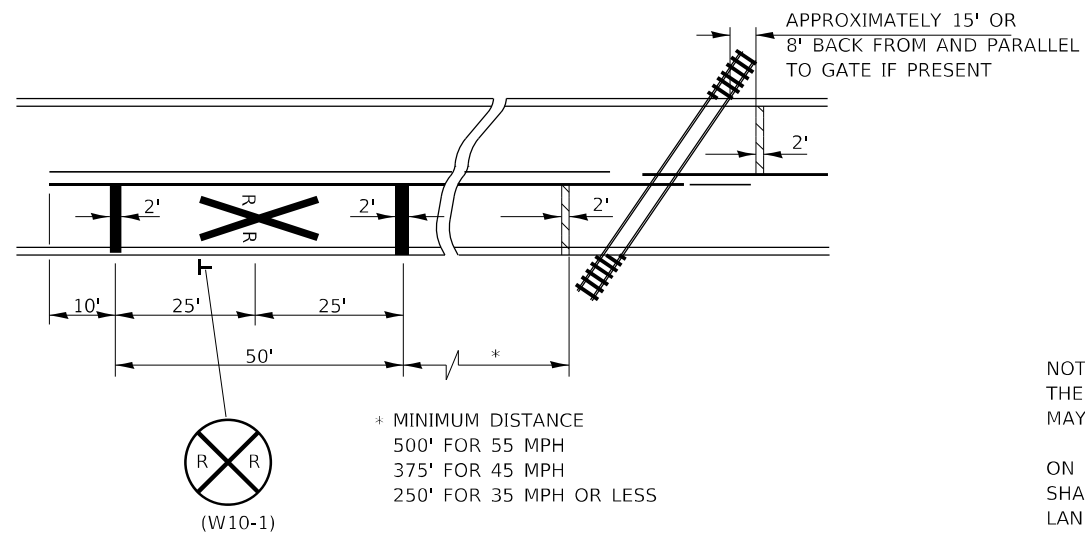

PAVEMENT MARKINGS AT RAILROAD-HIGHWAY GRADE CROSSING

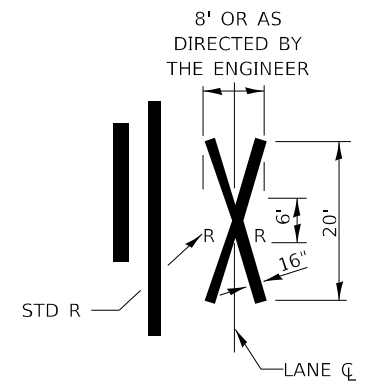

NOTES:
THE TRANSVERSE SPREAD OF THE "X" MAY VARY ACCORDING TO LANE WIDTH.
ON MULTI-LANE ROADS, THE STOP LINES SHALL EXTEND ACROSS ALL APPROACH LANES AND SEPARATE RXR SYMBOLS SHALL BE PLACED ADJACENT TO EACH OTHER IN EACH LANE.
WHEN THE PAVEMENT MARKING SYMBOL IS USED, A PORTION OF THE SYMBOL SHOULD BE LOCATED DIRECTLY ADJACENT TO THE ADVANCE WARNING SIGN (W10-1).

FILE NAME =	USER NAME = woodshank1	DESIGNED - EM	REVISED -
pw:\planroom\dottillinois.gov\PWIDOT\Documents\IDOT	Offices\District 3\Projects\ID346568\CADData\ID346568-PLANS.dgn	DRAWN - EM	REVISED -
Default	PLOT SCALE = 100,0000 / in.	CHECKED - RW	REVISED -
	PLOT DATE = 4/16/2021	DATE - 7/2/19	REVISED -

**STATE OF ILLINOIS
DEPARTMENT OF TRANSPORTATION**

PAVEMENT MARKING DETAILS			
SCALE:	SHEET 3 OF 8 SHEETS	STA.	TO STA.

ROUTE	SECTION	COUNTY	TOTAL SHEETS	SHEET NO.
VARIOUS	D3 HT PVMNT MRK RPR 22-19	VARIOUS	15	10
CONTRACT NO. 46583			ILLINOIS FED. AID PROJECT	

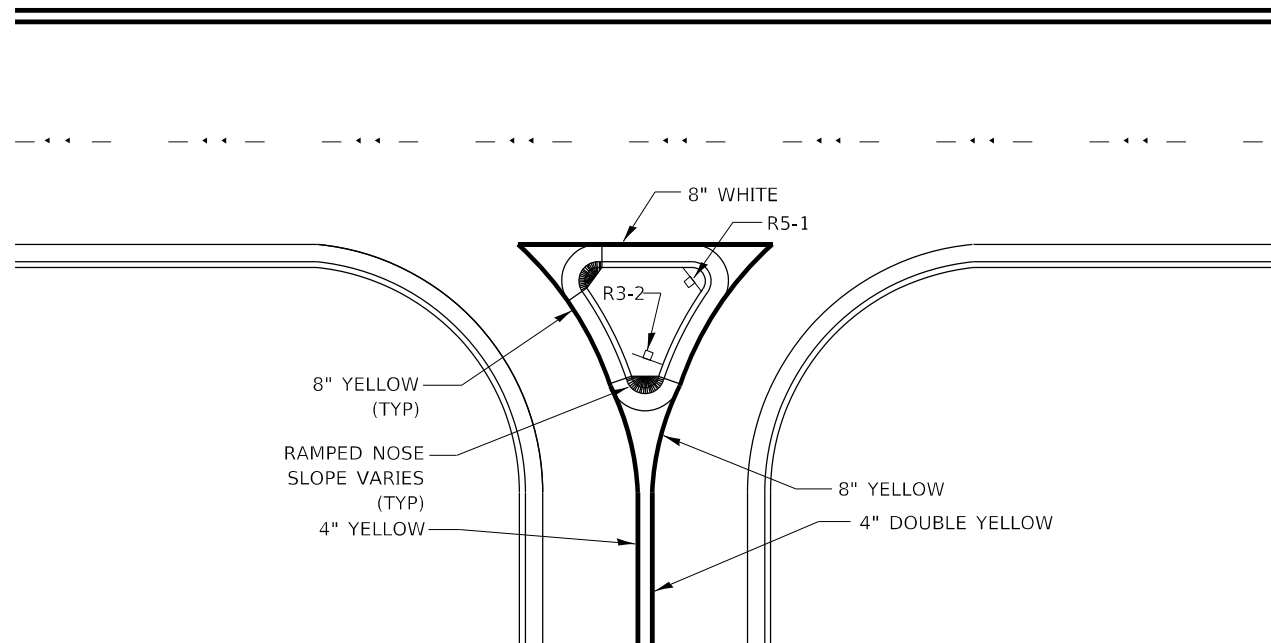

RIGHT IN RIGHT OUT ACCESS PAVEMENT MARKING

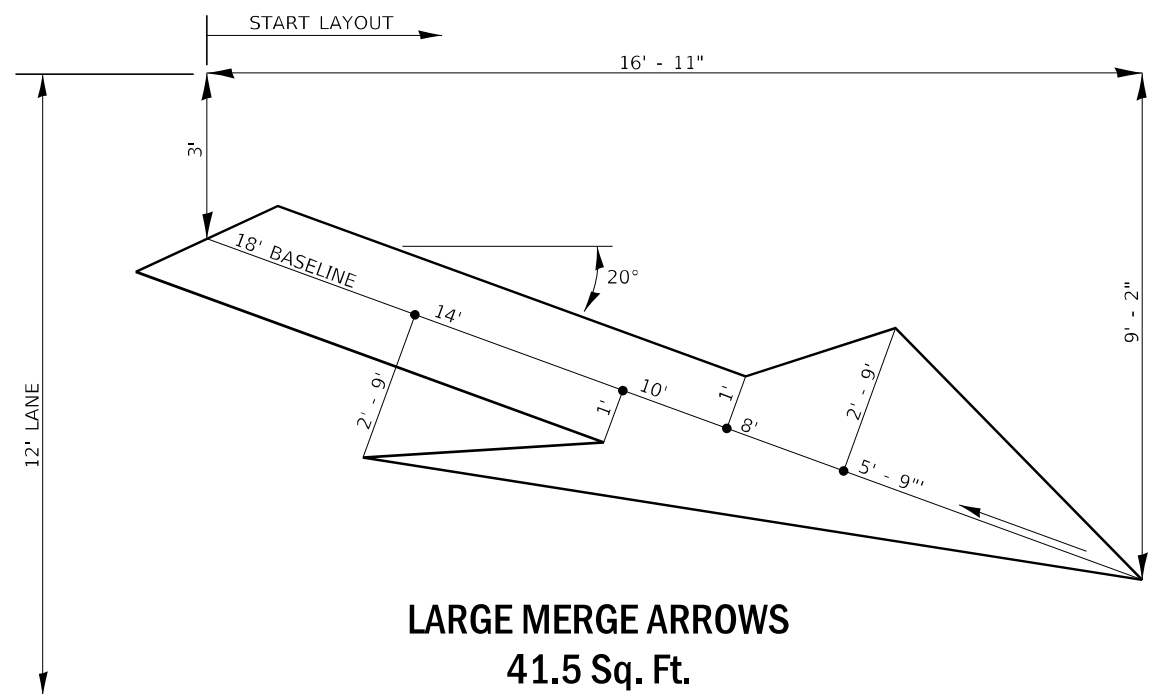

**LARGE MERGE ARROWS
41.5 Sq. Ft.**

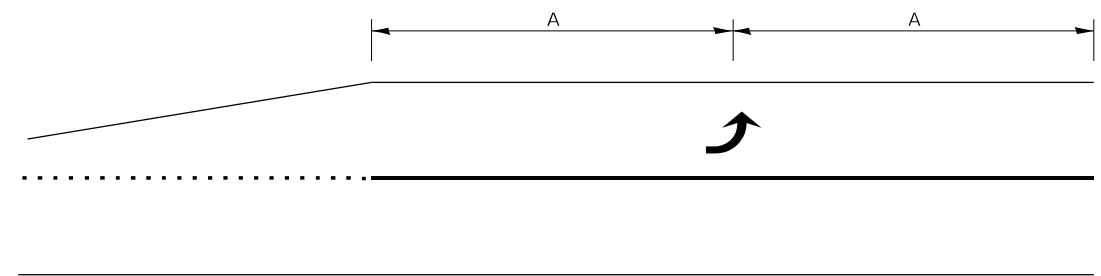

99' AND UNDER

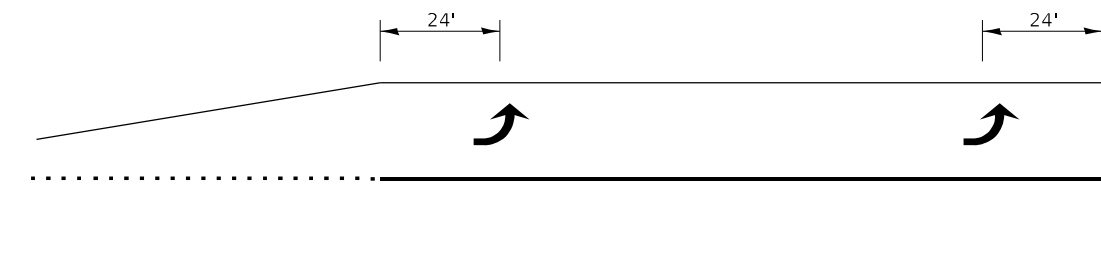

100' TO 149'

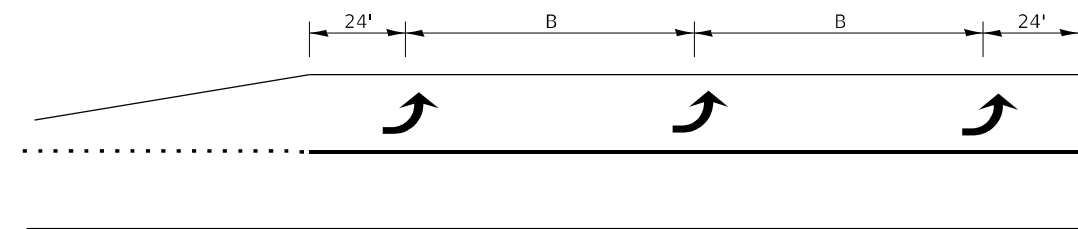

150' AND LONGER

**TYPICAL PLACEMENT OF ARROWS
IN TURN LANES**

FILE NAME =	USER NAME = woodshank1	DESIGNED - EM	REVISED -
pw:\planroom\dot\illinois.gov\PWIDOT\Documents\IDOT\Offices\District 3\Projects\D346568\CADData\D346568-PLANS.dgn		DRAWN - EM	REVISED -
Default	PLOT SCALE = 100,0000' / in.	CHECKED - RW	REVISED -
	PLOT DATE = 4/16/2021	DATE - 7/2/19	REVISED -

**STATE OF ILLINOIS
DEPARTMENT OF TRANSPORTATION**

PAVEMENT MARKING DETAILS

SCALE: SHEET 4 OF 8 SHEETS STA. TO STA.

ROUTE	SECTION	COUNTY	TOTAL SHEETS	SHEET NO.
VARIOUS	D3 HT PVMNT MRK RPR 22-19	VARIOUS	15	11
			CONTRACT NO. 46583	
		ILLINOIS	FED. AID PROJECT	

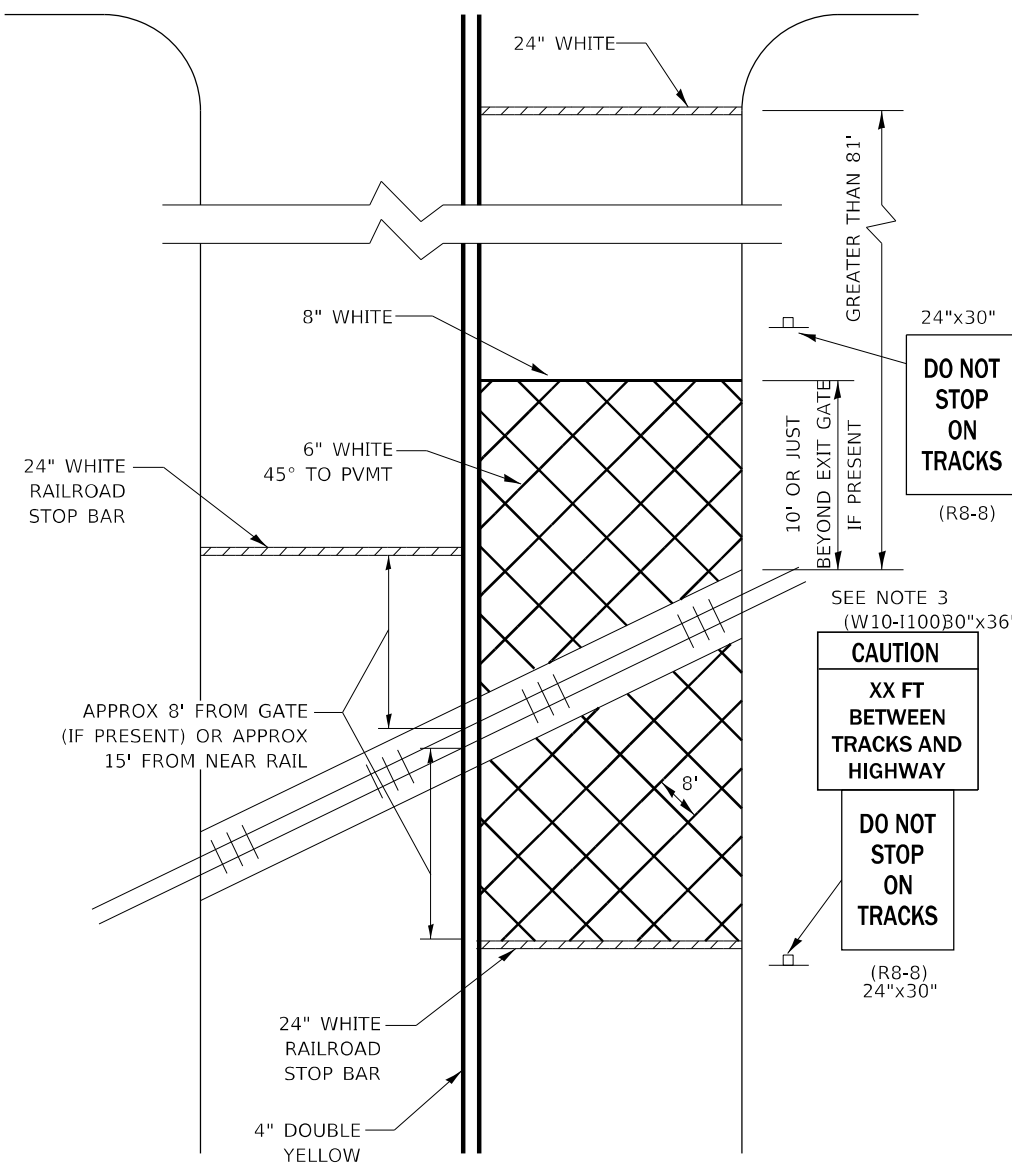

WITH INTERSECTION TRAFFIC SIGNALS

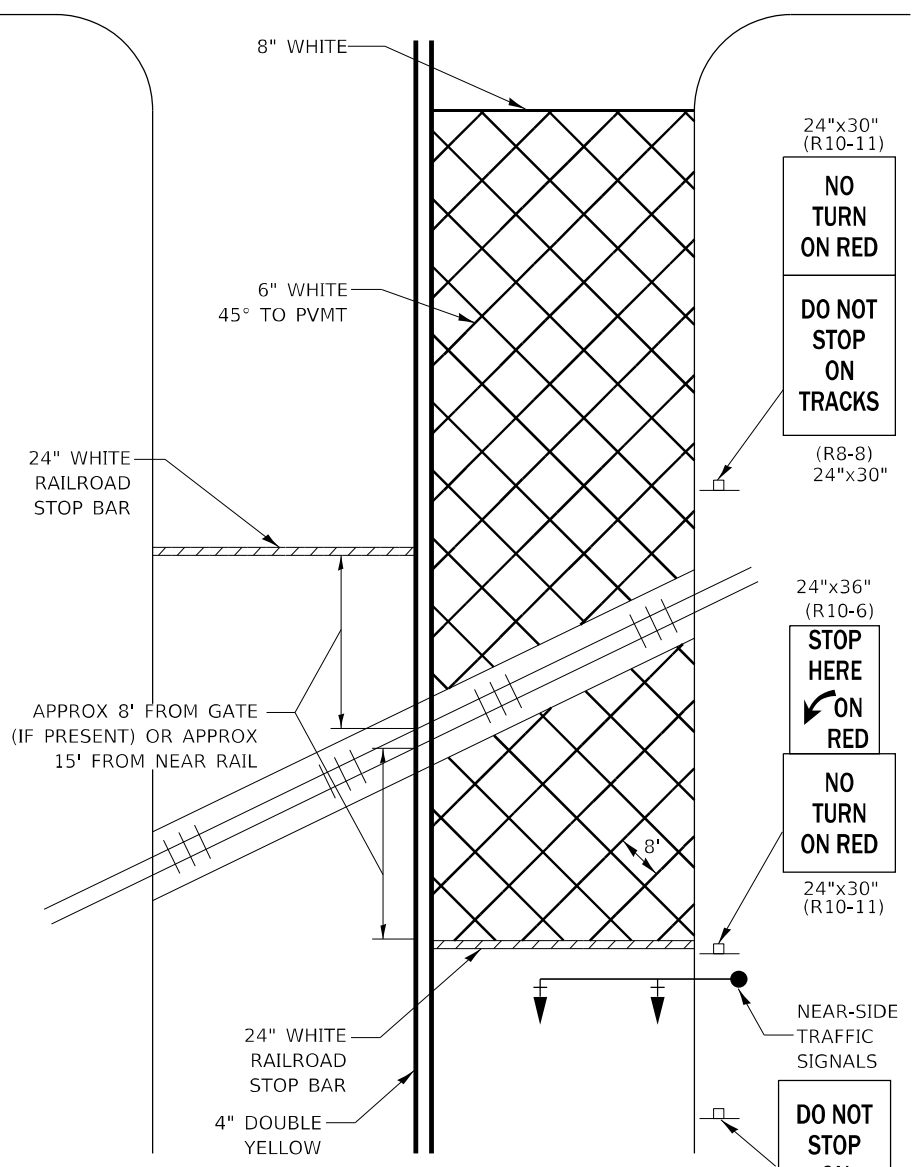

WITH NEAR-SIDE TRAFFIC SIGNALS

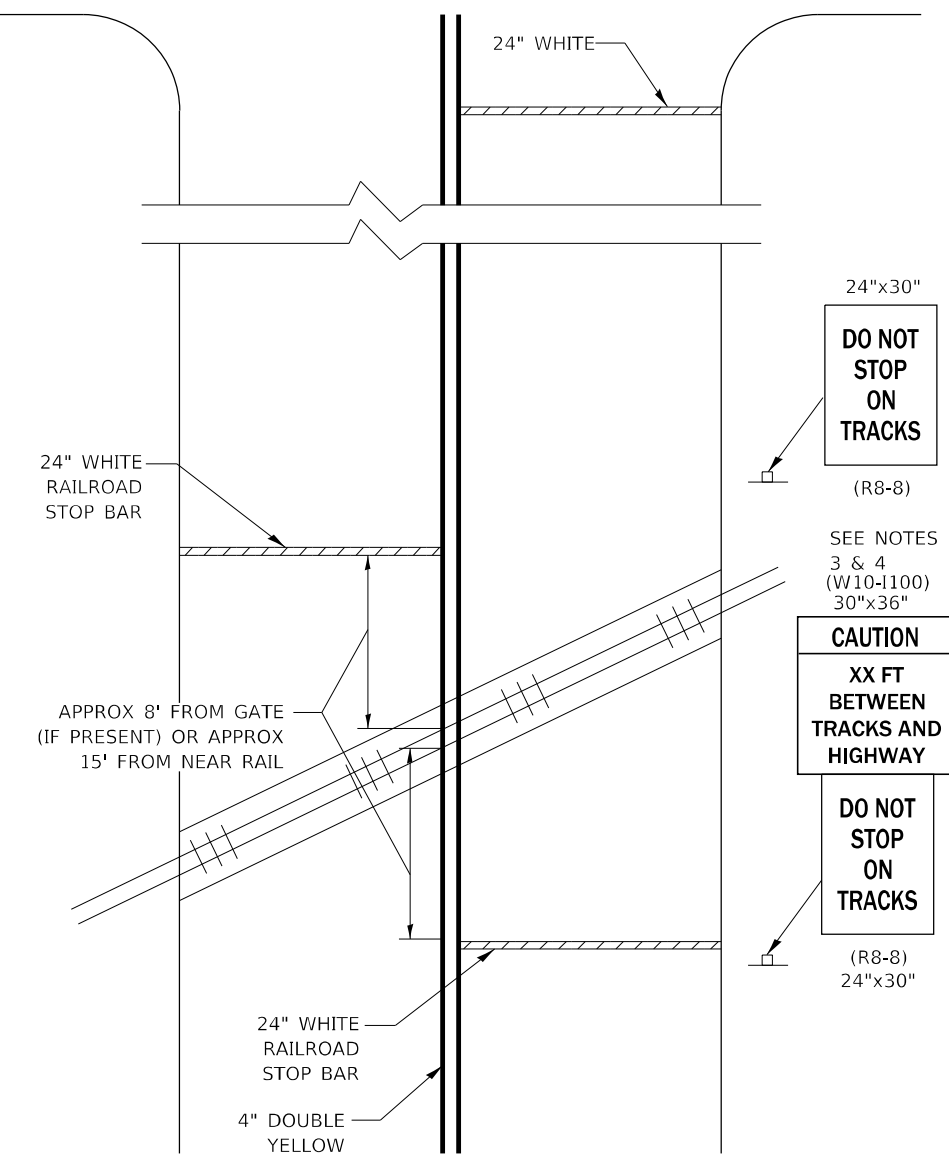

WITH NONSIGNALIZED INTERSECTION

- NOTE:
1. PAVEMENT MARKINGS TO BE INSTALLED ONLY ON APPROACHES TO INTERSECTIONS CONTROLLED BY TRAFFIC SIGNALS WHICH ARE INTERCONNECTED WITH THE RAILROAD WARNING SIGNALS.
 2. WHERE NEAR-SIDE TRAFFIC SIGNALS ARE USED THE PAVEMENT MARKINGS EXTEND TO THE INTERSECTION.
 3. DISTANCE TO BE SHOWN ON SIGN MEASURED FROM A POINT 6 FEET FROM THE RAIL CLOSEST TO THE INTERSECTION OR FROM THE CLOSEST POINT ALONG THE EXIT GATE IF PRESENT OVER THE ROADWAY WHEN IN THE LOWERED POSITION TO THE STOP BAR OR CROSSWALK, WHICH EVER IS CLOSEST, ROUNDED DOWN TO NEAREST 5 FEET. WHERE THERE IS NO STOP LINE, MEASURE TO POINT WHERE DRIVER HAS A VIEW OF APPROACHING TRAFFIC.
 4. THE CLEARANCE SIGN IS ALSO TO BE USED AS AN INTERIM MEASURE AT LOCATIONS WITH INTERCONNECTED INTERSECTION TRAFFIC SIGNALS WHERE IT IS PLANNED TO CHANGE THEM TO NEAR-SIDE SIGNALS AT A FUTURE TIME. IN THIS CASE, THE DISTANCE TO BE SHOWN ON THE SIGN IS MEASURED FROM THE EDGE OF THE STRIPED-OUT AREA INSTEAD OF 6 FEET FROM THE RAIL. THE SIGN IS TO BE REMOVED WHEN THE NEAR-SIDE SIGNALS ARE INSTALLED AND THE PAVEMENT MARKINGS EXTEND TO THE INTERSECTION.

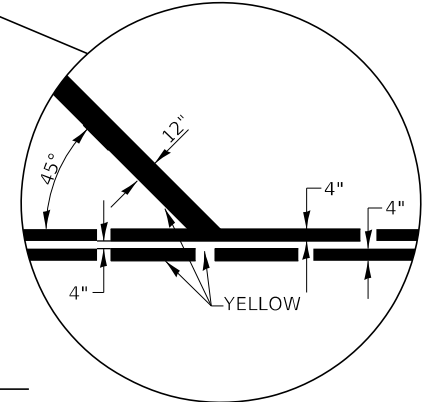
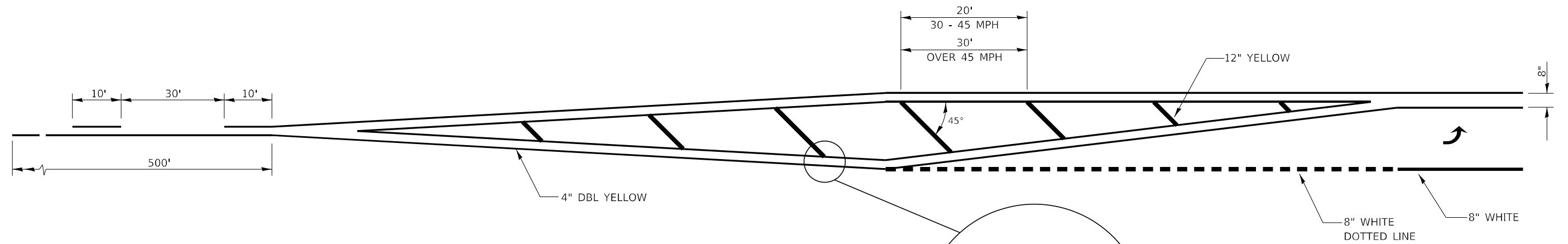

LEFT TURN LANE WITH APPROACH MEDIAN

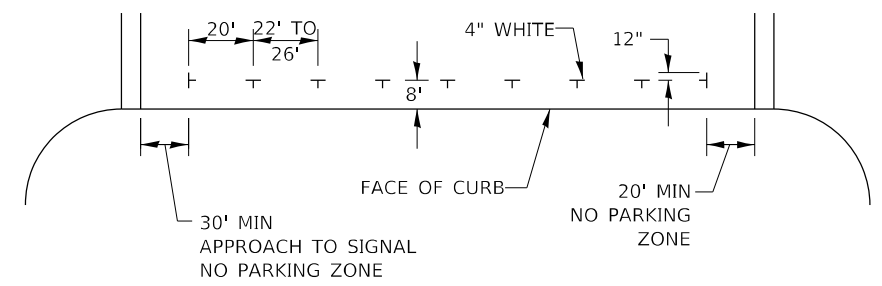

PREFERRED METHOD

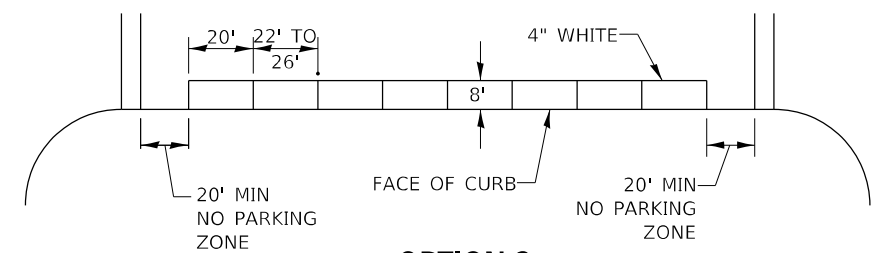

OPTION 2

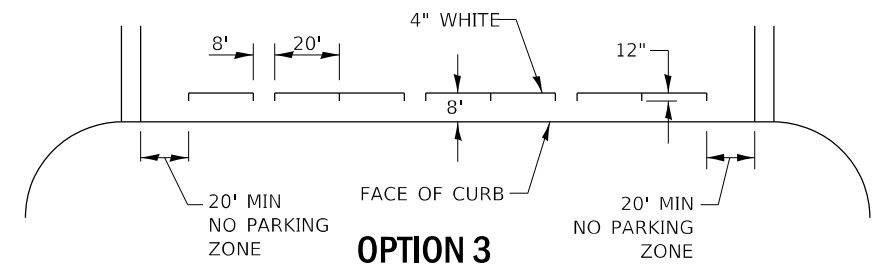

OPTION 3

TYPICAL PARKING SPACING

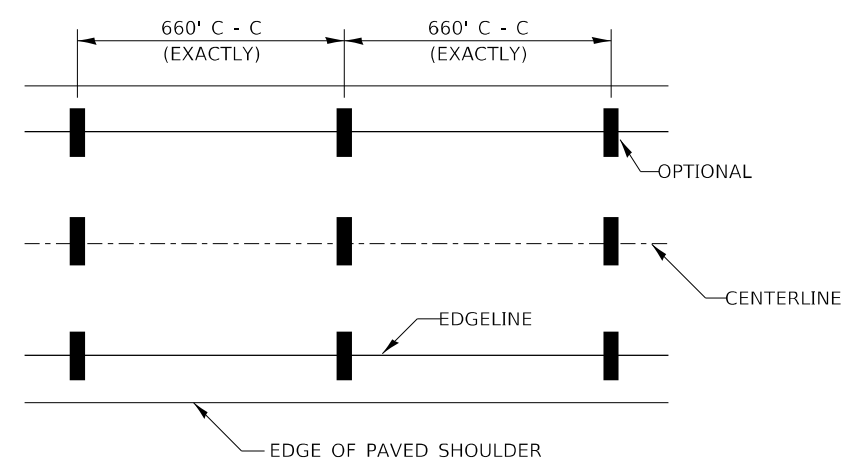

IT WILL BE NECESSARY TO HAVE A REPRESENTATIVE OF THE STATE POLICE PRESENT SO THAT THE ACCURACY OF MEASUREMENT CAN BE ATTESTED TO IN COURT.

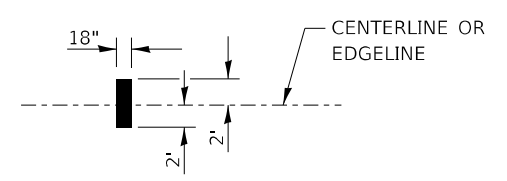

AERIAL SPEED CHECK ZONES

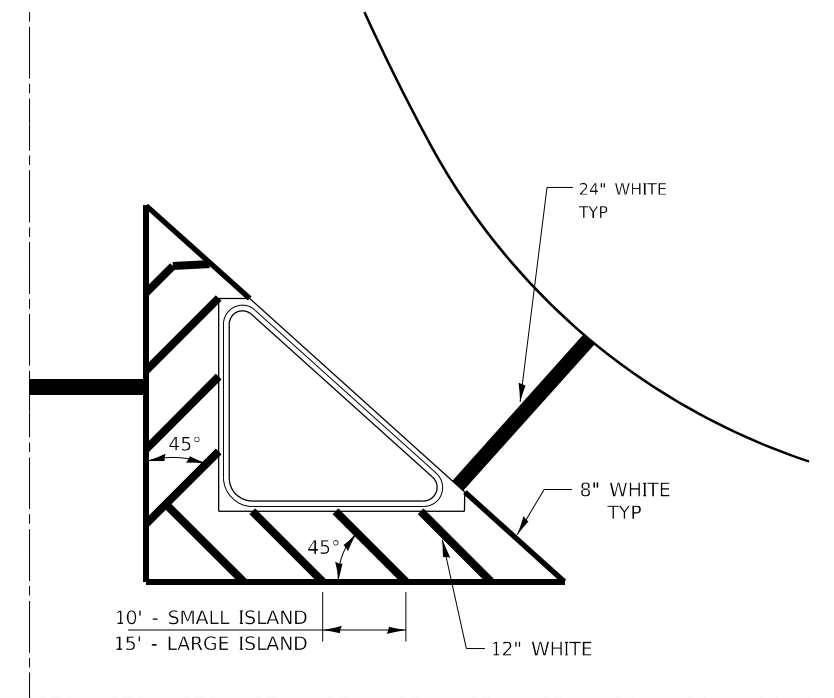

TYPICAL ISLAND

FILE NAME =	USER NAME = woodshank1	DESIGNED - EM	REVISED -	STATE OF ILLINOIS DEPARTMENT OF TRANSPORTATION	PAVEMENT MARKING DETAILS			ROUTE	SECTION	COUNTY	TOTAL SHEETS	SHEET NO.
pw\planroom\dot\illinois.gov\PWDOT\Documents\DOT Offices\District 3\Projects\D346568\CADData\D346568-PLANS.dgn	DRAWN - EM	REVISED -	VARIOUS					D3 HT PVMNT MRK RPR 22-19	VARIOUS	15	13	
Default	PLOT SCALE = 100,0000' / in.	CHECKED - RWV	REVISED -		SCALE: SHEET 6 OF 8 SHEETS STA. TO STA.			CONTRACT NO. 46583				
	PLOT DATE = 4/16/2021	DATE - 7/2/19	REVISED -					ILLINOIS FED. AID PROJECT				

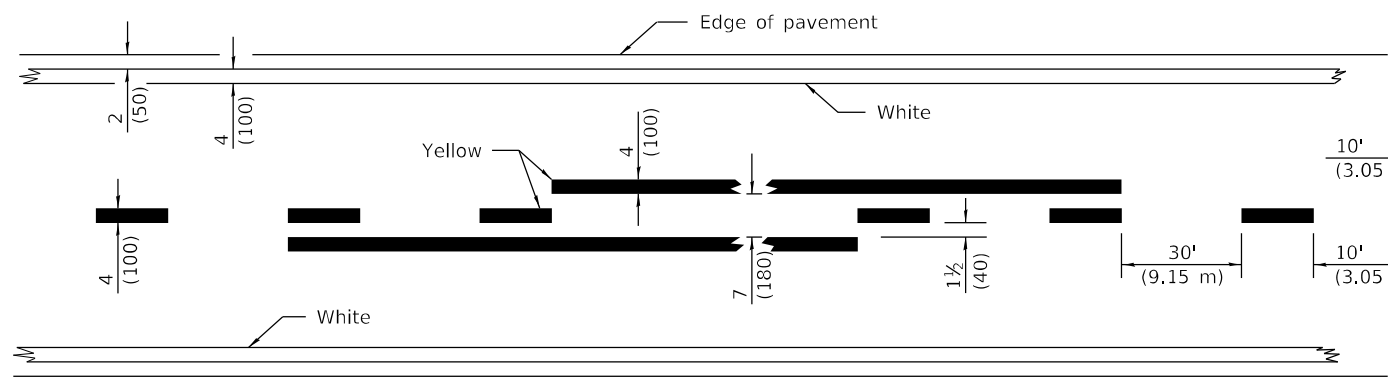

2 LANE

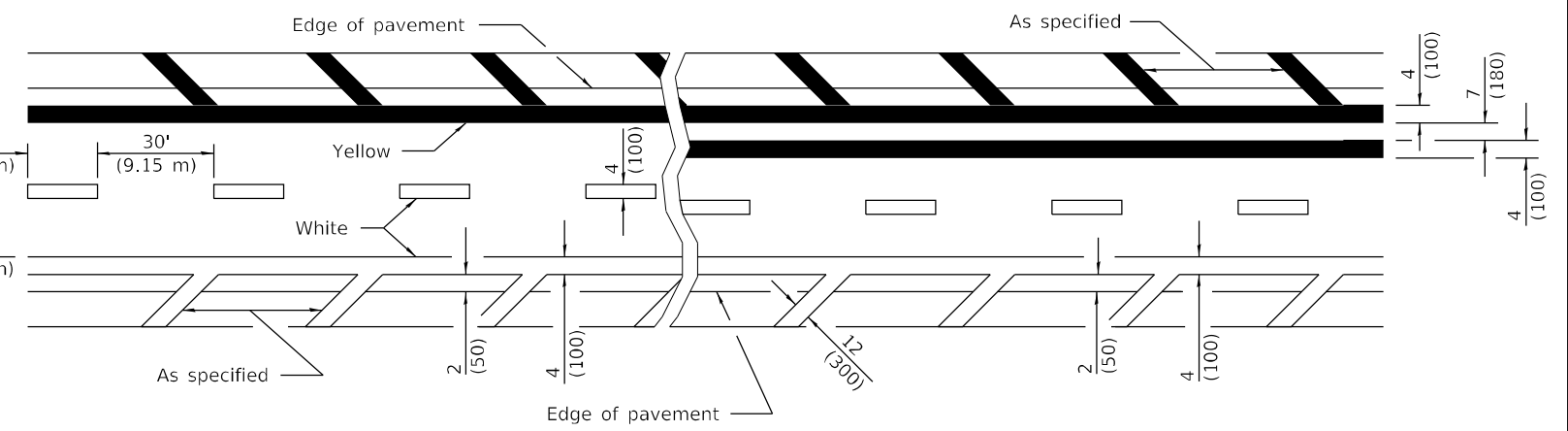

MULTI LANE

LANE AND EDGE LINES

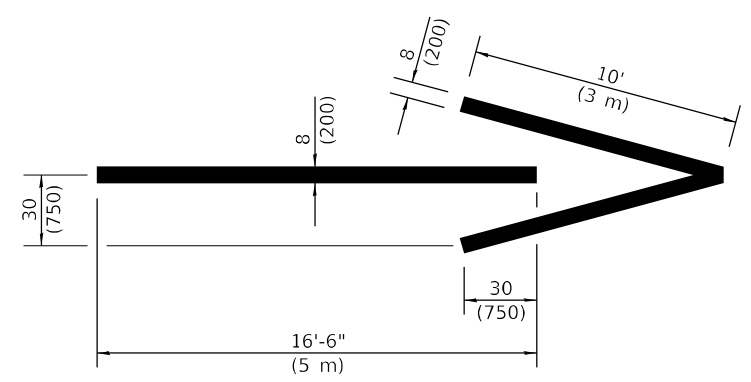

WRONG WAY ARROW

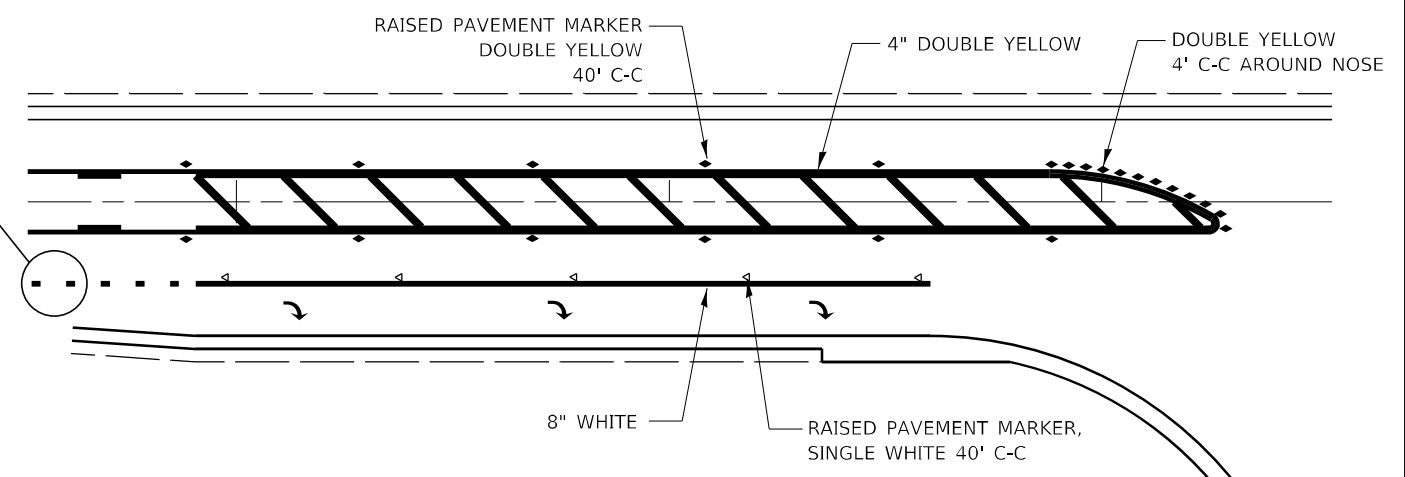
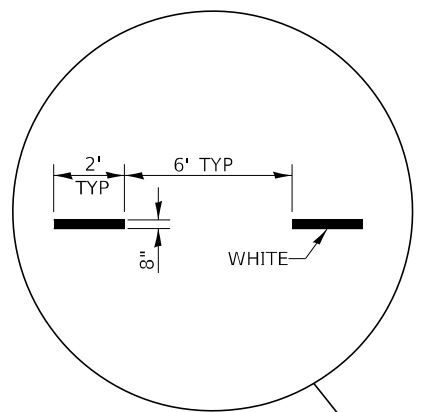

RAISED REFLECTIVE AND PAVEMENT MARKERS @ RIGHT TURN LANE

FILE NAME =	USER NAME = woodshank1	DESIGNED - EM	REVISED -	STATE OF ILLINOIS DEPARTMENT OF TRANSPORTATION	PAVEMENT MARKING DETAILS			ROUTE	SECTION	COUNTY	TOTAL SHEETS	SHEET NO.
pw:\planroom.dot\illinois.gov\PWIDOT\Documents\IDOT	Offices\District 3\Projects\D346568\CADData\D346568-PLANS.dgn	DRAWN - EM	REVISED -		VARIOUS	D3 HT PVMNT MRK RPR 22-19	VARIOUS	15	14			
Default	PLOT SCALE = 100,0000' / in.	CHECKED - RWV	REVISED -		SCALE: SHEET 7 OF 8 SHEETS STA. TO STA.			CONTRACT NO. 46583				
	PLOT DATE = 4/16/2021	DATE - 7/2/19	REVISED -		ILLINOIS FED. AID PROJECT							

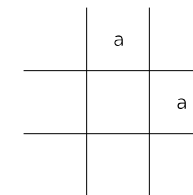
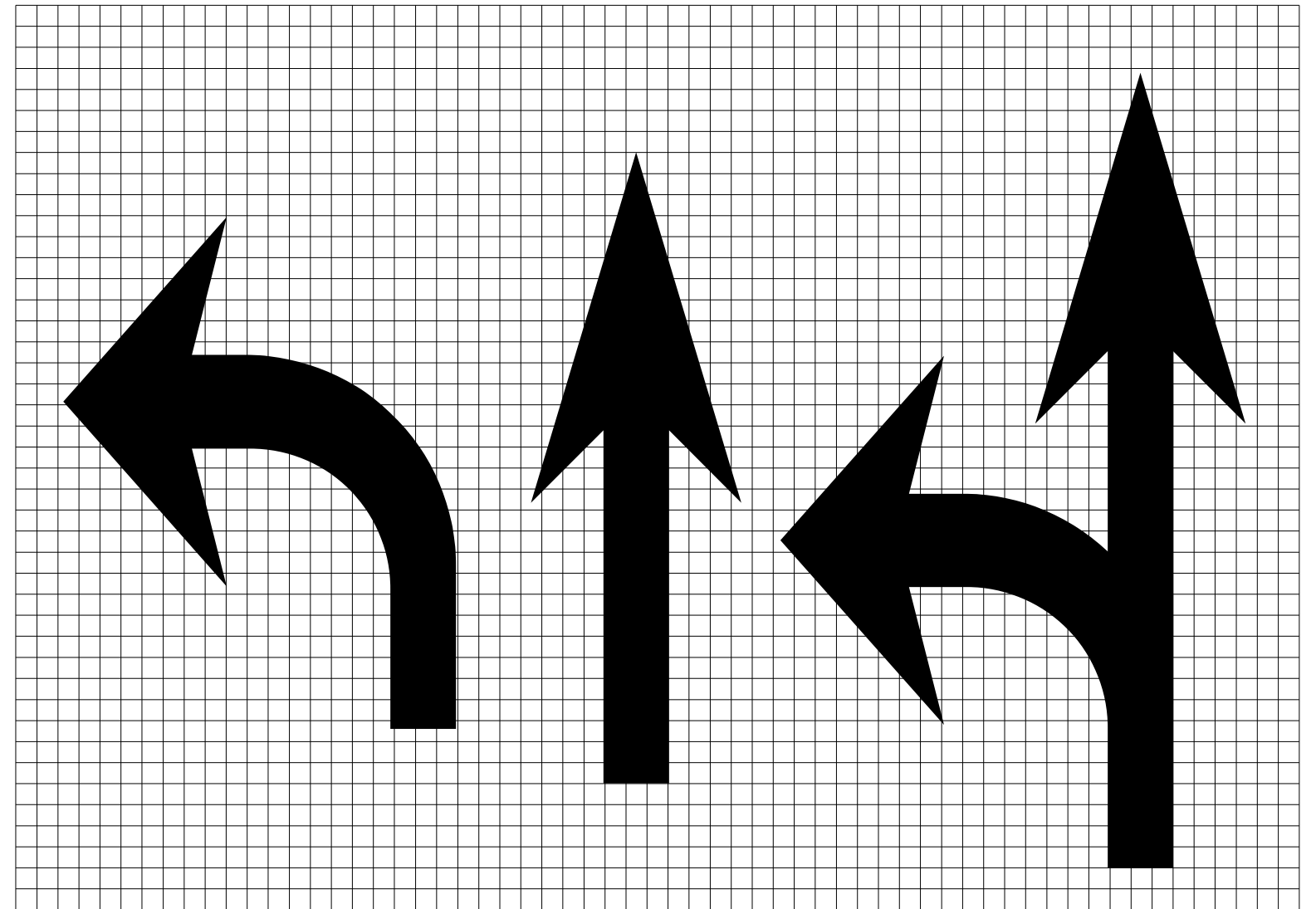

Legend Height	Arrow Size	a
6' (1.8 m)	Small	2.9 (74)
8' (2.4 m)	Large	3.8 (96)

The space between adjacent letters or numerals should be approximately 3 (75) for 6' (1.8 m) legend and 4 (100) for 8' (2.4 m) legend.

LETTER AND ARROW GRID SCALE

FILE NAME =	USER NAME = woodshank1	DESIGNED - EM	REVISED -
pw:\planroom\dot\illinois\gov\PWDOT\Documents\IDOT\offices\District 3\Projects\D346568\CADData\D346568-PLANS.dgn		DRAWN - EM	REVISED -
Default	PLOT SCALE = 100,0000 / in.	CHECKED - RW	REVISED -
	PLOT DATE = 4/16/2021	DATE - 7/2/19	REVISED -

**STATE OF ILLINOIS
DEPARTMENT OF TRANSPORTATION**

PAVEMENT MARKING DETAILS

SCALE: SHEET 8 OF 8 SHEETS STA. TO STA.

ROUTE	SECTION	COUNTY	TOTAL SHEETS	SHEET NO.
VARIOUS	D3 HT PVMNT MRK RPR 22-19	VARIOUS	15	15
			CONTRACT NO. 46583	
ILLINOIS FED. AID PROJECT				