**STRUCTURE GEOTECHNICAL REPORT
EAST AVENUE RETAINING WALL
PR SN 016-Z022
COOK COUNTY, ILLINOIS**

**For
Accurate Group, Inc.
101 Schelter Road, Suite B200
Lincolnshire, IL 60069**

**Submitted by
Wang Engineering, Inc.
1145 North Main Street
Lombard, IL 60148**

**Original Report: January 25, 2018
Revised Report: October 29, 2018**

Technical Report Documentation Page

1. Title and Subtitle Structure Geotechnical Report, East Avenue Retaining Wall		2. Original Date: January 25, 2018 Revised Date: October 29, 2018
		3. Report Type <input checked="" type="checkbox"/> SGR <input type="checkbox"/> RGR <input type="checkbox"/> Draft <input checked="" type="checkbox"/> Final <input checked="" type="checkbox"/> Revised
4. Route / Section / County/ District/ Region FAU 2719/ 0102N&T/ Cook/ 1/ 1		5. Contract NA
6. PTB / Item No. 180/002	7. Existing Structure Number(s) NA	8. Proposed Structure Number(s) SN 016-Z022
9. Prepared by Wang Engineering, Inc. 1145 N Main Street Lombard, IL 60148	Contributor(s) Author: Andri A Kurnia, PE Nesam S Balakumaran, P.Eng QA/QC: Corina T Farez, PE, PG PM: Liviu Iordache, PG	Contact (630) 953-9928 ext. 1025 akurnia@wangeng.com
10. Prepared for Accurate Group, Inc. 101 Schelster Road Suite B200 Lincolnshire, IL, 60069	Design Engineer Jennifer Tobergte, PE Sapan Trivedi	Contact (847) 613-1100 jent@accgi.com
11. Abstract <p>To facilitate the widening of East Avenue, a new retaining wall will be constructed just east of the northbound lane from about 1200 feet north of Joliet Road to 55th Street. The proposed 1603.5-foot long drilled soldier pile and lagging wall will have a maximum retained height of 7.5 feet and a maximum total height of 9.5 feet. This report provides geotechnical recommendations for the design and construction of the proposed retaining wall.</p> <p>Beneath pavement and up to 7 feet of fill material, the general lithologic profile includes 5 to 13 feet of very stiff to hard clay and silty clay diamicton with occasional granular lenses followed by dense to very dense gravelly sand to sandy gravel with highly fractured weathered dolostone fragments. Strong, very poor to fair quality dolostone was encountered at about 10 to 25 feet below existing grade or at elevations of 625 to 636 feet. The groundwater level was observed in one boring at elevation of 641 feet. Although the groundwater was not encountered during subsurface investigation in most of soil borings, the design and construction of the wall should consider perched groundwater elevations between 643 and 647 feet in granular fill layers. In addition, the design and construction should also consider the sand and gravel lenses as water-bearing layers.</p> <p>We understand a drilled soldier pile and treated timber lagging wall is the preferred wall type. The soil parameters are included in report. Global stability analyses indicate the wall will have satisfactory factors of safety greater than 1.7. We estimate the foundation soils will undergo settlement of 1 inch or less.</p> <p>Other wall types such as reinforced concrete cantilever (RCC) and mechanically-stabilized earth (MSE) walls could also be considered. However, temporary soil retention will be required. Following the soil treatment, we estimate the foundation soil will have a maximum factored bearing resistance of 8,200 psf for RCC wall and 9,700 psf for MSE wall.</p>		
12. Path to archived file S:\Netprojects\4910301\Reports\SGR_RetWall\RPT_Wang_AAK_4910301EastAveRWSGR_V2_20181029.docpdf		

TABLE OF CONTENTS

1.0	INTRODUCTION	1
1.1	PROPOSED STRUCTURE	1
1.2	EXISTING STRUCTURE AND LAND USE	1
2.0	GEOLOGICAL SETTING	2
2.1	PHYSIOGRAPHY	2
2.2	SURFICIAL COVER	2
2.3	BEDROCK.....	3
3.0	METHODS OF INVESTIGATION	3
3.1	FIELD INVESTIGATION.....	3
3.2	LABORATORY TESTING.....	4
4.0	INVESTIGATION RESULTS	4
4.1	LITHOLOGICAL PROFILE.....	4
4.2	GROUNDWATER CONDITIONS.....	7
5.0	ANALYSIS AND RECOMMENDATIONS	7
5.1	SEISMIC DESIGN CONSIDERATIONS	8
5.2	DRILLED SOLDIER PILE AND TREATED TIMBER LAGGING WALL.....	8
5.3	REINFORCED CONCRETE CANTILEVER WALL	12
5.4	MECHANICALLY STABILIZED EARTH WALL	13
5.5	SETTLEMENT ANALYSES.....	14
5.6	GLOBAL STABILITY ANALYSES.....	14
6.0	CONSTRUCTION CONSIDERATIONS	14
6.1	SITE PREPARATION	14
6.2	EXCAVATION, DEWATERING AND UTILITIES.....	14
6.3	FILLING AND BACKFILLING.....	15
6.4	DRILLED SOLDIER PILE CONSTRUCTION.....	15
6.5	WALL CONSTRUCTION.....	15
7.0	QUALIFICATIONS.....	16
	REFERENCES	17

EXHIBITS

- 1. *SITE LOCATION MAP*
- 2. *SITE AND REGIONAL GEOLOGY*
- 3. *BORING LOCATION PLAN*
- 4. *SOIL PROFILE*

APPENDIX A

- BORING LOGS*

APPENDIX B

- LABORATORY TEST RESULTS*

APPENDIX C

- GLOBAL STABILITY ANALYSIS*

APPENDIX D

- BEDROCK CORE PHOTOGRAPHS*

APPENDIX E

- TSL DRAWINGS*

LIST OF TABLES

Table 1: Top of Weathered and Sound Bedrock Elevations and Rock Quality Designations.....	6
Table 2: Geotechnical Parameters for Design of S-P Wall between Sta. 217+64 and 226+50	8
Table 3: Geotechnical Parameters for Design of S-P Wall between Sta. 226+50 and 230+20	9
Table 4: Geotechnical Parameters for Design of S-P Wall between Sta. 230+20 and 233+49.5	10
Table 5: Recommended Parameters for Lateral Load Analysis of S-P Wall between Sta. 217+64 and 226+50	10
Table 6: Recommended Parameters for Lateral Load Analysis of S-P Wall between Sta. 226+50 and 230+20	11
Table 7: Recommended Parameters for Lateral Load Analysis of S-P Wall between Sta. 230+20 and 233+49.5	11
Table 8: Recommended Bedrock Parameters for Lateral Load Analysis.....	12
Table 9: Foundation Soil Treatment Recommendations for RCC Wall.....	13

**STRUCTURE GEOTECHNICAL REPORT
EAST AVENUE RETAINING WALL
PR SN 016-Z022
COOK COUNTY, ILLINOIS
FOR
ACCURATE GROUP, INC.**

1.0 INTRODUCTION

This report presents the results of our subsurface investigation, laboratory testing, geotechnical evaluations, and recommendations to support the design and construction of the proposed Retaining Wall (SN 016-Z022) at the east side of the East Avenue northbound lane. The proposed structure is part of the proposed improvements along East Avenue from Joliet Road to 55th Street in Cook County, Illinois. A *Site Location Map* is presented as Exhibit 1.

1.1 Proposed Structure

Based on the final Type, Size, and Location sheets (TSL) provided by Accurate Group, Inc. (Accurate) on October 27, 2018, Wang Engineering, Inc. (Wang) understands the proposed 1603.5-foot long retaining wall will be constructed to support the roadway. The wall begins at Station 217+64 runs along east side of East Avenue to a kink point at Station 233+07.60. Then the wall takes a turn along the curb at the East Avenue and 55th Street intersection and ends at Station 233+49.50 (East Avenue stationing) at 55th Street south side. The wall is proposed to be a drilled soldier pile and treated timber lagging wall with a maximum retained height of 7.5 feet and a maximum total height of 9.5 feet.

1.2 Existing Structure and Land Use

There is no existing retaining wall at the site. There is a trapezoidal shape ditch which runs approximately parallel to the proposed wall on the east side. The surrounding land includes a quarry on the east side and commercial/residential properties on the west side of East Avenue.

The purpose of this investigation was to characterize the site soil and groundwater conditions, perform geotechnical analyses, and provide recommendations for the design and construction of the proposed retaining wall.

2.0 GEOLOGICAL SETTING

The project area is located in western Cook County, in Lyons Township. On the USGS *Berwyn Quadrangle 7.5 Minute Series* map, the retaining wall extends within NW $\frac{1}{4}$ of Section 15 at the limit with Section 16, Tier 38 N, Range 12 E of the Third Principal Meridian.

The following review of published geologic data, with emphasis on factors that might influence the design and construction of the proposed engineering works, is meant to place the project area within a geological framework and, thus, to confirm the dependability and consistency of the subsurface investigation results. For the study of the regional geologic framework, Wang considered northeastern Illinois area in general and Cook County in particular.

2.1 Physiography

Cook County is dominated by Chicago Lake Plain and Wheaton Morainal Country physiographic sections (Leighton et al. 1948). The project site is situated at the limit between the two physiographic sections, within the east limit of Wheaton Morainal Country. The relief within the project area is generally flat. Along the wall alignment, the existing surface elevation increases northward from 645 and 650 feet. There is a Vulcan Quarry located east of the wall with bottom of excavation up to 300 feet below the ground surface (bgs).

2.2 Surficial Cover

The surficial cover is 10 to 20-foot thick as a result of Wisconsin-age glacial activity (Leetaru et al. 2004). The glacial deposits were emplaced during pulsating advances and retreats of an icesheet lobe responsible for the formation of end moraines and associated low-relief till and lake plains lacustrine deposit (Johnson and Hansel 1999). The Tinley groundmoraine dominates the surficial cover within the project area and consists predominantly of clayey diamicton of the Wadsworth Formation. The Wadsworth Formation is identified as relatively homogeneous, gray till with clay to silty clay matrix, a high content of dolomite and shale clasts and occasional lenses of sorted and stratified silt and sand (Hansel and Johnson 1996). The diamicton rests directly over sand and gravel or directly over the bedrock in various degrees of weathering. The *Site and Regional Geology* is illustrated in Exhibit 2.

From a geotechnical viewpoint, the Wadsworth Formation diamicton is characterised by moderate to low plasticity, medium to low moisture content, medium to hard consistency, poor permeability, and low compressibility (Bauer et al. 1991).

2.3 Bedrock

In central Cook County, the surficial cover rests unconformably on top of Silurian-age bedrock that dips eastward at a pace of about 15 feet per mile. The top of the bedrock lies 10 to 20 feet bgs. Being so shallow, the bedrock within the project area is moderately to highly weathered. Structurally, the site is located on the eastern flank of the Wisconsin Arch (Willman 1971). No active faults or underground mines are known in the area. Vulcan Quarry open excavation borders the wall on its east side.

Our subsurface investigation results fit into the local geologic context. The borings drilled in the project area encountered native sediments consisting of occasional patches of clayey, lacustrine deposits overlying silty clay diamicton with gravel and sand lenses. The borings encountered dolostone bedrock at elevations of 636 to 626 feet, or about 10 to 25 feet bgs.

3.0 METHODS OF INVESTIGATION

The following sections outline the subsurface and laboratory investigations performed by Wang.

3.1 Field Investigation

The subsurface investigation consisted of 22 structure borings, designated as RWB-01 through RWB-22. The borings were drilled by Wang between June and August 2017. The borings were drilled from elevations of 644.5 to 650.9 feet and were advanced to depths of 10.0 to 29.0 feet bgs. The as-drilled northing and easting coordinates were acquired with a mapping-grade GPS unit. Elevations, stations, and offsets were provided by Accurate. Four historical borings, designated as RW-01 through RW-04, drilled by Wang in 2012 along north end of the wall were included in this report. Boring location data are presented in the *Boring Logs* (Appendix A) and the as-drilled boring locations are shown in the *Boring Location Plan* (Exhibit 3).

Truck- and ATV-mounted drilling rigs, equipped with hollow stem augers, were used to advance and maintain open boreholes. Soil sampling was performed according to AASHTO T206, "*Penetration Test and Split Barrel Sampling of Soils.*" The soil was sampled at 2.5-foot intervals to the boring

termination depth or the top of sound bedrock. Bedrock cores were obtained in eight current investigation borings and in one historical boring in 5 to 10-foot runs with an NWD4-sized core barrel. Soil samples collected from each sampling interval were placed in sealed jars and transported to the laboratory for further examination and laboratory testing.

Field boring logs, prepared and maintained by Wang geologists, include lithological descriptions, visual-manual soil (IDH Textural) classifications, results of Rimac and pocket penetrometer unconfined compressive strength tests, and results of Standard Penetration Tests (SPT) recorded as blows per 6 inches of penetration. The bedrock cores were described and measured for recovery and Rock Quality Designation (RQD).

Groundwater levels were measured while drilling and at completion of each boring. For safety considerations each boreholes was backfilled upon completion with soil cuttings and/or bentonite chips and, where necessary, the pavement surface was restored to its original condition.

3.2 Laboratory Testing

The soil samples were tested in the laboratory for moisture content (AASHTO T265). Atterberg limits (AASHTO T89 and T90) and particle size (AASHTO T88) analyses were performed on selected samples. Field visual descriptions of the soil samples were verified in the laboratory. Uniaxial compressive strength tests were performed on selected bedrock cores. Laboratory test results are shown in the *Boring Logs* (Appendix A) and in the *Laboratory Test Results* (Appendix B).

4.0 INVESTIGATION RESULTS

Detailed descriptions of the soil conditions encountered during the subsurface investigation are presented in the attached *Boring Logs* (Appendix A) and in the *Soil Profile* (Exhibit 4). Please note that strata contact lines represent approximate boundaries between soil types. The actual transition between soil types in the field may be gradual in horizontal and vertical directions.

4.1 Lithological Profile

The borings were drilled through the East Avenue northbound lane and encountered 7- to 16- inch thick asphalt pavement over 3 to 25 inches of aggregate base or directly over the cohesive fill. In descending order, the general lithologic succession encountered beneath the pavement includes:

1) man-made ground (fill); 2) very stiff to hard silty clay diamicton; 3) dense to very dense gravelly sand; and 4) strong, very poor quality dolostone.

1) Man-made ground (fill)

Beneath the surface, borings encountered 0.3 to 7.3 feet of cohesive and granular fill. The cohesive fill consists of stiff to hard brown to brown and gray silty clay diamicton with unconfined compressive strength (Q_u) values of 1.0 to 5.2 tsf with an average of 2.5 tsf and moisture content values of 6% to 26% with an average of 19%. The granular fill consists of up to 2.1 feet of loose to medium dense, brown gravelly loam and gravelly sand with SPT N-values of 8 to 11 blows per foot. Up to 1.6-foot thick buried topsoil with moisture content values of 14 to 30% was sampled beneath the fill in Borings RWB-15 and RWB-17.

2) Stiff to hard silty clay diamicton

Beneath the fill and topsoil, at elevations of 639 to 646 feet, the borings encountered 5 to 13 feet of stiff to hard, brown and gray clay to silty clay diamicton with occasional granular lenses. The diamicton is characterized by Q_u values of 1.6 to 8.0 tsf with an average of 4.2 tsf and moisture content values of 14 to 25% with an average of 21%. Laboratory index testing on a sample from the silty clay loam layer showed liquid limit (L_L) values of 39 to 43% and plastic limit (P_L) values of 21%. This layer has an average liquidity index (L_I) of about 0.1, indicating overconsolidated soils that are not prone to long-term settlement.

3) Dense to very dense gravelly sand

Below the diamicton, the borings encountered dense to very dense, gray gravelly sand to sandy gravel with highly weathered dolostone fragments continuing to the top of bedrock. More likely is highly to moderately weathered bedrock. This unit has N-value of more than 30 blows per foot to sampler refusal, and moisture content values of 3 to 8% with an average of 5%. Hard drilling conditions characterize this unit.

4) Strong, very poor quality dolostone

A total of eight soil borings were cored through dolostone bedrock beginning at 10.0 to 18.5 feet bgs or at elevations of 630 to 636 feet. We encountered auger refusal at 10 to 25 feet bgs, or at elevations of 625 to 636 feet on other soil borings. The rock is horizontally thinly bedded, highly vuggy, moderately weathered, and moderately to highly fragmented. The joints walls are rough and hard, the joints spacing averages 1.5 inches, and the joints infill and shale partings are highly weathered.

The rock mass quality is very poor with rock quality designation (RQD) values ranging from 0 to 12%. The compressive strength tests showed Q_u values of 5.5 to 6.0 ksi. One historical soil Boring, Boring RW-02, was cored through dolostone bedrock at 24.0 feet bgs or at an elevation of 626 feet with an RQD of 64%. Bedrock core description is shown in the boring logs (Appendix A) and rock core photographs are attached in Appendix D. A summary of top of weathered bedrock and strong bedrock elevations as well as RQD values recorded in the borings are presented in Table 1.

Table 1: Top of Weathered and Sound Bedrock Elevations and Rock Quality Designations

Boring ID	Top of Weathered Bedrock Elevation (feet)	Top of Sound Bedrock Elevation (feet)	Rock Quality Designation of Sound Bedrock (%)
RWB-01	634.0	632.5	0
RWB-02	635.1	634.6	--
RWB-03	636.3	635.0	0
RWB-04	635.7	635.2	--
RWB-05	634.9	633.4	0
RWB-06	635.6	635.1	--
RWB-07	634.9	633.9	0
RWB-08	635.6	635.1	--
RWB-09	637.6	636.4	0
RWB-10	636.7	635.7	--
RWB-11	635.3	634.6	0
RWB-12	635.1	634.4	--
RWB-13	633.0	630.7	0
RWB-14	631.0	NA	--
RWB-15	627.4	NA	--
RWB-16	628.7	NA	--
RWB-17	630.6	630.1	12
RWB-18	631.5	626.5	--
RWB-19	629.4	625.4	--
RW-01	631.4	NA	--
RWB-20	627.2	NA	--

Boring ID	Top of Weathered Bedrock Elevation (feet)	Top of Sound Bedrock Elevation (feet)	Rock Quality Designation of Sound Bedrock (%)
RW-02	632.5	625.8	64
RWB-21	630.1	628.4	--
RWB-22	NA	NA	--
RW-03	632.1	NA	--
RW-04	632.3	NA	--

4.2 Groundwater Conditions

Groundwater was not encountered in any of the boreholes. However various degrees of moisture are mentioned in the boring logs (Appendix A). The sand and gravel lenses within the diamicton are damp to wet. Historical boring, RW-04, encountered the groundwater at an elevation of 641 feet in the sand layer. We estimate the groundwater is situated below the investigated depth.

Although the groundwater was not encountered during subsurface investigation in most of soil borings, the design and construction of the wall should consider perched groundwater elevations between 643 and 647 feet in granular fill layers. In addition, the design and construction should also consider the sand and gravel lenses as potential water-bearing layers.

5.0 ANALYSIS AND RECOMMENDATIONS

Based on the TSL sheets (Appendix E), the 1603.5-foot long retaining wall is proposed to support the East Avenue roadway along the east side. The proposed wall will have maximum retained height of 7.5 feet and a maximum total height of 9.5 feet. There is a trapezoidal shape ditch which runs approximately parallel to the proposed wall on the east side.

We understand a drilled soldier pile and treated timber lagging wall is the preferred wall type, as the drilled soldier piles can be cored through the shallow bedrock and minimize noise and vibration. As alternatives, the wall could also be constructed as reinforced concrete cantilever (RCC) and mechanically-stabilized earth (MSE). However, these walls will require temporary soil retention system or an open cut excavation along the roadway, additional construction time, and possible detour

of East Avenue. Due to the shallow bedrock encountered along retaining wall, driven soldier piles or sheet piling may not be feasible. The final wall type should be selected based on a wall-type study including cost and construction considerations. The following sections address drilled soldier pile, RCC, and MSE walls.

5.1 Seismic Design Considerations

Seismic design is not required for retaining wall structures located in Seismic Performance Zone (SPZ) 1 in accordance with the IDOT *Bridge Manual* (2012).

5.2 Drilled Soldier Pile and Treated Timber Lagging Wall

The drilled soldier piles should be designed for both moment equilibrium in lateral earth pressure and lateral deformation. The embedment depth in moment equilibrium for the wall sections should be designed in accordance with the 2017 LRFD AASHTO guidelines (AASHTO 2017) which will require an active earth pressure factor of 1.5 and a passive lateral earth pressure resistance factor of 0.75. The geotechnical parameters for the earth pressure analysis are presented in Tables 2 through 4 based on the station limits and boring locations. The resistance factor for drilled soldier pile wall should be in accordance with 2017 AASHTO LRFD Specifications. Based on the cross-section drawings, the wall will have a horizontal back slope and 1:2.5 (V:H) front slope.

The design of the wall should ignore 3 feet of soil in front of the wall measured from the finished ground surface elevation in providing passive pressure due to excavation required for installation of concrete facing, drainage system and frost-heave condition. In developing the design lateral pressure, the lateral pressure due to construction equipment surcharge load should be added to the lateral earth pressure. Drainage behind the wall and underdrain should be as per 2012 IDOT *Bridge Manual* (IDOT 2012). The water pressure should be added to the earth pressure if drainage is not provided.

Table 2: Geotechnical Parameters for Design of S-P Wall between Sta. 217+64 and 226+50
 (Reference Borings: RWB-01 through RWB-12)

Soil Description (Layer)	Unit Weight, γ (pcf)	Drained Shear Strength Properties		Earth Pressure Coefficients	
		Cohesion (psf)	Friction Angle ($^{\circ}$)	Active Pressure	Passive Pressure
Stiff SILTY CLAY FILL Finished grade to EL 642 feet	120	100	30	0.33	--

Soil Description (Layer)	Unit Weight, γ (pcf)	Drained Shear Strength Properties		Earth Pressure Coefficients	
		Cohesion (psf)	Friction Angle ($^{\circ}$)	Active Pressure	Passive Pressure
M Dense GRANULAR FILL Finished grade to EL 642 feet	120	0	30	0.33	--
V Stiff to Hard SILTY CLAY EL 642 to 638 feet	125	100	30	0.33	1.44 (1:2.5)
V Stiff to Hard SILTY CLAY EL 638 to 636 feet	125	100	30	0.33	3.00
V Dense WEATHERED BEDROCK EL 636 to 634 feet	130	0	37	0.25	4.02

Table 3: Geotechnical Parameters for Design of S-P Wall between Sta. 226+50 and 230+20
 (Reference Borings: RWB-13 through RWB-17)

Soil Description (Layer)	Unit Weight, γ (pcf)	Drained Shear Strength Properties		Earth Pressure Coefficients	
		Cohesion (psf)	Friction Angle ($^{\circ}$)	Active Pressure	Passive Pressure
Stiff CLAY LOAM FILL Finished grade to EL 645 feet	120	100	30	0.33	--
M Dense GRANULAR FILL Finished grade to EL 645 feet	120	0	30	0.33	--
V Stiff to Hard SILTY CLAY EL 645 to 638 feet	125	100	30	0.33	1.44 (1:2.5)
V Stiff to Hard SILTY CLAY EL 638 to 634 feet	125	100	30	0.33	3.00
Dense to V Dense GRAVELLY SAND to SANDY GRAVEL EL 634 to 629 feet	130	0	35	0.27	3.69
V Dense WEATHERED BEDROCK EL 629 to 626 feet	130	0	37	0.25	4.02

Table 4: Geotechnical Parameters for Design of S-P Wall between Sta. 230+20 and 233+49.5
 (Reference Borings: RWB-17 through RWB-22)

Soil Description (Layer)	Unit Weight, γ (pcf)	Drained Shear Strength Properties		Earth Pressure Coefficients	
		Cohesion (psf)	Friction Angle ($^{\circ}$)	Active Pressure	Passive Pressure
Stiff SILTY CLAY to CLAY LOAM FILL Finished grade to EL 644 feet	120	100	30	0.33	--
V Stiff to Hard SILTY CLAY EL 644 to 638 feet	125	100	30	0.33	1.44 (1:2.5)
V Stiff to Hard SILTY CLAY EL 638 to 636 feet	125	100	30	0.33	3.00
V Stiff CLAY to SILTY CLAY EL 636 to 632 feet	125	100	30	0.33	3.00
Dense to V Dense GRAVELLY SAND to SANDY GRAVEL EL 632 to 627 feet	130	0	35	0.27	3.69
V Dense WEATHERED BEDROCK Below EL 627 feet	130	0	37	0.25	4.02

The lateral deformation of the wall should be designed for deformation and moment fixity at the pile tip. The roadway, sidewalk, and utilities should not be impacted by the lateral movement of wall. Therefore, the design of soldier pile wall should establish the lateral movement limits. The evaluation should be performed using the soil parameters shown in Tables 5 through 7 based on station limits and boring locations and rock parameters in Table 8 using the p-y curve (COM624) method.

Table 5: Recommended Parameters for Lateral Load Analysis of S-P Wall between Sta. 217+64 and 226+50
 (Reference Borings: RWB-01 through RWB-12)

Soil Type (Layer)	Unit Weight γ (pcf)	Undrained Shear Strength, c_u (psf)	Estimated Friction Angle, Φ ($^{\circ}$)	Estimated Lateral Soil Modulus Parameter, k (pci)	Estimated Soil Strain Parameter, ϵ_{50} (%)
Stiff SILTY CLAY FILL Finished grade to EL 642 feet	120	1500	0	500	0.7
M Dense GRANULAR FILL Finished grade to EL 642 feet	120	0	30	60	--

Soil Type (Layer)	Unit Weight γ (pcf)	Undrained Shear Strength, c_u (psf)	Estimated Friction Angle, Φ ($^\circ$)	Estimated Lateral Soil Modulus Parameter, k (pci)	Estimated Soil Strain Parameter, ϵ_{50} (%)
V Stiff to Hard SILTY CLAY EL 642 to 638 feet	125	4000	0	2000	0.4
V Stiff to Hard SILTY CLAY EL 638 to 636 feet	125	5000	0	2000	0.4
V Dense WEATHERED BEDROCK EL 636 to 634 feet	130	0	36	125	--

Table 6: Recommended Parameters for Lateral Load Analysis of S-P Wall between Sta. 226+50 and 230+20
 (Reference Borings: RWB-13 through RWB-17)

Soil Type (Layer)	Unit Weight γ (pcf)	Undrained Shear Strength, c_u (psf)	Estimated Friction Angle, Φ ($^\circ$)	Estimated Lateral Soil Modulus Parameter, k (pci)	Estimated Soil Strain Parameter, ϵ_{50} (%)
Stiff CLAY LOAM FILL Finished grade to EL 645 feet	120	1200	0	500	0.7
M Dense GRANULAR FILL Finished grade to EL 645 feet	120	0	30	60	--
V Stiff to Hard SILTY CLAY EL 645 to 638 feet	125	3000	0	1000	0.5
V Stiff to Hard SILTY CLAY EL 638 to 634 feet	125	4100	0	2000	0.4
Dense to V Dense GRAVELLY SAND to SANDY GRAVEL EL 634 to 629 feet	130	0	35	125	--
V Dense WEATHERED BEDROCK EL 629 to 626 feet	130	0	37	125	--

Table 7: Recommended Parameters for Lateral Load Analysis of S-P Wall between Sta. 230+20 and 233+49.5
 (Reference Borings: RWB-18 through RWB-22)

Soil Type (Layer)	Unit Weight γ (pcf)	Undrained Shear Strength, c_u (psf)	Estimated Friction Angle, Φ ($^\circ$)	Estimated Lateral Soil Modulus Parameter, k (pci)	Estimated Soil Strain Parameter, ϵ_{50} (%)
Stiff SILTY CLAY to CLAY LOAM FILL Finished grade to EL 644 feet	120	1000	0	500	0.7

Soil Type (Layer)	Unit Weight γ (pcf)	Undrained Shear Strength, c_u (psf)	Estimated Friction Angle, Φ ($^\circ$)	Estimated Lateral Soil Modulus Parameter, k (pci)	Estimated Soil Strain Parameter, ϵ_{50} (%)
V Stiff to Hard SILTY CLAY EL 644 to 638 feet	125	4400	0	2000	0.4
V Stiff to Hard SILTY CLAY EL 638 to 636 feet	125	3500	0	1000	0.5
V Stiff CLAY to SILTY CLAY EL 636 to 632 feet	125	2500	0	1000	0.5
Dense to V Dense GRAVELLY SAND to SANDY GRAVEL EL 632 to 627 feet	130	0	35	125	--
V Dense WEATHERED BEDROCK EL 627 to 625 feet	130	0	37	125	--

Table 8: Recommended Bedrock Parameters for Lateral Load Analysis

Rock Type	Total Unit Weight, γ (pcf)	Modulus of Rock Mass (ksi)	Uniaxial Compressive Strength (ksi)	RQD (%)	Lateral Rock Modulus Parameter
Very Poor DOLOSTONE	135	280	5.5	0	0.0005

5.3 Reinforced Concrete Cantilever Wall

The RCC retaining wall base should be established at a minimum of 4.0 feet below the finished grade at the front face of the wall. For our analyses, we assume RCC wall foundation elevations will be between 636 and 637 feet. We estimate the RCC wall footing will be founded on either hard cohesive soils or very dense weathered bedrock; however, at the north end of the wall near 55th Street, Boring RWB-22 encountered soft clayey soils with Q_u value of 0.5 tsf and moisture content value of 21% beneath the footing elevation. We recommend removing this soil to an elevation of 634 feet and replacing with CA-6 or IDOT District One Special Provision “Aggregate Subgrade Improvement”. The limits of foundation soil treatment are summarized in Table 9.

Table 9: Foundation Soil Treatment Recommendations for RCC Wall

Station Limits	Proposed Treatment	Proposed		
	Lateral Extent ¹	Treatment Vertical Extent ² (Inches)	Replacement Material	Reference Boring, Conditions
233+07.60 to 233+49.50	Full Foundation Width	24	CA-6 or Aggregate Subgrade Improvement ³	RWB-22 ($Q_u = 0.98$ tsf, MC = 23%)

¹ The treatment should extend a minimum of 1-foot outside the foundation layout; ² Below footing elevation;

³ IDOT Distinct One Aggregate Subgrade Improvement

The actual lateral and vertical extents of soil treatment should be determined in the field using either static (SCP) or dynamic (DCP) cone penetrometer tests during construction.

Following the recommended treatment, the footing for the RCC wall can be designed for a nominal bearing resistance of 15,000 psf and factored bearing resistance of 8,200 psf based on a resistance factor of 0.55 (AASHTO 2017). The estimated friction angle between the base and the underlying silty clay is 22°, and the corresponding nominal friction coefficient is 0.40. The nominal coefficient of sliding can be taken as 0.50 if a one foot layer crushed stone (CA-7) is provided below the footing. Cast-in place concrete walls are designed based on a geotechnical sliding resistance factor of 1.0 (AASHTO 2017).

We recommend a linearly increasing unfactored lateral earth pressure of 40 psf per foot of depth below grade behind the wall with drainable backfill. We recommend providing Geocomposite Wall Drain as per IDOT Bridge Manual (2012).

5.4 Mechanically-Stabilized Earth Wall

An MSE retaining wall base should be established a minimum of 3.5 feet below the finished grade at the front face of the wall. We assumed the bottom of leveling pad elevations will be between 636 and 637 feet. The MSE wall will require the same treatment as described in RCC wall section.

Following the recommended treatment, the footing for the MSE wall can be designed for a nominal bearing resistance of 15,000 psf and factored bearing resistance of 9,700 psf based on a resistance

factor of 0.65 (AASHTO 2017). The wall will apply a maximum factored vertical pressure of 4,300 psf. The wall will have sufficient bearing resistance. The estimated friction angle between the base of the wall and the existing foundation soil is 30° and the corresponding friction coefficient is 0.58 (AASHTO 2017). MSE retaining walls are designed based on a geotechnical sliding resistance factor of 1.0 for soil-on-soil contact (AASHTO 2017). The eccentricity should be within the middle 2/3 of the wall. Resistance of wall against overturning and sliding is sufficient.

5.5 Settlement Analyses

Based on the cross-section drawings, the East Avenue roadway widening will require up to 2 feet of new fill. We estimate the foundation soils will undergo settlement of 1 inch or less which is acceptable.

5.6 Global Stability Analyses

The global stability of the proposed wall was analyzed based on the soil profile and the information provided in the cross-section drawings for the selected drilled soldier pile wall. The stability was analyzed at the critical section along East Avenue at Station 220+50 where the retained fill height is about 7 feet and the base of the wall is immediately west of the existing ditch. The minimum required factor of safety (FOS) for both short-term (undrained) and long-term (drained) conditions is 1.7 (IDOT 2015). *Slide v6.0* evaluation exhibits employing the Bishop Simplified method of analysis are shown in Appendix C. We estimate the soldier pile and treated timber lagging wall will have a FOS of 9.9 (Appendix C-1) in undrained conditions and 2.2 (Appendix C-2) in drained conditions. The FOS for each satisfies the minimum criteria of 1.7.

6.0 CONSTRUCTION CONSIDERATIONS

6.1 Site Preparation

Vegetation, surface topsoil, and debris should be cleared and stripped where the structure will be placed. If unstable or unsuitable materials are exposed during excavation, they should be removed and replaced with compacted fill as described in filling and backfilling section below.

6.2 Excavation, Dewatering, and Utilities

Excavations should be performed in accordance with local, state, and federal regulations. The potential effect of ground movements upon nearby utilities should be considered during construction. Excavations for the construction of the wall should be sloped at no steeper than 1:1.5 (V:H). For RCC

and MSE walls construction, an open cut excavation will not be feasible due to the close proximity of existing East Avenue traffic lane. Since the hard cohesive soils ($Q_u > 4.5$ tsf) encountered at embedment depths, temporary sheet piling using *IDOT Design Guide 3.13.1* may not be feasible. Therefore, the temporary soil retention will be required for RCC and MSE walls construction.

During the subsurface investigation, the groundwater was not encountered; however, the perched groundwater may be encountered between elevations 643 and 647 feet in granular fill layers. Although, the groundwater was not encountered during investigation, the groundwater may be encountered in granular layers during drilled soldier pile installation. Therefore, the contractor should be prepared to use temporary casing. Precipitation allowed to enter excavations should be immediately removed using sump pump. Any soils allowed to soften under standing water should be removed and replaced with compacted fill as described in filling and backfilling section below.

6.3 Filling and Backfilling

Fill material used to attain final design elevations should be pre-approved, compacted granular soil conforming to IDOT Section 205 Embankment (IDOT 2016). Backfill materials must be pre-approved by the Resident Engineer. The fill material should be free of organic matter and debris and should be placed in lifts and compacted in accordance with the IDOT Standard Specifications for Road and Bridge Construction (2016). To backfill the walls, we recommend porous granular material conforming to the requirements specified in the IDOT Recurring Special Provision, Granular Backfill for Structures (2017).

6.4 Drilled Soldier Pile Construction

Drilled soldier pile should be constructed in accordance with IDOT *Standard Specifications* Section 522, *Retaining Wall* (IDOT 2016).

6.5 Wall Construction

The walls should be constructed according to the current IDOT Standard Specifications for Road and Bridge Construction.

7.0 QUALIFICATIONS

The analysis and recommendations submitted in this report are based upon the data obtained from the borings drilled at the locations shown on the boring logs and in Exhibit 3. This report does not reflect any variations that may occur between the borings or elsewhere on the site, variations whose nature and extent may not become evident until the course of construction. In the event that any changes in the design and/or location of the structure are planned, we should be timely informed so that our recommendations can be adjusted accordingly. Wang is not responsible for any claims, damages, and liabilities arise from the interpretations by any other party of the subsurface data included in this report.

It has been a pleasure to assist Accurate Group, Inc. and the Illinois Department of Transportation on this project. Please call if there are any questions, or if we can be of further service.

Respectfully Submitted,

WANG ENGINEERING, INC.

Andri A. Kurnia
Andri A. Kurnia, P.E.
Senior Geotechnical Engineer

Corina T. Farez
Corina T. Farez, P.E., P.G.
QA/QC Reviewer

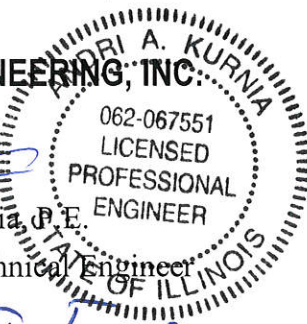

Nesam S. Balakumaran
Nesam S Balakumaran, P.Eng.
Project Geotechnical Engineer

REFERENCES

- AMERICAN ASSOCIATION OF STATE HIGHWAY TRANSPORTATION OFFICIALS (2017) "AASHTO LRFD Bridge Design Specifications." United States Department of Transportation, Washington, D.C.
- BAUER, R.A., CURRY, B.B., GRAESE, A.M., VAIDEN, R.C., SU, W.J., and HASEK, M.J. (1991) "Geotechnical Properties of Selected Pleistocene, Silurian, and Ordovician Deposits of Northeastern Illinois." *Environmental Geology 139*, Illinois State Geological Survey.
- IDOT (2012) *Bridge Manual*. Illinois Department of Transportation.
- IDOT (2015) *Geotechnical Manual*. Illinois Department of Transportation.
- IDOT (2016) *Standard Specifications for Road and Bridge Construction*. Illinois Department of Transportation. 1098 pp.
- JOHNSON, W.H., and HANSEL, A.K. (1999) "Wisconsin Episode glacial landscape of central Illinois: A product of subglacial deformation process." *Geological Society of America Special Paper 337*, p. 121-135.
- LEETARU, H.E., SARGENT, M.L., AND KOLATA, D.R (2004) *Geologic Atlas of Cook County for Planning Purposes*. ISGS, Champaign, IL
- LEIGHTON, M.M., EKBLAW, G.E., and HORBERG, L. (1948) "Physiographic Divisions of Illinois." *The Journal of Geology*, v. 56. p. 16-33.
- WILLMAN, H.B. (1971) "Summary of the Geology of the Chicago Area." *ISGS Circular C460*. Illinois State Geological Survey, p. 77.

EXHIBITS

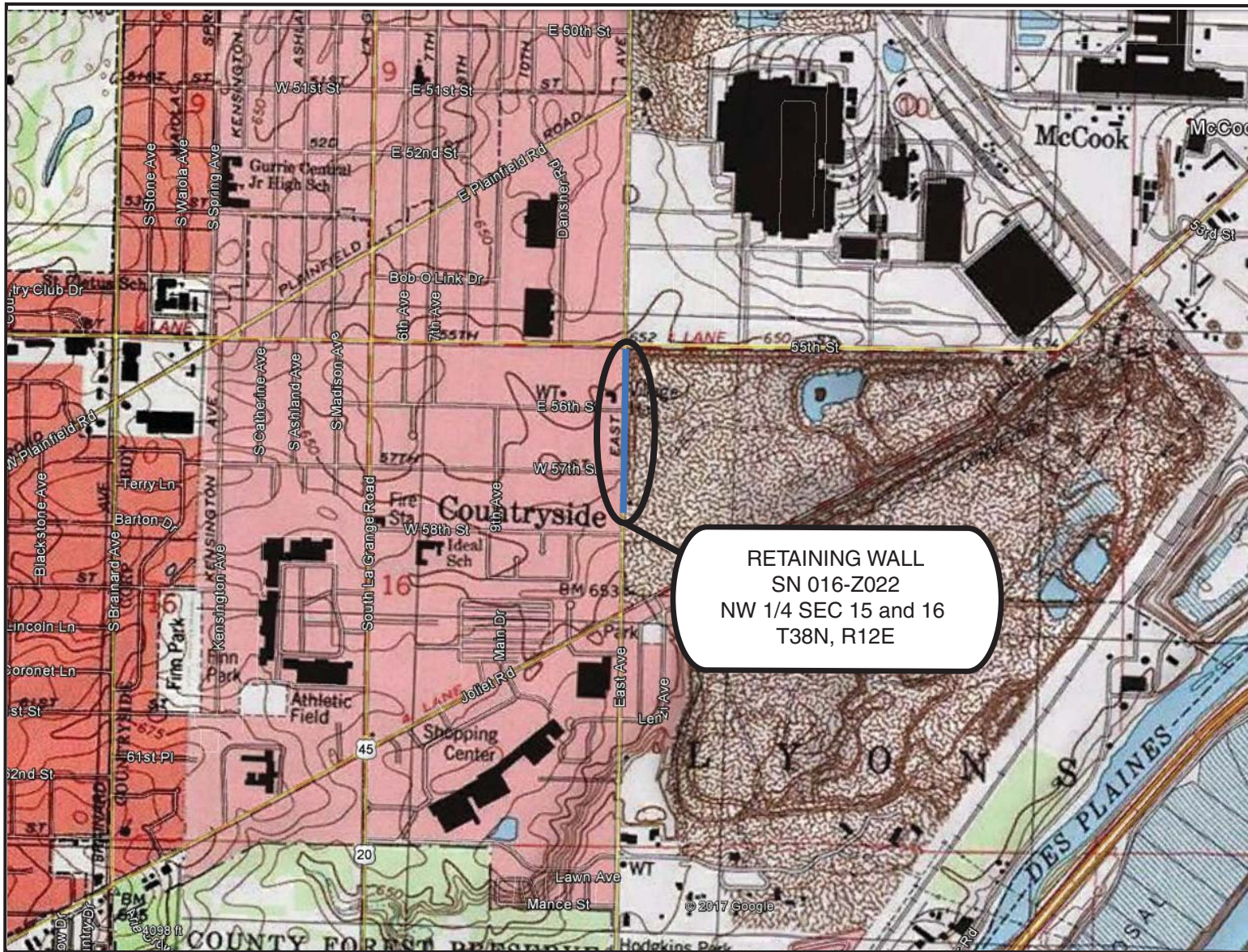

RETAINING WALL
 SN 016-Z022
 NW 1/4 SEC 15 and 16
 T38N, R12E

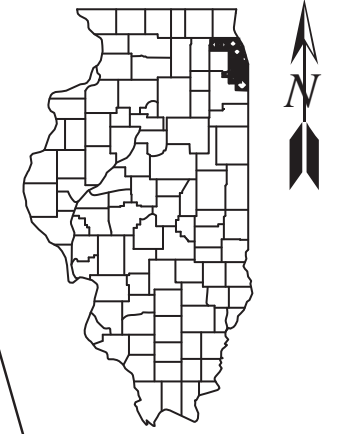

Cook County

Scale

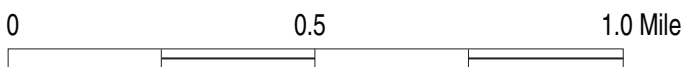

SITE LOCATION MAP: EAST AVENUE FROM JOLIET ROAD TO 55TH STREET, RETAINING WALL, SN 016-Z022, COOK COUNTY

SCALE: GRAPHICAL	EXHIBIT 1	DRAWN BY: H. Bista CHECKED BY: A. Kurnia
------------------	------------------	---

	1145 N. Main Street Lombard, IL 60148 www.wangeng.com
	FOR ACCURATE GROUP, INC.

491-03-01

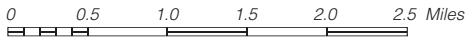
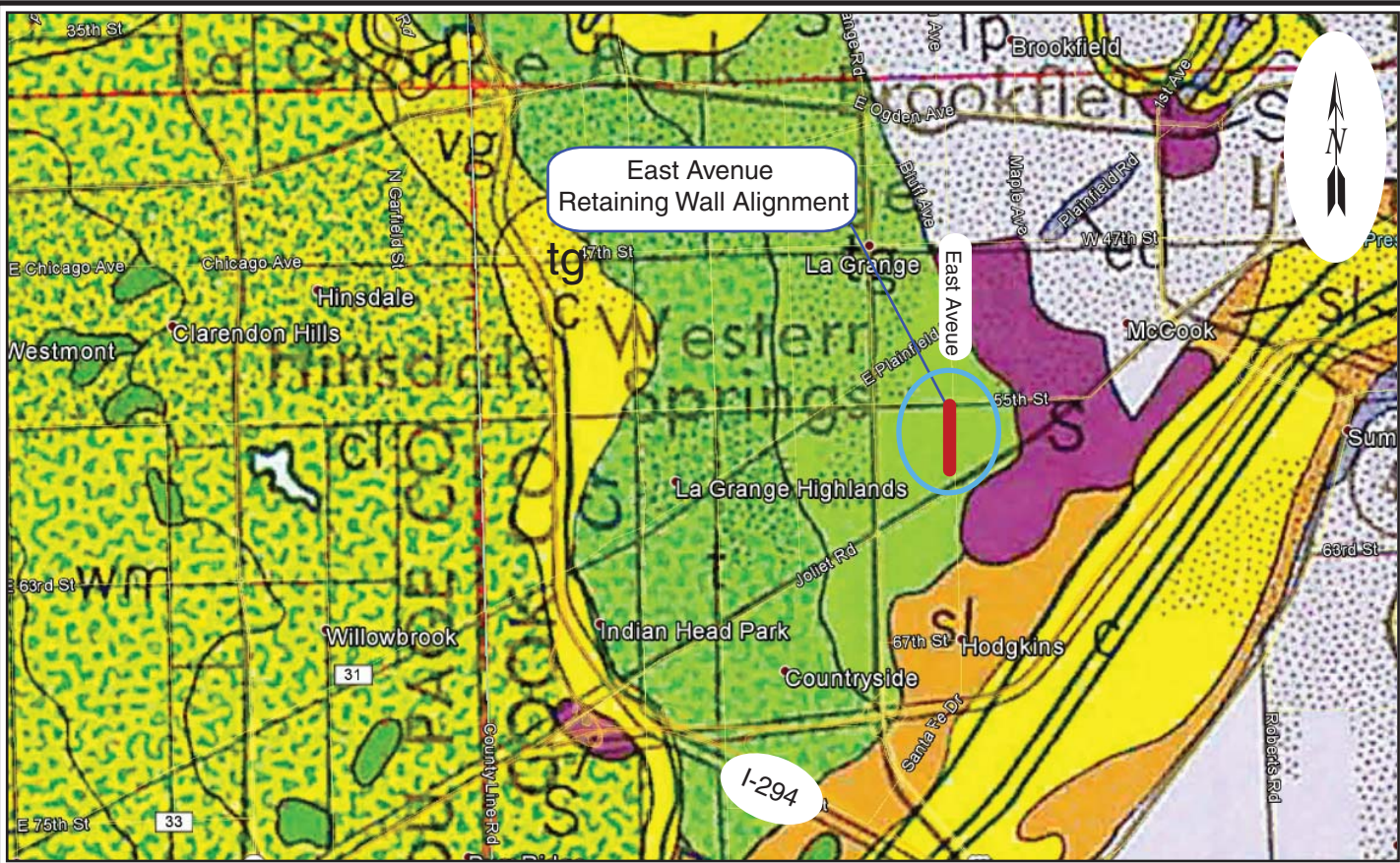

Modified after Willman(1971)

LEGEND

- Densely built-up residential and commercial areas
- c** **Cahokia Alluvium**
Deposits of floodplains and channels of modern rivers and streams; mostly poorly sorted silt and sand containing local deposits of gravel.
- g** **Grayslake Peat**
Peat, muck, and locally marl; dominantly organic deposits with interbedded silt and clay in places; mostly in glacial lake basins.
- ed** **Equality Formation (Dolton facies)**
Largely shallow-water, near-shorelake sediments in beaches, bars, spits, and deltas; dominantly medium-grained sand; contains beds of silt; local lenses of sandy gravel along beaches.
- lp** **Lake plain (Wadsworth Formation)**
Floors of glacial lakes flattened by wave erosion; largely underlain by glacial till; occasional covered by thin deposits of silt, clay and sand of Equality Formation
- sl** **Glacial sluiceway**
Erosional channels; mostly outlets of glacial lakes where cut into till, cut into bedrock, as along Des Plaines Valley; contains local deposits of sand and gravel of Henry Formation.

- t** **Tinley Moraine;**
- tg** **Tinley groundmoraine;**
- cl** **Valparaiso Morainic System**
Clarendon Moraine;
- S** **Silurian Bedrock**
Largely dolostone, slightly to moderately argillaceous with scattered chert nodules; massive to well bedded dolomite with minor beds of shale and shaly dolomite.

Modified after Willman(1971)

REGIONAL GEOLOGY

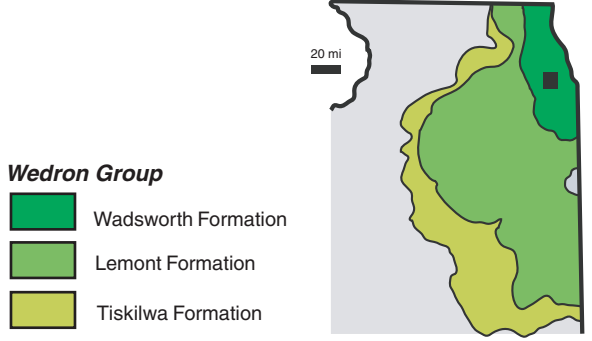

Modified after Hansel and Johnson (1996)

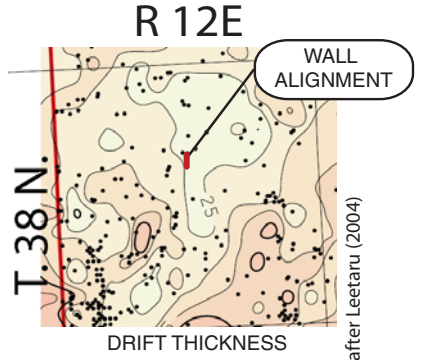

DRIFT THICKNESS

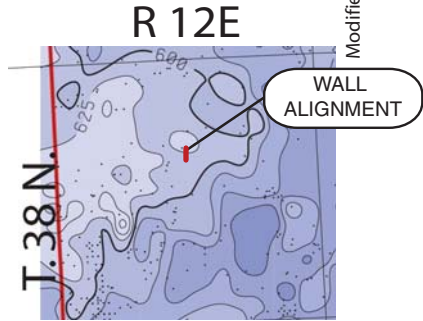

BEDROCK TOPOGRAPHY

Contour interval 25 feet

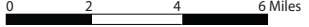

Modified after Leetaru (2004)

SITE AND REGIONAL GEOLOGY: EAST AVENUE FROM JOLIET TO 55TH STREET, RETAINING WALL, SN 016-Z022, COOK COUNTY



SCALE: GRAPHICAL | EXHIBIT 2 | DRAWN BY: C. Marin | CHECKED BY: L. Iordache

1145 N. Main Street
Lombard, IL 60148
www.wangeng.com

FOR ACCURATE GROUP, INC. | 491-03-01



Legend

-  Boring Locations
-  Historical Boring Locations
-  Proposed Retaining Wall

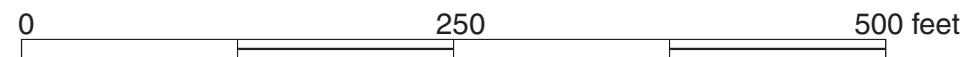

BORING LOCATION PLAN: EAST AVENUE FROM JOLIET ROAD TO 55TH STREET, RETAINING WALL, SN 016-Z022, COOK COUNTY

SCALE: GRAPHICAL	EXHIBIT 3	DRAWN BY: R. KC CHECKED BY: NSB
------------------	------------------	------------------------------------

	1145 N. Main Street Lombard, IL 60148 www.wangeng.com
	FOR ACCURATE GROUP, INC.

1145 N. Main Street
Lombard, IL 60148
www.wangeng.com

FOR ACCURATE GROUP, INC.

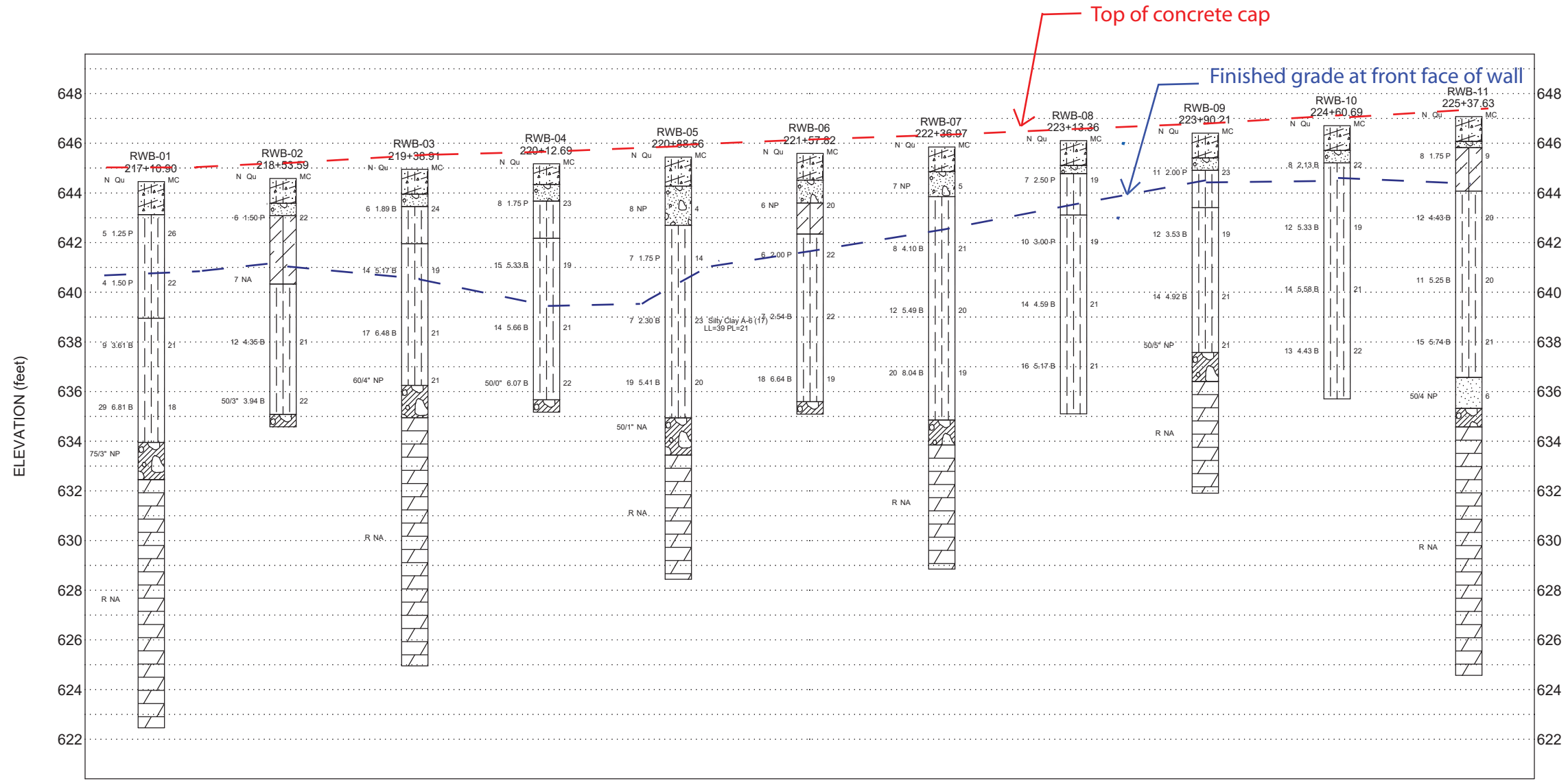
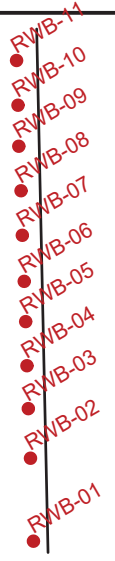

491-03-01



DISTANCE ALONG PROFILE (feet)

Lithology Graphics



-  Pavement
-  IDH Silty Clay, Silty Clay Loam
-  Weathered bedrock
-  Dolomite or Dolomitic Limestone
-  Gravelly sand, sandy gravel
-  IDH Clay Loam
-  IDH Sand, Sandy Loam

-  Top of concrete cap
-  Finished grade at front face of wall

Site Map Scale 1 inch equals 330 feet

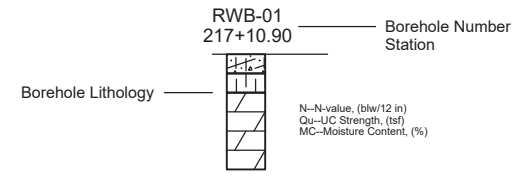
Explanation:



-  Water Level Reading at time of drilling.
-  Water Level Reading 24-hr after drilling or at end of drilling

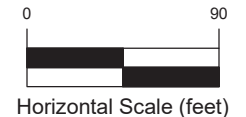

Vertical Exaggeration: 17x

Wang Engineering
1145 N Main Street
Lombard, IL 60148

Soil Profile Retaining Wall SN 016-Z022



East Avenue from Joliet Road to 55th Street
Cook County, IL

JOB NUMBER	PLATE NUMBER
491-03-01	EXHIBIT 4-1

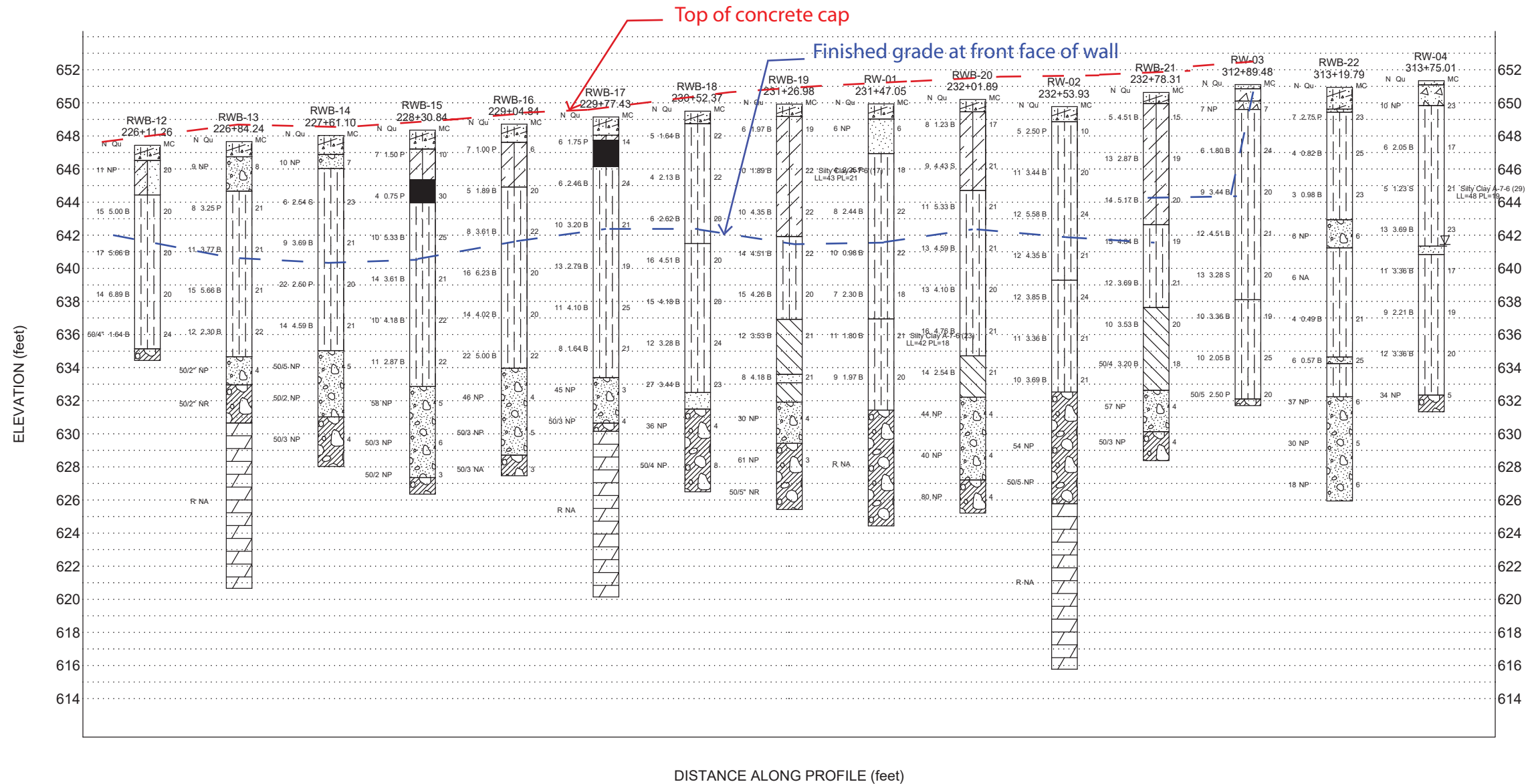
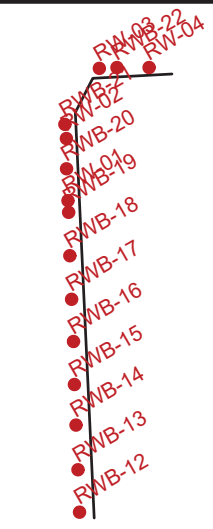

DISTANCE ALONG PROFILE (feet)

Lithology Graphics

- Pavement
- Dolomite or Dolomitic Limestone
- Gravelly sand, sandy gravel
- IDH Sand, Sandy Loam
- Concrete
- IDH Clay Loam
- IDH Silty Clay, Silty Clay Loam
- Crushed stone
- Topsoil
- Weathered bedrock
- IDH Loam
- IDH Clay

- Top of concrete cap
- Finished grade at front face of wall

Site Map Scale 1 inch equals 330 feet

Explanation:

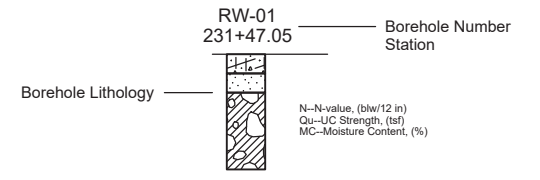

- Water Level Reading at time of drilling.
- Water Level Reading 24-hr after drilling or at end of drilling

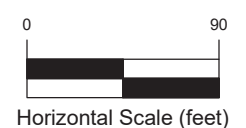

Horizontal Scale (feet)

Vertical Exaggeration: 11.5x

Wang Engineering
1145 N Main Street
Lombard, IL 60148

Soil Profile
Retaining Wall SN 016-Z022



East Avenue from Joliet Road to
55th Street
Cook County, IL

JOB NUMBER	PLATE NUMBER
491-03-01	EXHIBIT 4-2

APPENDIX A

LEGEND FOR BORING LOG

Relative Density of Non-Cohesive Soils	
N-Blows/ 12 inches	Relative Density Term
0-3	Very Loose
4-9	Loose
10-29	Medium Dense
30-49	Dense
50-80+	Very Dense

Consistency of Cohesive Soils	
Unconfined Compressive Strength Q_u , tsf	Consistency Term
<0.25	Very Soft
0.25-0.49	Soft
0.50-0.99	Medium Stiff
1.00-1.99	Stiff
2.00-3.99	Very Stiff
>4.00	Hard

Relative Drilling Resistace	
RDR	Drilling Resistance Term
1	Very Easy
2	Easy
3	Moderate
4	Hard
5	Very Hard

Proportional Terms		
Trace	1-9	Percent of Dry Weight
Little	10-19	
Some	20-34	
And	35-50	
Gradation Terminology		
Boulders	>200mm	
Cobbles	200mm to 75mm	
Gravel	75mm to 2mm	
Sand	2-0mm to 0.074mm	
Silt	0.074mm to 0.002mm	
Clay	<0.002mm	

Sample Type Symbols



Split Spoon



No Recovery



Geoprobe



Rock Core

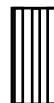

Shelby Tube



Auger Cuttings

SS = Split Spoon

ST = Shelby Tube

SPT = Standard Penetration Test

Q_u = Unconfined Compressive Strength

P = Pocket Penetrometer

S = Shear failure of sample, Rimac test

B = Bulge failure of sample, Rimac test

SSA = Solid Stem Augers,

HSA = Hollow Stem Augers,

Drill Rig:

TMR = Truck Mouted Rig

ATV = All Terrain Vehicle Rig

[--%] = SPT Hammer Efficiency



In-situ Vane Shear Test

SPT = Standard Penetration Test

N Value is the sum of the second and the third numbers



wangeng@wangeng.com
 1145 N Main Street
 Lombard, IL 60148
 Telephone: 630 953-9928
 Fax: 630 953-9938

BORING LOG RWB-01

WEI Job No.: 491-03-01

Client **Accurate Group, Inc.**
 Project **East Avenue from Joliet Road to 55th Street**
 Location **Cook County, IL**

Datum: NAVD 88
 Elevation: 644.46 ft
 North: 1864981.15 ft
 East: 1113709.25 ft
 Station: 217+10.90
 Offset: 16.11 RT

Profile	Elevation (ft)	SOIL AND ROCK DESCRIPTION	Depth (ft)	Sample Type recovery	Sample No.	SPT Values (blw/6 in)	Qu (tsf)	Moisture Content (%)	Profile	Elevation (ft)	SOIL AND ROCK DESCRIPTION	Depth (ft)	Sample Type recovery	Sample No.	SPT Values (blw/6 in)	Qu (tsf)	Moisture Content (%)
	643.1	16-inch thick ASPHALT --PAVEMENT--															
		Stiff, brown and gray SILTY CLAY LOAM, trace gravel; moist --FILL-- --RDR 2--	1		1	3 2 3	1.25 P	26		622.5	Boring terminated at 22.00 ft						
			2		2	2 2 2	1.50 P	22				25					
	639.0	Very stiff to hard, brown to gray SILTY CLAY, trace gravel; damp --RDR 2--	3		3	2 4 5	3.61 B	21									
			4		4	8 13 16	6.81 B	18									
	634.0	--hard drilling, from 10.5 feet--	10									30					
		Very dense, brown rock fragments --WEATHERED BEDROCK-- --RDR 4 to 5--	5		5	75/3	NP										
	632.5	Strong, light brownish gray, very poor rock mass quality, highly vuggy, moderately weathered DOLOSTONE, horizontal and vertical joints, 3-inch spaced joints, less than 0.05 to more than 0.2-inch joint opening, highly weathered infill to no infill, hard joint walls. --Run 1: 12.0 to 22.0 feet-- --RECOVERY = 100%-- --RQD = 0%--	15									35					
			20		6							40					

GENERAL NOTES

WATER LEVEL DATA

Begin Drilling **06-28-2017** Complete Drilling **06-28-2017**
 Drilling Contractor **Wang Testing Services** Drill Rig **CME55 TMR [85%]**
 Driller **R&J** Logger **F. Bozga** Checked by **C. Marin**
 Drilling Method **3.25 HSA; backfilled upon completion**

While Drilling **DRY**
 At Completion of Drilling **DRY**
 Time After Drilling **NA**
 Depth to Water **NA**

The stratification lines represent the approximate boundary between soil types; the actual transition may be gradual.



wangeng@wangeng.com
 1145 N Main Street
 Lombard, IL 60148
 Telephone: 630 953-9928
 Fax: 630 953-9938

BORING LOG RWB-02

WEI Job No.: 491-03-01

Client **Accurate Group, Inc.**
 Project **East Avenue from Joliet Road to 55th Street**
 Location **Cook County, IL**

Datum: NAVD 88
 Elevation: 644.58 ft
 North: 1865123.75 ft
 East: 1113704.21 ft
 Station: 218+53.59
 Offset: 16.20 RT

Profile	Elevation (ft)	SOIL AND ROCK DESCRIPTION	Depth (ft)	Sample Type recovery	Sample No.	SPT Values (blw/6 in)	Qu (tsf)	Moisture Content (%)	Profile	Elevation (ft)	SOIL AND ROCK DESCRIPTION	Depth (ft)	Sample Type recovery	Sample No.	SPT Values (blw/6 in)	Qu (tsf)	Moisture Content (%)
	643.6	12-inch thick ASPHALT --PAVEMENT--															
	643.1	Loose, gray SANDY GRAVEL; moist --AGGREGATE BASE-- --RDR 2--			1	6 3 3	1.50 P	22									
	640.3	Stiff, brown CLAY LOAM, trace gravel; moist --FILL-- --RDR 2--			2	3 3 4											
		Very stiff to hard, brown to gray SILTY CLAY, trace gravel; moist --RDR 2--	5														
					3	4 5 7	4.35 B	21									
	635.1				4	5 7	3.94 B	22									
	634.6	Brown, rock fragments --WEATHERED BEDROCK-- --AUGER REFUSAL-- Boring terminated at 10.00 ft	10			50/3"											

GENERAL NOTES

WATER LEVEL DATA

Begin Drilling **06-28-2017** Complete Drilling **06-28-2017**
 Drilling Contractor **Wang Testing Services** Drill Rig **CME55 TMR [85%]**
 Driller **R&J** Logger **F. Bozga** Checked by **C. Marin**
 Drilling Method **3.25 HSA; backfilled upon completion**

While Drilling ∇ **DRY**
 At Completion of Drilling ∇ **DRY**
 Time After Drilling **NA**
 Depth to Water ∇ **NA**

The stratification lines represent the approximate boundary between soil types; the actual transition may be gradual.



wangeng@wangeng.com
 1145 N Main Street
 Lombard, IL 60148
 Telephone: 630 953-9928
 Fax: 630 953-9938

BORING LOG RWB-03

WEI Job No.: 491-03-01

Client **Accurate Group, Inc.**
 Project **East Avenue from Joliet Road to 55th Street**
 Location **Cook County, IL**

Datum: NAVD 88
 Elevation: 644.95 ft
 North: 1865208.99 ft
 East: 1113700.45 ft
 Station: 219+38.91
 Offset: 15.51 RT

Profile	Elevation (ft)	SOIL AND ROCK DESCRIPTION	Depth (ft)	Sample Type recovery	Sample No.	SPT Values (blw/6 in)	Qu (tsf)	Moisture Content (%)	Profile	Elevation (ft)	SOIL AND ROCK DESCRIPTION	Depth (ft)	Sample Type recovery	Sample No.	SPT Values (blw/6 in)	Qu (tsf)	Moisture Content (%)
	644.0	12-inch thick ASPHALT --PAVEMENT--															
	643.5	Loose, gray SANDY GRAVEL; moist --AGGREGATE BASE-- --RDR 2--	1		1	2 2 4	1.89 B	24									
	642.0	Stiff, brown SILTY CLAY LOAM, trace gravel --FILL-- --RDR 2--	2		2	3 6 8	5.17 B	19									
		Hard, brown SILTY CLAY, trace gravel	5		3	4 7 10	6.48 B	21									
	636.3	Very dense, rock fragments --WEATHERED BEDROCK-- --RDR 5--	4		4	60/4	NP	21									
	635.0	Strong, light brownish gray, very poor rock mass quality, highly vuggy, moderately weathered DOLOSTONE, horizontal and vertical joints, 2-inch spaced joints, less than 0.05 to more than 0.2-inch joint opening, more than 0.2-inch highly weathered infill, hard joint walls. --Run 1: 10.0 to 20.0 feet-- --RECOVERY = 100%-- --RQD = 0%--	15		5												
	625.0	Boring terminated at 20.00 ft	20														

WANGENG 4910301.GPJ WANGENG.GDT 1/25/18

GENERAL NOTES

WATER LEVEL DATA

Begin Drilling **06-28-2017** Complete Drilling **06-28-2017**
 Drilling Contractor **Wang Testing Services** Drill Rig **CME55 TMR [85%]**
 Driller **R&J** Logger **F. Bozga** Checked by **C. Marin**
 Drilling Method **3.25.HSA; backfilled upon completion**

While Drilling **DRY**
 At Completion of Drilling **DRY**
 Time After Drilling **NA**
 Depth to Water **NA**

The stratification lines represent the approximate boundary between soil types; the actual transition may be gradual.



wangeng@wangeng.com
 1145 N Main Street
 Lombard, IL 60148
 Telephone: 630 953-9928
 Fax: 630 953-9938

BORING LOG RWB-04

WEI Job No.: 491-03-01

Client **Accurate Group, Inc.**
 Project **East Avenue from Joliet Road to 55th Street**
 Location **Cook County, IL**

Datum: NAVD 88
 Elevation: 645.17 ft
 North: 1865282.73 ft
 East: 1113698.11 ft
 Station: 220+12.69
 Offset: 15.83 RT

Profile	Elevation (ft)	SOIL AND ROCK DESCRIPTION	Depth (ft)	Sample Type recovery	Sample No.	SPT Values (blw/6 in)	Qu (tsf)	Moisture Content (%)	Profile	Elevation (ft)	SOIL AND ROCK DESCRIPTION	Depth (ft)	Sample Type recovery	Sample No.	SPT Values (blw/6 in)	Qu (tsf)	Moisture Content (%)
	644.3	10-inch thick ASPHALT --PAVEMENT--															
	643.7	Loose, gray SANDY GRAVEL; moist --AGGREGATE BASE-- --RDR 2--			1	2 3 5	1.75 P	23									
	642.2	Stiff, brown SILTY CLAY LOAM; moist --FILL-- --RDR 2--			2	5 6 9	5.33 B	19									
		Hard, brown SILTY CLAY, trace gravel; damp --RDR 2--			3	4 5 9	5.66 B	21									
					4	5 7	6.07 B	22									
	635.7	Very dense, rock fragments --WEATHERED BEDROCK-- --RDR 5-- --AUGER REFUSAL--	10			50/0"											
	635.2	Boring terminated at 10.00 ft															

GENERAL NOTES

WATER LEVEL DATA

Begin Drilling **06-28-2017** Complete Drilling **06-28-2017**
 Drilling Contractor **Wang Testing Services** Drill Rig **CME55 TMR [85%]**
 Driller **R&J** Logger **F. Bozga** Checked by **C. Marin**
 Drilling Method **3.25 HSA; backfilled upon completion**

While Drilling **DRY**
 At Completion of Drilling **DRY**
 Time After Drilling **NA**
 Depth to Water **NA**

The stratification lines represent the approximate boundary between soil types; the actual transition may be gradual.



wangeng@wangeng.com
 1145 N Main Street
 Lombard, IL 60148
 Telephone: 630 953-9928
 Fax: 630 953-9938

BORING LOG RWB-05

WEI Job No.: 491-03-01

Client **Accurate Group, Inc.**
 Project **East Avenue from Joliet Road to 55th Street**
 Location **Cook County, IL**

Datum: NAVD 88
 Elevation: 645.44 ft
 North: 1865358.57 ft
 East: 1113695.90 ft
 Station: 220+88.56
 Offset: 16.35 RT

Profile	Elevation (ft)	SOIL AND ROCK DESCRIPTION	Depth (ft)	Sample Type recovery	Sample No.	SPT Values (blw/6 in)	Qu (tsf)	Moisture Content (%)	Profile	Elevation (ft)	SOIL AND ROCK DESCRIPTION	Depth (ft)	Sample Type recovery	Sample No.	SPT Values (blw/6 in)	Qu (tsf)	Moisture Content (%)
	644.3	14-inch thick ASPHALT --PAVEMENT--															
	642.7	Loose, gray SANDY GRAVEL; dry --AGGREGATE BASE-- --RDR 2--			1	9 4 4	NP	4									
		Stiff to hard, brown SILTY CLAY to SILTY CLAY LOAM, trace gravel; damp --RDR 2--	5		2	2 3 4	1.75 P	14									
		--L _L (%)=39, P _L (%)=21-- --%Gravel=0.8-- --%Sand=9.2-- --%Silt=51.0-- --%Clay=39.0-- --A-6 (17)--			3	2 3 4	2.30 B	23									
			10		4	4 7 12	5.41 B	20									
	634.9	--hard drilling from 10.5 feet-- --WEATHERED BEDROCK-- --RDR 4 to 5--			5												
	633.4	Strong, light brownish gray, very poor rock mass quality, highly vuggy, moderately weathered DOLOSTONE, horizontal and vertical joints, 0.5-inch spaced joints, 0.05 to more than 0.2-inch joint opening, more than 0.2-inch highly weathered infill, hard joint walls. --Run 1: 12.0 to 17.0 feet-- --RECOVERY = 100%-- --RQD = 0%--	15		6												
	628.4	Boring terminated at 17.00 ft	20														

GENERAL NOTES

WATER LEVEL DATA

Begin Drilling **06-29-2017** Complete Drilling **06-29-2017**
 Drilling Contractor **Wang Testing Services** Drill Rig **CME55 TMR [85%]**
 Driller **R&J** Logger **F. Bozga** Checked by **C. Marin**
 Drilling Method **3.25 HSA; backfilled upon completion**

While Drilling ∇ **DRY**
 At Completion of Drilling ∇ **DRY**
 Time After Drilling **NA**
 Depth to Water ∇ **NA**

The stratification lines represent the approximate boundary between soil types; the actual transition may be gradual.



wangeng@wangeng.com
 1145 N Main Street
 Lombard, IL 60148
 Telephone: 630 953-9928
 Fax: 630 953-9938

BORING LOG RWB-06

WEI Job No.: 491-03-01

Client **Accurate Group, Inc.**
 Project **East Avenue from Joliet Road to 55th Street**
 Location **Cook County, IL**

Datum: NAVD 88
 Elevation: 645.59 ft
 North: 1865427.78 ft
 East: 1113693.39 ft
 Station: 221+57.82
 Offset: 16.33 RT

Profile	Elevation (ft)	SOIL AND ROCK DESCRIPTION	Depth (ft)	Sample Type recovery	Sample No.	SPT Values (blw/6 in)	Qu (tsf)	Moisture Content (%)	Profile	Elevation (ft)	SOIL AND ROCK DESCRIPTION	Depth (ft)	Sample Type recovery	Sample No.	SPT Values (blw/6 in)	Qu (tsf)	Moisture Content (%)
	644.5	13-inch thick ASPHALT --PAVEMENT--															
	643.6	Gray SANDY GRAVEL; dry --AGGREGATE BASE--				4											
	642.3	Stiff, brown CLAY LOAM, trace gravel; moist --FILL-- --RDR 2--			1	4 4 2	NP	20									
		Very stiff to hard, brown and gray SILTY CLAY; damp --RDR 2--			2	2 3 3	2.00 P	22									
					3	3 3 4	2.54 B	22									
					4	3 7 11	6.64 B	19									
	635.6	--WEATHERED BEDROCK-- --RDR 5--	10														
	635.1	--AUGER REFUSAL-- Boring terminated at 10.50 ft															

GENERAL NOTES

WATER LEVEL DATA

Begin Drilling **06-29-2017** Complete Drilling **06-29-2017**
 Drilling Contractor **Wang Testing Services** Drill Rig **CME55 TMR [85%]**
 Driller **R&J** Logger **F. Bozga** Checked by **C. Marin**
 Drilling Method **3.25 HSA; backfilled upon completion**

While Drilling ∇ **DRY**
 At Completion of Drilling ∇ **DRY**
 Time After Drilling **NA**
 Depth to Water ∇ **NA**

The stratification lines represent the approximate boundary between soil types; the actual transition may be gradual.



wangeng@wangeng.com
 1145 N Main Street
 Lombard, IL 60148
 Telephone: 630 953-9928
 Fax: 630 953-9938

BORING LOG RWB-07

WEI Job No.: 491-03-01

Client **Accurate Group, Inc.**
 Project **East Avenue from Joliet Road to 55th Street**
 Location **Cook County, IL**

Datum: NAVD 88
 Elevation: 645.85 ft
 North: 1865506.87 ft
 East: 1113690.14 ft
 Station: 222+36.97
 Offset: 15.92 RT

Profile	Elevation (ft)	SOIL AND ROCK DESCRIPTION	Depth (ft)	Sample Type recovery	Sample No.	SPT Values (blw/6 in)	Qu (tsf)	Moisture Content (%)	Profile	Elevation (ft)	SOIL AND ROCK DESCRIPTION	Depth (ft)	Sample Type recovery	Sample No.	SPT Values (blw/6 in)	Qu (tsf)	Moisture Content (%)
		12-inch thick ASPHALT --PAVEMENT--															
	644.9																
	643.9	12-inch thick, gray SANDY GRAVEL; dry --AGGREGATE BASE-- --RDR 2--			1	4 3 4	NP	5									
		Hard, brown SILTY CLAY; damp --RDR 2--			2	2 3 5	4.10 B	21									
					3	4 5 7	5.49 B	20									
					4	4 8 12	8.04 B	19									
	634.9	--hard drilling from 11.0 feet-- --WEATHERED BEDROCK-- --RDR 4 to 5--															
	633.9																
		Strong, light brownish gray, very poor rock mass quality, highly vuggy, moderately weathered DOLOSTONE, horizontal and vertical joints, 0.75-inch spaced joints, 0.05 to more than 0.2-inch joint opening, more than 0.2-inch highly weathered infill, hard joint walls. --Run 1: 12.0 to 17.0 feet-- --RECOVERY = 100%-- --RQD = 0%--			1												
	628.9																
		Boring terminated at 17.00 ft															

GENERAL NOTES

WATER LEVEL DATA

Begin Drilling **06-29-2017** Complete Drilling **06-29-2017**
 Drilling Contractor **Wang Testing Services** Drill Rig **CME55 TMR [85%]**
 Driller **R&J** Logger **F. Bozga** Checked by **C. Marin**
 Drilling Method **3.25 HSA; backfilled upon completion**

While Drilling ∇ **DRY**
 At Completion of Drilling ∇ **DRY**
 Time After Drilling **NA**
 Depth to Water ∇ **NA**

The stratification lines represent the approximate boundary between soil types; the actual transition may be gradual.



wangeng@wangeng.com
 1145 N Main Street
 Lombard, IL 60148
 Telephone: 630 953-9928
 Fax: 630 953-9938

BORING LOG RWB-08

WEI Job No.: 491-03-01

Client **Accurate Group, Inc.**
 Project **East Avenue from Joliet Road to 55th Street**
 Location **Cook County, IL**

Datum: NAVD 88
 Elevation: 646.11 ft
 North: 1865583.47 ft
 East: 1113687.91 ft
 Station: 223+13.36
 Offset: 16.45 RT

Profile	Elevation (ft)	SOIL AND ROCK DESCRIPTION	Depth (ft)	Sample Type recovery	Sample No.	SPT Values (blw/6 in)	Qu (tsf)	Moisture Content (%)	Profile	Elevation (ft)	SOIL AND ROCK DESCRIPTION	Depth (ft)	Sample Type recovery	Sample No.	SPT Values (blw/6 in)	Qu (tsf)	Moisture Content (%)
		12-inch thick, ASPHALT --PAVEMENT--															
	645.1																
	644.84	4-inch thick, loose, gray SANDY GRAVEL --AGGREGATE BASE--			1	3 3 4	2.50 P	19									
	643.1	Very stiff, brown SILTY CLAY; damp --FILL-- --RDR 2--			2	5 5 5	3.00 P	19									
		Very stiff to hard, brown SILTY CLAY, trace gravel; damp --RDR 2--	5														
					3	5 6 8	4.59 B	21									
					4	5 6 10	5.17 B	21									
		--hard drilling, 10.5 to 11 feet-- --AUGER REFUSAL--	10														
	635.1	Boring terminated at 11.00 ft															
			15														
			20														

GENERAL NOTES

WATER LEVEL DATA

Begin Drilling **06-30-2017** Complete Drilling **06-30-2017**
 Drilling Contractor **Wang Testing Services** Drill Rig **CME55 TMR [85%]**
 Driller **R&J** Logger **F. Bozga** Checked by **C. Marin**
 Drilling Method **3.25 HSA; backfilled upon completion**

While Drilling **DRY**
 At Completion of Drilling **DRY**
 Time After Drilling **NA**
 Depth to Water **NA**

The stratification lines represent the approximate boundary between soil types; the actual transition may be gradual.



wangeng@wangeng.com
 1145 N Main Street
 Lombard, IL 60148
 Telephone: 630 953-9928
 Fax: 630 953-9938

BORING LOG RWB-09

WEI Job No.: 491-03-01

Client **Accurate Group, Inc.**
 Project **East Avenue from Joliet Road to 55th Street**
 Location **Cook County, IL**

Datum: NAVD 88
 Elevation: 646.41 ft
 North: 1865659.99 ft
 East: 1113684.05 ft
 Station: 223+90.21
 Offset: 15.35 RT

Profile	Elevation (ft)	SOIL AND ROCK DESCRIPTION	Depth (ft)	Sample Type recovery	Sample No.	SPT Values (blw/6 in)	Qu (tsf)	Moisture Content (%)	Profile	Elevation (ft)	SOIL AND ROCK DESCRIPTION	Depth (ft)	Sample Type recovery	Sample No.	SPT Values (blw/6 in)	Qu (tsf)	Moisture Content (%)
		12-inch thick ASPHALT --PAVEMENT--															
	645.4																
	644.9	Gray SANDY GRAVEL; dry --AGGREGATE BASE-- --RDR 2--			1	3 4 7	2.00 P	23									
	643.4	Very stiff, brown SILTY CLAY; damp --FILL-- --RDR 2--			2	3 5 7	3.53 B	19									
		Very stiff to hard, brown and gray to brown SILTY CLAY, trace gravel; damp --RDR 2--	5														
					3	4 6 8	4.92 B	21									
	637.6	Very dense, rock fragments --WEATHERED BEDROCK-- --RDR 5--10			4	50/5"	NP	21									
	636.4																
		Strong, light brownish gray, very poor rock mass quality, highly vuggy, highly weathered DOLOSTONE, horizontal and vertical joints, 0.7-inch spaced joints, 0.05 to more than 0.2-inch joint opening, more than 0.2-inch highly weathered infill, hard joint walls. --Run 1: 10.0 to 14.5 feet-- --RECOVERY = 100%-- --RQD = 0%--			5												
	631.9	Boring terminated at 14.50 ft															

GENERAL NOTES

WATER LEVEL DATA

Begin Drilling **06-29-2017** Complete Drilling **06-29-2017**
 Drilling Contractor **Wang Testing Services** Drill Rig **CME55 TMR [85%]**
 Driller **R&J** Logger **F. Bozga** Checked by **C. Marin**
 Drilling Method **3.25 HSA; backfilled upon completion**

While Drilling ∇ **DRY**
 At Completion of Drilling ∇ **DRY**
 Time After Drilling **NA**
 Depth to Water ∇ **NA**

The stratification lines represent the approximate boundary between soil types; the actual transition may be gradual.



wangeng@wangeng.com
 1145 N Main Street
 Lombard, IL 60148
 Telephone: 630 953-9928
 Fax: 630 953-9938

BORING LOG RWB-10

WEI Job No.: 491-03-01

Client **Accurate Group, Inc.**
 Project **East Avenue from Joliet Road to 55th Street**
 Location **Cook County, IL**

Datum: NAVD 88
 Elevation: 646.71 ft
 North: 1865730.47 ft
 East: 1113682.71 ft
 Station: 224+60.69
 Offset: 16.55 RT

Profile	Elevation (ft)	SOIL AND ROCK DESCRIPTION	Depth (ft)	Sample Type recovery	Sample No.	SPT Values (blw/6 in)	Qu (tsf)	Moisture Content (%)	Profile	Elevation (ft)	SOIL AND ROCK DESCRIPTION	Depth (ft)	Sample Type recovery	Sample No.	SPT Values (blw/6 in)	Qu (tsf)	Moisture Content (%)
		12-inch thick, ASPHALT															
	645.7																
	645.2	6-inch thick, gray SANDY GRAVEL; dry --AGGREGATE BASE--			1	3 3 5	2.13 B	22									
		Very stiff to hard, brown and gray SILTY CLAY, trace gravel; damp --RDR 2--															
			5		2	4 5 7	5.33 B	19									
					3	4 6 8	5.58 B	21									
					4	4 5 8	4.43 B	22									
		--hard drilling, 10 to 11 feet-- --RDR 5--	10														
		--AUGER REFUSAL--															
	635.7	Boring terminated at 11.00 ft															
			15														
			20														

GENERAL NOTES

WATER LEVEL DATA

Begin Drilling **06-30-2017** Complete Drilling **06-30-2017**
 Drilling Contractor **Wang Testing Services** Drill Rig **CME55 TMR [85%]**
 Driller **R&J** Logger **F. Bozga** Checked by **C. Marin**
 Drilling Method **3.25 HSA; backfilled upon completion**

While Drilling ∇ **DRY**
 At Completion of Drilling ∇ **DRY**
 Time After Drilling **NA**
 Depth to Water ∇ **NA**

The stratification lines represent the approximate boundary between soil types; the actual transition may be gradual.



wangeng@wangeng.com
 1145 N Main Street
 Lombard, IL 60148
 Telephone: 630 953-9928
 Fax: 630 953-9938

BORING LOG RWB-11

WEI Job No.: 491-03-01

Client **Accurate Group, Inc.**
 Project **East Avenue from Joliet Road to 55th Street**
 Location **Cook County, IL**

Datum: NAVD 88
 Elevation: 647.08 ft
 North: 1865807.37 ft
 East: 1113680.25 ft
 Station: 225+37.63
 Offset: 16.86 RT

Profile	Elevation (ft)	SOIL AND ROCK DESCRIPTION	Depth (ft)	Sample Type recovery	Sample No.	SPT Values (blw/6 in)	Qu (tsf)	Moisture Content (%)	Profile	Elevation (ft)	SOIL AND ROCK DESCRIPTION	Depth (ft)	Sample Type recovery	Sample No.	SPT Values (blw/6 in)	Qu (tsf)	Moisture Content (%)
		12-inch thick, ASPHALT --PAVEMENT--															
	646.1 645.8	3-inch thick, gray SANDY GRAVEL --AGGREGATE BASE--			1	3 4 4	1.75 P	9		624.6	Boring terminated at 22.50 ft						
	644.1	Stiff, brown CLAY LOAM, trace gravel; dry --FILL-- --RDR 2--			2	3 5 7	4.43 B	20				25					
		Hard, brown SILTY CLAY, trace gravel; damp --RDR 2--			3	4 4 7	5.25 B	20									
					4	5 6 9	5.74 B	21				30					
	636.6	Very dense, brown, medium SAND; moist			5	3	NP	6									
	635.3	--hard drilling, 11.75 to 12.5 feet-- --WEATHERED BEDROCK--			6												
	634.6	Strong, light brownish gray, very poor rock mass quality, highly vuggy and fragmented, moderately weathered DOLOSTONE, 1-inch spacing of joints, horizontal and vertical joints, 0.05 to greater than 0.2-inch joint opening, none to less than 0.2-inch highly weathered infill, rough and hard joint walls. --Run 1: 12.5 to 22.5 feet-- --RECOVERY = 95%-- --RQD = 0%--										35					
												40					

GENERAL NOTES

Begin Drilling **06-30-2017** Complete Drilling **06-30-2017**
 Drilling Contractor **Wang Testing Services** Drill Rig **CME55 TMR [85%]**
 Driller **R&J** Logger **F. Bozga** Checked by **C. Marin**
 Drilling Method **3.25 HSA; backfilled upon completion**

WATER LEVEL DATA

While Drilling **DRY**
 At Completion of Drilling **DRY**
 Time After Drilling **NA**
 Depth to Water **NA**

The stratification lines represent the approximate boundary between soil types; the actual transition may be gradual.



wangeng@wangeng.com
 1145 N Main Street
 Lombard, IL 60148
 Telephone: 630 953-9928
 Fax: 630 953-9938

BORING LOG RWB-12

WEI Job No.: 491-03-01

Client **Accurate Group, Inc.**
 Project **East Avenue from Joliet Road to 55th Street**
 Location **Cook County, IL**

Datum: NAVD 88
 Elevation: 647.44 ft
 North: 1865880.95 ft
 East: 1113677.41 ft
 Station: 226+11.26
 Offset: 16.66 RT

Profile	Elevation (ft)	SOIL AND ROCK DESCRIPTION	Depth (ft)	Sample Type recovery	Sample No.	SPT Values (blw/6 in)	Qu (tsf)	Moisture Content (%)	Profile	Elevation (ft)	SOIL AND ROCK DESCRIPTION	Depth (ft)	Sample Type recovery	Sample No.	SPT Values (blw/6 in)	Qu (tsf)	Moisture Content (%)
	646.5	11-inch thick, ASPHALT --PAVEMENT--															
	644.4	Medium dense, dark gray GRAVELLY LOAM --FILL-- --RDR 2--			1	4 7 4	NP	20									
		Stiff to hard, brown and gray SILTY CLAY --RDR 2--	5		2	4 6 9	5.00 B	20									
					3	5 7 10	5.66 B	20									
			10		4	3 6 8	6.89 B	20									
	635.1	--RDR 5--			5	3 3	1.64 B	24									
	634.4	--hard drilling, 12.3 to 13 feet-- --WEATHERED BEDROCK-- --AUGER REFUSAL-- Boring terminated at 13.00 ft				50/4"											

GENERAL NOTES

WATER LEVEL DATA

Begin Drilling **06-30-2017** Complete Drilling **06-30-2017**
 Drilling Contractor **Wang Testing Services** Drill Rig **CME55 TMR [85%]**
 Driller **R&J** Logger **F. Bozga** Checked by **C. Marin**
 Drilling Method **3.25 HSA; backfilled upon completion**

While Drilling ∇ **DRY**
 At Completion of Drilling ∇ **DRY**
 Time After Drilling **NA**
 Depth to Water ∇ **NA**

The stratification lines represent the approximate boundary between soil types; the actual transition may be gradual.



wangeng@wangeng.com
 1145 N Main Street
 Lombard, IL 60148
 Telephone: 630 953-9928
 Fax: 630 953-9938

BORING LOG RWB-13

WEI Job No.: 491-03-01

Client **Accurate Group, Inc.**
 Project **East Avenue from Joliet Road to 55th Street**
 Location **Cook County, IL**

Datum: NAVD 88
 Elevation: 647.66 ft
 North: 1865953.88 ft
 East: 1113674.81 ft
 Station: 226+84.24
 Offset: 16.69 RT

Profile	Elevation (ft)	SOIL AND ROCK DESCRIPTION	Depth (ft)	Sample Type recovery	Sample No.	SPT Values (blw/6 in)	Qu (tsf)	Moisture Content (%)	Profile	Elevation (ft)	SOIL AND ROCK DESCRIPTION	Depth (ft)	Sample Type recovery	Sample No.	SPT Values (blw/6 in)	Qu (tsf)	Moisture Content (%)
	646.7	11-inch thick, ASPHALT --PAVEMENT--															
	644.7	Gray SANDY GRAVEL; damp --AGGREGATE BASE--			1	6 6 3	NP	8			less than 0.2-inch infill, rough and hard joint walls. --Run 1: 17 to 27 feet-- --RECOVERY = 100%-- --RQD = 0%-- --Q _u =5520 psi			8			
	644.7	Very stiff to hard, brown and gray SILTY CLAY, trace gravel; moist --RDR 2--			2	4 4 4	3.25 P	21				25					
			5														
					3	4 5 6	3.77 B	21		620.7	Boring terminated at 27.00 ft						
					4	3 6 9	5.66 B	21				30					
			10														
					5	4 5 7	2.30 B	22									
	634.7	Very dense, brown SANDY GRAVEL, some weathered dolostone fragments; damp --RDR 4--			6	10 40	NP	4									
	633.0	--WEATHERED BEDROCK-- --RDR 5--			7	50/2"	NR					35					
	630.7	Strong, light greyish gray, very poor rock mass quality, highly vuggy, moderately weathered DOLOSTONE, 2-inch spacing of joints, horizontal and vertical joints, 0.05 to greater than 0.2-inch joint opening, none to				50/2"											
			20									40					

WANGENGINC 4910301.GPJ WANGENG.GDT 1/25/18

GENERAL NOTES

Begin Drilling **06-30-2017** Complete Drilling **06-30-2017**
 Drilling Contractor **Wang Testing Services** Drill Rig **CME55 TMR [85%]**
 Driller **R&J** Logger **F. Bozga** Checked by **C. Marin**
 Drilling Method **3.25 HSA; backfilled upon completion**

WATER LEVEL DATA

While Drilling ∇ **DRY**
 At Completion of Drilling ∇ **DRY**
 Time After Drilling **NA**
 Depth to Water ∇ **NA**

The stratification lines represent the approximate boundary between soil types; the actual transition may be gradual.



wangeng@wangeng.com
 1145 N Main Street
 Lombard, IL 60148
 Telephone: 630 953-9928
 Fax: 630 953-9938

BORING LOG RWB-14

WEI Job No.: 491-03-01

Client **Accurate Group, Inc.**
 Project **East Avenue from Joliet Road to 55th Street**
 Location **Cook County, IL**

Datum: NAVD 88
 Elevation: 648.03 ft
 North: 1866030.67 ft
 East: 1113671.38 ft
 Station: 227+61.10
 Offset: 16.02 RT

Profile	Elevation (ft)	SOIL AND ROCK DESCRIPTION	Depth (ft)	Sample Type recovery	Sample No.	SPT Values (blw/6 in)	Qu (tsf)	Moisture Content (%)	Profile	Elevation (ft)	SOIL AND ROCK DESCRIPTION	Depth (ft)	Sample Type recovery	Sample No.	SPT Values (blw/6 in)	Qu (tsf)	Moisture Content (%)
	646.9	14-inch thick ASPHALT --PAVEMENT--															
	646.0	Medium dense, brown SANDY LOAM, trace gravel; dry --AGGREGATE BASE--			1	8 5 5	NP	7									
		Very stiff to hard, brown to gray SILTY CLAY, trace gravel; moist --RDR 2--	5		2	3 2 4	2.54 S	23									
					3	2 4 5	3.69 B	21									
					4	6 9 13	2.50 P	20									
					5	3 7 7	4.59 B	21									
	635.0	Very dense, brown GRAVELLY SAND, some weathered dolostone fragments; damp --RDR 4--	15		6	11 33 50/5	NP	5									
					7		NP										
	631.0	--difficult drilling from 17 feet-- --WEATHERED BEDROCK-- --very hard, steady drilling, from 18 feet-- --RDR 5--			8	50/2	NP	4									
	628.0	Boring terminated at 20.00 ft	20														

GENERAL NOTES

WATER LEVEL DATA

Begin Drilling **08-07-2017** Complete Drilling **08-07-2017**
 Drilling Contractor **Wang Testing Services** Drill Rig **B57 TMR [100%]**
 Driller **N&N** Logger **A. Tomaras** Checked by **C. Marin**
 Drilling Method **2.25 HSA; backfilled upon completion**

While Drilling ∇ **DRY**
 At Completion of Drilling ∇ **DRY**
 Time After Drilling **NA**
 Depth to Water ∇ **NA**

The stratification lines represent the approximate boundary between soil types; the actual transition may be gradual.

WANGENGINC 4910301.GPJ WANGENG.GDT 1/25/18



wangeng@wangeng.com
 1145 N Main Street
 Lombard, IL 60148
 Telephone: 630 953-9928
 Fax: 630 953-9938

BORING LOG RWB-15

WEI Job No.: 491-03-01

Client **Accurate Group, Inc.**
 Project **East Avenue from Joliet Road to 55th Street**
 Location **Cook County, IL**

Datum: NAVD 88
 Elevation: 648.36 ft
 North: 1866100.36 ft
 East: 1113668.61 ft
 Station: 228+30.84
 Offset: 15.76 RT

Profile	Elevation (ft)	SOIL AND ROCK DESCRIPTION	Depth (ft)	Sample Type recovery	Sample No.	SPT Values (blw/6 in)	Qu (tsf)	Moisture Content (%)	Profile	Elevation (ft)	SOIL AND ROCK DESCRIPTION	Depth (ft)	Sample Type recovery	Sample No.	SPT Values (blw/6 in)	Qu (tsf)	Moisture Content (%)
	647.2	14-inch thick ASPHALT --PAVEMENT--								627.4	--WEATHERED BEDROCK--			9			
		Stiff, black, brown, and gray CLAY LOAM, trace gravel; damp --FILL--			1	5 3 4	1.50 P	10		626.4	--RDR 4--				50/2		3
	645.4	Medium stiff, black and dark gray SILTY CLAY; moist --BURIED TOPSOIL--			2	2 1 3	0.75 P	30		Boring terminated at 22.00 ft							
	644.0	Very stiff to hard, brown to gray SILTY CLAY, trace gravel; moist --RDR 2--	5		5												
					3	2 4 6	5.33 B	25									
					4	4 6 8	3.61 B	21									
			10		5	3 4 6	4.18 B	22									
					6	4 5 6	2.87 B	22									
			15		7	22 38 20	NP	5									
	632.9	Very dense, brown and gray GRAVELLY SAND, some weathered dolostone fragments; damp --RDR 4--			8	33 23	NP	6									
						50/3											
			20														

GENERAL NOTES

WATER LEVEL DATA

Begin Drilling **08-07-2017** Complete Drilling **08-07-2017**
 Drilling Contractor **Wang Testing Services** Drill Rig **B57 TMR [100%]**
 Driller **N&N** Logger **A. Tomaras** Checked by **C. Marin**
 Drilling Method **2.25 HSA; backfilled upon completion**

While Drilling ∇ **DRY**
 At Completion of Drilling ∇ **DRY**
 Time After Drilling **NA**
 Depth to Water ∇ **NA**

The stratification lines represent the approximate boundary between soil types; the actual transition may be gradual.

WANGENGINC 4910301.GPJ WANGENG.GDT 1/25/18



wangeng@wangeng.com
 1145 N Main Street
 Lombard, IL 60148
 Telephone: 630 953-9928
 Fax: 630 953-9938

BORING LOG RWB-16

WEI Job No.: 491-03-01

Client **Accurate Group, Inc.**
 Project **East Avenue from Joliet Road to 55th Street**
 Location **Cook County, IL**

Datum: NAVD 88
 Elevation: 648.72 ft
 North: 1866174.34 ft
 East: 1113666.99 ft
 Station: 229+04.84
 Offset: 16.81 RT

Profile	Elevation (ft)	SOIL AND ROCK DESCRIPTION	Depth (ft)	Sample Type recovery	Sample No.	SPT Values (blw/6 in)	Qu (tsf)	Moisture Content (%)	Profile	Elevation (ft)	SOIL AND ROCK DESCRIPTION	Depth (ft)	Sample Type recovery	Sample No.	SPT Values (blw/6 in)	Qu (tsf)	Moisture Content (%)
	647.6	13-inch thick ASPHALT --PAVEMENT--								627.5	--difficult drilling from 20 feet-- --WEATHERED BEDROCK--			9			
		Stiff, black and brown CLAY LOAM, little gravel; damp --FILL-- --RDR 2 to 3--			1	4 2 5	1.00 P	6			Boring terminated at 21.25 ft				50/3		3
	644.9	Stiff to hard, brown to gray CLAY to SILTY CLAY, trace gravel; moist --RDR 2 to 3--	5		2	1 2 3	1.89 B	20				25					
					3	2 4 4	3.61 B	22									
					4	4 7 9	6.23 B	20				30					
					5	4 5 9	4.02 B	20									
	634.0	Dense to very dense, brown GRAVELLY SAND, some weathered dolostone fragments; damp --RDR 4--	15		6	4 5 17	5.00 B	22				35					
					7	16 26 20	NP	4									
					8	9	NP	5									
	628.7		20									40					

GENERAL NOTES

WATER LEVEL DATA

Begin Drilling **08-08-2017** Complete Drilling **08-08-2017**
 Drilling Contractor **Wang Testing Services** Drill Rig **B57 TMR [100%]**
 Driller **N&N** Logger **A. Tomaras** Checked by **C. Marin**
 Drilling Method **2.25 HSA; backfilled upon completion**

While Drilling ∇ **DRY**
 At Completion of Drilling ∇ **DRY**
 Time After Drilling **NA**
 Depth to Water ∇ **NA**

The stratification lines represent the approximate boundary between soil types; the actual transition may be gradual.

WANGENG 4910301.GPJ WANGENG.GDT 1/25/18



wangeng@wangeng.com
 1145 N Main Street
 Lombard, IL 60148
 Telephone: 630 953-9928
 Fax: 630 953-9938

BORING LOG RWB-17

WEI Job No.: 491-03-01

Client **Accurate Group, Inc.**
 Project **East Avenue from Joliet Road to 55th Street**
 Location **Cook County, IL**

Datum: NAVD 88
 Elevation: 649.15 ft
 North: 1866246.86 ft
 East: 1113663.78 ft
 Station: 229+77.43
 Offset: 16.20 RT

Profile	Elevation (ft)	SOIL AND ROCK DESCRIPTION	Depth (ft)	Sample Type recovery	Sample No.	SPT Values (blw/6 in)	Qu (tsf)	Moisture Content (%)	Profile	Elevation (ft)	SOIL AND ROCK DESCRIPTION	Depth (ft)	Sample Type recovery	Sample No.	SPT Values (blw/6 in)	Qu (tsf)	Moisture Content (%)
	648.0	13-inch thick ASPHALT --PAVEMENT--															
	647.7	Medium stiff (0.75P), black and brown CLAY LOAM, trace gravel; damp			1	4 2 4	1.75 P	14			poor rock mass quality, highly weathered DOLOSTONE, 1.3-inch spacing of joints, horizontal and oblique joints, less than 0.05 to greater than 0.2-inch joint opening, less than 0.2-inch infill, slightly rough to rough and hard joint walls.						
	646.1	Stiff, black SILTY CLAY, trace roots; damp									--FILL--						
		Stiff to hard, brown to gray CLAY to SILTY CLAY, trace gravel; moist	5		2	2 2 4	2.46 B	24			--BURIED TOPSOIL--			9			
											--RDR 2--						
					3	2 5 5	3.20 B	21									
					4	3 4 9	2.79 B	19		620.1	Boring terminated at 29.00 ft						
			10														
					5	3 5 6	4.10 B	25									
					6	2 3 5	1.64 B	21									
		--hard drilling from 15.75 feet--	15														
	633.4	Dense, brown GRAVELLY SAND, some weathered dolostone fragments; damp			7	25 21 24	NP	3									
	630.6																
	630.1	--WEATHERED BEDROCK--			8	50/3	NP	4									
		Strong, light greyish yellow, very	20														

GENERAL NOTES

Begin Drilling **08-08-2017** Complete Drilling **08-08-2017**
 Drilling Contractor **Wang Testing Services** Drill Rig **B57 TMR [100%]**
 Driller **N&N** Logger **A. Tomaras** Checked by **C. Marin**
 Drilling Method **2.25 HSA; backfilled upon completion**

WATER LEVEL DATA

While Drilling ∇ **DRY**
 At Completion of Drilling ∇ **DRY**
 Time After Drilling **NA**
 Depth to Water ∇ **NA**

The stratification lines represent the approximate boundary between soil types; the actual transition may be gradual.

WANGENGINC 4910301.GPJ WANGENG.GDT 1/25/18



wangeng@wangeng.com
 1145 N Main Street
 Lombard, IL 60148
 Telephone: 630 953-9928
 Fax: 630 953-9938

BORING LOG RWB-18

WEI Job No.: 491-03-01

Client **Accurate Group, Inc.**
 Project **East Avenue from Joliet Road to 55th Street**
 Location **Cook County, IL**

Datum: NAVD 88
 Elevation: 649.50 ft
 North: 1866321.74 ft
 East: 1113660.75 ft
 Station: 230+52.37
 Offset: 15.87 RT

Profile	Elevation (ft)	SOIL AND ROCK DESCRIPTION	Depth (ft)	Sample Type recovery	Sample No.	SPT Values (blw/6 in)	Qu (tsf)	Moisture Content (%)	Profile	Elevation (ft)	SOIL AND ROCK DESCRIPTION	Depth (ft)	Sample Type recovery	Sample No.	SPT Values (blw/6 in)	Qu (tsf)	Moisture Content (%)
	648.7	7-inch thick, ASPHALT --PAVEMENT-- Stiff to very stiff, black and brown SILTY CLAY to SILTY CLAY LOAM, trace gravel; moist --FILL-- --RDR 2--			1	3 2 3	1.64 B	22			--WEATHERED BEDROCK-- --RDR 4-- --hard drilling, 20 to 21 feet-- --cobbles--			9	21 19 50/4	NP	8
			5		2	1 2 2	2.13 B	22		626.5	--AUGER REFUSAL-- Boring terminated at 23.00 ft	25					
					3	2 3 3	2.62 B	20									
	641.5	Very stiff to hard, brown and gray SILTY CLAY to SILTY CLAY LOAM, trace gravel; moist --RDR 2 to 3--	10		4	5 7 9	4.51 B	20				30					
					5	4 6 9	4.18 B	20									
			15		6	9 5 7	3.28 B	24				35					
	632.5	Medium dense, brown, coarse SAND; moist			7	2 13 14	3.44 B	23									
	631.5	--RDR 2-- Dense to very dense, brown and gray SANDY GRAVEL, some highly weathered dolostone fragments; moist	20		8	12 17 19	NP	4				40					

GENERAL NOTES

Begin Drilling **06-30-2017** Complete Drilling **06-30-2017**
 Drilling Contractor **Wang Testing Services** Drill Rig **D50 ATV [88%]**
 Driller **K&K** Logger **R. KC** Checked by **C. Marin**
 Drilling Method **3.25.HSA; backfilled upon completion**

WATER LEVEL DATA

While Drilling ∇ **DRY**
 At Completion of Drilling ∇ **DRY**
 Time After Drilling **NA**
 Depth to Water ∇ **NA**

The stratification lines represent the approximate boundary between soil types; the actual transition may be gradual.

WANGENG 4910301.GPJ WANGENG.GDT 1/25/18



wangeng@wangeng.com
 1145 N Main Street
 Lombard, IL 60148
 Telephone: 630 953-9928
 Fax: 630 953-9938

BORING LOG RWB-19

WEI Job No.: 491-03-01

Client **Accurate Group, Inc.**
 Project **East Avenue from Joliet Road to 55th Street**
 Location **Cook County, IL**

Datum: NAVD 88
 Elevation: 649.92 ft
 North: 1866396.33 ft
 East: 1113658.68 ft
 Station: 231+26.98
 Offset: 16.49 RT

Profile	Elevation (ft)	SOIL AND ROCK DESCRIPTION	Depth (ft)	Sample Type recovery	Sample No.	SPT Values (blw/6 in)	Qu (tsf)	Moisture Content (%)	Profile	Elevation (ft)	SOIL AND ROCK DESCRIPTION	Depth (ft)	Sample Type recovery	Sample No.	SPT Values (blw/6 in)	Qu (tsf)	Moisture Content (%)	
	649.2	9-inch thick, black ASPHALT								629.4	Very dense, gray SANDY GRAVEL, some weathered dolostone fragments; damp							
		Stiff to hard, black, brown and gray SILTY CLAY to CLAY LOAM, trace gravel; moist			1	7 2 4	1.97 B	19			--WEATHERED BEDROCK--			9	12 29 32		NP	3
		--FILL-- --RDR 2--									--RDR 4--							
		--L _L (%)=43, P _L (%)=21-- --%Gravel=2.4-- --%Sand=18.7-- --%Silt=49.2-- --%Clay=29.6-- --A-7-6 (17)--			2	3 5 5	1.89 B	22			--AUGER REFUSAL--			10	50/5"			NR
										625.4	Boring terminated at 24.50 ft	25						
					3	3 4 6	4.35 B	22										
	641.9	Hard, brown and gray SILTY CLAY, trace gravel; moist			4	3 5 9	4.51 B	22										
		--RDR 2--																
					5	3 6 9	4.26 B	20										
	636.9	Very stiff, brown to dark brown CLAY to SILTY CLAY; moist			6	5 4 8	3.53 B	21										
		--RDR 3--																
	633.6	Loose, brown SAND; wet			7	3 3 5	4.18 B	21										
	633.1	Hard, black and brown CLAY; moist																
	631.9	Dense, gray SANDY GRAVEL, some highly weathered dolostone fragments; moist			8	4 4 26	NP	4										
		--RDR 3-- --some cobbles--																

GENERAL NOTES

WATER LEVEL DATA

Begin Drilling **06-30-2017** Complete Drilling **06-30-2017**
 Drilling Contractor **Wang Testing Services** Drill Rig **D50 ATV [88%]**
 Driller **K&K** Logger **R. KC** Checked by **C. Marin**
 Drilling Method **3.25 HSA; backfilled upon completion**

While Drilling ∇ **DRY**
 At Completion of Drilling ∇ **DRY**
 Time After Drilling **NA**
 Depth to Water ∇ **NA**

The stratification lines represent the approximate boundary between soil types; the actual transition may be gradual.

WANGENG 4910301.GPJ WANGENG.GDT 1/25/18



wangeng@wangeng.com
 1145 N Main Street
 Lombard, IL 60148
 Telephone: 630 953-9928
 Fax: 630 953-9938

BORING LOG RWB-20

WEI Job No.: 491-03-01

Client **Accurate Group, Inc.**
 Project **East Avenue from Joliet Road to 55th Street**
 Location **Cook County, IL**

Datum: NAVD 88
 Elevation: 650.21 ft
 North: 1866471.15 ft
 East: 1113655.08 ft
 Station: 232+01.89
 Offset: 15.57 RT

Profile	Elevation (ft)	SOIL AND ROCK DESCRIPTION	Depth (ft)	Sample Type recovery	Sample No.	SPT Values (blw/6 in)	Qu (tsf)	Moisture Content (%)	Profile	Elevation (ft)	SOIL AND ROCK DESCRIPTION	Depth (ft)	Sample Type recovery	Sample No.	SPT Values (blw/6 in)	Qu (tsf)	Moisture Content (%)
	649.5	9-inch thick, ASPHALT --PAVEMENT--									--cobbles-- --RDR 4--						
		Stiff to hard, brown to light brown SILTY CLAY to CLAY LOAM, trace gravel; moist --FILL-- --RDR 2--			1	4 3 5	1.23 B	17						9	20 20 20	NP	4
					2	3 3 6	4.43 S	21		627.2	Very dense, gray SANDY GRAVEL, some weathered dolostone fragments; damp --WEATHERED BEDROCK-- --RDR 4--25			10	52 52 28	NP	4
	644.7	Hard, light brown to brown SILTY CLAY LOAM, trace gravel; moist --RDR 2--			3	4 4 7	5.33 B	21			Boring terminated at 25.00 ft						
					4	4 5 8	4.59 B	21									
					5	4 5 8	4.10 B	20									
					6	3 7 9	4.76 B	21									
	634.7	Very stiff, dark brown CLAY to SILTY CLAY; moist --RDR 2--			7	4 6 8	2.54 B	21									
	632.2	Dense, brown and gray GRAVELLY SAND, some highly weathered dolostone fragments; damp			8	3 26 18	NP	4									

GENERAL NOTES

WATER LEVEL DATA

Begin Drilling **06-30-2017** Complete Drilling **06-30-2017**
 Drilling Contractor **Wang Testing Services** Drill Rig **D50 ATV [88%]**
 Driller **K&K** Logger **R. KC** Checked by **C. Marin**
 Drilling Method **3.25 HSA; backfilled upon completion**

While Drilling ∇ **DRY**
 At Completion of Drilling ∇ **DRY**
 Time After Drilling **NA**
 Depth to Water ∇ **NA**

The stratification lines represent the approximate boundary between soil types; the actual transition may be gradual.

WANGENG 4910301.GPJ WANGENG.GDT 1/25/18



wangeng@wangeng.com
 1145 N Main Street
 Lombard, IL 60148
 Telephone: 630 953-9928
 Fax: 630 953-9938

BORING LOG RWB-21

WEI Job No.: 491-03-01

Client **Accurate Group, Inc.**
 Project **East Avenue from Joliet Road to 55th Street**
 Location **Cook County, IL**

Datum: NAVD 88
 Elevation: 650.63 ft
 North: 1866547.53 ft
 East: 1113652.26 ft
 Station: 232+78.31
 Offset: 15.51 RT

Profile	Elevation (ft)	SOIL AND ROCK DESCRIPTION	Depth (ft)	Sample Type recovery	Sample No.	SPT Values (blw/6 in)	Qu (tsf)	Moisture Content (%)	Profile	Elevation (ft)	SOIL AND ROCK DESCRIPTION	Depth (ft)	Sample Type recovery	Sample No.	SPT Values (blw/6 in)	Qu (tsf)	Moisture Content (%)
	650.0	8-inch thick, ASPHALT --PAVEMENT-- Very stiff to hard, black and brown CLAY LOAM, trace gravel; moist	0		1	5 2 3	4.51 B	15		630.1	--RDR 4-- Very dense, gray SANDY GRAVEL, some weathered dolostone fragments; moist	0		9	32 50/3	NP	4
		--FILL-- --RDR 2-- --trace organic matter--	5		2	4 6 7	2.87 B	19		628.4	--WEATHERED BEDROCK-- --RDR 4-- --AUGER REFUSAL-- Boring terminated at 22.25 ft	5					
			10		3	4 6 8	5.17 B	20									
	642.6	Very stiff to hard, brown and gray SILTY CLAY to SILTY CLAY LOAM, trace gravel; moist	10		4	4 6 9	4.84 B	19									
		--RDR 2--	15		5	4 5 7	3.69 B	21									
	637.6	Very stiff, brown to dark brown CLAY to SILTY CLAY; moist	15		6	4 4 6	3.53 B	20									
		--RDR 3--	20		7	4 6	3.20 B	18									
		--hard drilling from 17.5 feet-- --cobbles--	20		8	13 24 33	NP	4									
	632.6	Very dense, brown and gray SANDY GRAVEL, some highly weathered dolostone fragments; moist	20														

GENERAL NOTES

WATER LEVEL DATA

Begin Drilling **06-30-2017** Complete Drilling **06-30-2017**
 Drilling Contractor **Wang Testing Services** Drill Rig **D50 ATV [88%]**
 Driller **K&K** Logger **R. KC** Checked by **C. Marin**
 Drilling Method **2.25 HSA; backfilled upon completion**

While Drilling ∇ **DRY**
 At Completion of Drilling ∇ **DRY**
 Time After Drilling **NA**
 Depth to Water ∇ **NA**

The stratification lines represent the approximate boundary between soil types; the actual transition may be gradual.

WANGENG 4910301.GPJ WANGENG.GDT 1/25/18



wangeng@wangeng.com
 1145 N Main Street
 Lombard, IL 60148
 Telephone: 630 953-9928
 Fax: 630 953-9938

BORING LOG RWB-22

WEI Job No.: 491-03-01

Client **Accurate Group, Inc.**
 Project **East Avenue from Joliet Road to 55th Street**
 Location **Cook County, IL**

Datum: NAVD 88
 Elevation: 650.94 ft
 North: 1866645.24 ft
 East: 1113741.69 ft
 Station: 313+19.79
 Offset: 24.96 RT

Profile	Elevation (ft)	SOIL AND ROCK DESCRIPTION	Depth (ft)	Sample Type recovery	Sample No.	SPT Values (blw/6 in)	Qu (tsf)	Moisture Content (%)	Profile	Elevation (ft)	SOIL AND ROCK DESCRIPTION	Depth (ft)	Sample Type recovery	Sample No.	SPT Values (blw/6 in)	Qu (tsf)	Moisture Content (%)	
	649.6	4-inch thick ASPHALT over 12-inch thick CONCRETE --PAVEMENT--									--RDR 3 to 4--							
	649.4	White GRAVELLY SAND; dry --BASE COURSE--			1	3 3 4	2.75 P	23						9	13 15 15		NP	5
		Medium stiff to very stiff, brown and gray SILTY CLAY to CLAY LOAM, trace gravel; moist --FILL-- --RDR 2--	5		2	3 2 2	0.82 B	25			--some highly weathered dolostone fragments--			10	18 7 11		NP	6
					3	1 1 2	0.98 B	23			Boring terminated at 25.00 ft							
	642.9	Loose, brown GRAVELLY SAND; dry			4	6 2 4	NP	6										
	641.2	Soft to medium stiff, brown and black SILTY CLAY, trace gravel; moist --RDR 3--	10		5	6 4 2	NA											
					6	2 1 3	0.49 B	21										
	634.6	White GRAVELLY SAND; dry			7	3 3 3	0.57 B	25										
	634.2	Very stiff (2.0P), gray SILTY CLAY, trace gravel; damp																
	632.2	Medium dense to dense, brown GRAVELLY SAND to SANDY GRAVEL; damp	20		8	6 7 30	NP	6										

GENERAL NOTES

WATER LEVEL DATA

Begin Drilling **08-10-2017** Complete Drilling **08-10-2017**
 Drilling Contractor **Wang Testing Services** Drill Rig **B57 TMR [100%]**
 Driller **N&N** Logger **A. Tomaras** Checked by **C. Marin**
 Drilling Method **2.25 HSA; backfilled upon completion**

While Drilling ∇ **DRY**
 At Completion of Drilling ∇ **DRY**
 Time After Drilling **NA**
 Depth to Water ∇ **NA**

The stratification lines represent the approximate boundary between soil types; the actual transition may be gradual.

WANGENG 4910301.GPJ WANGENG.GDT 1/25/18



wangeng@wangeng.com
 1145 N Main Street
 Lombard, IL 60148
 Telephone: 630 953-9928
 Fax: 630 953-9938

BORING LOG RW-01

WEI Job No.: 555-15-02

Client: **IDOT District One**
 Project: **FAU Route 2719 (55th Street)**
 Location: **Cook County, Illinois**

Datum: NGVD
 Elevation: 649.94 ft
 North: 1866416.37 ft
 East: 1113657.50 ft
 Station: 231+47.05
 Offset: 16.02 RT

Profile	Elevation (ft)	SOIL AND ROCK DESCRIPTION	Depth (ft)	Sample Type recovery	Sample No.	SPT Values (blw/6 in)	Qu (tsf)	Moisture Content (%)	Profile	Elevation (ft)	SOIL AND ROCK DESCRIPTION	Depth (ft)	Sample Type recovery	Sample No.	SPT Values (blw/6 in)	Qu (tsf)	Moisture Content (%)
	649.0	11-inch thick, ASPHALT --PAVEMENT--								624.4	Boring terminated at 22.50 ft						
	646.9	Loose, black SANDY LOAM, little gravel			1	3 2 4	NP	6									
	636.9	Medium stiff to very stiff, black, brown, and gray SILTY CLAY to SILTY CLAY LOAM, trace gravel --FILL--	5		2	2 2 2	2.25 P	18				30					
					3	2 3 5	2.44 B	22									
			10		4	2 4 6	0.98 B	22				35					
					5	3 3 4	2.30 B	18									
	636.9	Stiff, gray SILTY CLAY, trace gravel --L _L (%)=42, P _L (%)=18-- --%Gravel=1.1-- --%Sand=7.4-- --%Silt=50.3-- --%Clay=41.2-- --A-7-6 (23)--			6	3 4 7	1.80 B	21				40					
					7	3 3 6	1.97 B	20									
	631.4	Weathered DOLOSTONE fragments --WEATHERED BEDROCK-- --RECOVERY=1%-- --RQD=0%--	20		1							45					
												50					

GENERAL NOTES

Begin Drilling **11-15-2012** Complete Drilling **11-15-2012**
 Drilling Contractor **Wang Testing Services** Drill Rig **B-57 TMR**
 Driller **R&J** Logger **A. Happel** Checked by **C. Marin**
 Drilling Method **3.25-inch IDA HSA, boring backfilled with lean grout upon completion**

WATER LEVEL DATA

While Drilling **DRY**
 At Completion of Drilling **DRY**
 Time After Drilling **NA**
 Depth to Water **NA**

The stratification lines represent the approximate boundary between soil types; the actual transition may be gradual.

WANGENGINC 5551502.GPJ WANGENG.GDT 12/10/12



wangeng@wangeng.com
 1145 N Main Street
 Lombard, IL 60148
 Telephone: 630 953-9928
 Fax: 630 953-9938

BORING LOG RW-02

WEI Job No.: 555-15-02

Client: **IDOT District One**
 Project: **FAU Route 2719 (55th Street)**
 Location: **Cook County, Illinois**

Datum: NGVD
 Elevation: 649.78 ft
 North: 1866523.22 ft
 East: 1113654.82 ft
 Station: 232+53.93
 Offset: 17.19 RT

Profile	Elevation (ft)	SOIL AND ROCK DESCRIPTION	Depth (ft)	Sample Type recovery	Sample No.	SPT Values (blw/6 in)	Qu (tsf)	Moisture Content (%)	Profile	Elevation (ft)	SOIL AND ROCK DESCRIPTION	Depth (ft)	Sample Type recovery	Sample No.	SPT Values (blw/6 in)	Qu (tsf)	Moisture Content (%)
	648.9	11-inch thick, ASPHALT --PAVEMENT-- Very stiff to hard, brown and gray SILTY CLAY LOAM, trace gravel --FILL--	0-1		1	2 2 3	2.50 P	10		649.8	slightly weathered horizontal shale partings, vuggy DOLOSTONE --RECOVERY=100%-- --RQD=64%-- Qu = 9,590 psi at 27.25 feet	0-1		1			
			5		2	3 4 7	3.44 B	20				30					
			10		3	3 6 6	5.58 B	24				35					
	639.3	Very stiff, gray SILTY CLAY, trace gravel	10		4	2 4 8	4.35 B	21		615.8	Boring terminated at 34.00 ft	35					
			15		5	3 6 6	3.85 B	24				40					
	632.5	Very dense, gray and white SANDY GRAVEL, some weathered DOLOSTONE fragments --WEATHERED BEDROCK--	20		6	3 5 6	3.36 B	21				45					
			25		7	3 6 4	3.69 B	21				50					
	625.8	Strong, light gray, fresh, fair rock quality, horizontally bedded,	25		8	16 27 27	NP										
					9	22 50/5	NP										
						Co											

GENERAL NOTES

WATER LEVEL DATA

Begin Drilling **11-15-2012** Complete Drilling **11-15-2012**
 Drilling Contractor **Wang Testing Services** Drill Rig **B-57 TMR**
 Driller **R&J** Logger **A. Happel** Checked by **C. Marin**
 Drilling Method **3.25-inch IDA HSA, boring backfilled with lean grout upon completion**

While Drilling **DRY**
 At Completion of Drilling **DRY**
 Time After Drilling **NA**
 Depth to Water **NA**

The stratification lines represent the approximate boundary between soil types; the actual transition may be gradual.

WANGENGINC 5551502.GPJ WANGENG.GDT 12/10/12



wangeng@wangeng.com
 1145 N Main Street
 Lombard, IL 60148
 Telephone: 630 953-9928
 Fax: 630 953-9938

BORING LOG RW-04

WEI Job No.: 555-15-02

Client: **IDOT District One**
 Project: **FAU Route 2719 (55th Street)**
 Location: **Cook County, Illinois**

Datum: NGVD
 Elevation: 651.34 ft
 North: 1866645.25 ft
 East: 1113796.95 ft
 Station: 313+75.01
 Offset: 26.98 RT

Profile	Elevation (ft)	SOIL AND ROCK DESCRIPTION	Depth (ft)	Sample Type recovery	Sample No.	SPT Values (blw/6 in)	Qu (tsf)	Moisture Content (%)	Profile	Elevation (ft)	SOIL AND ROCK DESCRIPTION	Depth (ft)	Sample Type recovery	Sample No.	SPT Values (blw/6 in)	Qu (tsf)	Moisture Content (%)
	651.13	13-inch thick, ASPHALT --PAVEMENT--															
	649.8	CRUSHED STONE --BASE COURSE--			1	4 7 3	NP	23									
		Stiff to very stiff, brown and gray SILTY CLAY to SILTY CLAY LOAM, trace gravel															
		--FILL--	5		2	2 2 4	2.05 B	17									
		--L _L (%)=48, P _L (%)=19-- --%Gravel=0.6-- --%Sand=6.0-- --%Silt=50.7-- --%Clay=42.7-- --A-7-6 (29)--			3	2 2 3	1.23 S	21									
					4	3 5 8	3.69 B	23									
	641.3		10														
	640.8	SAND															
		Stiff to very stiff, gray SILTY CLAY, trace gravel			5	3 4 7	3.36 B	17									
					6	3 3 6	2.21 B	19									
			15														
					7	3 5 7	3.36 B	20									
					8	17 19 15	NP	5									
	632.3	Dense, gray and white WEATHERED BEDROCK --WEATHERED BEDROCK--	20														
	631.3																
		Boring terminated at 20.00 ft															

GENERAL NOTES

WATER LEVEL DATA

Begin Drilling **11-15-2012** Complete Drilling **11-15-2012**
 Drilling Contractor **Wang Testing Services** Drill Rig **B-57 TMR**
 Driller **R&J** Logger **A. Happel** Checked by **C. Marin**
 Drilling Method **3.25-inch IDA HSA, boring backfilled with lean grout upon completion**

While Drilling **10.00 ft**
 At Completion of Drilling **NA**
 Time After Drilling **NA**
 Depth to Water **NA**

The stratification lines represent the approximate boundary between soil types; the actual transition may be gradual.

APPENDIX B

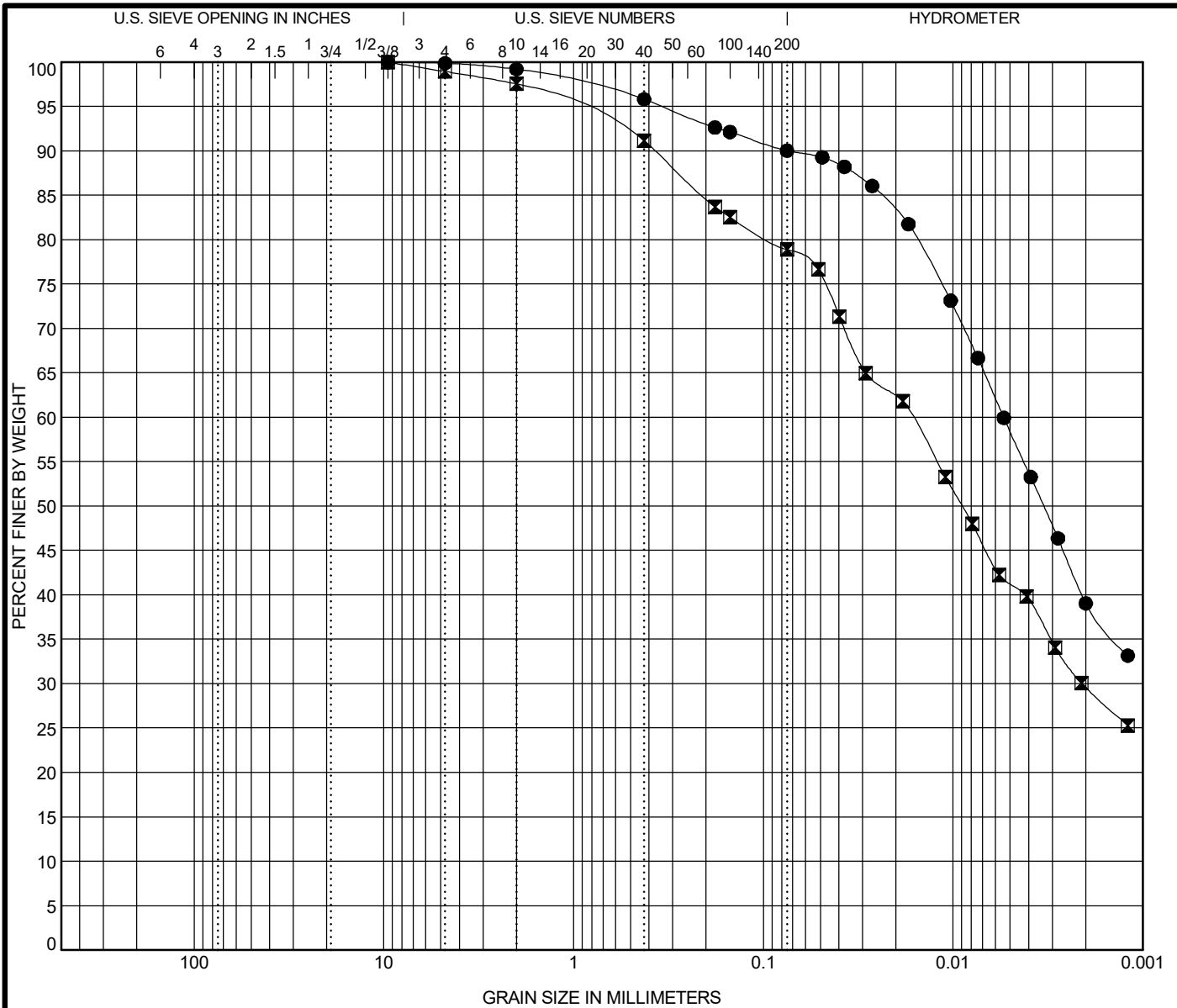

COBBLES	GRAVEL	SAND		SILT AND CLAY
		coarse	fine	

Specimen Identification		IDH Classification				LL	PL	PI	Cc	Cu
●	RWB-05#3 6.0 ft	Silty Clay				39	21	18		
☒	RWB-19#2 3.5 ft	Silty Clay				43	21	22		

Specimen Identification		D100	D60	D30	D10	%Gravel	%Sand	%Silt	%Clay
●	RWB-05#3 6.0 ft	9.5	0.005			0.8	9.2	51.0	39.0
☒	RWB-19#2 3.5 ft	9.5	0.017	0.002		2.4	18.7	49.2	29.6



Wang Engineering, Inc.
 1145 N. Main Street
 Lombard/IL/60148
 Telephone: 6309539928
 Fax: 6309539938

GRAIN SIZE DISTRIBUTION
 Project: East Avenue from Joliet Road to 55th Street
 Location: Cook County, IL
 Number: 491-03-01

WEI GRAIN SIZE IDH 4910301.GPJ US LAB.GDT 1/11/18



Unconfined Compressive Strength of Intact Rock Core Specimens

Project: East Avenue

Client: Accurate Group

WEI Job No.: 491-03-01

Note: The specimens were sulphur capped for a more uniform break

Field Sample ID	Lab Specimen ID	Depth (ft)	Location	Sample Description	Length(in)		Diameter (in)	Total Load (lbs)	Total Pressure (psi)	Fracture Type*	Break Date	Tested By	Area (in ²)
					Before Capping	After Capping							
RWB-13 RUN 1	4189	22.0			3.59	3.75	2.04	18040	5520	3	9/5/17	AM	3.27
RWB-17 RUN 1	4190	24.5			3.94	4.07	2.04	19620	6000	3	9/5/17	AM	3.27

*** Fracture Types:**

- Type 1 - Reasonably well-formed cones on both ends, less than 1 in. [25 mm] of cracking through caps;
- Type 2 - Well-formed cone on one end, vertical cracks running through caps, no well defined cone on other end;
- Type 3 - Columnar vertical cracking through both ends, no well-formed cones;
- Type 4 - Diagonal fracture with no cracking through ends; tap with hammer to distinguish from Type 1;
- Type 5 - Side fractures at top or bottom (occur commonly with unbonded caps);
- Type 6 - Similar to Type 5 but end of cylinder is pointed.

Prepared by: *Asif* 9/6/17

Checked by: *AL* 9/29/17

APPENDIX C

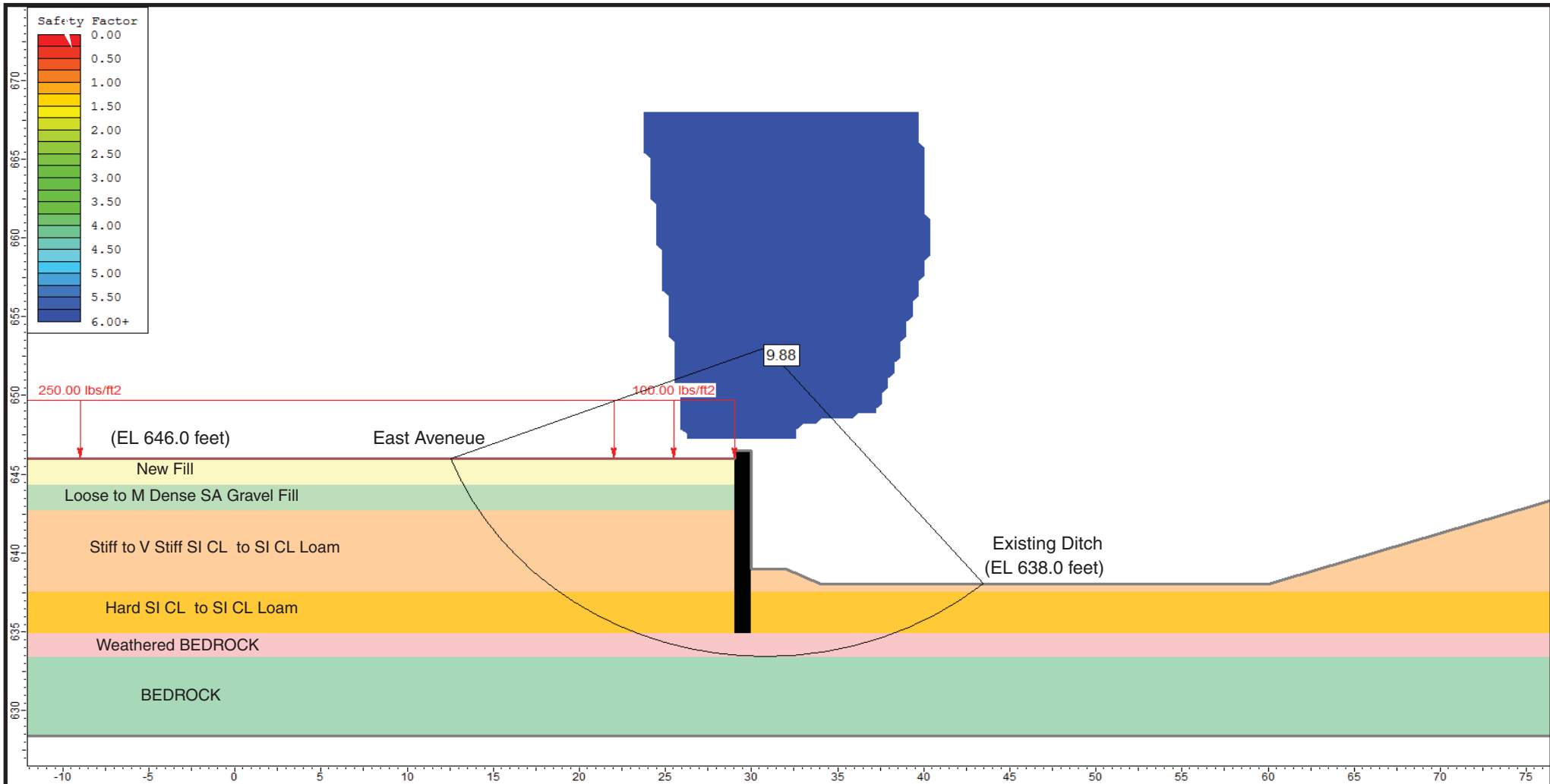

Undrained Analysis at Sta. 220+50, Ref Borings: RWB-04 and RWB-05

Layer ID	Description	Total Unit Weight (pcf)	Undrained Cohesion (psf)	Undrained Friction Angle (degrees)
1	New Fill	120	0	30
2	Loose to M Dense GRAVELLY SAND Fill	120	0	30
3	Stiff to V Stiff SI CL to SI CL Loam	120	2000	0
4	Hard SI CL to SI CL Loam	125	5000	0
5	V Dense Weathered BEDROCK	130	0	37
6	BEDROCK			

GLOBAL STABILITY: EAST AVENUE FROM JOLIET ROAD TO 55 TH STREET, RETAINING WALL, SN 016-Z022, COOK COUNTY, ILLINOIS

SCALE: GRAPHICAL APPENDIX C-1 DRAWN BY: NSB
CHECKED BY: AAK



1145 N. Main Street
Lombard, IL 60148
www.wangeng.com

FOR ACCURATE GROUP, INC. 491-03-01

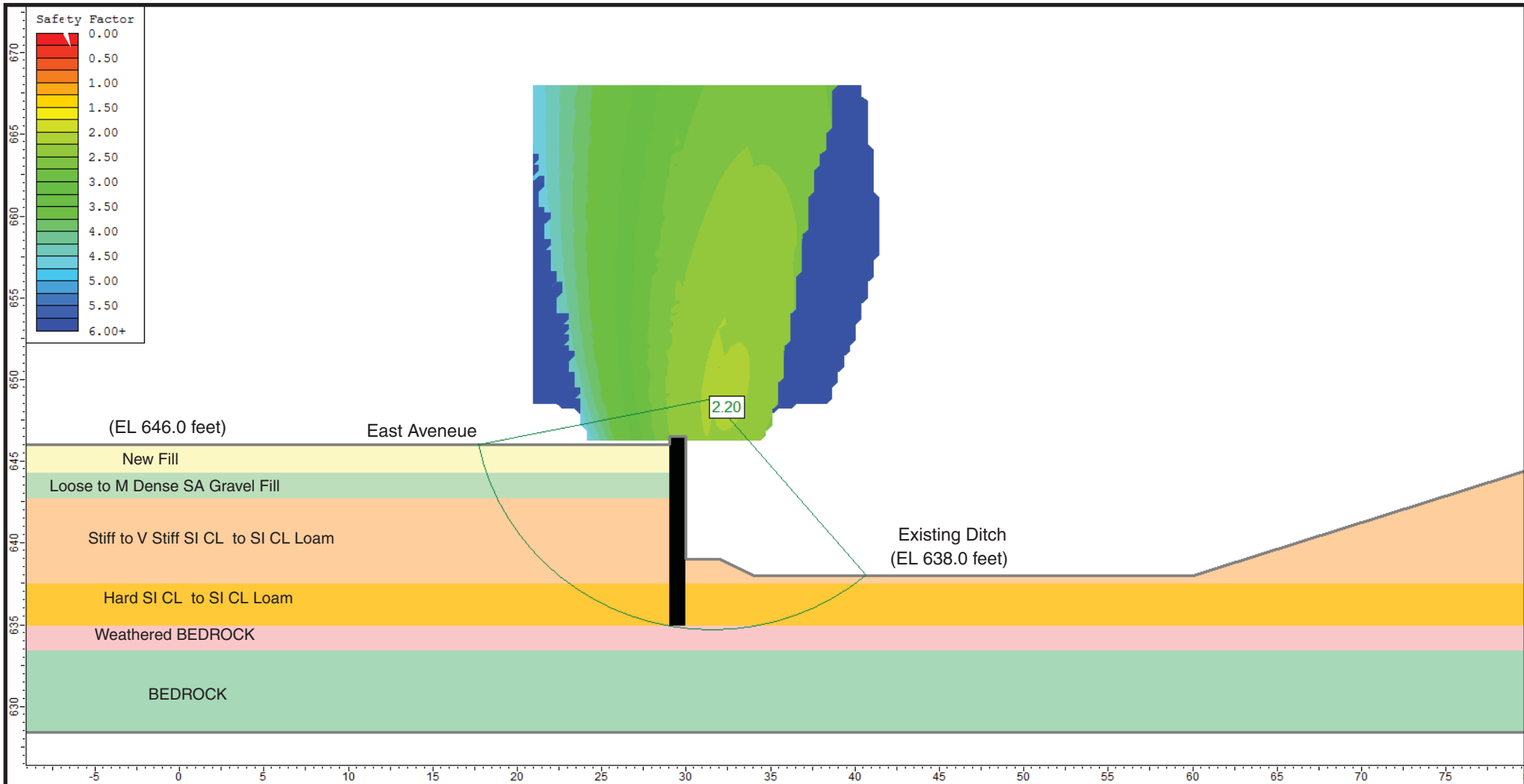

Drained Analysis at Sta. 220+50, Ref Borings: RWB-04 and RWB-05

Layer ID	Description	Total Unit Weight (pcf)	Drained Cohesion (psf)	Drained Friction Angle (degrees)
1	New Fill	120	0	30
2	Loose to M Dense GRAVELLY SAND Fill	120	0	30
3	Stiff to V Stiff SI CL to SI CL Loam	120	100	30
4	Hard SI CL to SI CL Loam	125	100	30
5	V Dense Weathered BEDROCK	130	0	37
6	BEDROCK			

GLOBAL STABILITY: EAST AVENUE FROM JOLIET ROAD TO 55 TH STREET, RETAINING WALL, SN 016-Z022, COOK COUNTY, ILLINOIS

SCALE: GRAPHICAL APPENDIX C-2 DRAWN BY: NSB
CHECKED BY: AAK

 **Wang Engineering** 1145 N. Main Street
Lombard, IL 60148
www.wangeng.com

FOR ACCURATE GROUP, INC. 491-03-01

APPENDIX D

RUN #1
TOP



RUN #1
BOTTOM

Boring RWB-01
RUN #1, 12.0 to 22.0 FEET
RECOVERY = 100%
RQD = 0%

BEDROCK CORE: EAST AVENUE FROM JOLIET ROAD TO 55TH STREET, RETAINING WALL, SN 016-Z022, COOK COUNTY, ILLINOIS		
SCALE : GRAPHIC	APPENDIX D-1	DRAWN BY: RKC CHECKED BY: A. Kurnia
		1145 N. Main Street Lombard, IL 60148 www.wangeng.com
FOR ACCURATE GROUP, INC.		491-03-01

RUN #1
TOP



0 3 6 9 12 inches

RUN #1
BOTTOM

Boring RWB-03
RUN #1, 10.0 to 20.0 FEET
RECOVERY = 100%
RQD = 0%

BEDROCK CORE: EAST AVENUE FROM JOLIET ROAD TO 55TH STREET, RETAINING WALL, SN 016-Z022, COOK COUNTY, ILLINOIS

SCALE : GRAPHIC APPENDIX D-2 DRAWN BY: RKC
CHECKED BY: A. Kurnia

 **Wang**
Engineering 1145 N. Main Street
Lombard, IL 60148
www.wangeng.com

FOR ACCURATE GROUP, INC. 491-03-01

RUN #1
TOP



0 3 6 9 12 inches

Boring RWB-05
RUN #1, 12.0 to 17.0 FEET
RECOVERY = 100%
RQD = 0%

BEDROCK CORE: EAST AVENUE FROM JOLIET ROAD TO 55TH STREET, RETAINING WALL, SN 016-Z022, COOK COUNTY, ILLINOIS

SCALE : GRAPHIC

APPENDIX D-3

DRAWN BY: RKC
CHECKED BY: A. Kurnia



1145 N. Main Street
Lombard, IL 60148
www.wangeng.com

FOR ACCURATE GROUP, INC.

491-03-01

RUN #1
TOP



0 3 6 9 12 inches

Boring RWB-07
RUN #1, 12.0 to 17.0 FEET
RECOVERY = 100%
RQD = 0%

BEDROCK CORE: EAST AVENUE FROM JOLIET ROAD TO 55TH STREET, RETAINING WALL, SN 016-Z022, COOK COUNTY, ILLINOIS

SCALE : GRAPHIC

APPENDIX D-4

DRAWN BY: RKC
CHECKED BY: A. Kurnia



1145 N. Main Street
Lombard, IL 60148
www.wangeng.com

FOR ACCURATE GROUP, INC.

491-03-01

RUN #1
TOP



0 3 6 9 12 inches

Boring RWB-09
RUN #1, 10.0 to 14.5 FEET
RECOVERY = 100%
RQD = 0%

BEDROCK CORE: EAST AVENUE FROM JOLIET ROAD TO 55TH STREET, RETAINING WALL SN 016-Z022, COOK COUNTY, ILLINOIS

SCALE : GRAPHIC

APPENDIX D-5

DRAWN BY: RKC
CHECKED BY: A. Kurnia



1145 N. Main Street
Lombard, IL 60148
www.wangeng.com

FOR ACCURATE GROUP, INC.

491-03-01

RUN #1
TOP



0 3 6 9 12 inches

RUN #1
BOTTOM

Boring RWB-11
RUN #1, 12.5 to 22.5 FEET
RECOVERY = 95%
RQD = 0%

BEDROCK CORE: EAST AVENUE FROM JOLIET ROAD TO 55TH STREET, RETAINING WALL SN 016-Z022, COOK COUNTY, ILLINOIS

SCALE : GRAPHIC

APPENDIX D-6

DRAWN BY: RKC
CHECKED BY: A. Kurnia



1145 N. Main Street
Lombard, IL 60148
www.wangeng.com

FOR ACCURATE GROUP, INC.

491-03-01

RUN #1
TOP



0 3 6 9 12 inches

RUN #1
BOTTOM

Boring RWB-13
RUN #1, 17.0 to 27.0 FEET
RECOVERY = 100%
RQD = 0%

BEDROCK CORE: EAST AVENUE FROM JOLIET ROAD TO 55TH STREET, RETAINING WALL SN 016-Z022, COOK COUNTY, ILLINOIS

SCALE : GRAPHIC

APPENDIX D-7

DRAWN BY: RKC
CHECKED BY: A. Kurnia



1145 N. Main Street
Lombard, IL 60148
www.wangeng.com

FOR ACCURATE GROUP, INC.

491-03-01

RUN #1
TOP



0 3 6 9 12 inches

RUN #1
BOTTOM

Boring RWB-17
RUN #1, 19.0 to 29.0 FEET
RECOVERY = 96%
RQD = 12%

BEDROCK CORE: EAST AVENUE FROM JOLIET ROAD TO 55TH STREET, RETAINING WALL SN 016-Z022, COOK COUNTY, ILLINOIS

SCALE : GRAPHIC

APPENDIX D-8

DRAWN BY: RKC
CHECKED BY: A. Kurnia



1145 N. Main Street
Lombard, IL 60148
www.wangeng.com

FOR ACCURATE GROUP, INC.

491-03-01



Boring RW-02:
Run #1, 24' to 34', RECOVERY=100%, RQD=64%

BEDROCK CORE: 55TH STREET AND EAST AVENUE McCOOK, IL, COOK COUNTY		
SCALE: GRAPHICAL	APPENDIX D-9	DRAWN BY: D. KOLPACK CHECKED BY: C. MARIN
 Wang Engineering		1145 N. Main Street Lombard, IL 60148 www.wangeng.com
FOR I.D.O.T.		555-15-02

APPENDIX E

Bench Mark: Chiseled Square in traffic signal mast arm concrete foundation on south side of foundation at NE corner of East Ave. and 55th St. Elev. = 651.55

Existing Structure: None

Traffic on East Ave. will be maintained utilizing staged construction.

* For elevations, see Table 1 on Sheet 5 of 6.

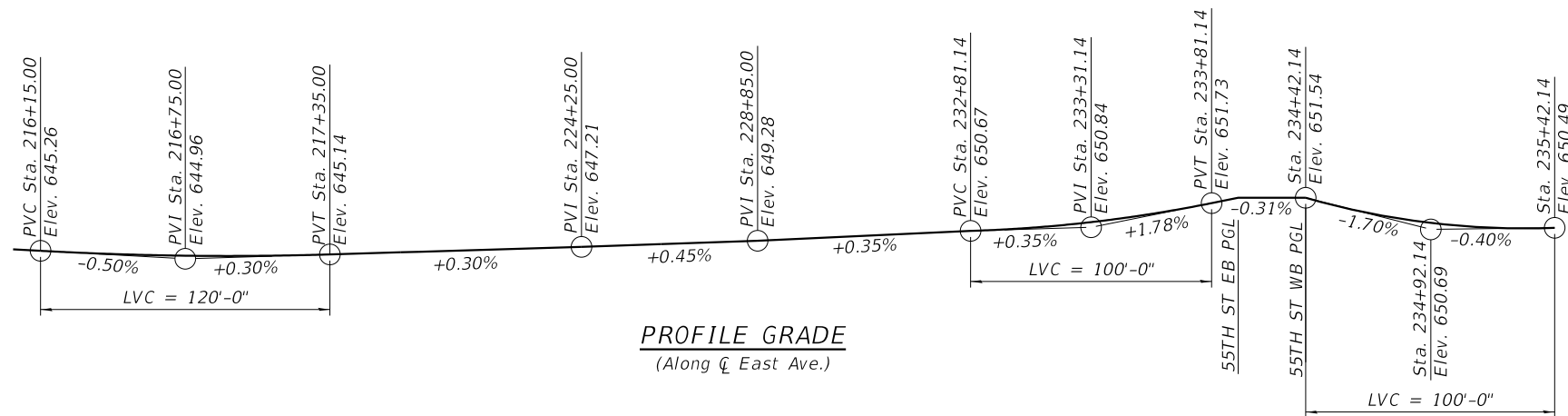

HIGHWAY CLASSIFICATION

F.A.U. Rte. 2719 (East Ave.)
 Functional Class: Collector
 ADT: 24,000 (2012); (2040) 25,000
 ADTT: 1,495 (2012); (2040) 1,557
 DHV: 660 (2040)
 Design Speed: 40 m.p.h.
 Posted Speed: 40 m.p.h.
 Two -Way Traffic
 Directional Distribution: 50:50

DESIGN SPECIFICATIONS

2017 AASHTO LRFD Bridge Design Specifications, 8th Edition

DESIGN STRESSES

FIELD UNITS
 f'c = 3,500 psi
 fy = 60,000 psi (Reinforcement)
 fy = 50,000 psi (M270 Grade 50)
 fb = 1,600 psi (Treated Timber Lagging)

LEGEND:

- Exist. Storm Sewer
- Prop. Storm Sewer
- Gas
- Water
- Aerial
- Exist. Sanitary Sewer
- Exist. Cable
- Soil Boring
- Exist. Manhole
- Exist. Catch Basin
- Prop. Manhole
- Prop. Catch Basin
- Prop. Inlet

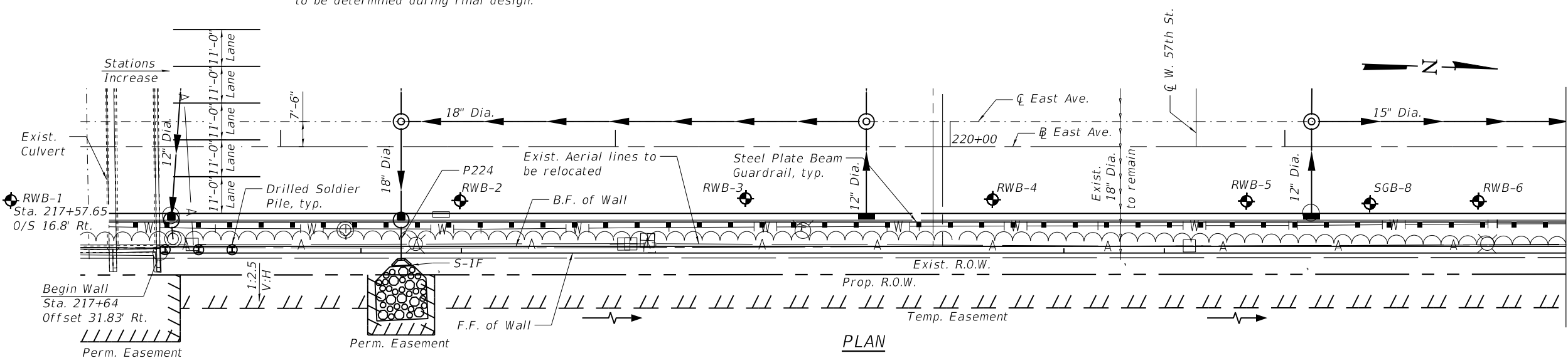
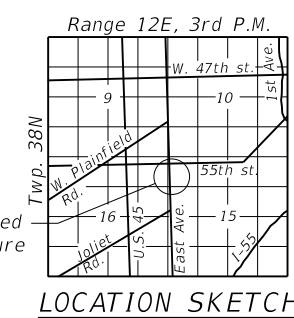
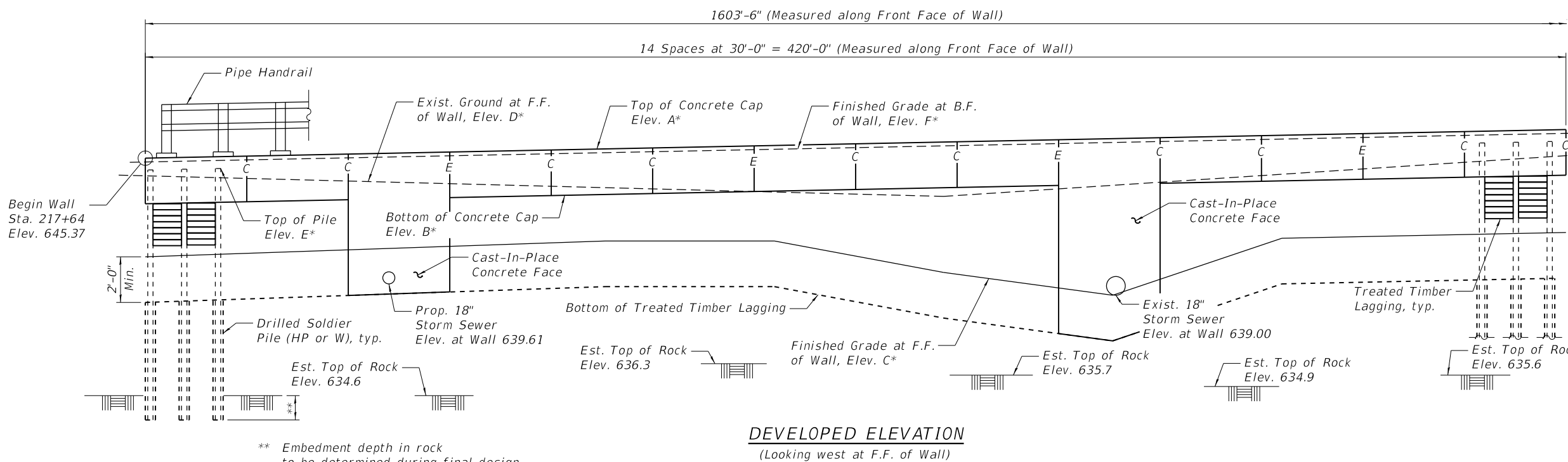

GENERAL PLAN
RETAINING WALL ALONG
F.A.U. RTE. 2719 (EAST AVENUE)
SECTION 0102N&T
COOK COUNTY
STATION 217+64 TO 233+49.50
STRUCTURE NO. 016-Z022

MODEL: Default
 FILE NAME: Q:\Engineering\Live\Projects\13031.IDOT East Ave\ADD\CADD Sheets\Structural\TS&L\10162022-62C25-001-GPE.dgn
 10/8/2018 7:39:20 AM



USER NAME = JENT	DESIGNED - SAT	REVISED -
PLOT SCALE = 36,000' / 1" = 300'	CHECKED - JMT	REVISED -
PLOT DATE = 10/8/2018	DRAWN - SAT	REVISED -
	CHECKED - SPS	REVISED -

STATE OF ILLINOIS
DEPARTMENT OF TRANSPORTATION

SHEET 1 OF 6 SHEETS

F.A.U. RTE. 2719	SECTION 0102N&T	COUNTY COOK	TOTAL SHEETS 1	SHEET NO. 6
CONTRACT NO. 62C25				
ILLINOIS FED. AID PROJECT				

NOTES:

1. Wall offsets are measured from the ϕ of East Avenue to the front face of the concrete cap.
2. C denotes Construction Joint.
3. E denotes Expansion Joint.
4. F.F. denotes Front Face.
5. B.F. denotes Back Face.
6. Soldier Pile sections, shaft diameter, spacing and tip elevation to be determined during final design.
7. Proposed drainage and lighting information shown is conceptual and will be determined during final design.
8. Existing Aerial lines are in conflict with retaining wall and shall be relocated.

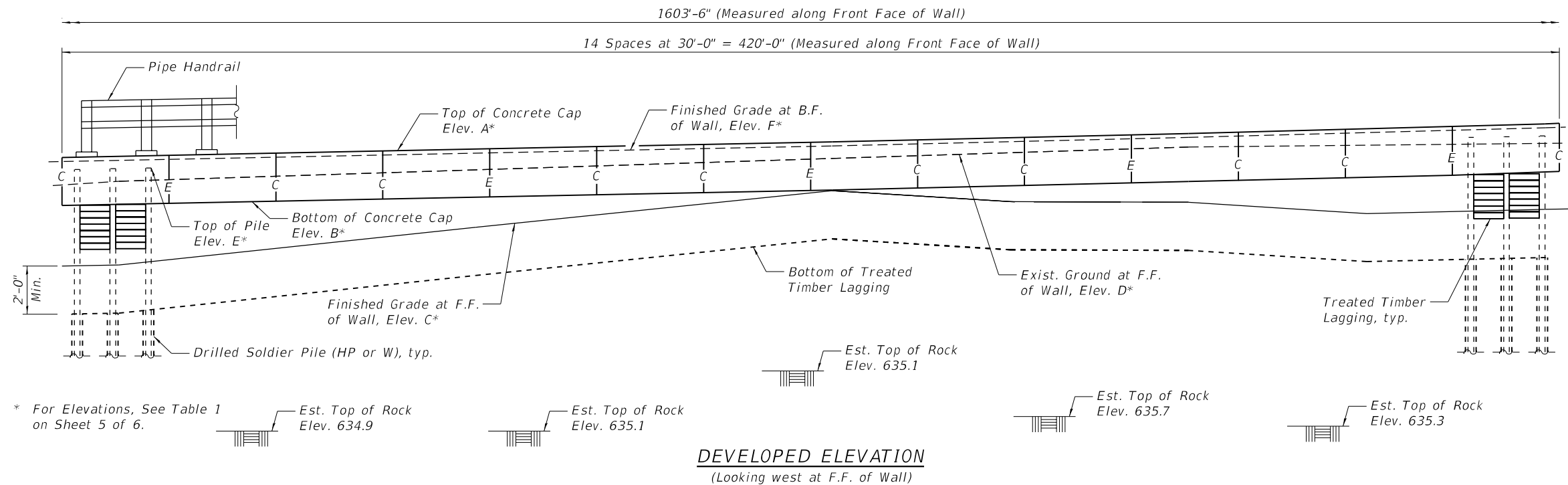

* For Elevations, See Table 1 on Sheet 5 of 6.

LEGEND:

- Exist. Storm Sewer
- Prop. Storm Sewer
- Gas
- Water
- Aerial
- Exist. Sanitary Sewer
- Exist. Cable
- Soil Boring
- Exist. Manhole
- Exist. Catch Basin
- Prop. Manhole
- Prop. Catch Basin
- Prop. Inlet

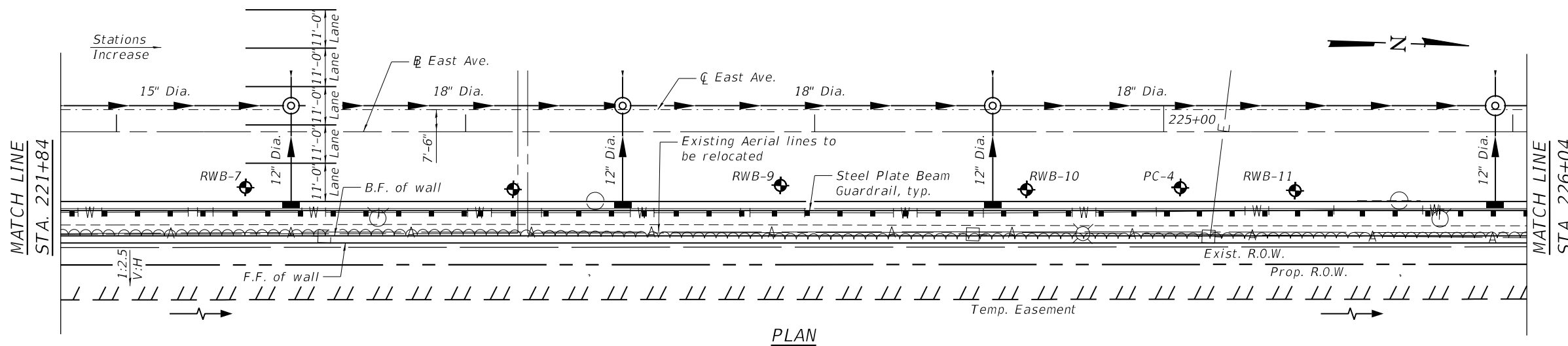

GENERAL PLAN
RETAINING WALL ALONG
F.A.U. RTE. 2719 (EAST AVENUE)
SECTION 0102N&T
COOK COUNTY
STATION 217+64 TO 233+49.50
STRUCTURE NO. 016-Z022

MODEL: Default
 FILE NAME: Q:\Engineering\Live\Projects\13031.IDOT East Ave\CADD\CADD Sheets\Structural\15&1016Z022-62C25-002-GPE.dgn
 10/5/2018 4:17:32 PM



USER NAME = johnn	DESIGNED - SAT	REVISED -
CHECKED - JMT	REVISIONS -	
PLOT SCALE = 36,0000' / in.	DRAWN - SAT	REVISED -
PLOT DATE = 10/5/2018	CHECKED - SPS	REVISED -

STATE OF ILLINOIS
DEPARTMENT OF TRANSPORTATION

SHEET 2 OF 6 SHEETS

F.A.U. RTE.	SECTION	COUNTY	TOTAL SHEETS	SHEET NO.
2719	0102N&T	COOK	2	6
CONTRACT NO. 62C25				
ILLINOIS FED. AID PROJECT				

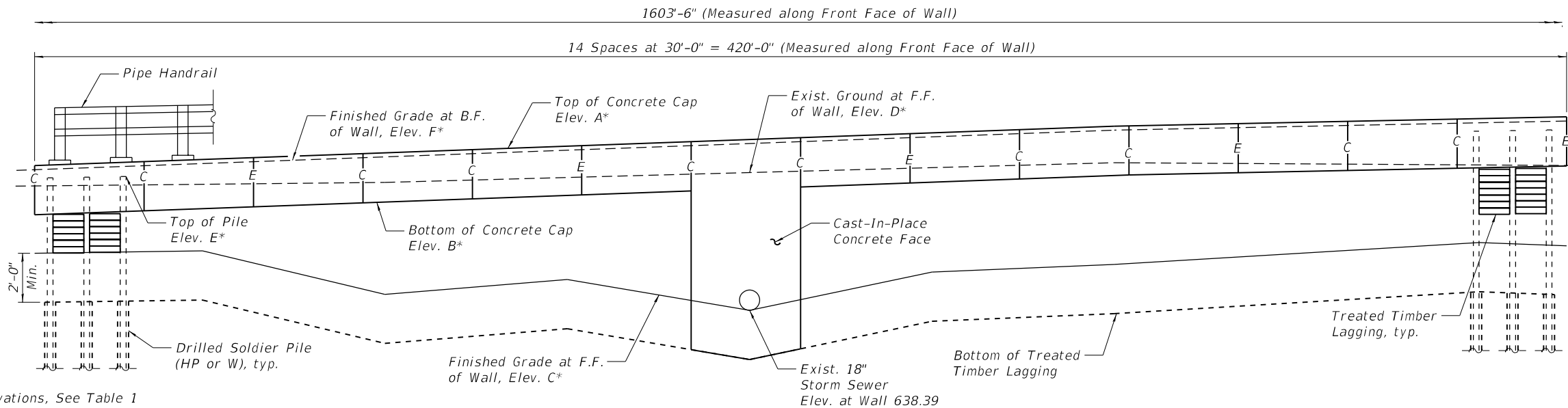

* For Elevations, See Table 1 on Sheet 5 of 6.



Note: Top of Rock Elevations are not drawn to scale.

LEGEND:

- Exist. Storm Sewer
- Prop. Storm Sewer
- Gas
- Water
- Aerial
- Exist. Sanitary Sewer
- Exist. Cable
- Soil Boring
- Exist. Manhole
- Exist. Catch Basin
- Prop. Manhole
- Prop. Catch Basin
- Prop. Inlet

DEVELOPED ELEVATION
(Looking west at F.F. of Wall)

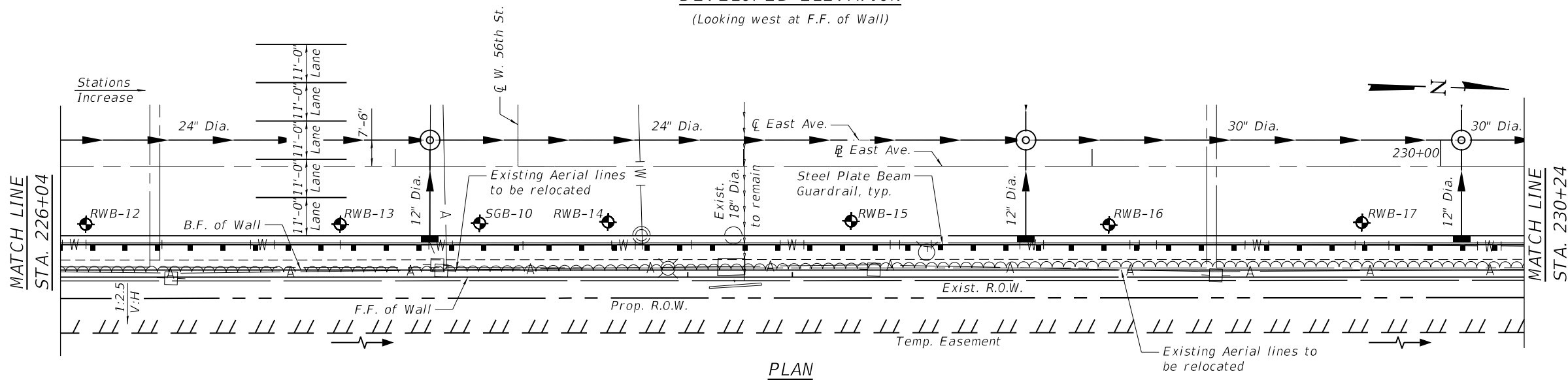

PLAN

GENERAL PLAN
RETAINING WALL ALONG
F.A.U. RTE. 2719 (EAST AVENUE)
SECTION 0102N&T
COOK COUNTY
STATION 217+64 TO 233+49.50
STRUCTURE NO. 016-Z022

MODEL: Default
FILE NAME: Q:\Engineering\Live\Projects\13031.IDOT East Ave\CADD\CADD Sheets\Structural\15&1016Z022-62C25-003-GPE.dgn



USER NAME = johnn	DESIGNED - SAT	REVISED -
CHECKED - JMT	REVISOR -	
PLOT SCALE = 36,0000' / in.	DRAWN - SAT	REVISED -
PLOT DATE = 10/5/2018	CHECKED - SPS	REVISED -

STATE OF ILLINOIS
DEPARTMENT OF TRANSPORTATION

SHEET 3 OF 6 SHEETS

F.A.U. RTE.	SECTION	COUNTY	TOTAL SHEETS	SHEET NO.
2719	0102N&T	COOK	3	6
CONTRACT NO. 62C25				
ILLINOIS FED. AID PROJECT				

TABLE 1 - WALL ELEVATIONS

Station	Offset	Elevation A	Elevation B	Elevation C	Elevation D	Elevation E	Elevation F
217+64.00	31.83' RT	645.37	643.79	640.69	644.10	644.87	645.21
217+94.00	31.83' RT	645.46	643.88	640.82	644.10	644.96	645.30
218+00.00	31.83' RT	645.48	643.90	640.84	644.10	644.98	645.31
218+24.00	31.83' RT	645.55	643.97	640.97	644.26	645.05	645.39
218+54.00	31.83' RT	645.64	644.06	641.13	644.45	645.14	645.48
218+84.00	31.83' RT	645.73	644.15	641.29	644.65	645.23	645.57
219+00.00	31.83' RT	645.78	644.20	641.38	644.75	645.28	645.61
219+14.00	31.83' RT	645.82	644.24	641.19	644.55	645.32	645.66
219+44.00	31.83' RT	645.91	644.33	640.77	644.13	645.41	645.75
219+74.00	31.83' RT	646.00	644.42	640.36	643.70	645.50	645.84
220+00.00	31.83' RT	646.08	644.50	640.00	643.33	645.58	645.91
220+04.00	31.83' RT	646.09	644.51	639.92	643.44	645.59	645.93
220+34.00	31.83' RT	646.18	644.60	639.32	644.26	645.68	646.02
220+50.00	31.83' RT	646.23	644.65	639.00	644.70	645.73	646.06
220+64.00	31.83' RT	646.27	644.69	639.70	644.74	645.77	646.11
220+94.00	31.83' RT	646.36	644.78	641.20	644.83	645.86	646.20
221+00.00	31.83' RT	646.38	644.80	641.50	644.85	645.88	646.21
221+24.00	31.83' RT	646.45	644.87	641.57	644.95	645.95	646.29
221+54.00	31.83' RT	646.54	644.96	641.66	645.07	646.04	646.38
221+84.00	31.83' RT	646.63	645.05	641.75	645.19	646.13	646.47
222+00.00	31.83' RT	646.68	645.10	641.80	645.25	646.18	646.51
222+14.00	31.83' RT	646.72	645.14	642.02	645.29	646.22	646.56
222+44.00	31.83' RT	646.81	645.23	642.48	645.38	646.31	646.65
222+74.00	31.83' RT	646.90	645.32	642.95	645.47	646.40	646.74
223+00.00	31.83' RT	646.98	645.40	643.35	645.55	646.48	646.81
223+04.00	31.83' RT	646.99	645.41	643.41	645.57	646.49	646.83
223+34.00	31.83' RT	647.08	645.50	643.87	645.70	646.58	646.92
223+64.00	31.83' RT	647.17	645.59	644.34	645.84	646.67	647.01
223+94.00	31.83' RT	647.26	645.68	644.80	645.97	646.76	647.10
224+00.00	31.83' RT	647.28	645.70	644.89	646.00	646.78	647.12
224+24.00	31.83' RT	647.38	645.80	644.77	646.18	646.88	647.21
224+54.00	31.83' RT	647.50	645.92	644.63	646.39	647.00	647.34
224+84.00	31.83' RT	647.63	646.04	644.48	646.61	647.13	647.46
225+00.00	31.83' RT	647.69	646.11	644.40	646.73	647.19	647.53
225+14.00	31.83' RT	647.75	646.17	644.36	646.70	647.25	647.59
225+44.00	31.83' RT	647.89	646.31	644.27	646.63	647.39	647.72
225+74.00	31.83' RT	648.02	646.44	644.19	646.56	647.52	647.86
226+00.00	31.83' RT	648.14	646.56	644.11	646.50	647.64	647.98
226+04.00	31.83' RT	648.16	646.58	644.04	646.52	647.66	647.99
226+34.00	31.83' RT	648.29	646.71	643.55	646.69	647.79	648.13
226+64.00	31.83' RT	648.43	646.84	643.05	646.85	647.93	648.26
226+94.00	31.83' RT	648.56	646.98	642.55	647.02	648.06	648.39
227+00.00	31.83' RT	648.59	647.00	642.45	647.05	648.09	648.42
227+24.00	31.83' RT	648.69	647.11	642.29	646.87	648.19	648.52
227+54.00	31.83' RT	648.82	647.24	642.10	646.65	648.32	648.66
227+84.00	31.83' RT	648.96	647.37	641.90	646.42	648.46	648.79
228+00.00	31.83' RT	649.03	647.45	641.80	646.30	648.53	648.86
228+14.00	31.83' RT	649.09	647.51	642.06	646.51	648.59	648.92
228+44.00	31.83' RT	649.22	647.64	642.62	646.96	648.72	649.06
228+74.00	31.83' RT	649.36	647.77	643.18	647.41	648.86	649.19
229+00.00	31.83' RT	649.47	647.89	643.66	647.80	648.97	649.31
229+04.00	31.83' RT	649.49	647.90	643.70	647.78	648.99	649.32
229+34.00	31.83' RT	649.59	648.01	643.96	647.60	649.09	649.43
229+64.00	31.83' RT	649.70	648.12	644.23	647.42	649.20	649.53
229+94.00	31.83' RT	649.81	648.22	644.50	647.24	649.31	649.64
230+00.00	31.83' RT	649.83	648.25	644.55	647.20	649.33	649.66
230+24.00	31.83' RT	649.91	648.33	644.42	647.30	649.41	649.75
230+54.00	31.83' RT	650.02	648.44	644.25	647.42	649.52	649.86
230+84.00	31.83' RT	650.13	648.55	644.09	647.54	649.63	649.96
231+00.00	31.83' RT	650.19	648.60	644.00	647.60	649.69	650.02
231+14.00	31.83' RT	650.24	648.65	643.87	647.60	649.74	650.07
231+44.00	31.83' RT	650.34	648.76	643.60	647.60	649.84	650.18
231+50.00	31.83' RT	650.37	648.78	643.54	647.60	649.87	650.20
231+74.00	31.83' RT	650.45	648.87	643.93	647.60	649.95	650.28
232+00.00	31.83' RT	650.54	648.96	644.35	647.60	650.04	650.38
232+04.00	31.83' RT	650.56	648.98	644.32	647.72	650.06	650.39
232+34.00	31.83' RT	650.67	649.08	644.12	648.59	650.17	650.50
232+64.00	31.83' RT	650.77	649.19	643.91	649.46	650.27	650.61
232+94.00	31.83' RT	650.88	649.30	643.71	650.33	650.38	650.71
233+00.00	31.83' RT	650.90	649.32	643.67	650.50	650.40	650.74
233+07.60	31.83' RT	650.96	649.38	643.61	650.47	650.46	650.80
233+25.00	43.76' RT	651.10	649.52	643.48	650.40	650.60	650.94
233+32.36	48.81' RT	651.57	649.98	646.39	650.49	651.07	651.40
233+49.50	73.41' RT	651.56	649.97	651.39	649.74	651.06	651.39

Elevation A = Top of Concrete Cap
 Elevation B = Bottom of Concrete Cap
 Elevation C = Finished Grade at Front Face of Wall
 Elevation D = Existing Grade at Front Face of Wall
 Elevation E = Top of Pile
 Elevation F = Finished Grade at Back Face of Wall

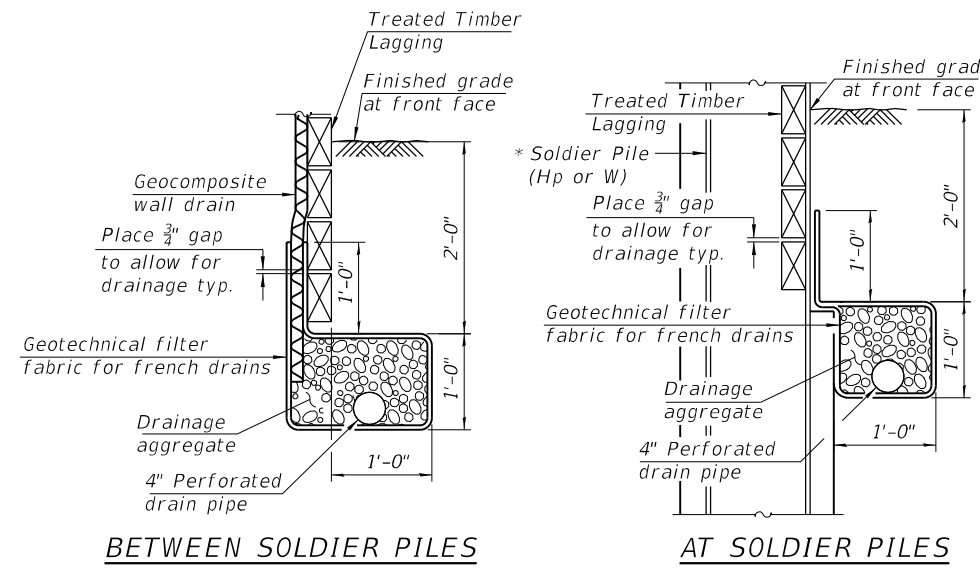
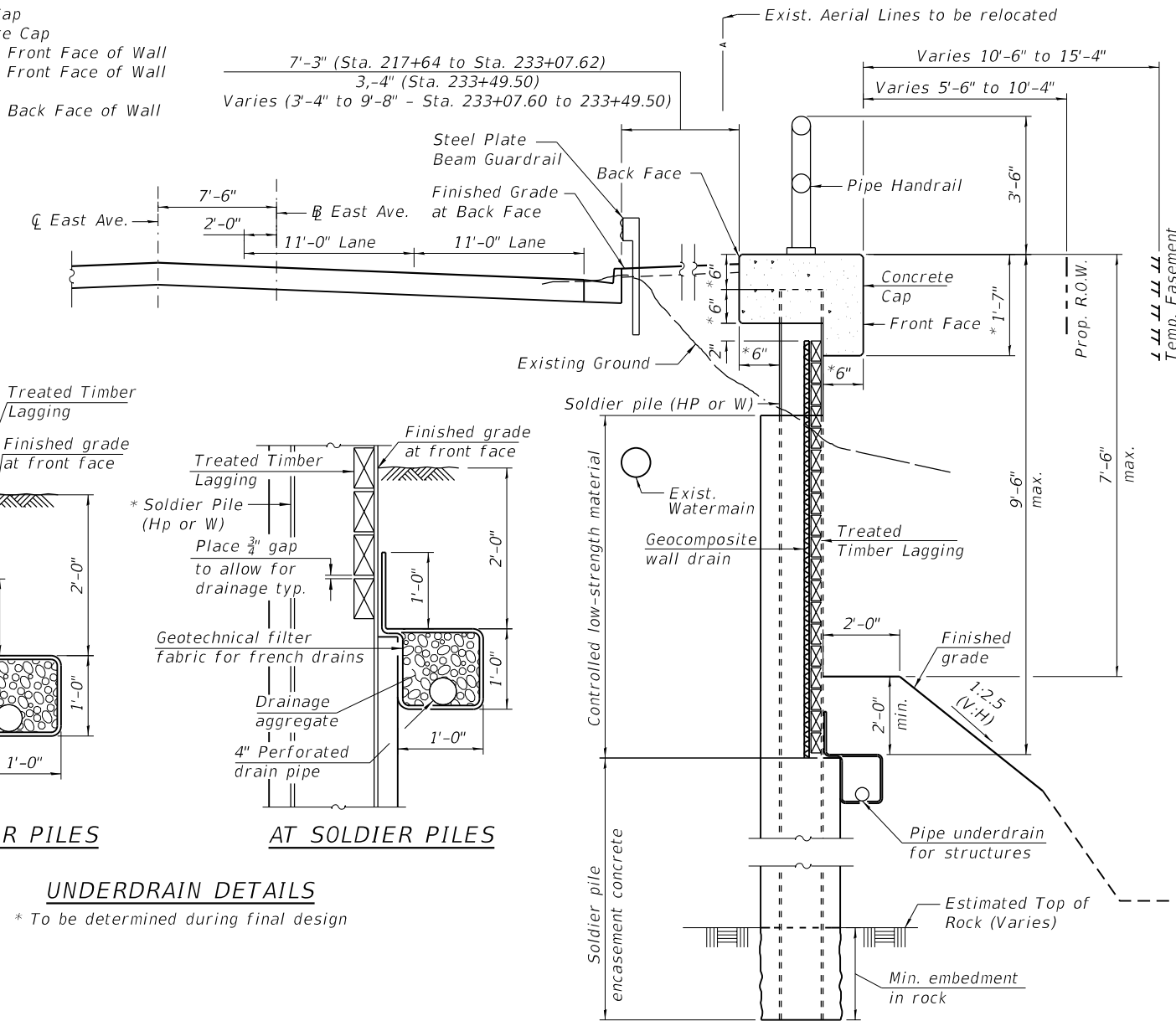

SECTION THRU SOLDIER PILE WALL WITHOUT CONCRETE FACING
 (Looking North)

Soldier Pile section, shaft diameter, spacing and tip elevation or embedment in rock, to be determined during final design.

* Concrete Cap dimensions to be finalized during final design.

CROSS SECTION & DETAILS RETAINING WALL ALONG F.A.U. RTE. 2719 (EAST AVENUE) SECTION 0102N&T COOK COUNTY STATION 217+64 TO 233+49.50 STRUCTURE NO. 016-Z022

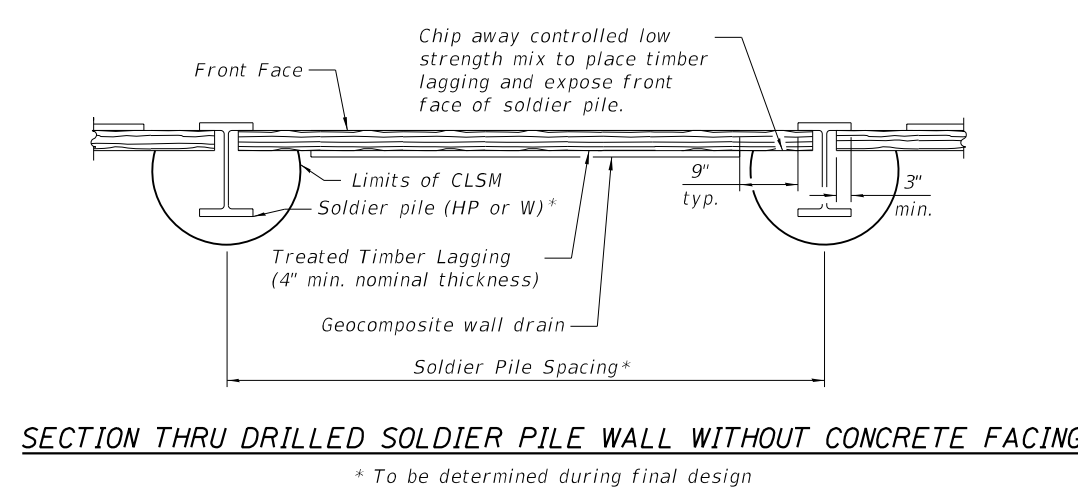

STATE OF ILLINOIS DEPARTMENT OF TRANSPORTATION

MODEL: Default
 FILE NAME: Q:\Engineering\Live\Projects\13031.IDOT.East.Ave.CADD\CADD_Sheets\Structural\5&L\162022-62C25-005-Details.dgn
 10/5/2018 4:26:43 PM



USER NAME = johnn	DESIGNED - SAT	REVISED -
PLOT SCALE = 0.1667 / in.	CHECKED - JMT	REVISED -
PLOT DATE = 10/5/2018	DRAWN - SAT	REVISED -
	CHECKED - SPS	REVISED -

F.A.U. RTE.	SECTION	COUNTY	TOTAL SHEETS	SHEET NO.
2719	0102N&T	COOK	5	6
CONTRACT NO. 62C25				

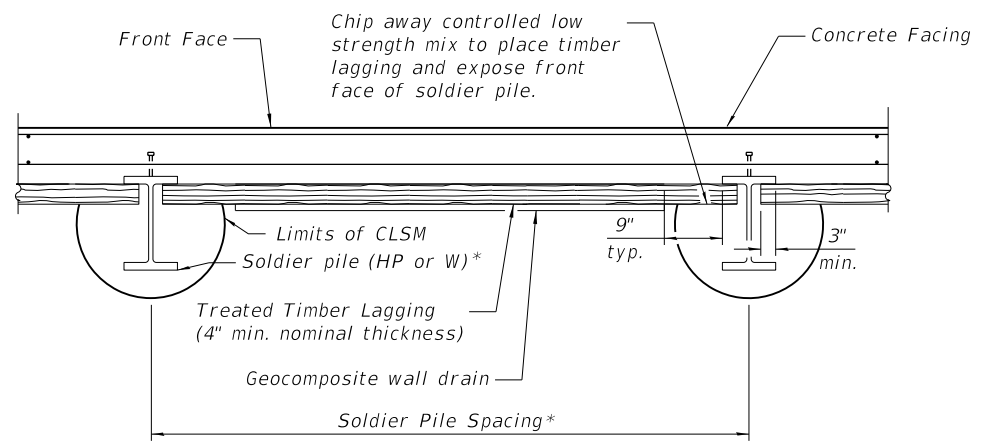

SECTION THRU DRILLED SOLDIER PILE WALL WITH CONCRETE FACING

* To be determined during final design

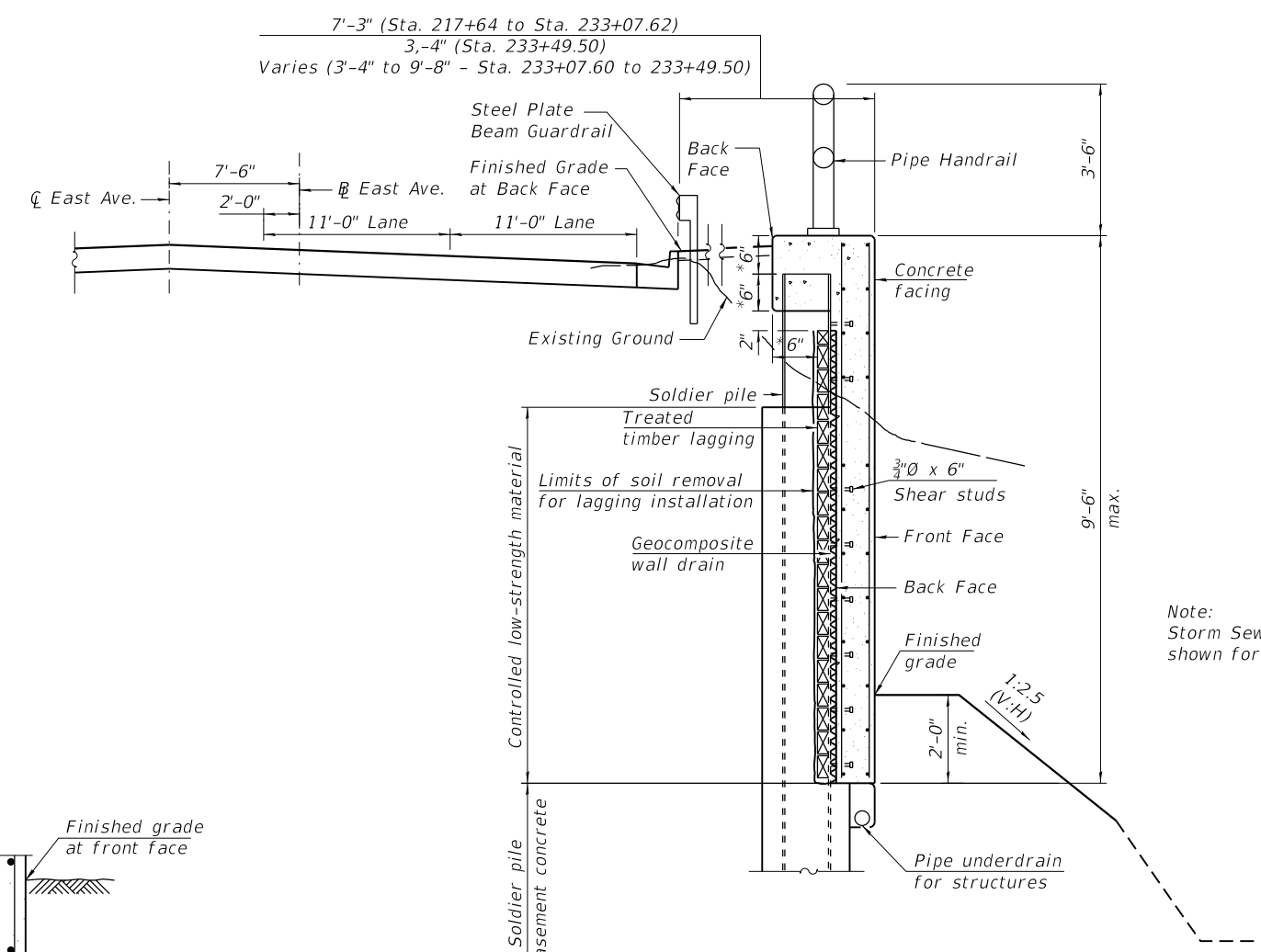

SECTION THRU SOLDIER PILE WALL WITH CONCRETE FACING
(At locations with storm sewer passing thru the wall)

Soldier Pile section, shaft diameter, spacing and tip elevation or embedment in rock, to be determined during final design.

* Concrete Cap dimensions to be finalized during final design.

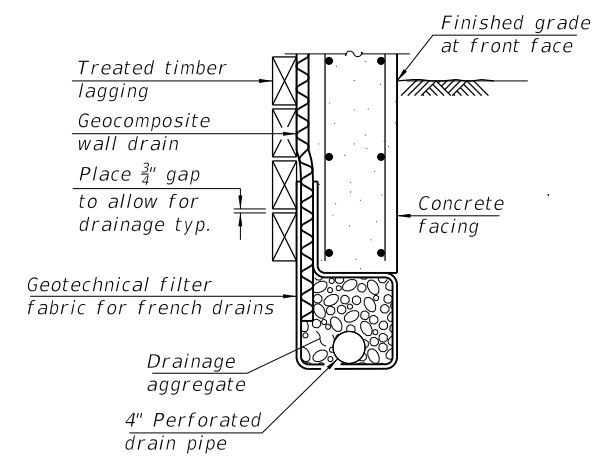

BETWEEN SOLDIER PILES

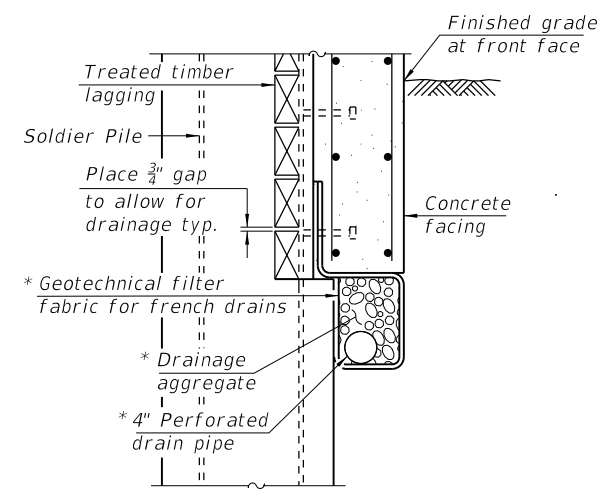

AT SOLDIER PILES

PIPE UNDERDRAIN DETAILS

MODEL: Default
FILE NAME: Q:\Engineering\Live\Projects\13031 IDOT East Ave\CADD\CADD Sheets\Structural\TS&L\16Z022-62C25-006-Details.dgn



USER NAME = JENT	DESIGNED - SAT	REVISED -
PLOT SCALE = 0.1667 1/in.	CHECKED - JMT	REVISED -
PLOT DATE = 10/8/2018	DRAWN - SAT	REVISED -
	CHECKED - SPS	REVISED -

STATE OF ILLINOIS
DEPARTMENT OF TRANSPORTATION

SHEET 6 OF 6 SHEETS

**CROSS SECTION & DETAILS
RETAINING WALL ALONG
F.A.U. RTE. 2719 (EAST AVENUE)
SECTION 0102N&T
COOK COUNTY
STATION 217+64 TO 233+49.50
STRUCTURE NO. 016-Z022**

F.A.U. RTE. 2719	SECTION 0102N&T	COUNTY COOK	TOTAL SHEETS 6	SHEET NO. 6
CONTRACT NO. 62C25				
ILLINOIS FED. AID PROJECT				