

F.A.P.	SECTION	COUNTY	TOTAL SHEETS	SHEET NO.
330	465 VB-R-1	COOK	103	54
STA. 173+50 TO STA. 195+00		ILLINOIS FED. AID PROJECT		
FED. ROAD DIST. NO. 7		Contract # 60407 SHEET NO. 521 of 560		

\*Granular or solid flux filled headed studs conforming to Article 1006.32 of the Std. Specs., automatically end welded.

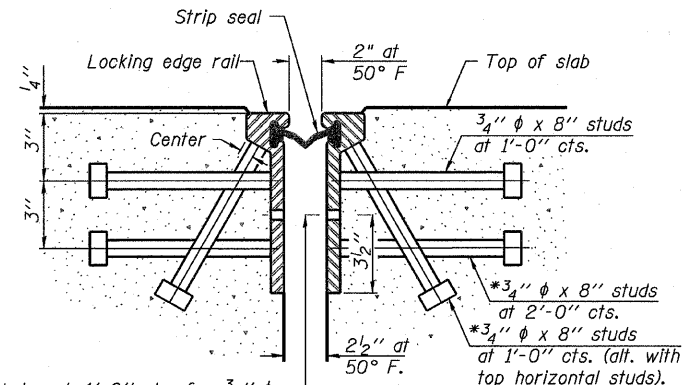

7/16"  $\phi$  holes at 4'-0" cts. for 3/8"  $\phi$  bolts. All bolts shall be burned, sawed, or chipped off flush with the plates after forms are removed, typ.

**SECTION THRU ROLLED RAIL JOINT**

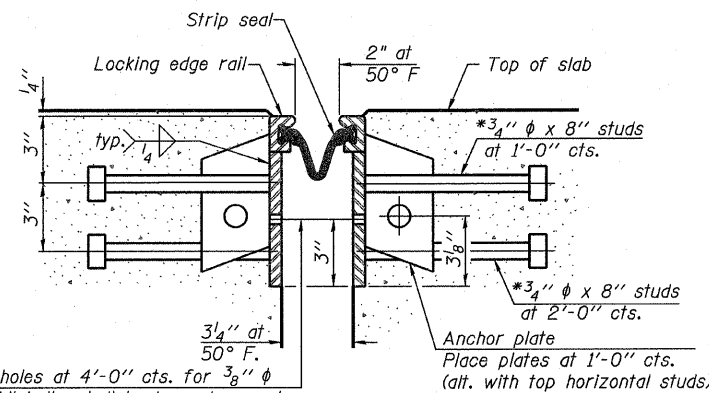

7/16"  $\phi$  holes at 4'-0" cts. for 3/8"  $\phi$  bolts. All bolts shall be burned, sawed, or chipped off flush with the plates after forms are removed, typ.

**SECTION THRU WELDED RAIL JOINT**

**Notes:**

The strip seal shall be made continuous and shall have a minimum thickness of 1/4". The configuration of the strip seal shall match the configuration of the Locking Edge Rails. Open or "webbed" strip seal gland configurations are not permitted. The gland shall be sized for a maximum rated movement of 4 inches.

The height and thickness of the Locking Edge Rails shown are minimum dimensions. The actual configuration of the Locking Edge Rails and matching strip seal may vary from manufacturer to manufacturer. Flanged edge rails will not be allowed. Locking Edge Rails may be spliced at slope discontinuities and stage construction joints.

The manufacturer's recommended installation methods shall be followed.

The joint opening and deck dimensions detailed on the superstructure are based on a rolled rail expansion joint. If the Contractor elects to use the welded rail expansion joint, the opening and deck dimensions shall be modified according to the dimensions detailed on this sheet. Required modifications shall be made at no additional cost to the State.

All steel components shall be galvanized after fabrication according to Article 520.03 of the Standard Specifications.

Cost of all sliding plates, stud shear connectors, & connections shall be included with "Preformed Joint Strip Seal".

Exposed surfaces of top sliding plates shall be textured to meet all ADA requirements.

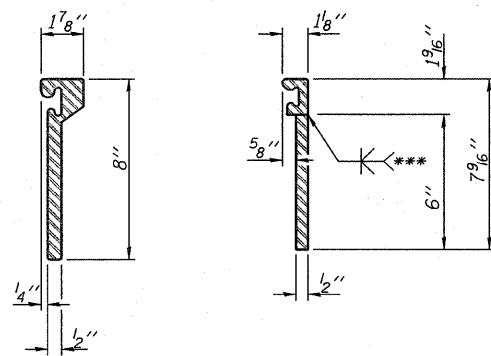

**ROLLED (EXTRUDED) RAIL**      **WELDED RAIL**

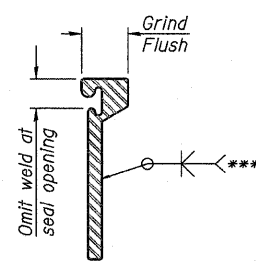

\*\*\*Back gouge not required if complete joint penetration is verified by mock-up.

**LOCKING EDGE RAIL SPLICE**

The inside of the locking edge rail groove shall be free of weld residue.

**LOCKING EDGE RAILS**

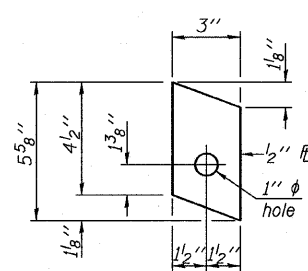

**ANCHOR PLATE (for welded rail)**

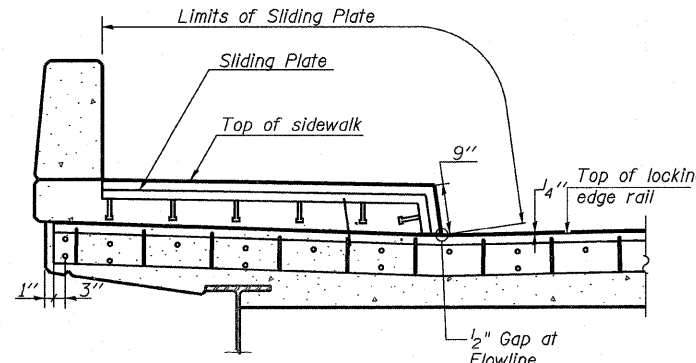

**TYPICAL END TREATMENT AT WEST SIDEWALK (Looking North)**

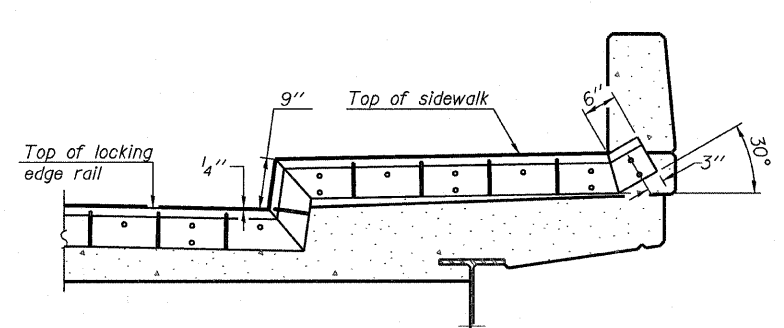

**TYPICAL END TREATMENT AT EAST SIDEWALK (Looking North)**

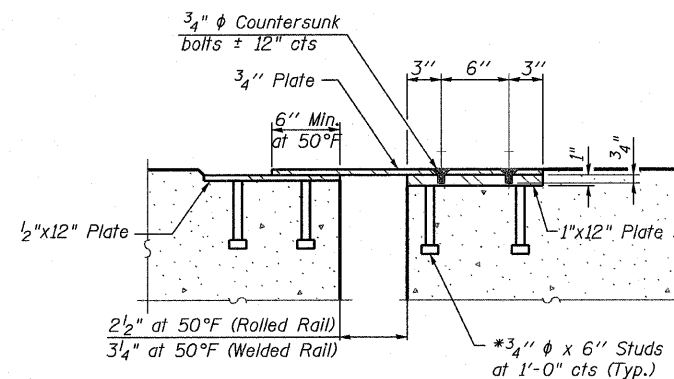

**SECTION THRU SLIDING PLATE**

**BILL OF MATERIAL**

Item	Unit	Total
Preformed Joint Strip Seal	Foot	200

REVISIONS		ILLINOIS DEPARTMENT OF TRANSPORTATION
NAME	DATE	
		<b>PREFORMED JOINT STRIP SEAL</b> FAP 330 US 12/45 (MANNHEIM RD.) OVER 500 LINE RR & FRANKLIN AVE. STRUCTURE NO. 016-2815 SECTION 465 VB-R-1 STA. 183+33.30 DATE 7/2009

**EARTHTECH | AECOM**

COOK COUNTY  
DRAWN BY JHR  
CHECKED BY CLS