

STATE OF ILLINOIS  
DEPARTMENT OF TRANSPORTATION

F.A.R.T.E.	SECTION	COUNTY	TOTAL SHEETS	SHEET NO.
2843	3249B-R	COOK	64	24
FED. ROAD DIST. NO.		ILLINOIS	FED. AID PROJECT-	
			Sheet 3 of 3 Contract No. 62539	

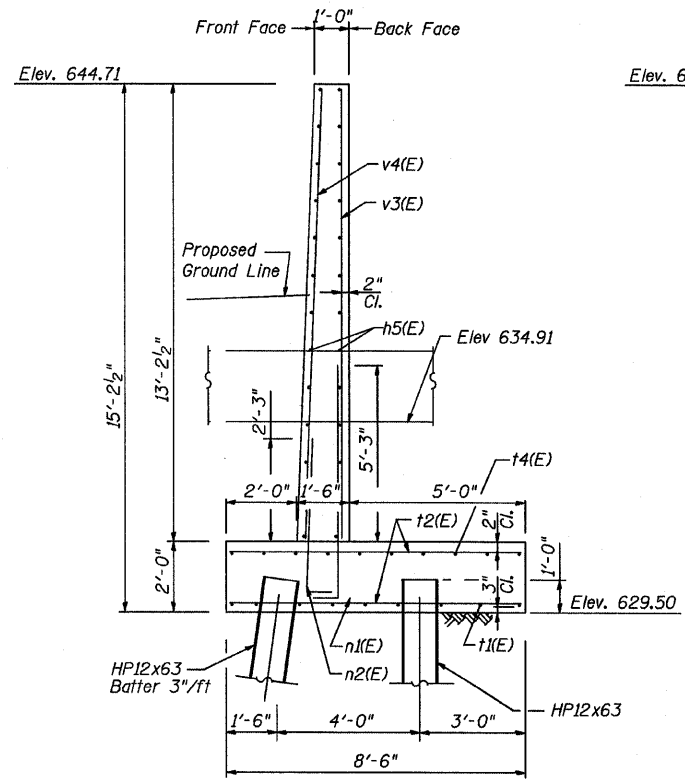

SECTION A-A

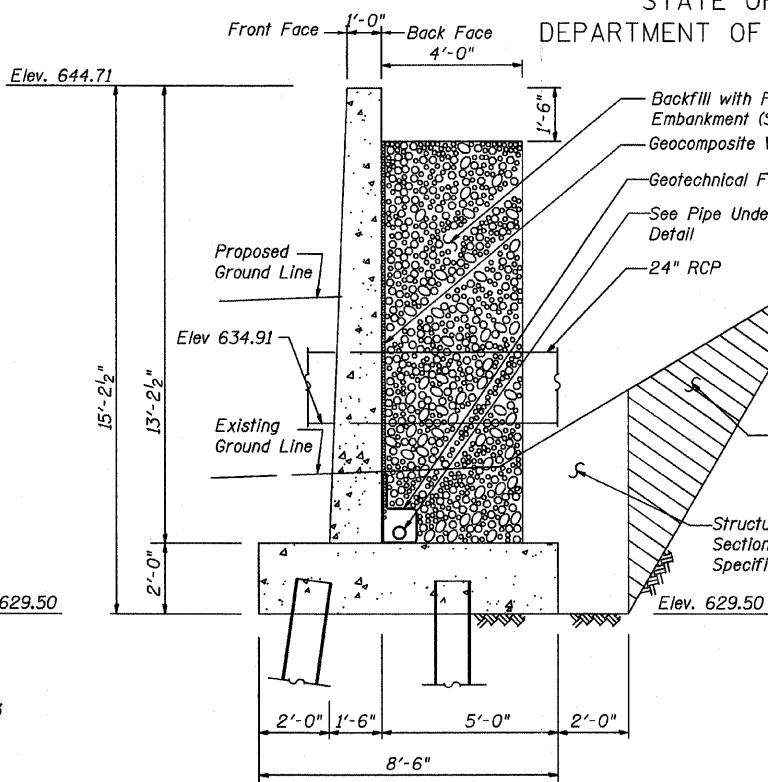

SECTION SHOWING DRAINAGE

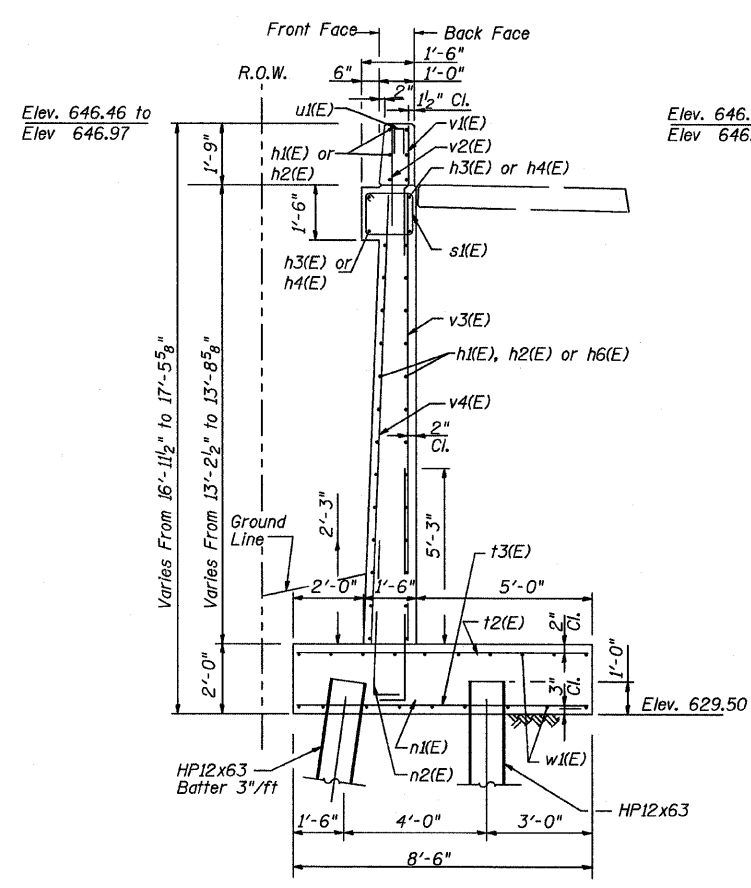

SECTION SHOWING REINFORCEMENT

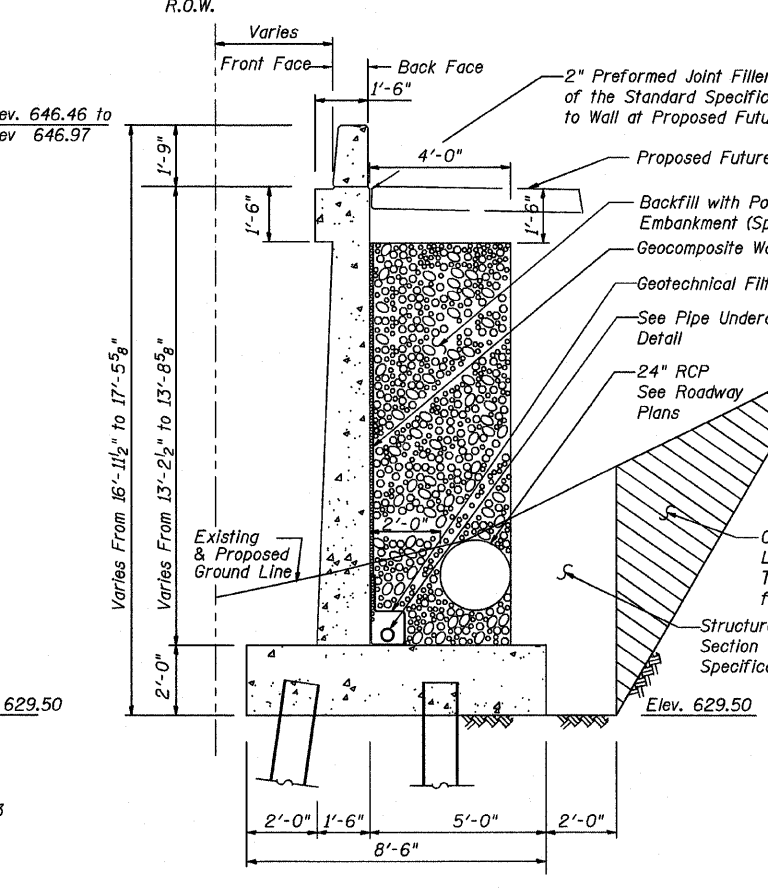

SECTION SHOWING DRAINAGE

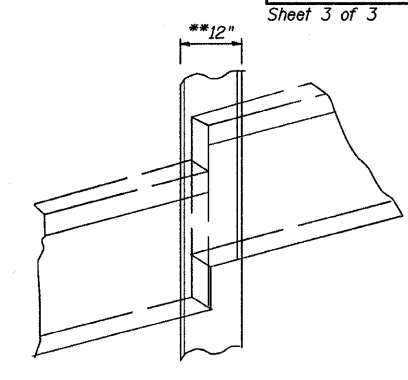
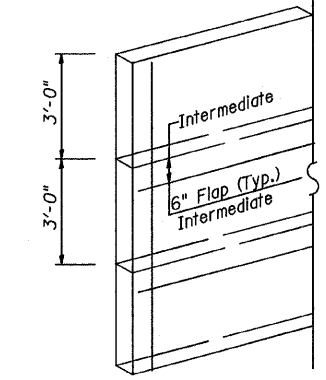
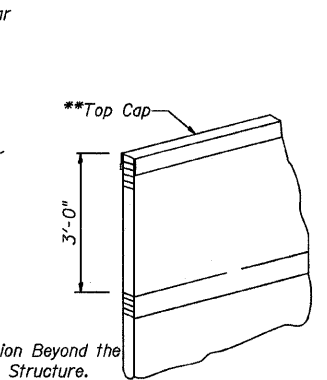

\*\*GEOCOMPOSITE WALL DRAIN DETAILS  
See Special Provisions

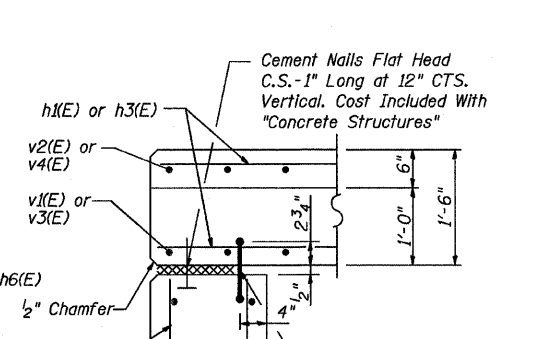
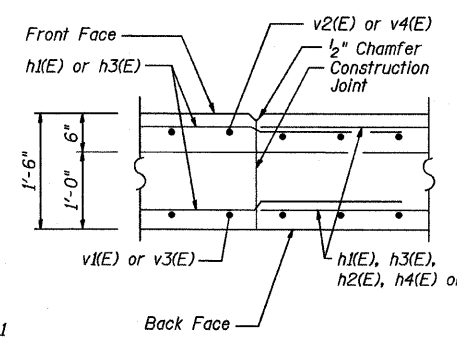

CONSTRUCTION JOINT DETAIL

EXPANSION JOINT DETAIL

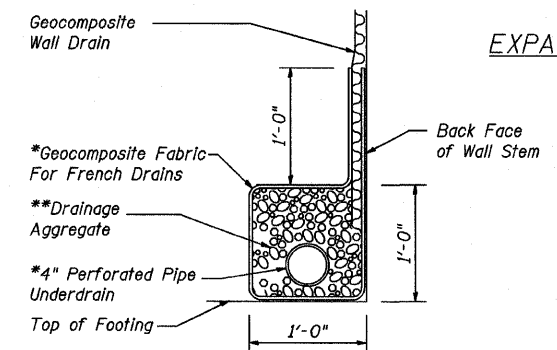

PIPE UNDERDRAIN DETAIL

BAR s1(E)

PILE DATA

Type: HP12x63  
Nominal Required Bearing: 497 Kips  
Allowable Resistance Available: 166 Kips  
Est. Total Length: 40'-0"  
No. Required: 39 + 1 Test Pile  
Negative Skin Friction: 30 Kips/Pile  
Provide Pile Shoes for all Piles

RETAINING WALL  
BILL OF MATERIAL

Bar	No.	Size	Length	Shape
h1(E)	64	#4	34'-3"	—
h2(E)	24	#4	31'-9"	—
h3(E)	8	#5	34'-9"	—
h4(E)	4	#5	31'-9"	—
h5(E)	28	#4	12'-1"	—
h6(E)	8	#4	28'-11"	—
h7(E)	8	#5	4'-0"	—
n1(E)	110	#8	8'-4"	—
n2(E)	110	#5	4'-8"	—
s1(E)	100	#4	5'-5"	□
t1(E)	9	#6	15'-9"	—
t2(E)	108	#7	8'-3"	—
t3(E)	85	#6	8'-3"	—
t4(E)	10	#7	15'-9"	—
u1(E)	100	#4	2'-0"	□
v1(E)	100	#6	4'-4"	—
v2(E)	100	#4	3'-5"	—
v3(E)	110	#6	13'-0"	—
v4(E)	110	#4	13'-0"	—
v5(E)	8	#5	9'-4"	—
w1(E)	57	#5	34'-1"	—
Reinforcement Bars, Epoxy Coated	Pound			15800
Concrete Structures	Cu. Yds.			146
Furnishing Steel Piles HP12x63	Foot			1560
Driving Piles	Foot			1560
Test Pile Steel, HP12x63	Each			1
Pile Shoes	Each			39

SECTIONS, DETAILS & BILL OF MATERIAL

DIXIE HIGHWAY OVER BUTTERFIELD CREEK  
F.A.U. ROUTE 2843 SECTION 3249B-R  
STA. 78+55.00  
COOK COUNTY  
STRUCTURE NUMBER 016-W962

REVISIONS	
NAME	DATE

SCALE: NOT-TO-SCALE  
DATE 6-30-09

DRAWN BY BV  
DESIGNED BY BS  
CHECKED BY PK



#PENTBLSP  
#PLTDIVS#

#FILES  
#DATE  
#TIMES