

| F.A. RTE. | SECTION | COUNTY | TOTAL SHEETS | SHEET NO. |
|--------------|---------|--------|---|-----------|
| 2843 | 3249B-R | COOK | 64 | 52 |
| STA. TO STA. | | | FED. ROAD DIST. NO. 1 ILLINOIS FED. AID PROJECT | |

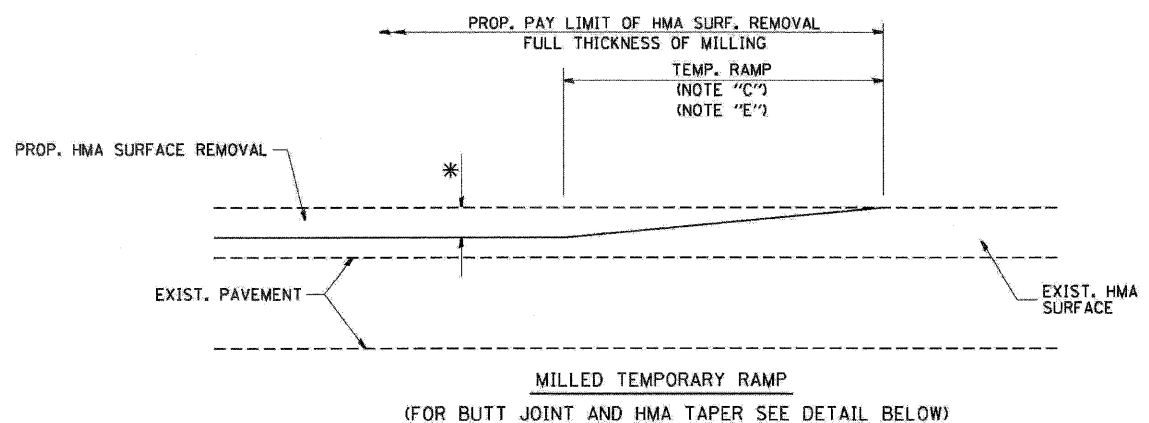

OPTION 1

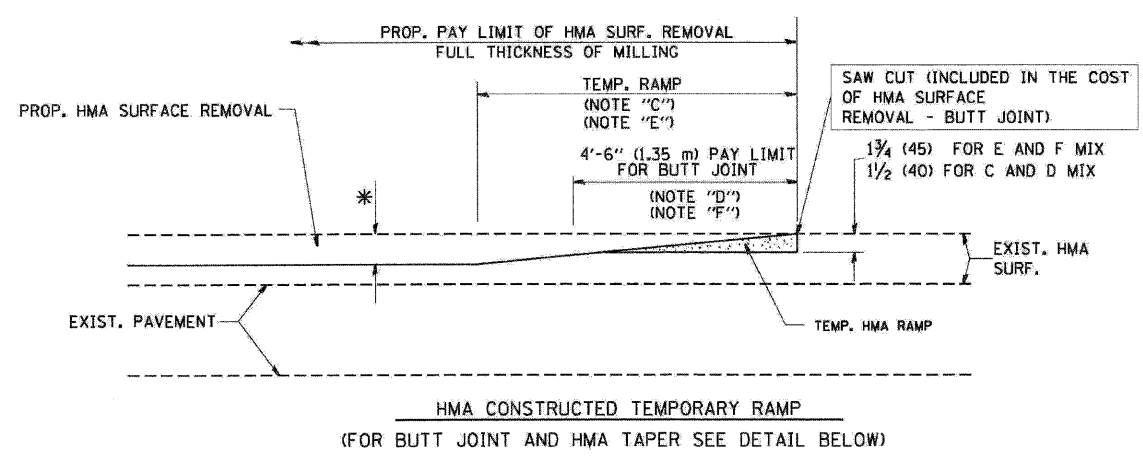

OPTION 2
TYPICAL TEMPORARY RAMP

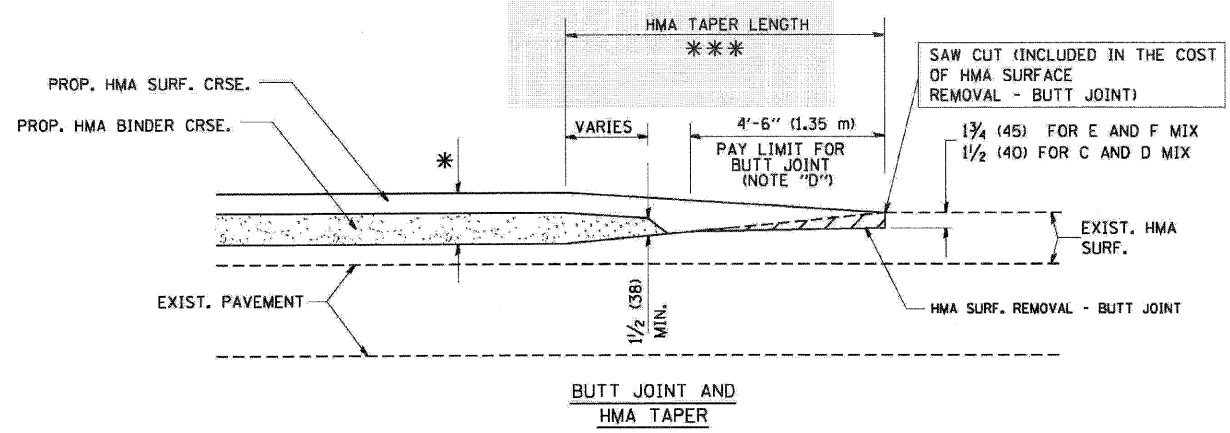

TYPICAL BUTT JOINT AND HMA TAPER FOR MILLING AND RESURFACING

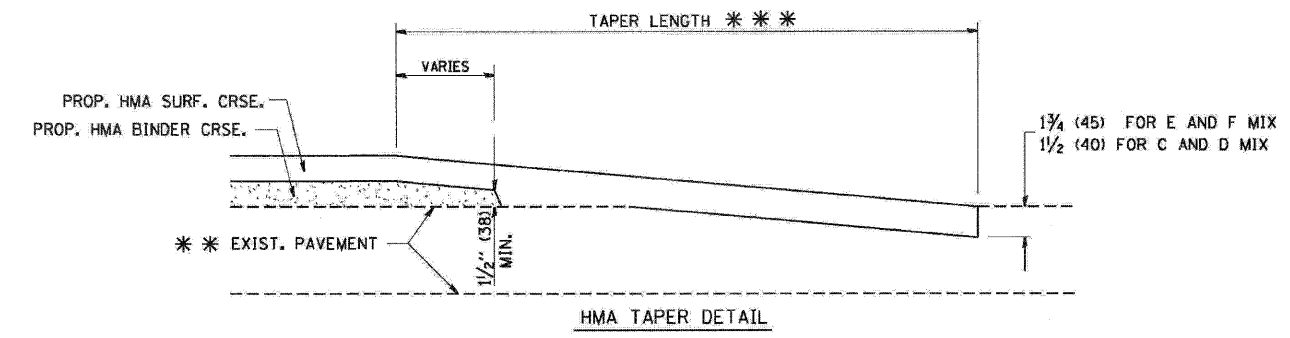
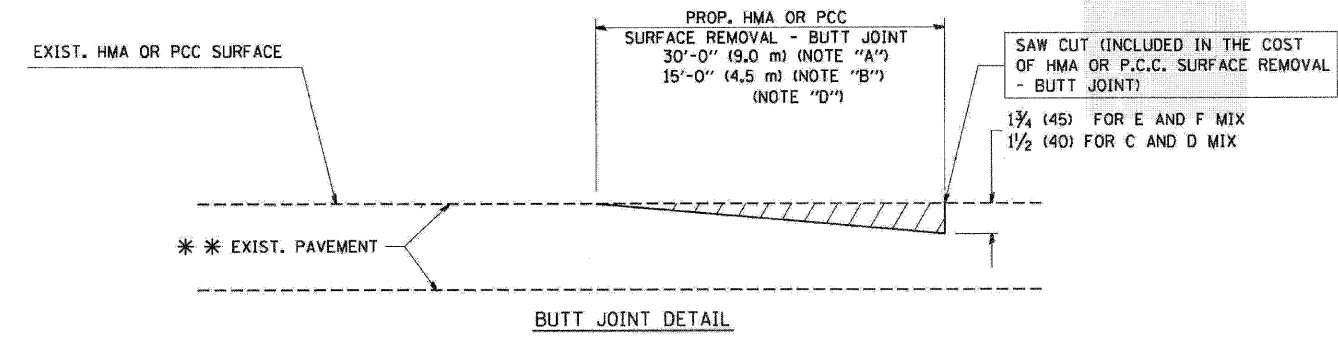

TYPICAL BUTT JOINT AND HMA TAPER FOR RESURFACING ONLY

*** PC CONCRETE, HMA OR HMA RESURFACED PAVEMENT.

NOTES

- A: MAINLINE ROADWAYS AND MAJOR SIDE ROADS.
 - B: MINOR SIDE ROADS.
 - C: THE TEMP. RAMP SHALL BE CONSTRUCTED IMMEDIATELY UPON REMOVAL OF THE EXISTING HMA SURFACE.
 - D: THE BUTT JOINT SHALL BE CONSTRUCTED IMMEDIATELY PRIOR TO PLACING THE PROPOSED HMA COURSES.
 - E: TAPER THE TEMP. RAMP AT A RATE OF 3'-0" (900 mm) PER 1 INCH (25 mm) OF MILLING THICKNESS.
 - F: INSTALLATION AND REMOVAL OF THE 4'-6" (1.35 m) TEMP. RAMP IS INCLUDED IN COST OF HMA SURFACE REMOVAL - BUTT JOINT
 - G: SEE ARTICLE 406.08 AND 406.14 OF THE STANDARD SPECIFICATIONS FOR "HMA AND/OR PCC SURFACE REMOVAL, BUTT JOINT".
- *** SEE TYPICAL SECTIONS FOR MILLING THICKNESS.
- *** 20'-0" (6.1 m) PER 1 (25) RESURFACING (NOTE "A")
10'-0" (3.0 m) PER 1 (25) RESURFACING (NOTE "B")

ALL DIMENSIONS ARE IN INCHES (MILLIMETERS) UNLESS OTHERWISE SHOWN.

BASIS OF PAYMENT:

THE BUTT JOINT WILL BE PAID FOR AT THE CONTRACT UNIT PRICE PER SQUARE YARD (SQUARE METER) FOR "HOT-MIX ASPHALT SURFACE REMOVAL - BUTT JOINT" OR FOR "PORTLAND CEMENT CONCRETE SURFACE REMOVAL - BUTT JOINT".

| REVISIONS | |
|------------|----------|
| NAME | DATE |
| M. DE YONG | 6-13-90 |
| M. DE YONG | 7-3-90 |
| M. DE YONG | 3-27-92 |
| R. SHAH | 09/09/94 |
| R. SHAH | 10/25/94 |
| A. ABBAS | 03/21/97 |
| M. GOMEZ | 04/06/01 |
| R. BORO | 01/01/07 |

ILLINOIS DEPARTMENT OF TRANSPORTATION
F.A.U. 2843 DIXIE HWY over BUTTERFIELD CREEK
BUTT JOINT AND HMA TAPER DETAILS

SCALE: VERT. NONE
HORIZ. NONE

DRAWN BY
CHECKED BY
BD400-05 (VI=BD32)

PLOT DATE = 3/15/2007
FILE NAME = K:\ntas\bd32.dgn
USER NAME = bbor32