

STATE OF ILLINOIS
DEPARTMENT OF TRANSPORTATION
DIVISION OF HIGHWAYS

PLANS FOR PROPOSED FEDERAL AID HIGHWAY

F. A. IL. NO.	SECTION	COUNTY	TOTAL SHEETS	SHEET NO.
0282	09-00053-00-RS	WILL.	11	1
STA.	TO STA.			
FED. ROAD DIST. NO. 1	ILLINOIS	FED. AID PROJECT ARA-9003-(361)		

CONTRACT #63264

INDEX OF SHEETS

1. COVER SHEET, INDEX OF SHEETS, LOCATION MAP, INDEX OF STATE STANDARDS
2. SUMMARY OF QUANTITIES & GENERAL NOTES
3. TYPICAL CROSS SECTIONS
- 4.-5. PAVEMENT & STRIPING PLAN
- 6.-11. DISTRICT ONE STANDARD DETAILS

HIGHWAY STANDARDS

000001-05	STANDARD SYMBOLS, ABBREVIATIONS AND PATTERNS
280001-04	TEMPORARY EROSION CONTROL SYSTEMS
442201-03	CLASS C AND D PATCHES
701601-06	URBAN LANE CLOSURE, MULTILANE, 1W OR 2W WITH NONTRAVERSABLE MEDIAN
701606-06	URBAN LANE CLOSURE, MULTILANE, 2W WITH MOUNTABLE MEDIAN
701701-06	URBAN LANE CLOSURE, MULTILANE INTERSECTION
701901-01	TRAFFIC CONTROL DEVICES
780001-02	TYPICAL PAVEMENT MARKINGS

**FAU 0282/135TH STREET RESURFACING
IL-53 TO SANITARY & SHIP CANAL BRIDGE
LOCAL AGENCY PAVEMENT PRESERVATION
STREET RESURFACING
PROJECT: ARA-9003-(361)
SECTION NO.: 09-00053-00-RS
JOB NO.: C-91-676-09
VILLAGE of ROMEOVILLE
WILL COUNTY**

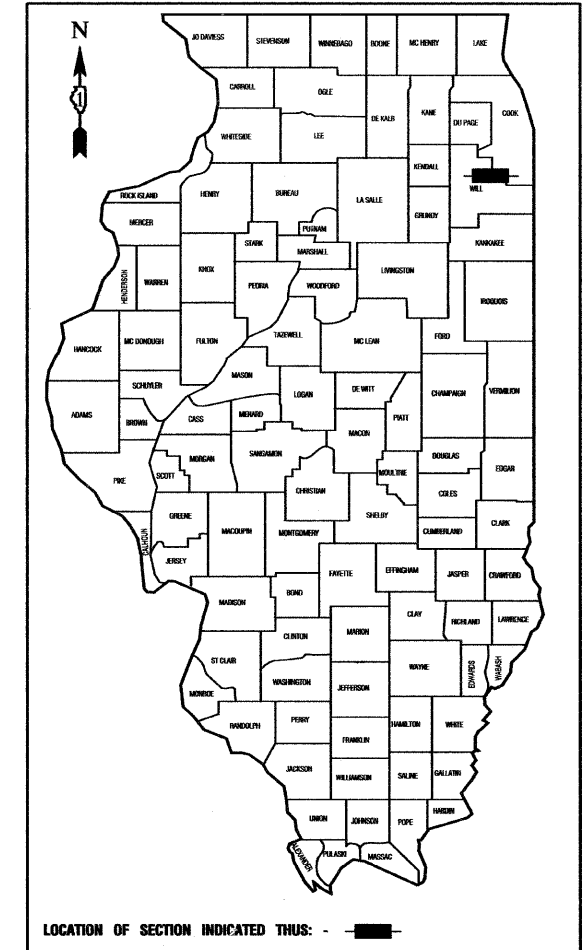

I.D.O.T. FEDERAL AID DESIGN ENGINEER: MELCHOR MANGOBA, P.E. 847-705-4408
CONSULTANTS: ROBINSON ENGINEERING, LTD. HARRY L. GILMORE, JR., P.E. 815-806-0300

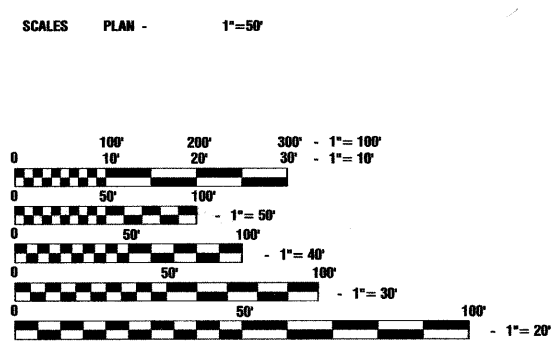

FULL SIZE PLANS HAVE BEEN PREPARED USING STANDARD ENGINEERING SCALES, REDUCED SIZED PLANS WILL NOT CONFORM TO STANDARD SCALES, IN MAKING MEASUREMENTS ON REDUCED PLANS, THE ABOVE SCALES MAY BE USED.

J. U. L. I. E.
JOINT UTILITY LOCATION INFORMATION FOR EXCAVATION
1-800-892-0123 or 811

CONTRACT NO. 63264

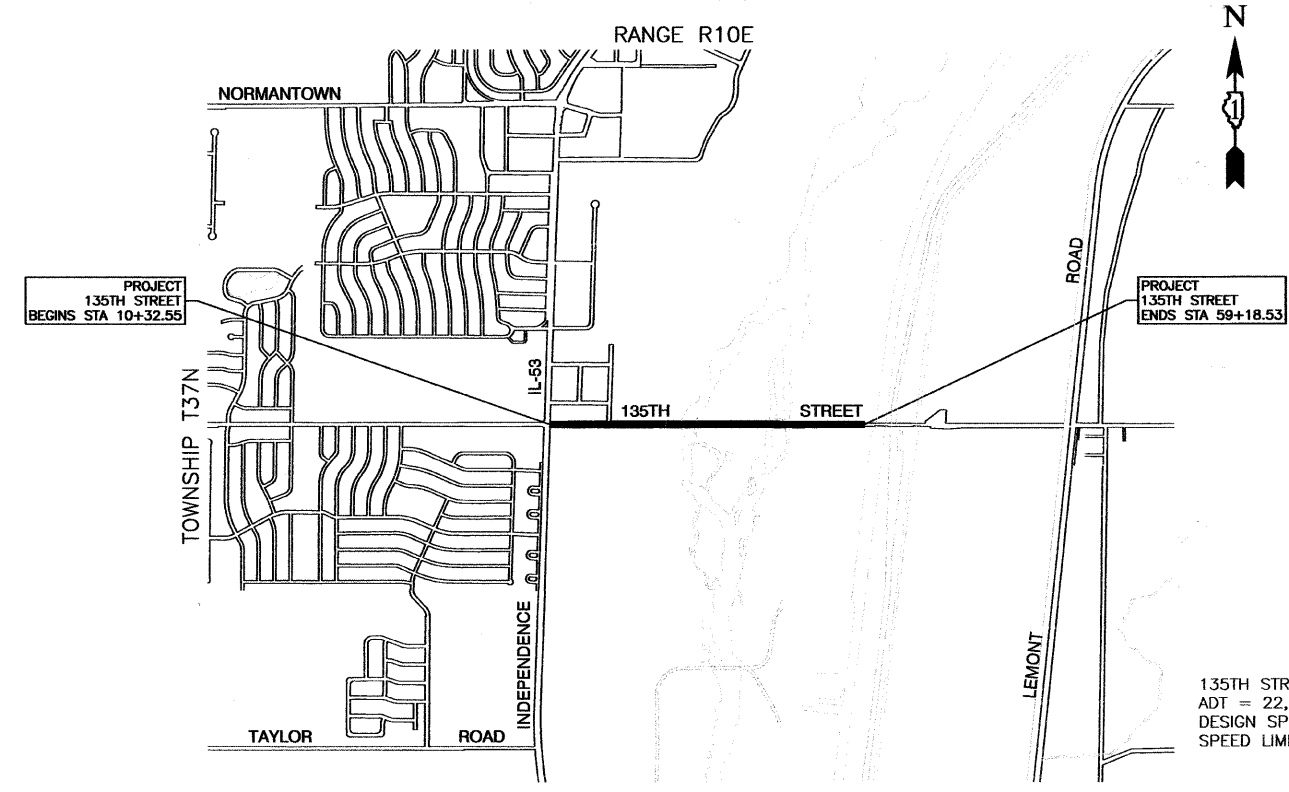

LOCATION MAP

GROSS LENGTH=4,885.98 FEET=0.93 MILES
NET LENGTH=4,274.24 FEET=0.81 MILES

STATE OF ILLINOIS DEPARTMENT OF TRANSPORTATION
DIVISION OF HIGHWAYS

Approved: John D. Mohr July 22, 2009
President, Village of Romeoville

Passed: Christophe Holt August 31, 2009
District 1 Engineer of Local Roads & Streets

Released for Bid Based on Limited Review: Diane M. O'Keefe September 1, 2009
Deputy Director of Highways, Region 1 Engineer

PRINTED BY THE AUTHORITY OF
THE STATE OF ILLINOIS

PREPARED BY OR UNDER THE DIRECT SUPERVISION OF:
Harry L. Gilmore, Jr. 7/22/09
REGISTERED PROFESSIONAL ENGINEER
STATE OF ILLINOIS
LICENSE EXPIRES: 11/30/09

SUMMARY OF QUANTITIES					PAVEMENT	MARKINGS
S.I.	CODE NO.	PAY ITEM	UNIT	QUAN	CONSTRUCTION CODE	
					I000	SFTY-1D
	35501308	HOT-MIX ASPHALT BASE COURSE, 6"	SQ YD	26	26	
	40600100	BITUMINOUS MATERIALS (PRIME COAT)	GALLON	2377	2377	
	40600300	AGGREGATE (PRIME COAT)	TON	36	36	
	40600895	CONSTRUCTING TEST STRIP	EACH	1	1	
	40600982	HOT-MIX ASPHALT SURFACE REMOVAL - BUTT JOINT	SQ YD	535	535	
	40603310	HOT-MIX ASPHALT SURFACE COURSE, MIX "C", N50	TON	3	3	
	40603340	HOT-MIX ASPHALT SURFACE COURSE, MIX "D", N70	TON	2000	2000	
	42400200	PORTLAND CEMENT CONCRETE SIDEWALK 5 INCH	SQ FT	868	868	
	44000157	HOT-MIX ASPHALT SURFACE REMOVAL, 2"	SQ YD	23772	23772	
	44000200	DRIVEWAY PAVEMENT REMOVAL	SQ YD	62	62	
	44000600	SIDEWALK REMOVAL	SQ FT	716	716	
	44001700	COMBINATION CONCRETE CURB AND GUTTER REMOVAL AND REPLACEMENT	FOOT	300	300	
	44201757	CLASS D PATCHES, TYPE III, 9 INCH	SQ YD	200	200	
	44201759	CLASS D PATCHES, TYPE IV, 9 INCH	SQ YD	100	100	
	60255500	MANHOLES TO BE ADJUSTED	EACH	14	14	
	60260100	INLETS TO BE ADJUSTED	EACH	10	10	
	67100100	MOBILIZATION	L SUM	1	1	
	70101800	TRAFFIC CONTROL AND PROTECTION, (SPECIAL)	L SUM	1	1	
	70106800	CHANGEABLE MESSAGE SIGN	CAL MO	4	4	
	70300100	SHORT-TERM PAVEMENT MARKING	FOOT	3150		3150
	70300210	TEMPORARY PAVEMENT MARKING - LETTERS AND SYMBOLS	SQ FT	438		438
*	78000100	THERMOPLASTIC PAVEMENT MARKING - LETTERS AND SYMBOLS	SQ FT	182		182
*	78000200	THERMOPLASTIC PAVEMENT MARKING - LINE 4"	FOOT	11472		11472
*	78000400	THERMOPLASTIC PAVEMENT MARKING - LINE 6"	FOOT	850		850
*	78000600	THERMOPLASTIC PAVEMENT MARKING - LINE 12"	FOOT	120		120
*	78000650	THERMOPLASTIC PAVEMENT MARKING - LINE 24"	FOOT	90		90
*	78300200	RAISED REFLECTIVE PAVEMENT MARKER REMOVAL	EACH	220		220
*	88600600	DETECTOR LOOP REPLACEMENT	FOOT	371		371
	X4067107	POLYMERIZED LEVELING BINDER (MACHINE METHOD), IL-4.75, N50	TON	1000	1000	

* - INDICATES SPECIALTY ITEMS

GENERAL NOTES:

- BEFORE STARTING ANY EXCAVATION, THE CONTRACTOR SHALL CALL "J.U.L.I.E." AT (800) 892-0123 FOR FIELD LOCATIONS OF BURIED ELECTRIC, TELEPHONE AND GAS UTILITIES. (48 HOUR NOTIFICATION IS REQUIRED).
- UTILITIES INDICATED ON THE PLANS ARE PROVIDED FOR THE CONTRACTORS USE AND ARE BASED UPON INFORMATION AVAILABLE AT THE TIME OF THE ADVERTISEMENT FOR BIDS. THE OWNER AND ENGINEER DO NOT GUARANTEE THE ACCURACY OF UTILITIES INFORMATION.
- IT SHALL BE THE CONTRACTOR'S RESPONSIBILITY TO VERIFY ALL DIMENSIONS AND CONDITIONS EXISTING IN THE FIELD PRIOR TO CONSTRUCTION AND ORDERING OF MATERIALS.
- EXACT LOCATIONS FOR PATCHING SHALL BE DETERMINED IN THE FIELD BY THE ENGINEER.
- ANY REFERENCE TO STANDARDS THROUGHOUT THE PLANS OR SPECIAL PROVISIONS SHALL BE INTERPRETED TO BE THE LATEST STANDARDS OF THE ILLINOIS DEPARTMENT OF TRANSPORTATION.
- THE NOMINAL THICKNESS OF HOT-MIX ASPHALT MIXTURE STATED IN THE SPECIFICATIONS IS THE NOMINAL THICKNESS. DEVIATIONS FROM THE NOMINAL THICKNESS WILL BE PERMITTED WHEN SUCH DEVIATIONS OCCUR DUE TO IRREGULARITIES IN THE EXISTING SURFACE OR BASE ON WHICH THE HOT-MIX ASPHALT SURFACE IS PLACED.
- CHANGEABLE MESSAGE SIGNS SHALL BE ERECTED AT LEAST 10 DAYS PRIOR TO START OF CONSTRUCTION.

FILE NAME = 09275-QUAN-01 - 001

USER NAME =	DESIGNED -- JRD	REVISED --
	CHECKED -- HLG	REVISED --
PLOT SCALE =	DRAWN -- LTL	REVISED --
PLOT DATE = 08-07-09	CHECKED -- HLG	REVISED --

STATE OF ILLINOIS
DEPARTMENT OF TRANSPORTATION

135TH STREET RESURFACING
IL-53 TO SANITARY & SHIP CANAL BRIDGE
SUMMARY OF QUANTITIES
SCALE: NONE SHEET NO. 2 OF 11 SHEETS STA. TO STA.

F.A.U. RTE.	SECTION	COUNTY	TOTAL SHEETS	SHEET NO.
0282	09-00053-00-RS	WILL	11	2
CONTRACT NO. 63264				
FED. ROAD DIST. NO. 1 ILLINOIS FED. AID PROJECT ARA-9003-(361)				

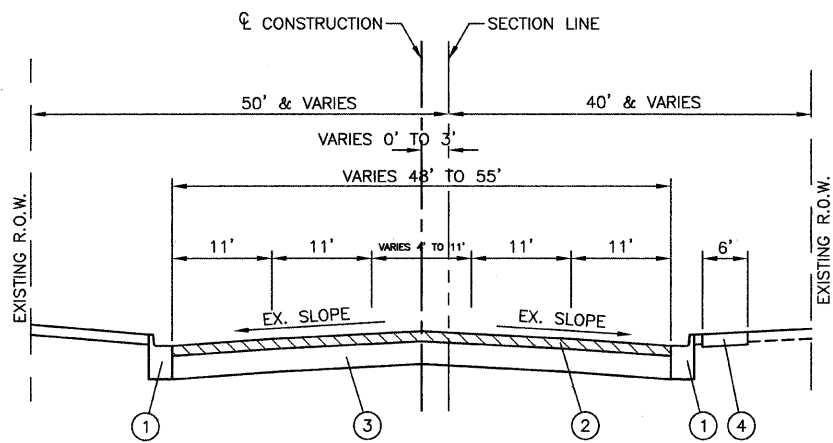

EXISTING TYPICAL CROSS SECTION

135TH STREET
STA 10+32.55 TO STA 14+83.29

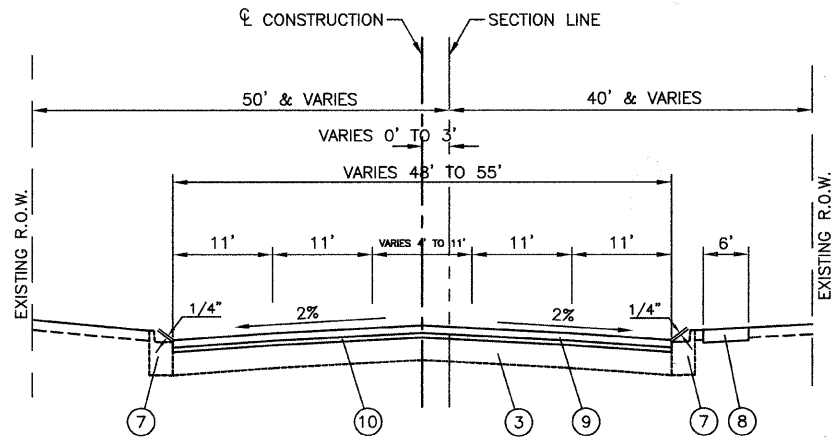

PROPOSED TYPICAL CROSS SECTION

135TH STREET
STA 10+32.55 TO STA 14+83.29

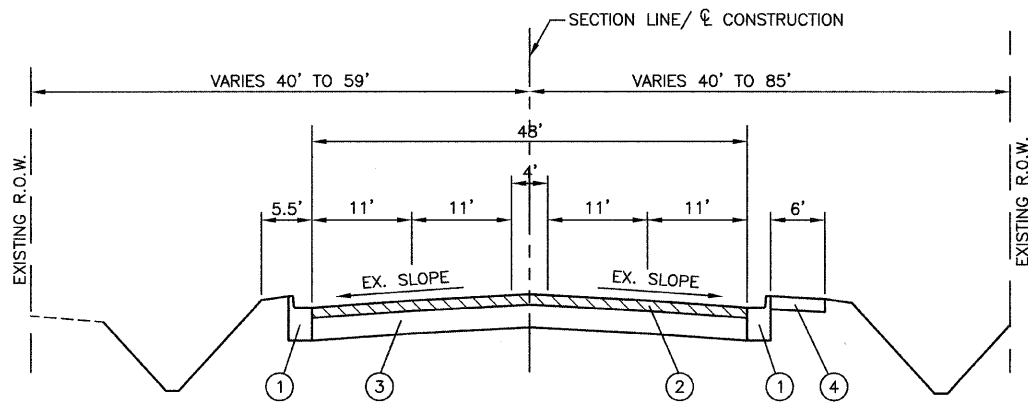

EXISTING TYPICAL CROSS SECTION

135TH STREET
STA 14+83.29 TO STA 24+57.60

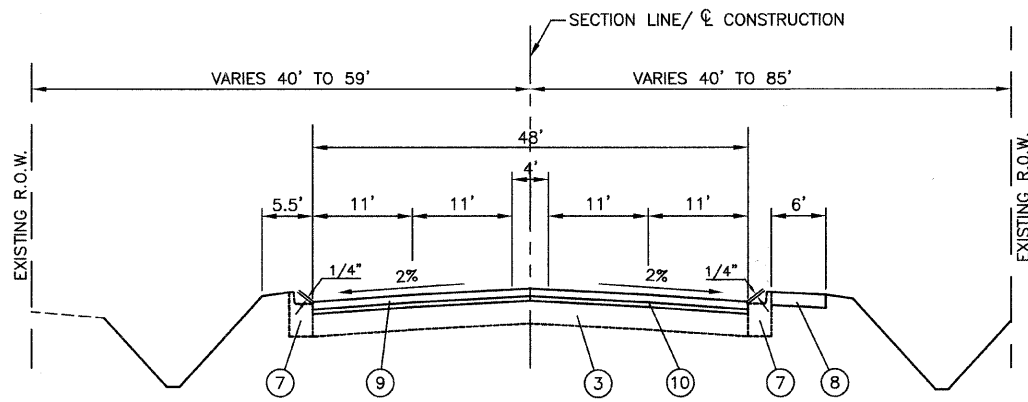

PROPOSED TYPICAL CROSS SECTION

135TH STREET
STA 14+83.29 TO STA 24+57.60

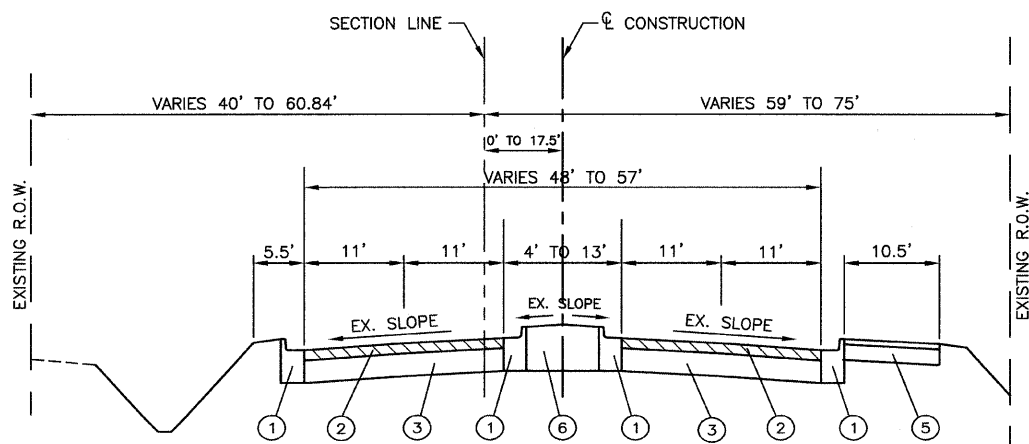

EXISTING TYPICAL CROSS SECTION

135TH STREET
STA 24+57.60 TO STA 59+18.53
(EXCLUDING STRUCTURES)

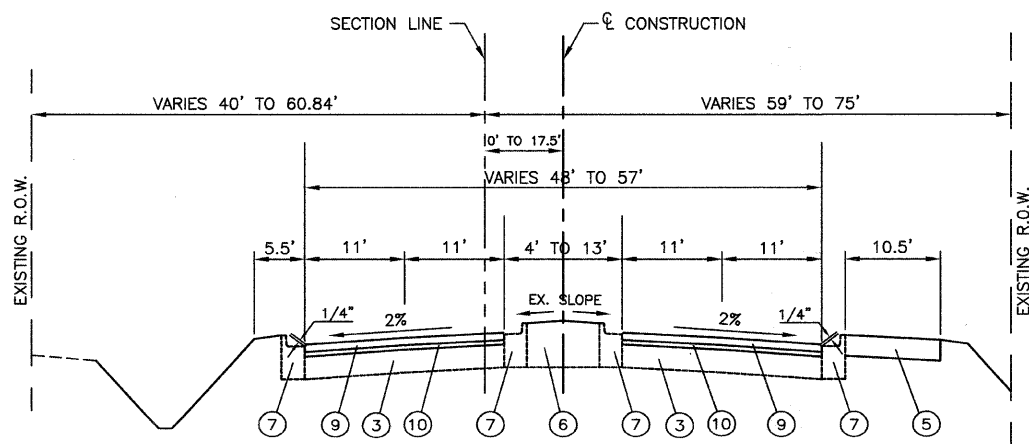

PROPOSED TYPICAL CROSS SECTION

135TH STREET
STA 24+57.60 TO STA 59+18.53
(EXCLUDING STRUCTURES)

LEGEND

- ① EXISTING CURB & GUTTER TO BE REMOVED AT LOCATIONS SHOWN ON PLANS OR DIRECTED BY ENGINEER
- ② HOT-MIX ASPHALT SURFACE REMOVAL, 2"
- ③ EXISTING HOT-MIX ASPHALT BASE COURSE TO REMAIN, ±9"
- ④ EXISTING PC CONCRETE SIDEWALK TO BE REMOVED AT LOCATIONS SHOWN ON PLANS OR DIRECTED BY ENGINEER
- ⑤ EXISTING HOT-MIX ASPHALT BIKE PATH TO REMAIN
- ⑥ EXISTING HOT-MIX ASPHALT MEDIAN TO REMAIN
- ⑦ COMBINATION CURB & GUTTER, B-6.24, AT LOCATIONS SHOWN ON PLANS OR DIRECTED BY ENGINEER
- ⑧ PC CONCRETE SIDEWALK, 5" AT LOCATIONS SHOWN ON PLANS OR DIRECTED BY ENGINEER
- ⑨ HOT-MIX ASPHALT SURFACE COURSE, MIX "D", N70, 1 1/2"
- ⑩ POLYMERIZED LEVELING BINDER (MACHINE METHOD), IL-4.75, N50, 3/4"

HOT-MIX ASPHALT MIXTURE REQUIREMENTS

(CONTRACTOR SHALL MILL BEFORE PATCHING)

MIXTURE TYPE	AIR VOIDS % Ndes
RESURFACING	
HOT-MIX ASPHALT SURFACE COURSE, MIX "D", N70 (IL-9.5 mm): 1 1/2"	4% @ 70 Gyr.
POLYMERIZED LEVELING BINDER (MACHINE METHOD), IL-4.75, N50, 3/4"	4% @ 50 Gyr.
DRIVEWAYS	
HOT-MIX ASPHALT SURFACE COURSE, MIX "C", N50 (IL-9.5mm): 2"	4% @ 50 Gyr.
HOT-MIX ASPHALT BASE COURSE, (HMA BINDER IL-19.0mm): 6"	4% @ 50 Gyr.
PATCHING	
CLASS D PATCHES, TYPE III, IV, (HMA BINDER IL-19.0mm): 9"	4% @ 70 Gyr.

THE UNIT WEIGHT USED TO CALCULATE ALL HMA SURFACE MIXTURE QUANTITIES IS 112 LBS/SQ YD/IN. THE "AC TYPE" FOR POLYMERIZED HMA MIXES SHALL BE "SBS/SBR PG 70-22" AND FOR NON-POLYMERIZED HMA THE "AC TYPE" SHALL BE "PG 64-22" UNLESS MODIFIED BY DISTRICT ONE SPECIAL PROVISIONS. FOR "PERCENT OF RAP" SEE DISTRICT ONE SPECIAL PROVISIONS.

NOTE:
CLASS D PATCHES, TYPE III & IV AT APPROXIMATE STATIONS AS SHOWN ON THE PLANS OR AS DIRECTED BY THE ENGINEER.

FILE NAME = 09275-TYPX-01 - TYPX P01

USER NAME =	DESIGNED -- JRD	REVISED --
	CHECKED -- HLG	REVISED --
PLOT SCALE =	DRAWN -- LTL	REVISED --
PLOT DATE = 08-07-09	CHECKED -- HLG	REVISED --

STATE OF ILLINOIS
DEPARTMENT OF TRANSPORTATION

135TH STREET RESURFACING		
IL-53 TO SANITARY & SHIP CANAL BRIDGE		
TYPICAL CROSS SECTIONS		
SCALE: NONE	SHEET NO. 3 OF 11 SHEETS	STA. TO STA.

F.A.U. RITE	SECTION	COUNTY	TOTAL SHEETS	SHEET NO.
0282	09-00063-00-RS	WILL	11	3
CONTRACT NO. 63264				
FED. ROAD DIST. NO. 1 ILLINOIS FED. AID PROJECT ARA-9003-(361)				

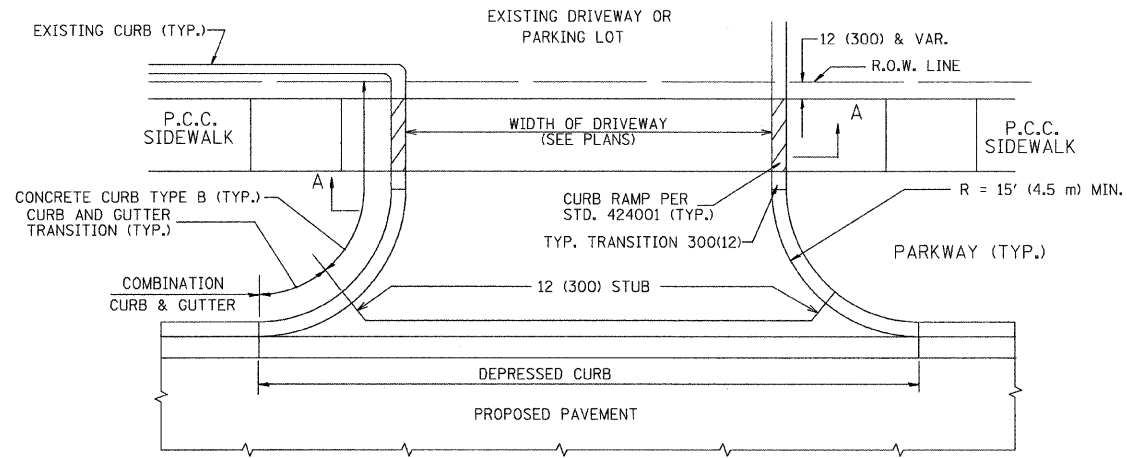

WITH CONCRETE CURB, TYPE B

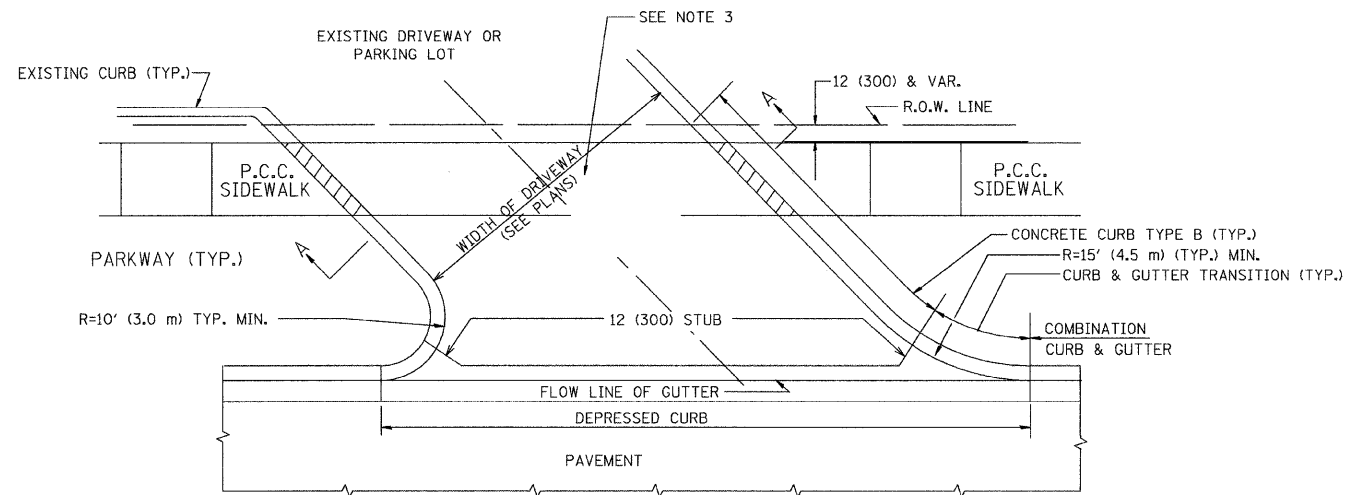

WITH CONCRETE CURB, TYPE B

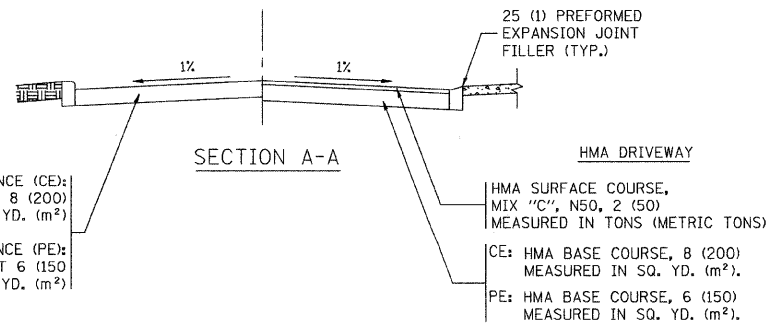

RIGID DRIVEWAY
 COMMERCIAL ENTRANCE (CE):
 P.C.C. DRIVEWAY PAVEMENT 8 (200)
 MEASURED IN SQ. YD. (m²)
 NON-COMMERCIAL ENTRANCE (PE):
 P.C.C. DRIVEWAY PAVEMENT 6 (150)
 MEASURED IN SQ. YD. (m²)

HMA DRIVEWAY
 HMA SURFACE COURSE,
 MIX "C", N50, 2 (50)
 MEASURED IN TONS (METRIC TONS)
 CE: HMA BASE COURSE, 8 (200)
 MEASURED IN SQ. YD. (m²).
 PE: HMA BASE COURSE, 6 (150)
 MEASURED IN SQ. YD. (m²).

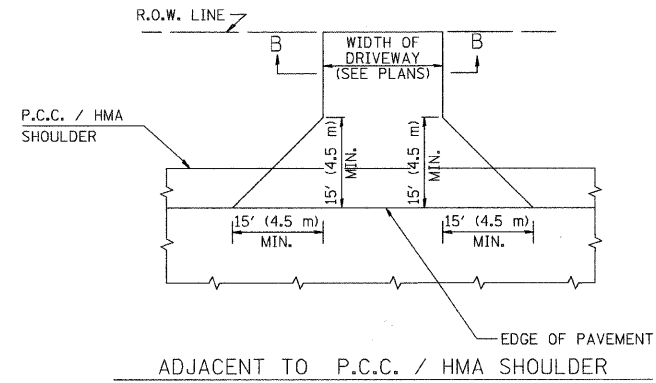

ADJACENT TO P.C.C. / HMA SHOULDER

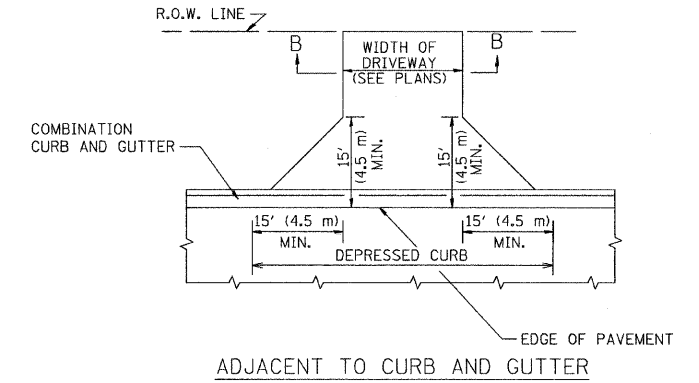

ADJACENT TO CURB AND GUTTER

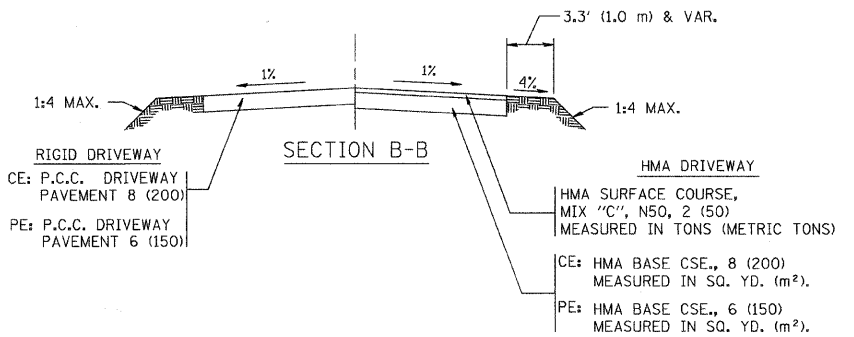

RURAL FIELD ENTRANCE (FE)

HMA SURFACE COURSE,
 MIX "C", N50, 2 (50)
 MEASURED IN TONS (METRIC TONS)
 CE: HMA BASE CSE., 8 (200)
 MEASURED IN SQ. YD. (m²).
 PE: HMA BASE CSE., 6 (150)
 MEASURED IN SQ. YD. (m²).

GENERAL NOTES:

DRIVEWAY SLOPES, LOCATIONS, & GEOMETRIC LAYOUT SHALL BE IN ACCORDANCE WITH THE LATEST EDITION OF THE "HANDBOOK FOR POLICY ON PERMITS FOR ACCESS DRIVEWAYS TO STATE HIGHWAYS". FOR FURTHER LAYOUT REQUIREMENTS, REFER TO ILLUSTRATIONS IN THE PERMIT HANDBOOK. DRIVEWAYS SHALL BE REPLACED IN KIND, UNLESS OTHERWISE NOTED ON THE PLANS.

COMMERCIAL DRIVEWAYS SHALL BE CONSTRUCTED WITH CONCRETE CURB, TYPE B RETURNS EXCEPT WHEN THE SIDEWALK EDGE IS 4 FEET (1.2 METERS) OR LESS FROM THE BACK OF CURB, CONSTRUCT A FLARE DRIVEWAY WITHOUT CURB.

THE RESIDENT ENGINEER SHALL CONTACT THE TRAFFIC PERMIT OFFICE AT 847/ 705-4131 FOR ANY QUESTIONS ON DRIVEWAYS SHOWN IN THE PLANS; SPECIFICALLY IN REFERENCE TO ADDITIONAL AND/OR RELOCATION/REMOVAL OF A DRIVEWAY.

COMBINATION CONCRETE CURB & GUTTER SHALL BE MEASURED STRAIGHT ACROSS THE DRIVEWAY. NO ADDITIONAL COMPENSATION WILL BE ALLOWED FOR THE CURB & GUTTER TRANSITION.

1 (25) PREFORMED EXPANSION JOINT FILLER WILL NOT BE PAID SEPARATELY, BUT SHALL BE CONSIDERED INCLUDED IN THE COST OF THE P.C.C. DRIVEWAY PAVEMENT OR P.C.C. SIDEWALK.

WHEN THE P.C.C. SIDEWALK EXTENDS THROUGH THE DRIVEWAY, THE THICKNESS OF THE SIDEWALK IN THE DRIVEWAY AREA SHALL BE THE SAME AS THE DRIVEWAY THICKNESS. SIDEWALK WILL BE PAID FOR AS P.C.C. SIDEWALK OF THE THICKNESS SPECIFIED. SIDEWALK CROSS SLOPE THRU DRIVEWAY AREA TO BE A MAXIMUM OF 1:50.

FILE NAME = c:\projects\dstatd22x34\bd01.dgn	USER NAME = bauer-dl	DESIGNED - R. SHAH	REVISED - M. GOMEZ 04-06-01	STATE OF ILLINOIS DEPARTMENT OF TRANSPORTATION	DISTRICT ONE DRIVEWAY DETAILS - DISTANCE BETWEEN R.O.W. AND FACE OF CURB & EDGE OF SHOULDER >= 15'(4.5m)		F.A.U. RTE. 0282	SECTION 09-00053-00-RS	COUNTY WILL	TOTAL SHEETS 11	SHEET NO. 6	
PLOT SCALE = 49.9999 "/> <td>CHECKED -</td> <td>REVISED - R. BORO 01-01-07</td> <td>SCALE: NONE</td> <td>SHEET NO. 6</td> <td>OF 11 SHEETS</td> <td>STA.</td> <td>TO STA.</td> <td colspan="4" style="text-align: center;">CONTRACT NO. 63264</td>	CHECKED -	REVISED - R. BORO 01-01-07	SCALE: NONE		SHEET NO. 6	OF 11 SHEETS	STA.	TO STA.	CONTRACT NO. 63264			
PLOT DATE = 6/12/2008	DATE - 11-04-95	REVISED - R. BORO 06-11-08					FED. ROAD DIST. NO. 1 ILLINOIS FED. AID PROJECT ARA-9003-(361)					
BD0156-07 (BD-01)												

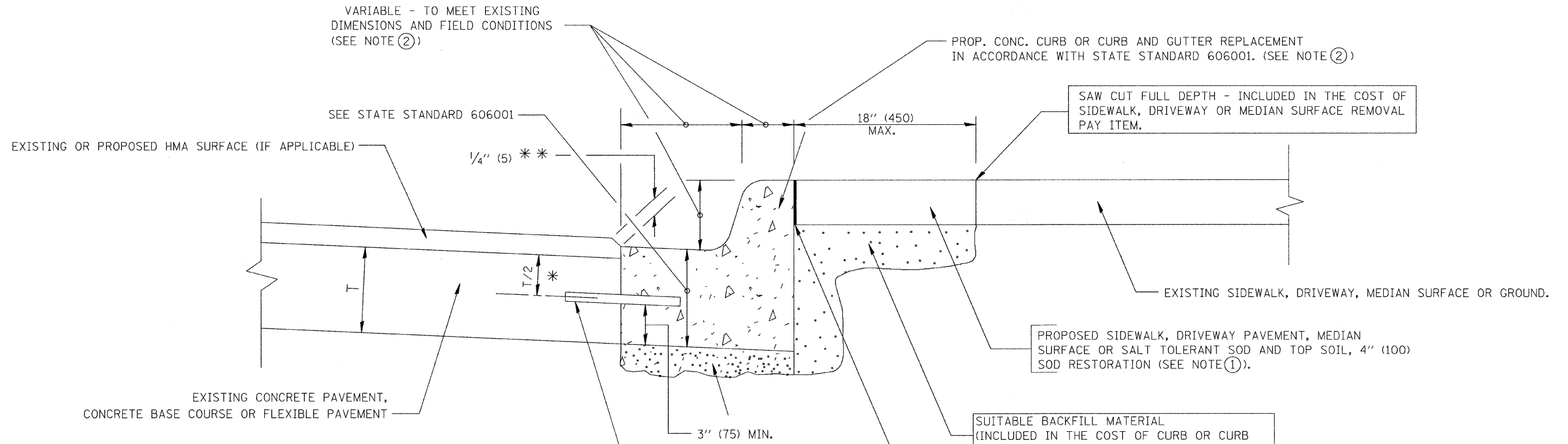

* 3" (75) MINIMUM FROM TOP AND BOTTOM OF THE CONCRETE PAVEMENT OR BASE COURSE.

** IF THE FINAL SURFACE OF THE PAVEMENT IS CONCRETE, THE GUTTER IS TO BE FLUSH WITH THE PAVEMENT.

NOTE: ① SIDEWALK, DRIVEWAY PAVEMENT OR MEDIAN SURFACE SHALL BE SIMILAR TO THE MATERIAL BEING REMOVED AND WILL BE PAID FOR SEPARATELY.

SALT TOLERANT SOD AND TOP SOIL, 4" (100) RESTORATION WILL NOT BE PAID FOR SEPARATELY, BUT SHALL BE INCLUDED IN THE COST OF CURB OR CURB AND GUTTER REMOVAL AND REPLACEMENT.

② CURB OR CURB AND GUTTER REPLACEMENT SHALL MATCH THE SHAPE OF THE EXISTING CURB OR CURB AND GUTTER UNLESS OTHERWISE SPECIFIED.

③ FOR CURB OR CURB AND GUTTER REMOVAL AND REPLACEMENT ADJACENT TO FLEXIBLE PAVEMENT DELETE EPOXY COATED TIE BARS.

④ LONGITUDINAL BARS, IF ENCOUNTERED IN THE EXISTING CURB OR CURB AND GUTTER, ARE NOT TO BE REPLACED. CUTTING AND REMOVING LONGITUDINAL BARS SHALL BE INCLUDED IN THE COST OF CURB OR CURB AND GUTTER REMOVAL AND REPLACEMENT.

⑤ THE COST OF HMA SURFACE REMOVAL IN THE EXISTING GUTTER FLAG SHALL BE INCLUDED IN THE COST OF THE CURB AND GUTTER REMOVAL AND REPLACEMENT.

⑥ THE REMOVAL AND REPLACEMENT OF THE EXISTING CURB OR CURB AND GUTTER SHALL BE DONE IN ACCORDANCE WITH THE APPLICABLE PORTIONS OF SECTION 440 AND 606 OF THE STANDARD SPECIFICATIONS.

⑦ THE LOCATIONS OF REMOVAL AND REPLACEMENT OF EXISTING CURB OR CURB AND GUTTER SHALL BE DETERMINED BY THE RESIDENT ENGINEER AT THE TIME OF CONSTRUCTION.

BASIS OF PAYMENT:

THIS WORK WILL BE PAID FOR AT THE CONTRACT UNIT PRICE PER FOOT (METER) FOR "CURB REMOVAL AND REPLACEMENT" OR "COMBINATION CONCRETE CURB AND GUTTER REMOVAL AND REPLACEMENT".

CURB OR CURB AND GUTTER REMOVAL AND REPLACEMENT

ALL DIMENSIONS ARE IN INCHES (MILLIMETERS) UNLESS OTHERWISE SHOWN.

FILE NAME =	USER NAME = geglentobt	DESIGNED - A. HOUSEH	REVISED - R. SHAH 10-03-96
W:\diststd\22x34\bd24.dgn		DRAWN -	REVISED - A. ABBAS 03-21-97

STATE OF ILLINOIS
DEPARTMENT OF TRANSPORTATION

DISTRICT ONE
CURB OR CURB AND GUTTER
REMOVAL AND REPLACEMENT

SCALE: NONE SHEET NO. 7 OF 11 SHEETS STA. TO STA.

F.A.U. RTE.	SECTION	COUNTY	TOTAL SHEETS	SHEET NO.
0282	09-00053-00-RS	WILL	11	7
80600-06 (80-24)			CONTRACT NO. 63264	
FED. ROAD DIST. NO. 1		ILLINOIS	FED. AID PROJECT ARA-9003-(361)	

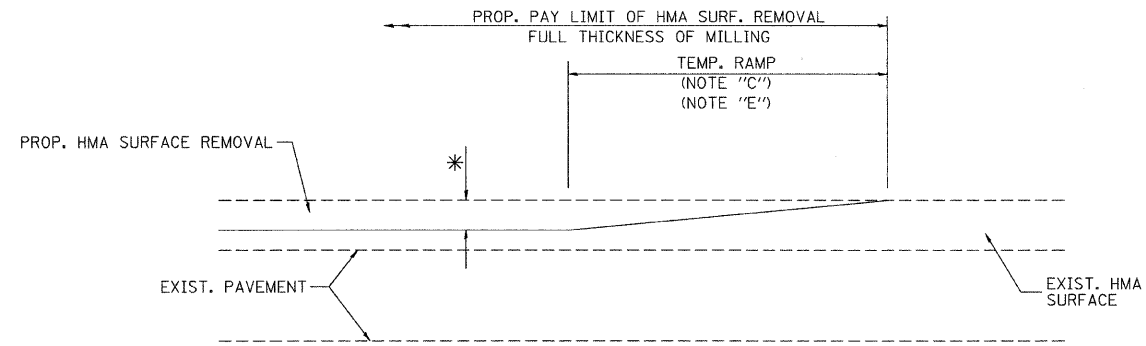

MILLED TEMPORARY RAMP
(FOR BUTT JOINT AND HMA TAPER SEE DETAIL BELOW)

OPTION 1

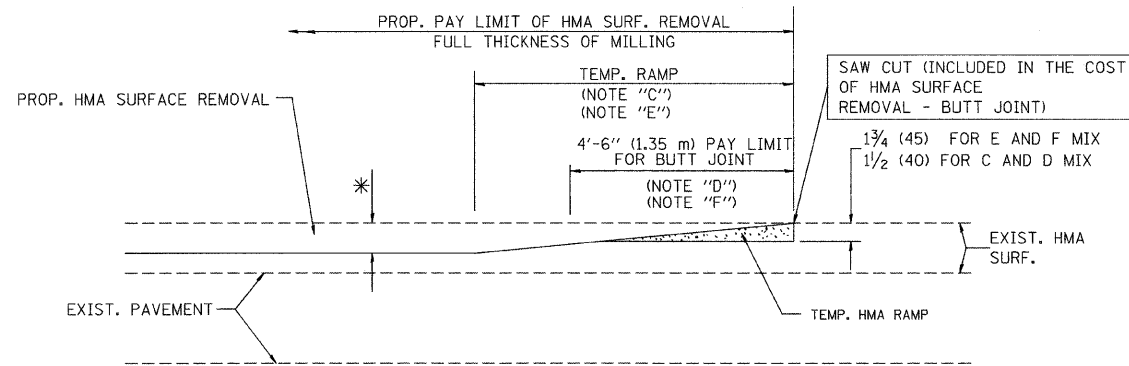

HMA CONSTRUCTED TEMPORARY RAMP
(FOR BUTT JOINT AND HMA TAPER SEE DETAIL BELOW)

OPTION 2

TYPICAL TEMPORARY RAMP

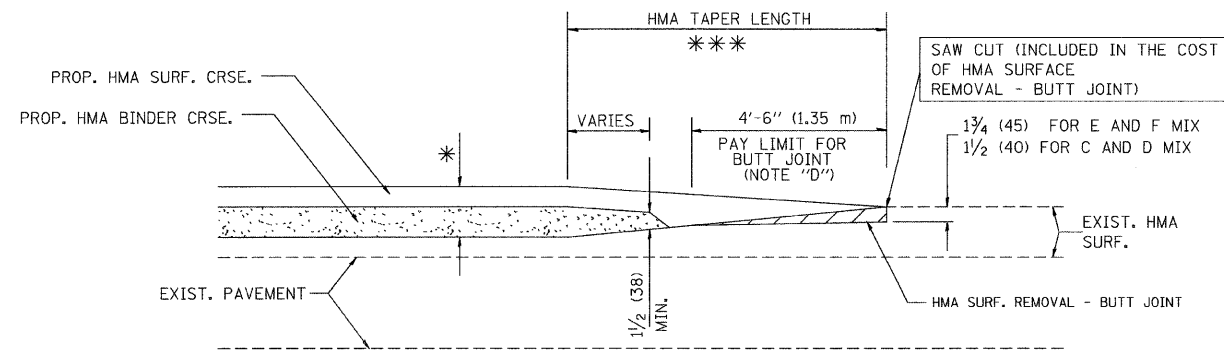

BUTT JOINT AND HMA TAPER

TYPICAL BUTT JOINT AND HMA TAPER
FOR MILLING AND RESURFACING

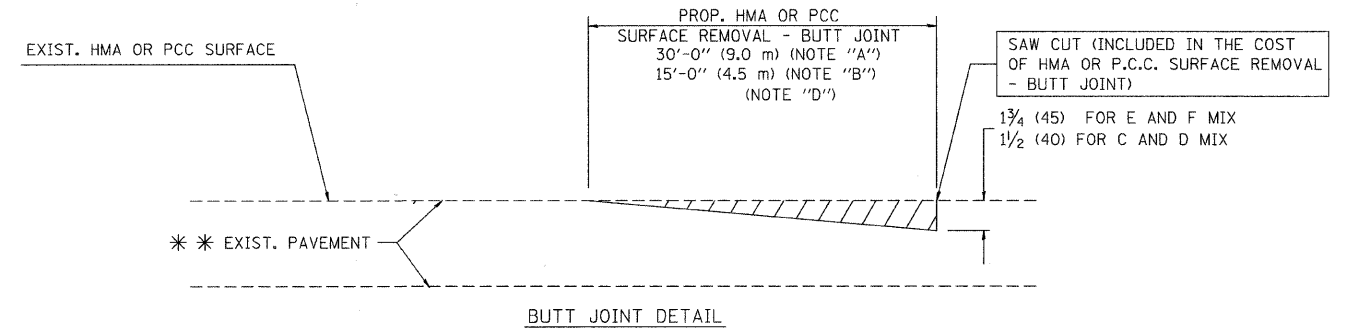

BUTT JOINT DETAIL

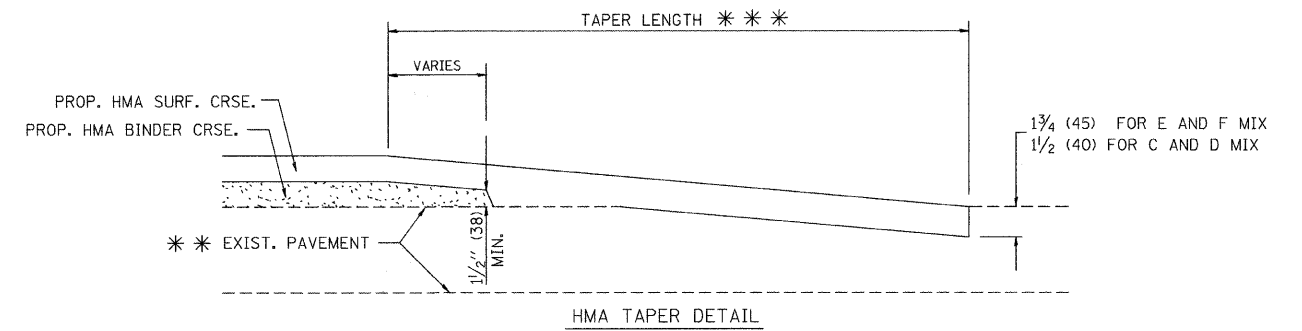

HMA TAPER DETAIL

TYPICAL BUTT JOINT AND HMA TAPER
FOR RESURFACING ONLY

*** PC CONCRETE, HMA OR HMA RESURFACED PAVEMENT.

NOTES

- A: MAINLINE ROADWAYS AND MAJOR SIDE ROADS.
- B: MINOR SIDE ROADS.
- C: THE TEMP. RAMP SHALL BE CONSTRUCTED IMMEDIATELY UPON REMOVAL OF THE EXISTING HMA SURFACE.
- D: THE BUTT JOINT SHALL BE CONSTRUCTED IMMEDIATELY PRIOR TO PLACING THE PROPOSED HMA COURSES.
- E: TAPER THE TEMP. RAMP AT A RATE OF 3'-0" (900 mm) PER 1 INCH (25 mm) OF MILLING THICKNESS.
- F: INSTALLATION AND REMOVAL OF THE 4'-6" (1.35 m) TEMP. RAMP IS INCLUDED IN COST OF HMA SURFACE REMOVAL - BUTT JOINT
- G: SEE ARTICLE 406.08 AND 406.14 OF THE STANDARD SPECIFICATIONS FOR "HMA AND/OR PCC SURFACE REMOVAL, BUTT JOINT".
- * SEE TYPICAL SECTIONS FOR MILLING THICKNESS.
- *** 20'-0" (6.1 m) PER 1 (25) RESURFACING (NOTE "A")
10'-0" (3.0 m) PER 1 (25) RESURFACING (NOTE "B")

BASIS OF PAYMENT:

THE BUTT JOINT WILL BE PAID FOR AT THE CONTRACT UNIT PRICE PER SQUARE YARD (SQUARE METER) FOR "HOT-MIX ASPHALT SURFACE REMOVAL - BUTT JOINT" OR FOR "PORTLAND CEMENT CONCRETE SURFACE REMOVAL - BUTT JOINT".

ALL DIMENSIONS ARE IN INCHES (MILLIMETERS) UNLESS OTHERWISE SHOWN.

FILE NAME = W:\diststd\22x34\bd32.dgn	USER NAME = geglanoht	DESIGNED - M. DE YONG	REVISED - R. SHAH 10-25-94	STATE OF ILLINOIS DEPARTMENT OF TRANSPORTATION	DISTRICT ONE BUTT JOINT AND HMA TAPER DETAILS		F.A.U. RTE. 0282	SECTION 09-0053-00-RS	COUNTY WILL	TOTAL SHEETS 11	SHEET NO. 8		
PLOT SCALE = 50.0000' / IN.	CHECKED -	DRAWN -	REVISED - A. ABBAS 03-21-97		SCALE: NONE	SHEET NO. 8	OF 11 SHEETS	STA.	TO STA.	CONTRACT NO. 63264			
PLOT DATE = 1/4/2008	DATE - 06-13-90	CHECKED -	REVISED - M. GOMEZ 04-06-01					FED. ROAD DIST. NO. 1			ILLINOIS		FED. AID PROJECT ARA-9003-(361)
		DATE - 06-13-90	REVISED - R. BORO 01-01-07										

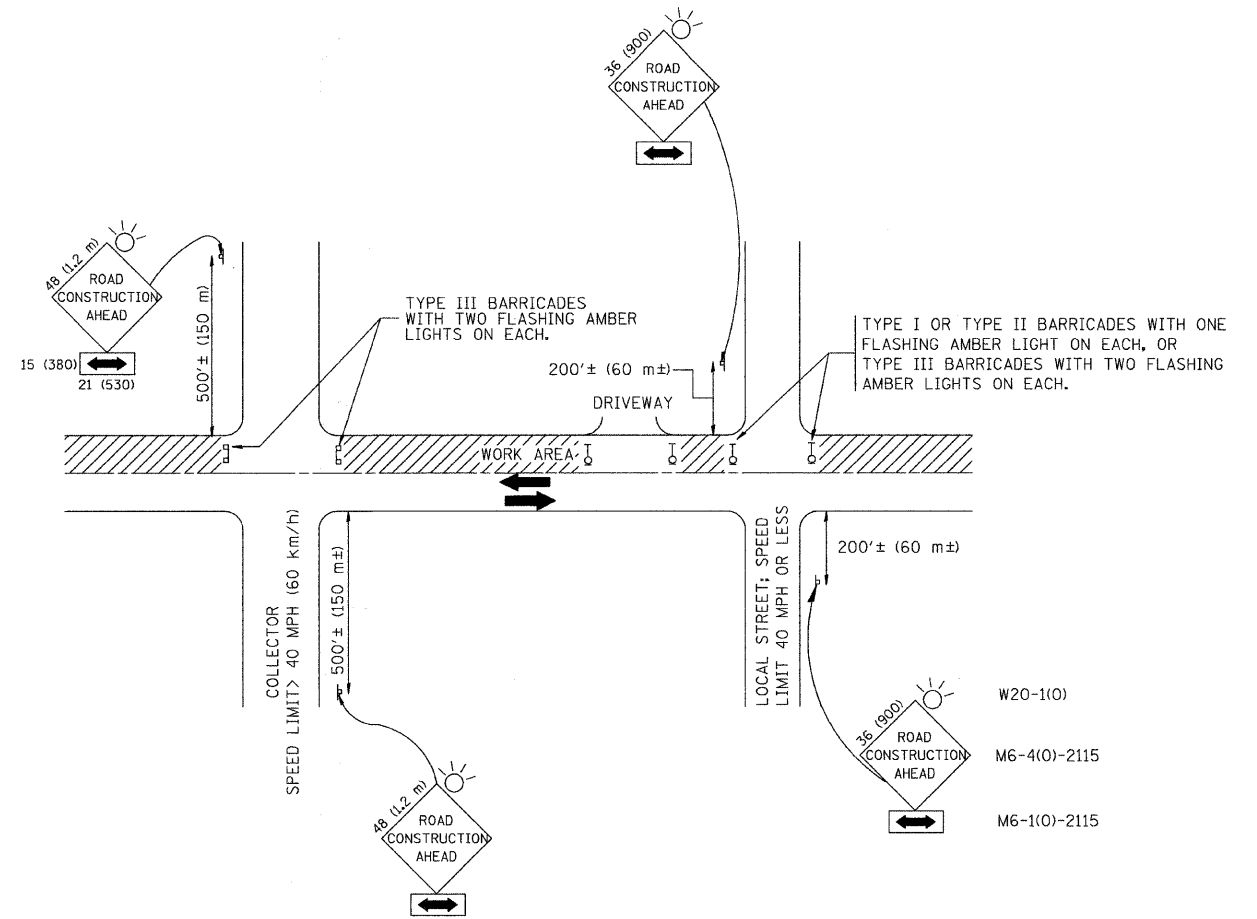

TRAFFIC CONTROL AND PROTECTION FOR SIDE ROADS, INTERSECTIONS, AND DRIVEWAYS

NOTES:

- A. FOR NO LANE RESTRICTION ON THE SIDE ROAD OR DRIVEWAYS
 1. SIDE ROAD WITH A SPEED LIMIT OF 40 MPH (60 km/h) OR LESS AS SHOWN ON THE DRAWING AND AS DIRECTED BY THE ENGINEER:
 - a) ONE **ROAD CONSTRUCTION AHEAD** SIGN 36 x 36 (900x900) WITH A FLASHER AND FLAG MOUNTED ON IT APPROXIMATELY 200' (60 m) IN ADVANCE OF THE MAIN ROUTE.
 - b) THE CLOSED PORTION OF THE MAIN ROUTE SHALL BE PROTECTED BY BLOCKING WITH TYPE I, TYPE II OR TYPE III BARRICADES, 1/3 OF THE CROSS SECTION OF THE CLOSED PORTION.
 2. SIDE ROAD WITH A SPEED LIMIT GREATER THAN 40 MPH (60 km/h) AS SHOWN ON THE DRAWING AND AS DIRECTED BY THE ENGINEER:
 - a) ONE **ROAD CONSTRUCTION AHEAD** SIGN 48 x 48 (1.2 m x 1.2 m) WITH A FLASHER MOUNTED ON IT APPROXIMATELY 500' (150 m) IN ADVANCE OF THE MAIN ROUTE.
 - b) THE CLOSED PORTION OF THE MAIN ROUTE SHALL BE PROTECTED BY BLOCKING WITH TYPE III BARRICADES, 1/2 OF THE CROSS SECTION OF THE CLOSED PORTION.
 3. WHEN THE SIDE ROAD LIES BETWEEN THE BEGINNING OF THE MAINLINE SIGNING AND THE WORK ZONE, A SINGLE HEADED ARROW (M6-1) SHALL BE USED IN LIEU OF THE DOUBLE HEADED ARROW (M6-4).
- B. FOR A LANE CLOSURE ON A SIDE ROAD OR DRIVEWAY:

USE APPLICABLE PORTIONS OF THE TYPICAL APPLICATION OF TRAFFIC CONTROL DEVICES (STD. 701501, STD. 701606 OR THE APPROPRIATE STANDARD). THE SPACING OF SIGNS AND BARRICADES SHALL BE ADJUSTED FOR FIELD CONDITIONS AS DIRECTED BY THE ENGINEER. THE DIRECTIONAL ARROW SHALL BE COVERED OR REMOVED WHEN NO LONGER CONSISTENT WITH THE SIDE ROAD LANE CLOSURE.
- C. ADVANCE WARNING SIGNS ARE TO BE OMITTED ON DRIVEWAY UNLESS OTHERWISE NOTED.
- D. THE TRAFFIC CONTROL AND PROTECTION FOR SIDE ROADS, INTERSECTIONS, AND DRIVEWAYS SHALL BE INCIDENTAL TO THE COST OF SPECIFIED TRAFFIC CONTROL STANDARDS OR ITEMS.

All dimensions are in millimeters (inches) unless otherwise shown.

FILE NAME = W:\diststd\22x34\to10.dgn	USER NAME = geglianobt	DESIGNED - LHA	REVISED - J. OBERLE 10-18-95
		DRAWN -	REVISED - A. HOUSEH 03-06-96
	PLOT SCALE = 50.0000' / IN.	CHECKED -	REVISED - A. HOUSEH 10-15-96
	PLOT DATE = 1/4/2008	DATE - 06-89	REVISED - T. RAMMACHER 01-06-00

STATE OF ILLINOIS
DEPARTMENT OF TRANSPORTATION

DISTRICT ONE			
TRAFFIC CONTROL AND PROTECTION FOR			
SIDE ROADS, INTERSECTIONS, AND DRIVEWAYS			
SCALE: NONE	SHEET NO. 9	OF 11 SHEETS	STA. TO STA.

F.A.U. RTE.	SECTION	COUNTY	TOTAL SHEETS	SHEET NO.
0282	09-00053-00-RS	WILL	11	9
TC-10			CONTRACT NO. 63264	
FED. ROAD DIST. NO. 1		ILLINOIS	FED. AID PROJECT ARA-9003-(361)	

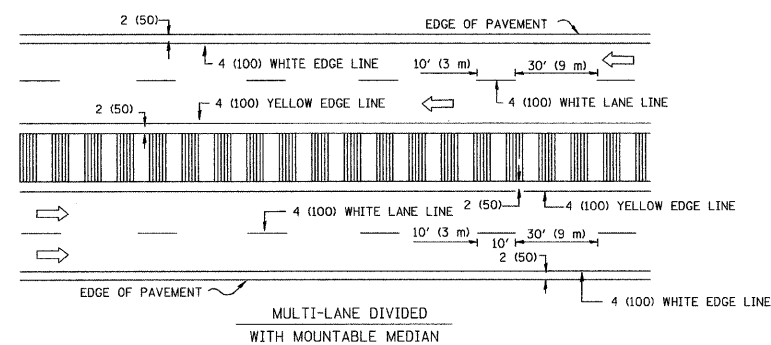
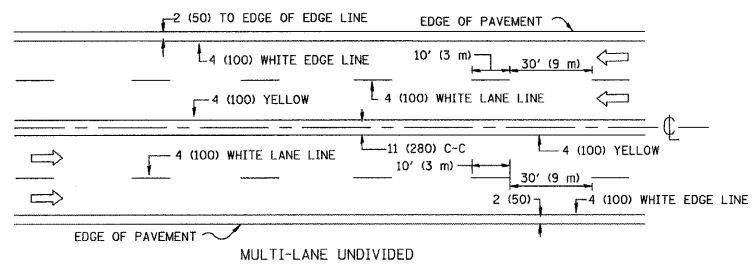
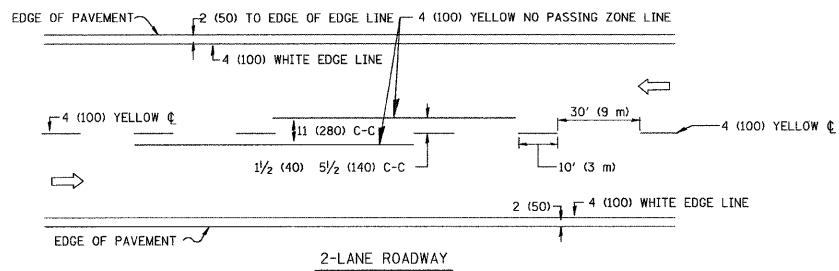

NOTE: MEDIANS WITH BARRIER CURB DO NOT REQUIRE AN EDGE LINE

TYPICAL LANE AND EDGE LINE MARKING

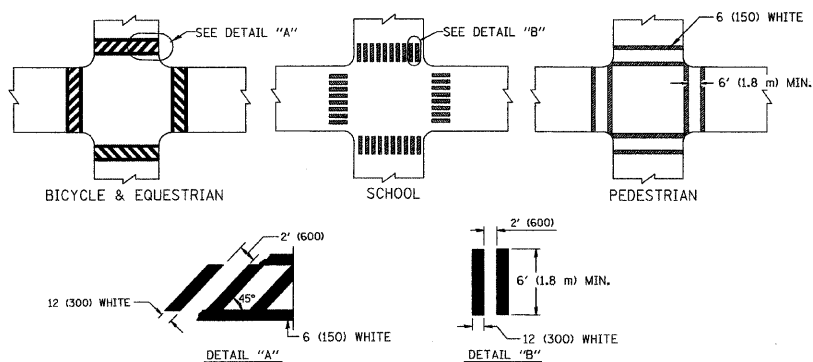

TYPICAL CROSSWALK MARKING

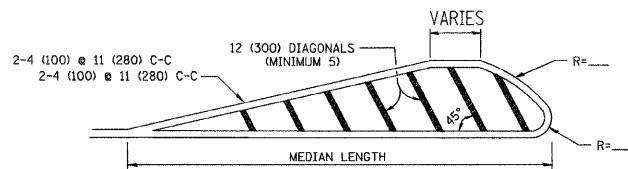
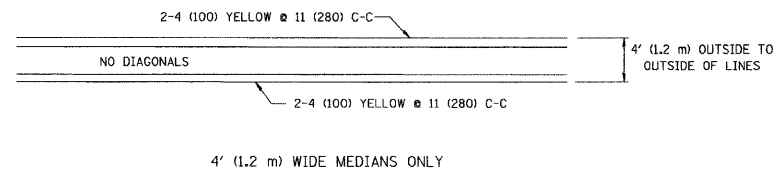

FOR MEDIAN LENGTHS WHERE DIAGONAL SPACING CANNOT BE ATTAINED, USE 5 (FIVE) EQUALLY SPACED DIAGONAL LINES.
 DIAGONAL LINE SPACING: 50' (15 m) C-C (LESS THAN 30MPH (50 km/h))
 75' (25 m) C-C 30MPH (50 km/h) TO 45MPH (70 km/h)
 150' (45 m) C-C (MORE THAN 45MPH (70 km/h))

MEDIANS OVER 4' (1.2 m) WIDE

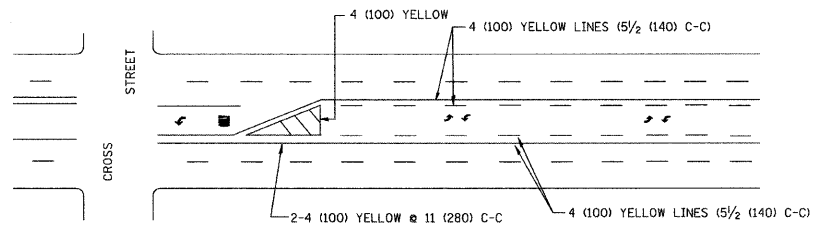

A MINIMUM OF TWO PAIRS OF TURN ARROWS SHALL BE USED, WHITE IN COLOR. ADDITIONAL PAIRS SHALL BE PLACED AT 200' (60 m) TO 300' (90 m) INTERVALS.

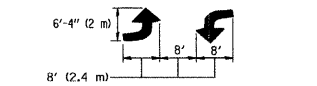

MEDIAN WITH TWO-WAY LEFT TURN LANE

TYPICAL PAINTED MEDIAN MARKING

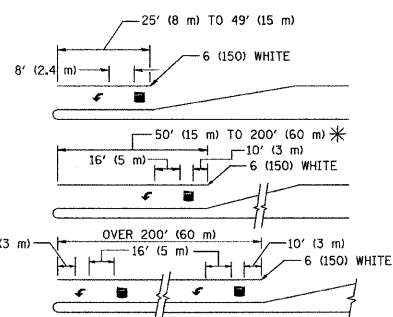

FULL SIZE LETTERS 8' (2.4 m) AND ARROWS SHALL BE USED.
 AREA = 15.6 SQ. FT. (1.5 m²) AREA = 20.8 SQ. FT. (1.9 m²)

* TURN LANES IN EXCESS OF 400' (120 m) IN LENGTH MAY HAVE AN ADDITIONAL SET OF ARROW - "ONLY" INSTALLED MIDWAY BETWEEN THE OTHER TWO SETS OF ARROW - "ONLY".

TYPICAL LEFT (OR RIGHT) TURN LANE

TYPICAL TURN LANE MARKING

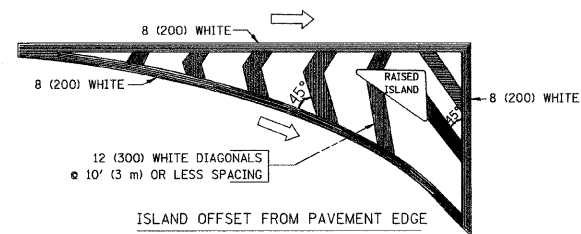

ISLAND OFFSET FROM PAVEMENT EDGE

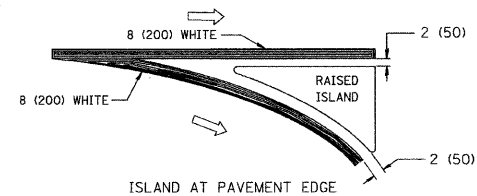

ISLAND AT PAVEMENT EDGE

TYPICAL ISLAND MARKING

TYPE OF MARKING	WIDTH OF LINE	PATTERN	COLOR	SPACING / REMARKS
CENTERLINE ON 2 LANE PAVEMENT	4 (100)	SKIP-DASH	YELLOW	10' (3 m) LINE WITH 30' (9 m) SPACE
CENTERLINE ON MULTI-LANE UNDIVIDED PAVEMENT	2 @ 4 (100)	SOLID	YELLOW	11 (280) C-C
NO PASSING ZONE LINES: FOR ONE DIRECTION FOR BOTH DIRECTIONS	4 (100) 2 @ 4 (100)	SOLID SOLID	YELLOW YELLOW	5/2 (140) C-C FROM SKIP-DASH CENTERLINE 11 (280) C-C OMIT SKIP-DASH CENTERLINE BETWEEN
LANE LINES	4 (100) 5 (125) ON FREEWAYS	SKIP-DASH SKIP-DASH	WHITE WHITE	10' (3 m) LINE WITH 30' (9 m) SPACE
DOTTED LINES (EXTENSIONS OF CENTER, LANE OR TURN LANE MARKINGS)	SAME AS LINE BEING EXTENDED	SKIP-DASH	SAME AS LINE BEING EXTENDED	2' (600) LINE WITH 6' (1.8 m) SPACE
EDGE LINES	4 (100)	SOLID	YELLOW-LEFT WHITE-RIGHT	OUTLINE MOUNTABLE MEDIANS IN YELLOW; EDGE LINES ARE NOT USED NEXT TO BARRIER CURB
TURN LANE MARKINGS	6 (150) LINE; FULL SIZE LETTERS & SYMBOLS (8' (2.4m))	SOLID	WHITE	SEE TYPICAL TURN LANE MARKING DETAIL
TWO WAY LEFT TURN MARKING	2 @ 4 (100) EACH DIRECTION 8' (2.4m) LEFT ARROW	SKIP-DASH AND SOLID IN PAIRS	YELLOW WHITE	10' (3 m) LINE WITH 30' (9 m) SPACE FOR SKIP-DASH; 5/2 (140) C-C BETWEEN SOLID LINE AND SKIP-DASH LINE SEE TYPICAL TWO-WAY LEFT TURN MARKING DETAIL
CROSSWALK LINES (PEDESTRIAN) A. DIAGONALS (BIKE & EQUESTRIAN) B. LONGITUDINAL BARS (SCHOOL)	2 @ 6 (150) 12 (300) @ 45° 12 (300) @ 90°	SOLID SOLID SOLID	WHITE WHITE WHITE	NOT LESS THAN 6' (1.8 m) APART 2' (600) APART 2' (600) APART SEE TYPICAL CROSSWALK MARKING DETAILS.
STOP LINES	24 (600)	SOLID	WHITE	PLACE 4' (1.2 m) IN ADVANCE OF AND PARALLEL TO CROSSWALK, IF PRESENT. OTHERWISE, PLACE AT DESIRED STOPPING POINT. PARALLEL TO CROSSROAD CENTERLINE, WHERE POSSIBLE
PAINTED MEDIANS	2 @ 4 (100) WITH 12 (300) DIAGONALS @ 45° NO DIAGONALS USED FOR 4' (1.2 m) WIDE MEDIANS	SOLID	YELLOW; TWO WAY TRAFFIC WHITE; ONE WAY TRAFFIC	11 (280) C-C FOR THE DOUBLE LINE SEE TYPICAL PAINTED MEDIAN MARKING.
GORE MARKING AND CHANNELIZING LINES	8 (200) WITH 12 (300) DIAGONALS @ 45°	SOLID	WHITE	DIAGONALS: 15' (4.5 m) C-C (LESS THAN 30MPH (50 km/h)) 20' (6 m) C-C 30MPH (50 km/h) TO 45MPH (70 km/h) 30' (9 m) C-C (OVER 45MPH (70 km/h))
RAILROAD CROSSING	24 (600) TRANSVERSE LINES "RR" 15' 6" (4.8 m) LETTERS: 16 (400) LINE FOR "X"	SOLID	WHITE	SEE STATE STANDARD 780001 AREA OF: "R"=3.6 SQ. FT. (0.33 m ²) EACH "X"=54.0 SQ. FT. (5.0 m ²)
SHOULDER DIAGONALS	12 (300) @ 45°	SOLID	WHITE - RIGHT YELLOW - LEFT	50' (15 m) C-C (LESS THAN 30MPH (50 km/h)) 75' (25 m) C-C (30 MPH (50 km/h) TO 45MPH (70 km/h)) 150' (45 m) C-C (OVER 45MPH (70 km/h))

FOR FURTHER DETAILS ON PAVEMENT MARKING REFER TO STANDARD SPECIFICATIONS FOR ROAD AND BRIDGE CONSTRUCTION AND STATE STANDARD 780001.

All dimensions are in inches (millimeters) unless otherwise shown.

FILE NAME = W:\diststd\22x34\13.dgn

USER NAME = geglennob	DESIGNED - EVERS	REVISED - T. RAMMACHER 10-27-94
PLOT SCALE = 50,000' / IN.	DRAWN -	REVISED - A. HOUSEH 10-09-96
PLOT DATE = 1/4/2008	CHECKED -	REVISED - A. HOUSEH 10-17-96
	DATE - 03-19-90	REVISED - T. RAMMACHER 01-06-00

STATE OF ILLINOIS
DEPARTMENT OF TRANSPORTATION

DISTRICT ONE
TYPICAL PAVEMENT MARKINGS

SCALE: NONE SHEET NO. 10 OF 11 SHEETS STA. TO STA.

F.A.U. RTE.	SECTION	COUNTY	TOTAL SHEETS	SHEET NO.
0282	09-00053-00-RS	WILL	11	10
TC-13		CONTRACT NO. 63264		
FED. ROAD DIST. NO. 1 ILLINOIS FED. AID PROJECT ARA-9003-(361)				

LOOPS NEXT TO SHOULDERS

PROVIDE A PAVEMENT REPLACEMENT
NOTE WHICH SHOULD EQUAL
3' (900 mm) X WIDTH OF
PAVED SHOULDER.

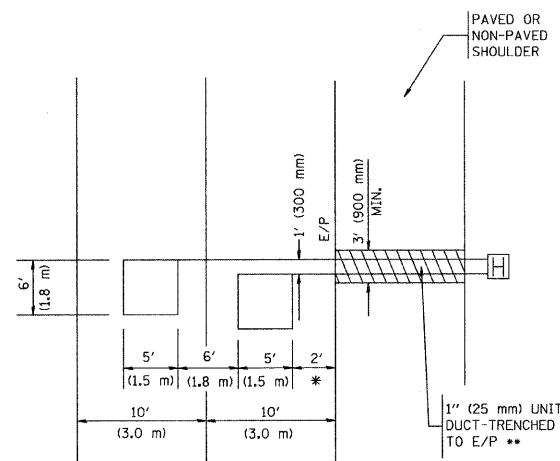

* = (600 mm)

** UNIT DUCT IS TO BE SHOWN ON PLAN SHEETS
BUT SHALL NOT BE INCLUDED IN THE PAY ITEMS.

**LEFT TURN LANES WITH MEDIANS
VOLUME DENSITY ("FAR OUT" DETECTION)
ON SAME APPROACH
(PROTECTED / PERMITTED LEFT TURN PHASING)**

HANDHOLE LOCATION MAY
VARY DEPENDING ON GEOMETRICS
AND DESIGN OF TRAFFIC SIGNALS.
HEAVY-DUTY HANDHOLES TO BE
USED WHEN THE MEDIAN IS
MOUNTABLE. REFER TO STANDARD
814001 TO ENSURE THAT HANDHOLE
FITS IN MEDIAN.

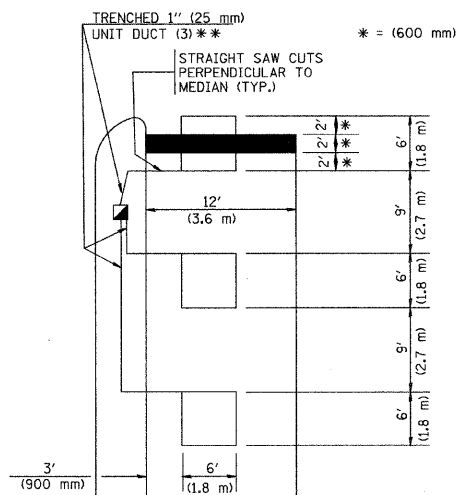

* = (600 mm)

** UNIT DUCT IS TO BE SHOWN ON PLAN SHEETS
BUT SHALL NOT BE INCLUDED IN THE PAY ITEMS.

NOTE: DUAL LEFT TURNS NOT SHOWN REFER TO
PLAN SHEET FOR DETECTOR LOOP REPLACEMENT

**LEFT TURN LANES WITHOUT MEDIANS
VOLUME DENSITY ("FAR OUT" DETECTION)
ON SAME APPROACH
(PROTECTED / PERMITTED LEFT TURN PHASING)**

* = (600 mm)

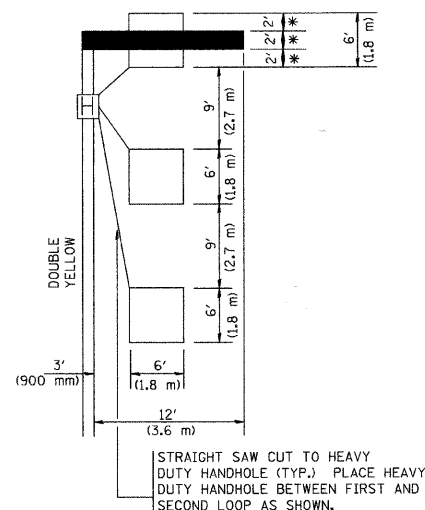

NOTE: DUAL LEFT TURNS NOT SHOWN REFER TO
PLAN SHEET FOR DETECTOR LOOP REPLACEMENT

**ARTERIAL-VOLUME DENSITY ("FAR OUT" DETECTION)
CROSS STREET-VOLUME DENSITY ("FAR OUT" DETECTION)**

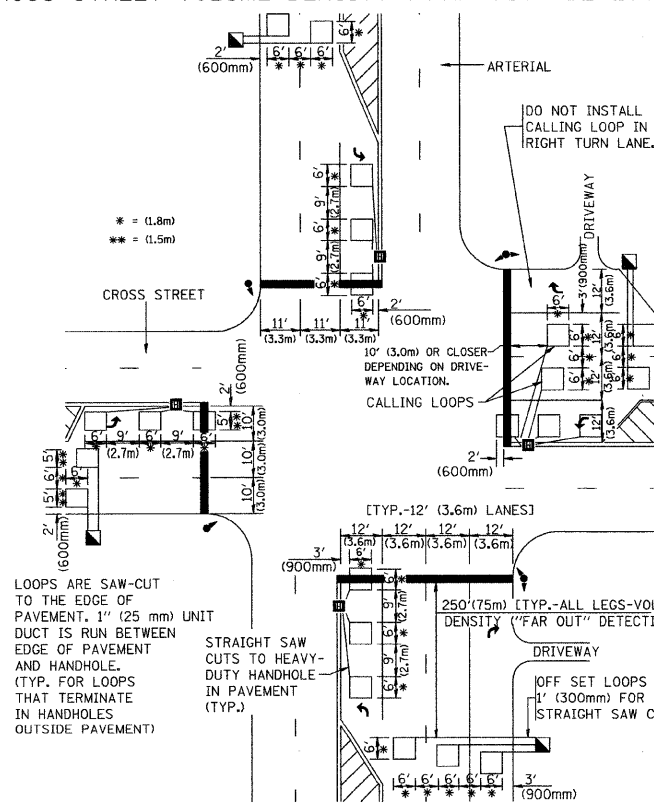

DETAIL 1
N.T.S.

**ARTERIAL-VOLUME DENSITY ("FAR OUT" DETECTION)
CROSS STREET-NON VOLUME DENSITY ("UPTIGHT" PRESENCE DETECTION)**

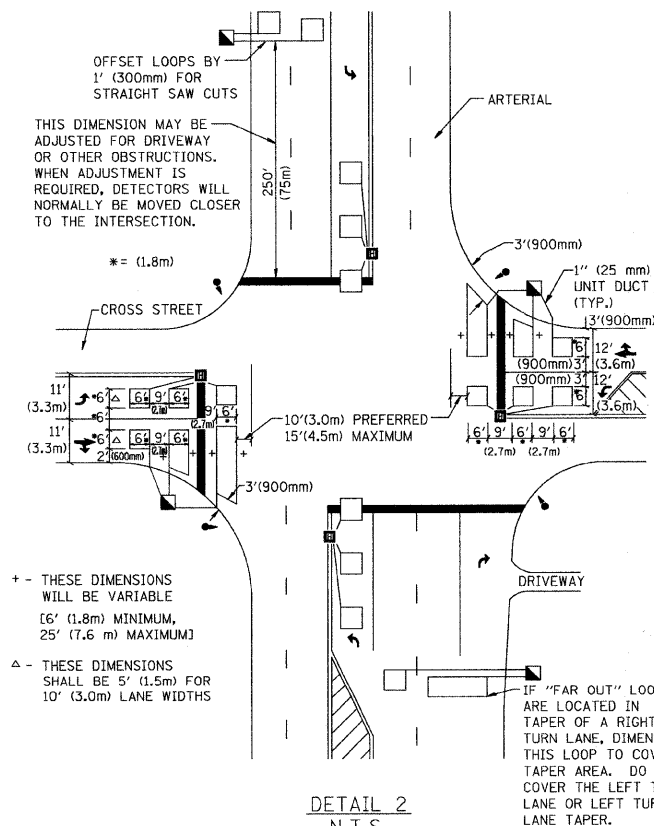

DETAIL 2
N.T.S.

NOTES:

VEHICLES LOOP DETECTORS

- * ALL LEAD IN CABLE SHALL BE TWO CONDUCTOR NO. 14 TWISTED, SHIELDED.
- * EACH DETECTOR LOOP SHALL HAVE ITS OWN SAW CUT FROM THE LOOP TO THE EDGE OF PAVEMENT OR TO A HANDHOLE IN THE PAVEMENT.
- * EACH DETECTOR LOOP SHALL HAVE ITS OWN ONE INCH (25 mm) UNIT DUCT BETWEEN THE EDGE OF PAVEMENT AND THE FIRST HANDHOLE OR JUNCTION BOX. EACH UNIT DUCT RUN SHALL BE SHOWN ON THE PLANS BY THE DESIGNER, BUT SHALL NOT BE PAID FOR SEPARATELY. THIS ITEM IS INCIDENTAL TO THE PAY ITEM FOR DETECTOR LOOPS.
- * ONE DIMENSION OF ALL DETECTOR LOOPS SHALL BE SIX FEET (1.8 m)
- * EACH LANE OF NON-LOCKING, PRESENCE DETECTION AND EACH LANE OF A DOUBLE LEFT TURN LANE REQUIRES A SEPARATE INDUCTIVE LOOP DETECTOR AND LEAD IN CABLE.
- * WHEN NON-LOCKING, PRESENCE DETECTION IS USED, MORE THAN ONE LOOP PER LANE IS REQUIRED BEHIND THE STOP BAR (i.e. 1-1/2, 1-3/4, 2).
- * WHEN SYSTEM LOOPS ARE REQUIRED ON AN APPROACH OF AN INTERSECTION, THE LOOPS USED FOR VOLUME DENSITY AND INTERSECTION TIMING SHALL ALSO BE USED AS SYSTEM DETECTORS. EACH ONE OF THESE TYPE OF LOOPS REQUIRES A SEPARATE TWO CONDUCTOR NO. 14 TWISTED SHIELDED CABLE AND A SEPARATE INDUCTIVE LOOP DETECTOR WHEN NEW CONTROLLERS ARE UTILIZED. THE DESIGNER SHALL LABEL THESE TYPES OF LOOPS AS "INTERSECTION AND SAMPLING (SYSTEM) DETECTORS" ON THE SIGNAL LAYOUT, THE INTERCONNECT PLAN AND THE SYSTEM CABLE PLAN. WHEN AN EXISTING CONTROLLER IS UTILIZED FOR THIS TYPE OF DETECTION, THE PAY ITEM "INDUCTIVE LOOP DETECTOR WITH SYSTEM OUTPUT" SHOULD BE USED.

PLACEMENT OF DETECTORS

THE FOLLOWING FIGURES REPRESENT THE MOST COMMON DETECTOR LOOP LOCATIONS AND SIZES. ADJUSTMENTS WILL BE NECESSARY FOR SPECIFIC GEOMETRIC CONSIDERATIONS.

LOCATIONS AND DIMENSIONS OF DETECTOR LOOPS ARE REQUIRED ON ALL SIGNAL LAYOUT PLAN SHEETS.

"FAR OUT" DETECTION REFERS TO LOCKING, PRESENCE TYPE DETECTION LOCATED IN THRU LANES, RIGHT TURN LANES, AND RIGHT TURN LANE TAPER AREAS (IF APPLICABLE), USUALLY 250' (75 m) IN ADVANCE OF STOP BARS. "UPTIGHT" DETECTION REFERS TO NON-LOCKING PRESENCE TYPE DETECTION LOCATED IN ALL LANES AND 10'-15' (3.0 m-4.5 m) BEHIND THE CROSSING STREET'S EDGE OF PAVEMENT EXTENDED.

NOTE:

ALL DETAILS AND NOTES SHOWN ARE FROM THE I.D.O.T. DISTRICT 1 TRAFFIC SIGNAL DESIGN GUIDELINES DATED JANUARY 1995

THIS DRAWING HAS BEEN PREPARED TO ASSIST THE RESIDENT ENGINEER FOR ALL ROADWAY RESURFACING OR S.M.A.R.T. PROJECTS WHERE THE DIMENSIONS ARE NOT SHOWN ON THE PLANS AND THE FINAL LOCATIONS FOR CROSSWALKS OR STOP BARS ARE NOT DETERMINED.

FILE NAME = W:\distatd\22x34\ts07.dgn	USER NAME = gaglianobt	DESIGNED -	REVISED -	STATE OF ILLINOIS DEPARTMENT OF TRANSPORTATION	DISTRICT ONE - DETECTOR LOOP INSTALLATION DETAILS FOR ROADWAY RESURFACING			F.A.U. RTE.	SECTION	COUNTY	TOTAL SHEETS	SHEET NO.	
		DRAWN -	REVISED -					0282	09-00053-00-RS	WILL	11	11	
		PLOT SCALE = 50.0000" / IN.	CHECKED - R.K.F.					REVISED -	TS-07			CONTRACT NO. 63264	
		PLOT DATE = 1/4/2008	DATE -					REVISED -	SCALE: NONE	SHEET NO. 11 OF 11 SHEETS	STA. TO STA.	FED. ROAD DIST. NO. 1	ILLINOIS