

FAU RTE	SECTION	COUNTY	TOTAL SHEETS	SHEET NO.
1704	09-00015-00-RS	COOK	14	12
F.H.W.A. REG.	ILLINOIS PROJECT	ARA-9003(218)		

CONTRACT NO. 63291

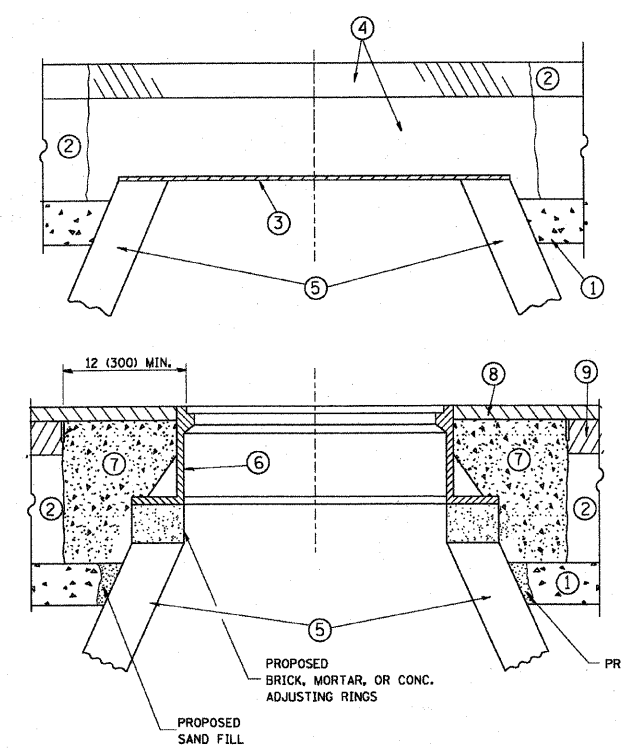

**CONSTRUCTION PROCEDURES**

**STAGE 1 (BEFORE PAVEMENT MILLING)**

- A) REMOVE A MINIMUM OF 12 (300) OF THE PAVEMENT FROM AROUND THE STRUCTURE.
- B) REMOVE THE EXISTING FRAME AND LID FROM THE STRUCTURE.
- C) COVER THE STRUCTURE OPENING WITH A 36 (900) DIAMETER METAL PLATE.
- D) BACKFILL WITH CRUSHED STONE AND A MINIMUM 1 1/2 (40) THICK HMA SURFACE MIX APPROVED BY THE ENGINEER.

**STAGE 2 (AFTER PAVEMENT MILLING)**

- A) REMOVE THE HMA SURFACE MIX AND CRUSHED STONE.
- B) INSTALL THE FRAME AND LID; ADJUST THE FRAME TO ITS FINAL SURFACE ELEVATION.
- C) THE SURROUNDING SPACE SHALL BE FILLED WITH CLASS S1 CONCRETE, OR HMA SURFACE COURSE OR HMA BINDER COURSE TO THE ELEVATION OF THE SURFACE OF THE EXISTING BASE COURSE OR THE BINDER COURSE.

THE PROCEDURE EXPLAINED ABOVE SHALL CONFORM TO THE APPLICABLE PORTIONS OF SECTIONS 353, 406, 602, AND 603 OF THE STANDARD SPECIFICATIONS.

**LEGEND**

- ① SUB-BASE GRANULAR MATERIAL
- ② EXISTING PAVEMENT
- ③ 36 (900) DIAMETER METAL PLATE
- ④ PROPOSED CRUSHED STONE AND HMA SURFACE MIX
- ⑤ EXISTING STRUCTURE
- ⑥ FRAME AND LID (SEE NOTES)
- ⑦ CLASS S1 CONCRETE, HMA SURFACE COURSE OR HMA BINDER COURSE
- ⑧ PROPOSED HMA SURFACE COURSE
- ⑨ PROPOSED HMA BINDER COURSE

**NOTES:**

EXISTING BROKEN FRAMES AND LIDS SHALL BE REMOVED AND DISPOSED OF BY THE CONTRACTOR AND SHALL BE REPLACED AS DIRECTED BY THE ENGINEER. REPLACEMENT FRAMES AND LIDS WILL BE PAID FOR IN ACCORDANCE WITH ARTICLE 109.04 OF THE STANDARD SPECIFICATIONS UNLESS A SEPARATE PAY ITEM HAS BEEN PROVIDED.

IF THE EXISTING LIDS ARE OPEN, THE FRAME WILL BE ADJUSTED TO THE ELEVATION OF THE MILLED PAVEMENT SURFACE PRIOR TO THE MILLING OPERATION. THE FRAME WILL NOT BE REMOVED AND COVERED BY THE METAL PLATE.

CITY OF CHICAGO CASTINGS ARE THE PROPERTY OF THE CITY AND THE CONTRACTOR SHALL NOTIFY THE CITY FOR REMOVAL AND DISPOSITION OF THE CASTINGS.

THE METAL PLATE USED TO COVER THE STRUCTURE SHALL REMAIN THE PROPERTY OF THE CONTRACTOR.

WHEN STRUCTURES ARE TO BE ADJUSTED OR RECONSTRUCTED, THE LOWERING AND RAISING OF THE FRAMES AND LIDS WILL NOT BE PAID FOR SEPARATELY BUT WILL BE INCLUDED IN THE COST OF THE CORRESPONDING PAY ITEM.

**LOCATION OF STRUCTURES:**

THE CONTRACTOR WILL BE REQUIRED TO KEEP A RECORD OF THE LOCATIONS OF THE BURIED STRUCTURES ACCORDING TO THE STATION AND DISTANCE LEFT OR RIGHT OF THE CENTERLINE OF PAVEMENT. UPON COMPLETION OF THE WORK, THE CONTRACTOR WILL DELIVER THE RECORD TO THE ENGINEER.

**BASIS OF PAYMENT:** THIS WORK WILL BE PAID FOR AT THE CONTRACT UNIT PRICE PER EACH FOR

NEW FRAMES AND LIDS, WHEN SPECIFIED, WILL BE PAID FOR SEPARATELY.

**DETAILS FOR FRAMES AND LIDS ADJUSTMENT WITH MILLING**

ALL DIMENSIONS ARE IN INCHES (MILLIMETERS) UNLESS OTHERWISE SHOWN

REVISIONS	
NAME	DATE
R. SHAH	10/25/94
R. SHAH	01/30/98
R. SHAH	03/10/99
A. ABBAS	03/21/97
R. WIEDEMAN	05/14/04
R. BORO	01/01/07

ILLINOIS DEPARTMENT OF TRANSPORTATION  
**DETAILS FOR FRAMES AND LIDS ADJUSTMENT WITH MILLING**

SCALE: VERT. NONE  
HORIZ. NONE

DRAWN BY  
CHECKED BY

BD600-03 (BD-8)

PLOT DATE: 3/16/2007  
FILE NAME: K:\projects\110908.dgn  
PLOT SCALE: DB:BRB / IN.  
USER NAME: baward

**Frank Novotny & Associates, Inc.**  
825 Midway Drive ♦ Willowbrook, IL ♦ 60527 ♦ Telephone: (630) 887-8640 ♦ Fax: (630) 887-0132  
Civil Engineers / Municipal Consultants  
Illinois Professional Design Firm No. 184-000928

PROJECT: VILLAGE OF HODGKINS, ILLINOIS  
63RD STREET PAVING  
LaGRANGE ROAD TO EAST AVENUE  
MFT SECTION NO. 09-00015-00-RS

REVISIONS			
NO.	BY	DATE	DESCRIPTION

**DETAILS FOR FRAMES AND LIDS ADJUSTMENTS WITH MILLING**

PROJECT NO. 06212	SCALE NONE	SHEET 12
DRAWN/DESIGNED JFP/JLC	DATE APR., 2008	OF 14
CHECKED/APPROVED JLC	FIELD BOOK NO. NONE	SHEETS