

STATE OF ILLINOIS
DEPARTMENT OF TRANSPORTATION

Notes:
Existing horizontal and vertical reinforcement extending into new construction shall be cleaned, straightened, and incorporated into the new construction. Cost included with Concrete Removal.
Existing reinforcement not extending into new construction shall be cut off and covered with a 2" layer of cement grout.
Cost shall be included with the cost of Concrete Removal.
Cost of 1" PJF is included with Concrete Structures.
Cost of 2" cement grout is included with Concrete Removal.

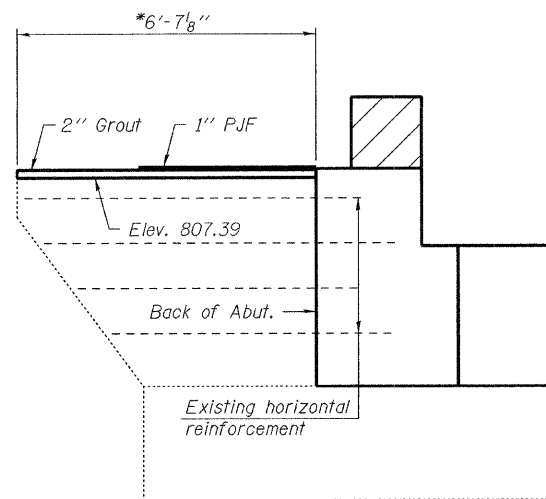

WEST WINGWALL
ELEVATION

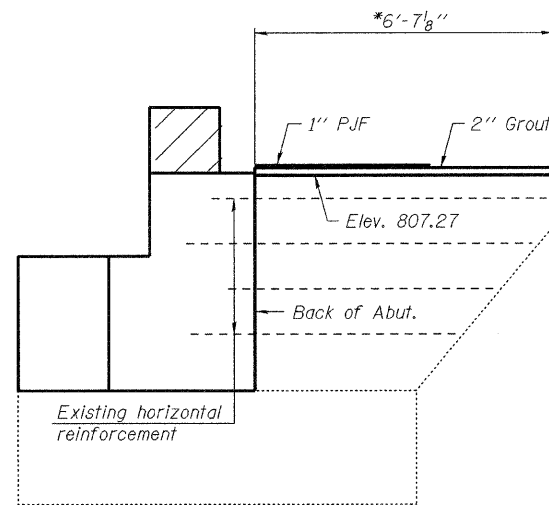

EAST WINGWALL
ELEVATION

* Measured along outside face of wingwall.

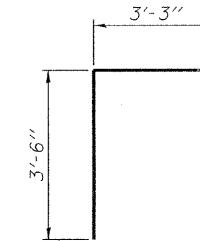

BAR s(E)

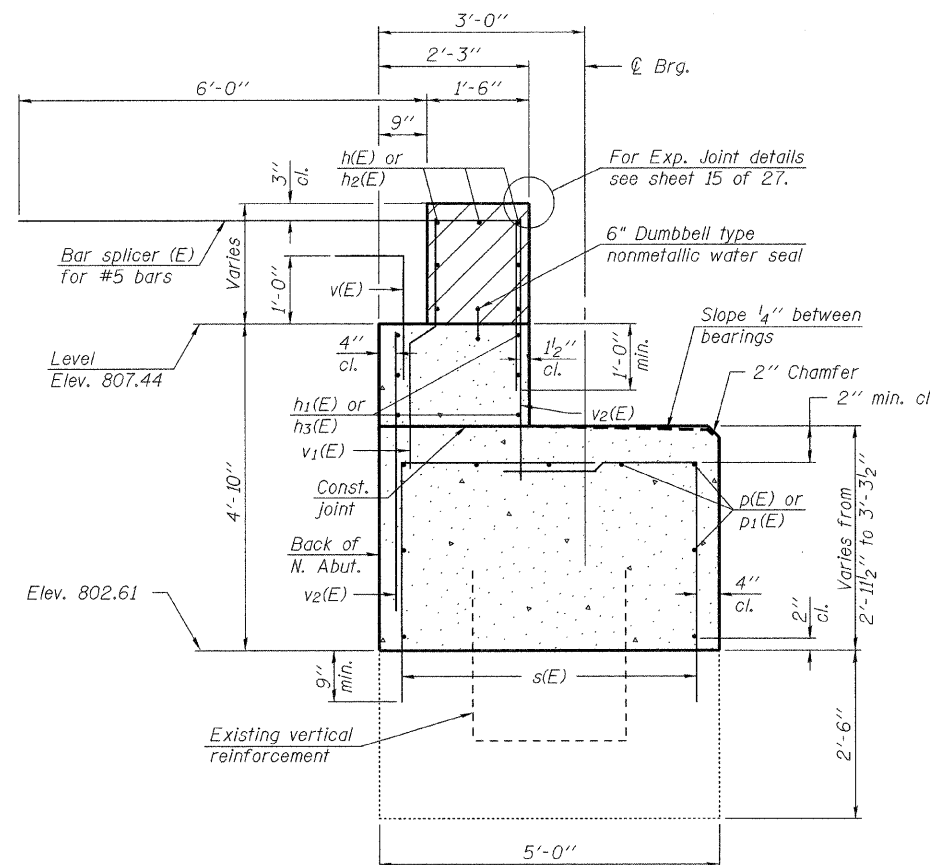

SECTION THRU
ABUTMENT

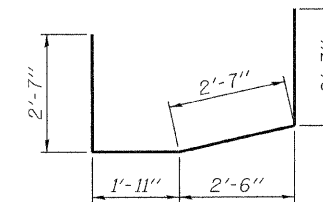

BAR u(E)

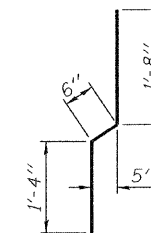

BAR v1(E)



BAR v(E)

NORTH ABUTMENT
BILL OF MATERIAL

Bar	No.	Size	Length	Shape
d2(E)	4	#5	7'-11"	Δ
h(E)	7	#6	24'-4"	—
h1(E)	6	#5	24'-4"	—
h2(E)	7	#6	20'-4"	—
h3(E)	6	#5	20'-4"	—
p(E)	9	#7	24'-4"	—
p1(E)	9	#7	20'-4"	—
s(E)	92	#5	6'-9"	└
u(E)	8	#6	9'-8"	└
v(E)	46	#5	3'-3"	└
v1(E)	46	#4	3'-6"	└
v2(E)	92	#5	3'-11"	—
Structure Excavation			Cu. Yd.	95
Concrete Structures			Cu. Yd.	32.5
Reinforcement Bars, Epoxy Coated			Pound	3,010
Concrete Sealer			Sq. Ft.	198

For details of Bar Splicers, see sheet 26 of 27.
For d2(E) bar bending diagram, see sheet 14 of 27.

NORTH ABUTMENT
STRUCTURE NO. 037-0018 (N.B.)

DESIGNED Michael D. Rolape
CHECKED Nicholas R. Barnett
DRAWN Michael B. Mossman
CHECKED M.D.R./N.R.B./G.R.A.

September 29, 2009
EXAMINED Thomas J. Domagalak
PASSED Ralph E. Anderson
ENGINEER OF BRIDGES AND STRUCTURES

SHEET NO. 23 27 SHEETS	F.A.I. RTE.	SECTION	COUNTY	TOTAL SHEETS	SHEET NO.
	74	37-4HB-1	HENRY	148	116
CONTRACT NO. 64264					
ILLINOIS FED. AID PROJECT					