

STATE OF ILLINOIS
DEPARTMENT OF TRANSPORTATION

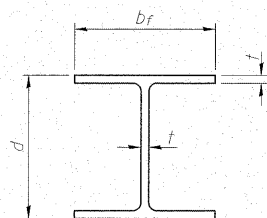

STEEL PILE TABLE

Designation	Depth <i>d</i>	Flange width <i>b_f</i>	Web and Flange thickness <i>t</i>	Encasement diameter <i>A</i>
HP 14x117	14 ¹ / ₄ "	14 ⁷ / ₈ "	1 ³ / ₁₆ "	30"
x102	14"	14 ³ / ₄ "	1 ¹ / ₁₆ "	30"
x89	13 ⁷ / ₈ "	14 ³ / ₄ "	5 ⁵ / ₈ "	30"
x73	13 ⁵ / ₈ "	14 ⁵ / ₈ "	1 ¹ / ₂ "	30"
HP 12x84	12 ¹ / ₄ "	12 ¹ / ₄ "	1 ¹ / ₁₆ "	24"
x74	12 ¹ / ₈ "	12 ¹ / ₄ "	5 ⁵ / ₈ "	24"
x63	12"	12 ¹ / ₈ "	1 ¹ / ₂ "	24"
x53	11 ³ / ₄ "	12"	7 ¹ / ₁₆ "	24"
HP 10x57	10"	10 ¹ / ₄ "	9 ⁹ / ₁₆ "	24"
x42	9 ³ / ₄ "	10 ¹ / ₈ "	7 ¹ / ₁₆ "	24"
HP 8x36	8"	8 ¹ / ₈ "	7 ¹ / ₁₆ "	18"

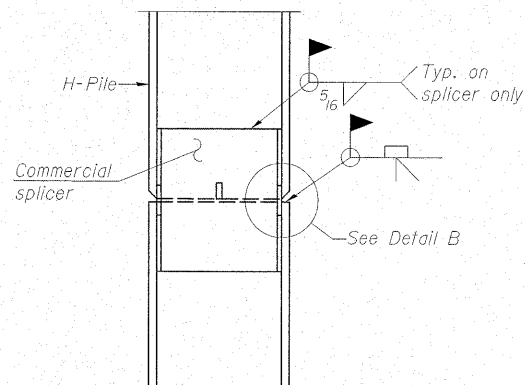

ELEVATION

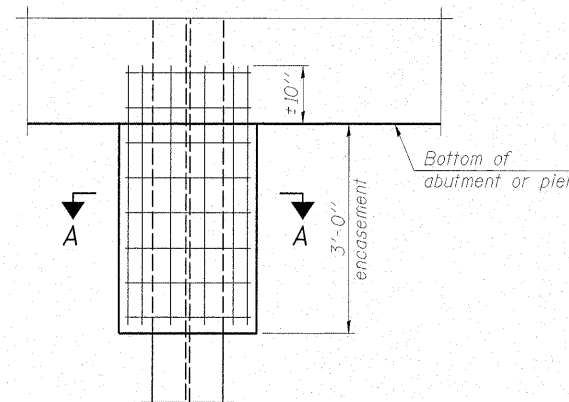

ELEVATION

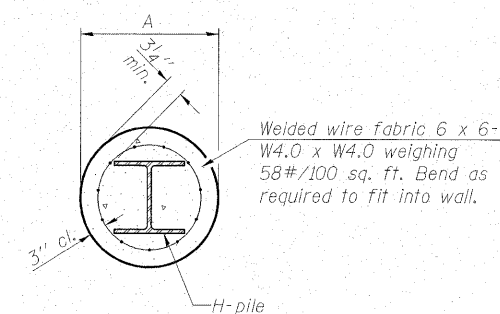

SECTION A-A

Note:
Forms for encasement may be omitted when soil conditions permit.

PILE ENCASEMENT

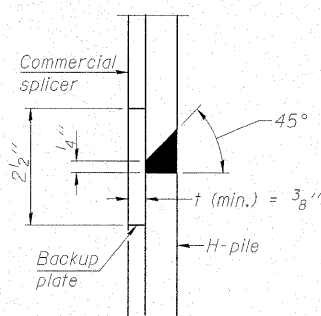

DETAIL "B"

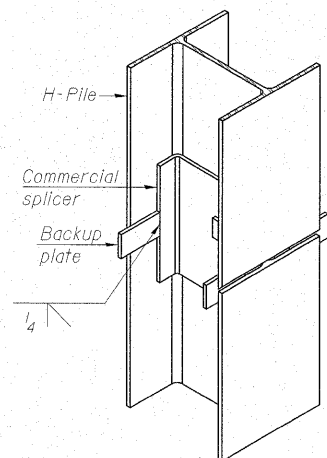

ISOMETRIC VIEW

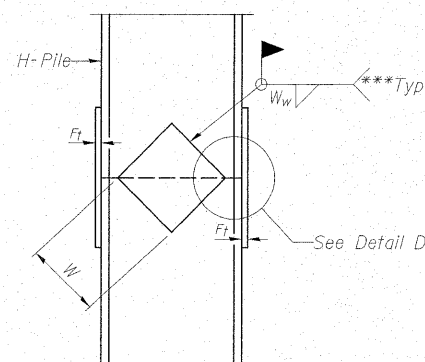

ELEVATION

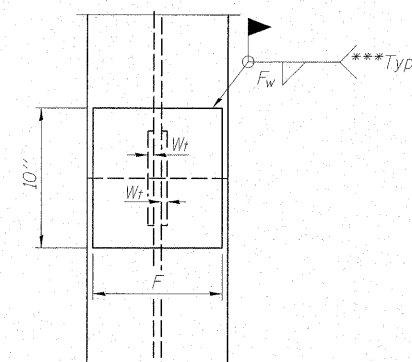

END VIEW

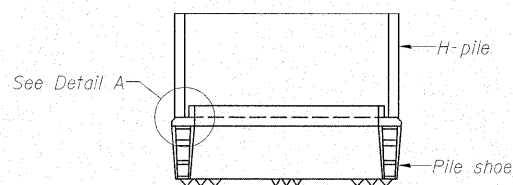

ELEVATION

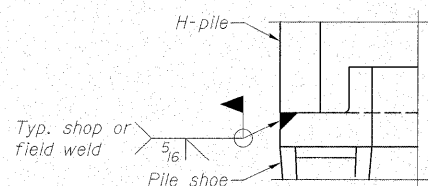

DETAIL A

H-PILE SHOE ATTACHMENT

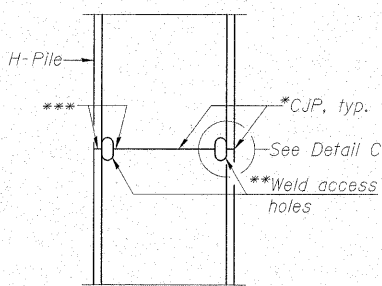

ELEVATION

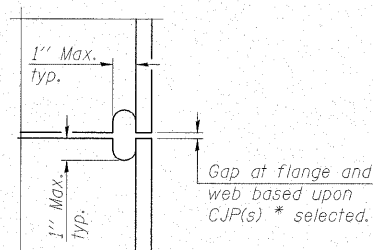

DETAIL C

COMPLETE PENETRATION WELD SPLICE

- * Use joint conforming to Figure 3.4 in AWS D1.1, Structure Welding Code - Steel.
- ** Preparation per Fig. 5.2 in AWS D1.1, Structure Welding Code - Steel.
- *** Interrupt welds 1/4" from end of each pile.

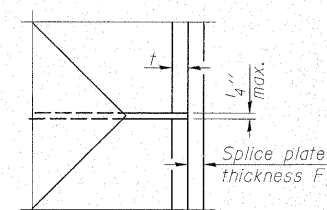

DETAIL D

WELDED PLATE FIELD SPLICE

Designation	<i>F</i>	<i>F_t</i>	<i>F_w</i>	<i>W</i>	<i>W_t</i>	<i>W_w</i>
HP 14x117	12 ¹ / ₂ "	1"	7 ³ / ₈ "	7 ³ / ₄ "	5 ⁵ / ₈ "	1 ¹ / ₂ "
x102	12 ¹ / ₂ "	7 ³ / ₈ "	3 ³ / ₄ "	7 ³ / ₄ "	5 ⁵ / ₈ "	1 ¹ / ₂ "
x89	12 ¹ / ₂ "	3 ³ / ₄ "	1 ¹ / ₁₆ "	7 ³ / ₄ "	5 ⁵ / ₈ "	1 ¹ / ₂ "
x73	12 ¹ / ₂ "	5 ⁵ / ₈ "	9 ⁹ / ₁₆ "	7 ³ / ₄ "	5 ⁵ / ₈ "	1 ¹ / ₂ "
HP 12x84	10"	7 ³ / ₈ "	1 ¹ / ₁₆ "	6 ¹ / ₂ "	5 ⁵ / ₈ "	1 ¹ / ₂ "
x74	10"	7 ³ / ₈ "	1 ¹ / ₁₆ "	6 ¹ / ₂ "	5 ⁵ / ₈ "	1 ¹ / ₂ "
x63	10"	5 ⁵ / ₈ "	1 ¹ / ₂ "	6 ¹ / ₂ "	1 ¹ / ₂ "	3 ³ / ₈ "
x53	10"	5 ⁵ / ₈ "	1 ¹ / ₂ "	6 ¹ / ₂ "	1 ¹ / ₂ "	3 ³ / ₈ "
HP 10x57	8"	3 ³ / ₄ "	9 ⁹ / ₁₆ "	5 ¹ / ₄ "	1 ¹ / ₂ "	3 ³ / ₈ "
x42	8"	5 ⁵ / ₈ "	9 ⁹ / ₁₆ "	5 ¹ / ₄ "	1 ¹ / ₂ "	3 ³ / ₈ "
HP 8x36	7"	5 ⁵ / ₈ "	7 ¹ / ₁₆ "	4 ¹ / ₄ "	1 ¹ / ₂ "	3 ³ / ₈ "

HP PILE DETAILS

IL RTE. 2 WB OVER UNNAMED TRIBUTARY TO THE ROCK RIVER
STATION 115+16.00



DESIGNED - JAE
CHECKED - KEF
DRAWN - SGM
CHECKED - RJA/KEF

F-HP 10-1-08

Note:
The steel H-piles shall be according to AASHTO M270 Grade 50.

SHEET NO. 17 20 SHEETS	F.A.P. RTE.	SECTION	COUNTY	TOTAL SHEETS	SHEET NO.
	561	31-1BR-2	LEE	92	70
	STRUCTURE NO. 052-0079		CONTRACT NO. 64B05		
FED. ROAD DIST. NO. ILLINOIS FED. AID PROJECT					