

STATE OF ILLINOIS  
DEPARTMENT OF TRANSPORTATION

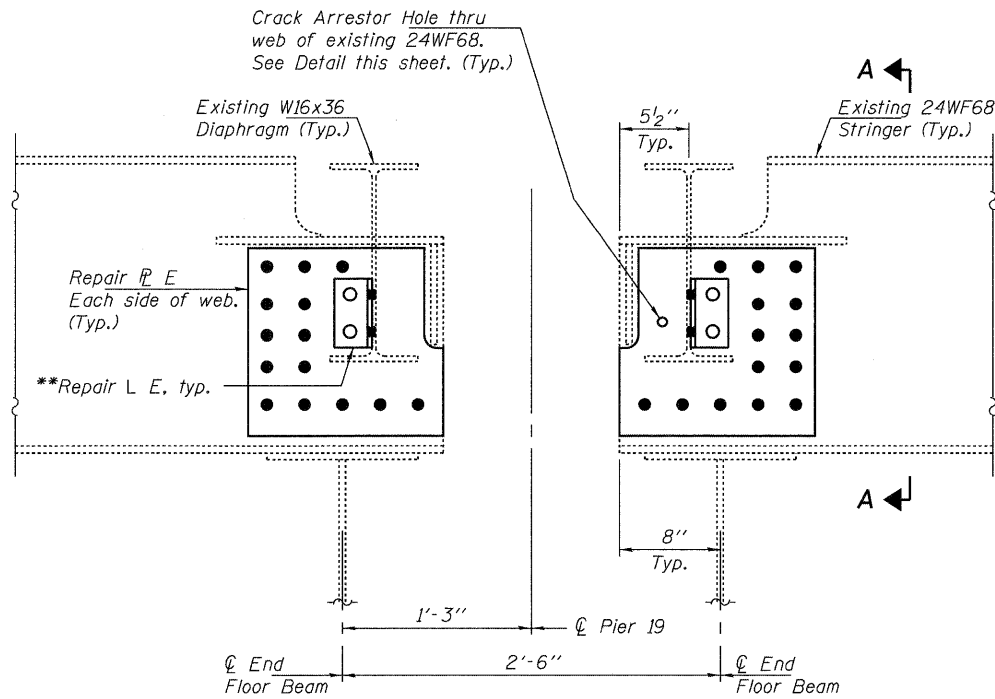

**STRUCTURAL STEEL REPAIR E**

Typical Stringers 3 thru 6 except North side of Stringer 4 (See Repair F)

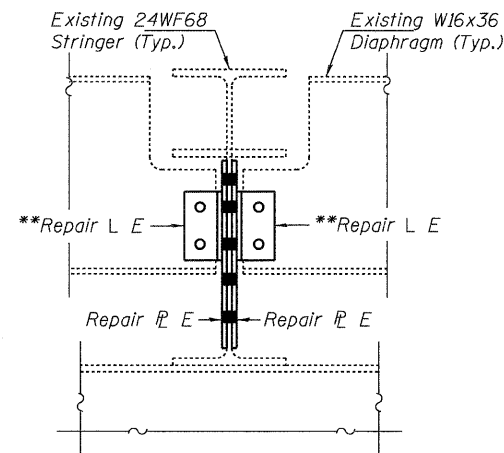

**SECTION A-A**

\*\* Remove existing L 3 x 3 x 3/8

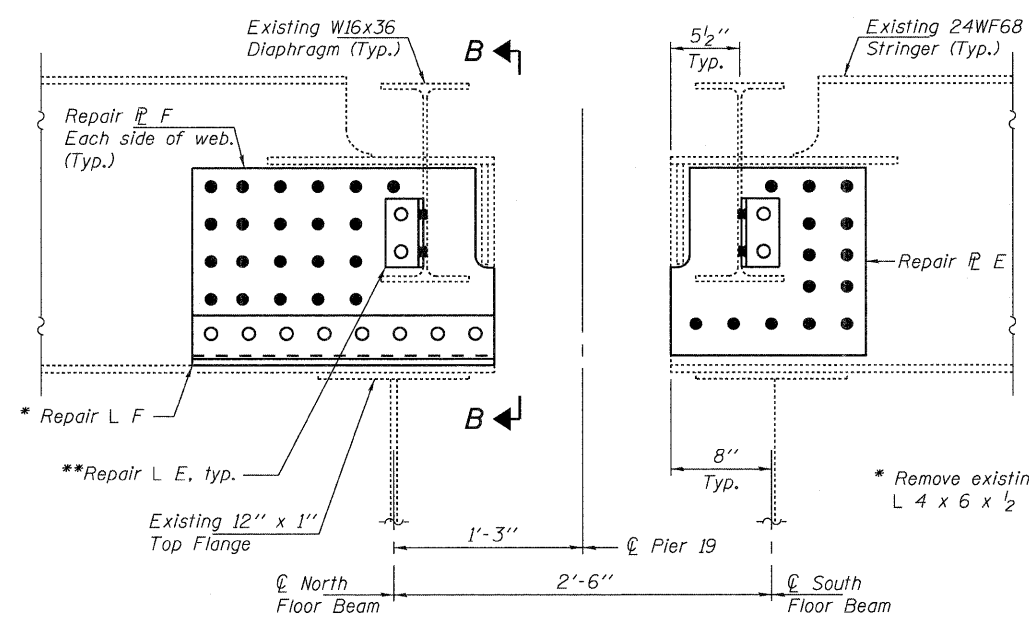

**STRUCTURAL STEEL REPAIR F**

Looking East at Stringer 4

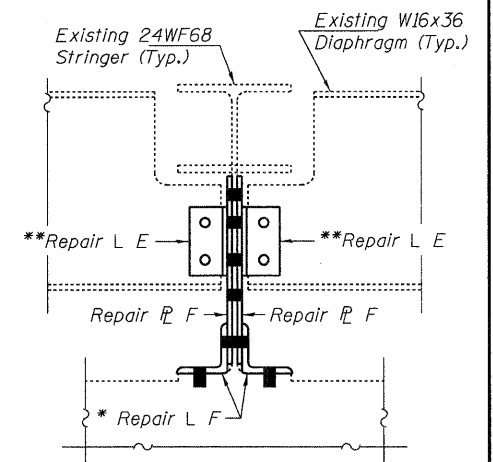

**SECTION B-B**

Note A:  
Field drill holes using existing holes as template. Remainder of holes may be shop or field drilled.

Note:  
Gaps between the existing steel and the new steel angles and/or repair plates shall be sealed with an approval polyurethane sealant. The sealant shall be compatible with the proposed paint system and shall be submitted to the Engineer for approval prior to use. All costs associated with the installation of the sealant shall be included with the cost for Structural Steel Repair.

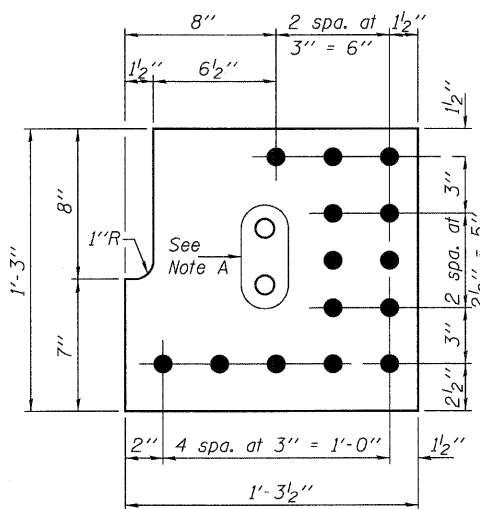

**REPAIR ANGLE E**

L 3 x 3 x 3/8 x 0'-5 1/2" (16 Req'd)  
All Holes to be field drilled.

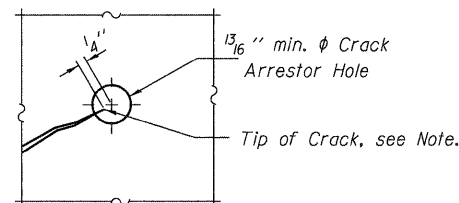

**CRACK ARRESTOR HOLE DETAIL**

Note: Locate crack tip using liquid dye penetrant or magnetic particle testing. Drill 1 3/16" min.  $\bar{\phi}$  Crack Arrestor hole at the crack tip. After crack arrestor hole has been drilled, dye penetrant or magnetic particle testing shall be used to verify that the drilled hole has captured the crack tip. Cost shall be included with Structural Steel Repair.

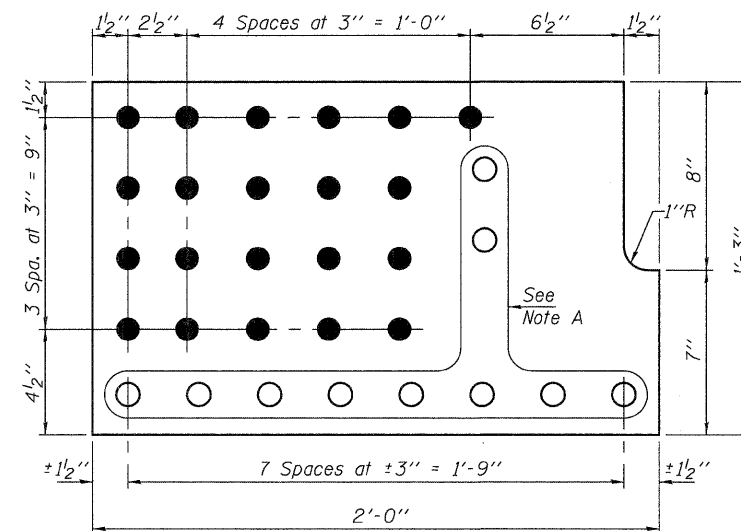

**REPAIR ANGLE F**

L 3/8" x 1'-3" x 2'-0" (2 Required)

**BILL OF MATERIAL**

Item	Unit	Total
Structural Steel Repair	Pound	660

**MISCELLANEOUS STEEL REPAIR DETAILS - 4**

I-80 OVER  
MISSISSIPPI RIVER  
STRUCTURE NO. 081-0011

DESIGNED	IDOT
CHECKED	IDOT
DRAWN	IDOT
CHECKED	IDOT

09/17/09

SHEET NO. 20 33 SHEETS	F.A.I. RTE.	SECTION	COUNTY	TOTAL SHEETS	SHEET NO.
	80	(81-1B)M-4	ROCK ISLAND	75	47
	SN 081-0011			CONTRACT NO. 64F31	
FED. ROAD DIST. NO. 7 ILLINOIS FED. AID PROJECT					