

EXISTING TYPICAL SECTION

STA. 638+50 TO STA. 640+68
STA. 641+68 TO STA. 644+00

*SHOULDER WIDTH VARIES AT GUARDRAIL LOCATIONS

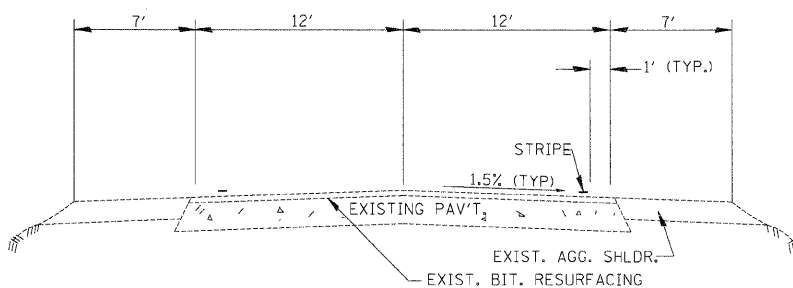

EXISTING TYPICAL SECTION

STA. 678+00 TO STA. 680+30
STA. 681+10 TO STA. 682+85
STA. 683+70 TO STA. 686+00

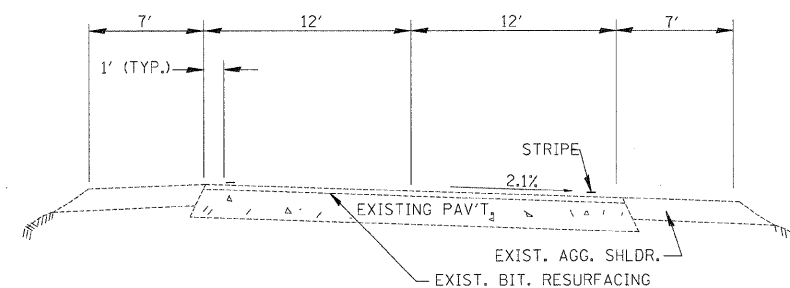

EXISTING TYPICAL SECTION

STA. 751+00 TO STA. 753+95
STA. 754+75 TO STA. 756+50

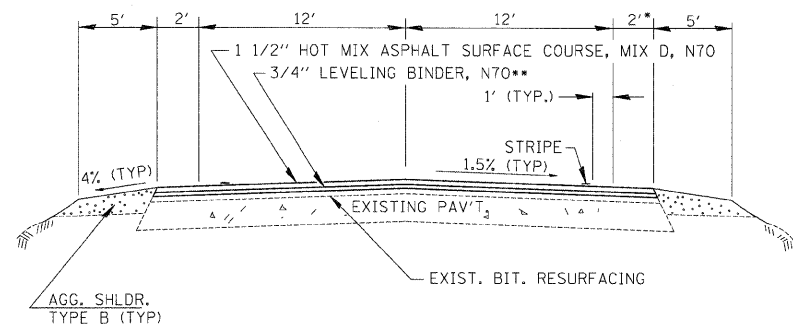

PROPOSED TYPICAL SECTION

STA. 638+50 TO STA. 640+68
STA. 641+68 TO STA. 644+00

*SHOULDER WIDTH VARIES AT GUARDRAIL LOCATIONS
**NOMINAL DEPTH, ACTUAL DEPTH VARIES

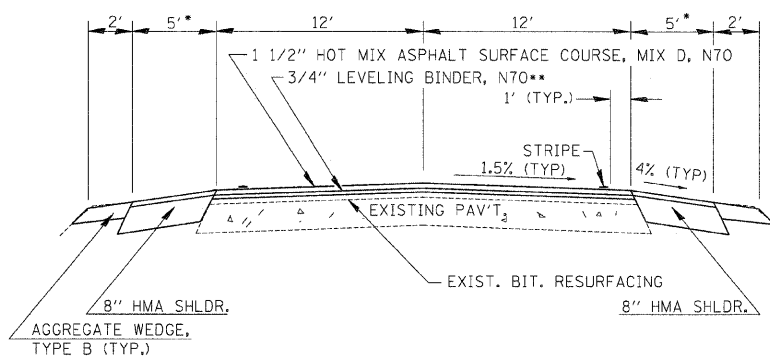

PROPOSED TYPICAL SECTION

STA. 678+00 TO STA. 680+30
STA. 681+10 TO STA. 682+85
STA. 683+70 TO STA. 686+00

*SHOULDER WIDTH VARIES AT GUARDRAIL LOCATIONS

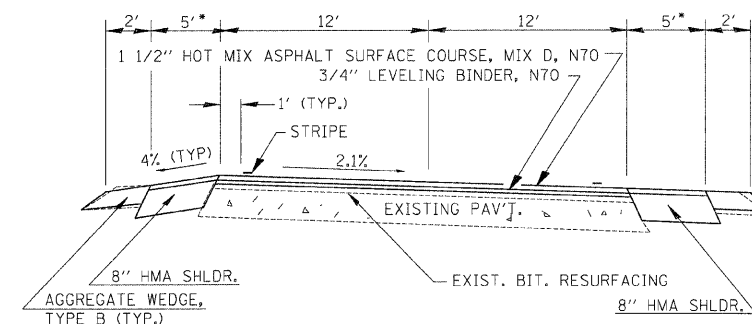

PROPOSED TYPICAL SECTION

STA. 751+00 TO STA. 753+95
STA. 754+75 TO STA. 756+50

*SHOULDER WIDTH VARIES AT GUARDRAIL LOCATIONS

	HMA BASE COURSE	HMA LEVEL BINDER	HMA SURFACE	HMA SHOULDERS
PG GRADE****	PG64-22	PG64-22	PG64-22	PG64-22
MAX % RAP ALLOWABLE	SEE	SPECIAL	PROVISION	
DESIGN AIR VOIDS	4.0% @ N70	4.0% @ N70	4.0% @ N70	4.0% @ N50
MIXTURE COMPOSITION	IL 19.0	IL 9.5	IL 12.5 OR IL 9.5	IL 19.0
FRICITION AGGREGATE			MIXTURE D	
DENSITY TEST METHOD	CORES***	SATISFACTION OF ENGINEER	CORES***	CORES***

*** MATERIAL SHALL BE COMPACTED TO 93.0-97.4 PERCENT OF THE MAXIMUM THEORETICAL DENSITY, EXCEPT THAT WHEN PLACED AS FIRST LIFT ON AN UNIMPROVED SUBGRADE THE MINIMUM PERCENT COMPACTION SHALL BE 92.0 PERCENT. THE MAXIMUM THEORETICAL DENSITY SHALL BE DETERMINED FROM THE MOVING AVERAGE AS SPECIFIED IN THE QC/QA SPECIFICATION.

**** WHEN MORE THAN 20% RAP IS USED, A SOFTER ASPHALT BINDER (PG58-22) MAY BE REQUIRED AS DETERMINED BY THE ENGINEER.

FILE NAME = ...ND966741-SHT-Typical Sections.dgn	USER NAME = SAW	DESIGNED - RAC	REVISED -
		DRAWN - SAW	REVISED -
	PLOT SCALE = 20.0000' / IN.	CHECKED - RAC	REVISED -
	PLOT DATE = 7/14/2009	DATE - 07/17/09	REVISED -

**STATE OF ILLINOIS
DEPARTMENT OF TRANSPORTATION**

**ILLINOIS ROUTE 71
TYPICAL SECTIONS**

SCALE: SHEET NO. OF SHEETS STA. 638+50 TO STA. 756+50

F.A.P. RTE.	SECTION	COUNTY	TOTAL SHEETS	SHEET NO.
311	(3)BR- 1, 2, & (4)BR	LASALLE	66	4
FED. ROAD DIST. NO. [ILLINOIS] FED. AID PROJECT			CONTRACT NO. 66741	