

# PROJECTS WITH RECONSTRUCTION

( 3R IMPROVEMENTS )

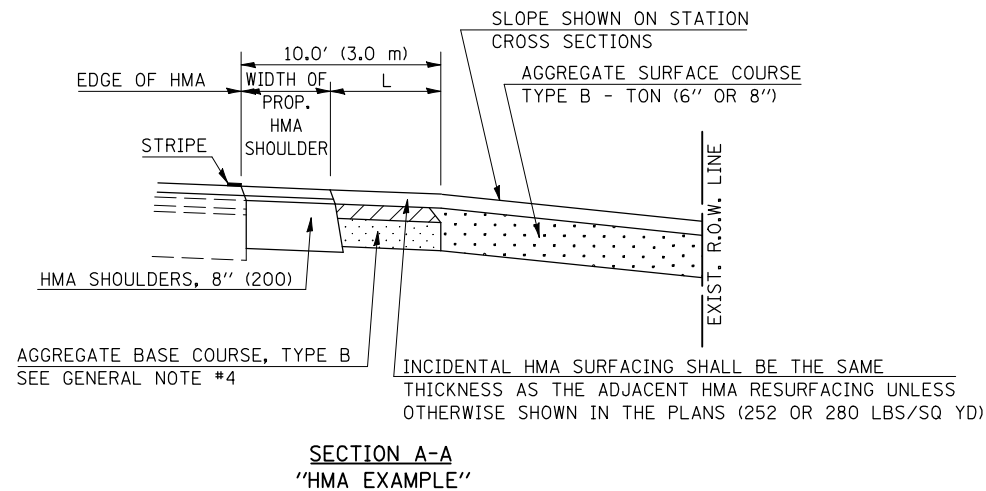
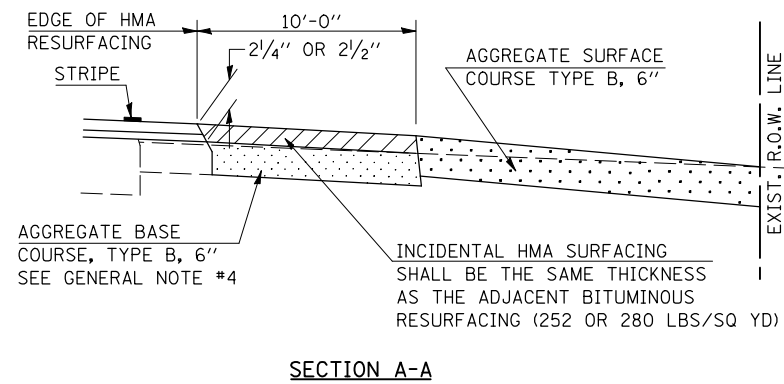
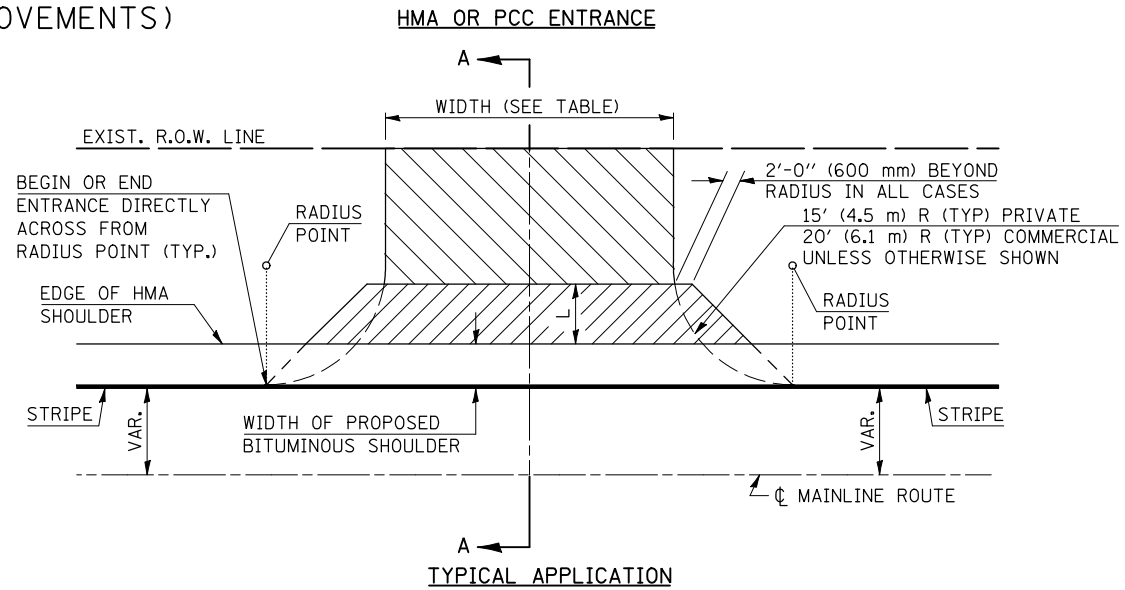
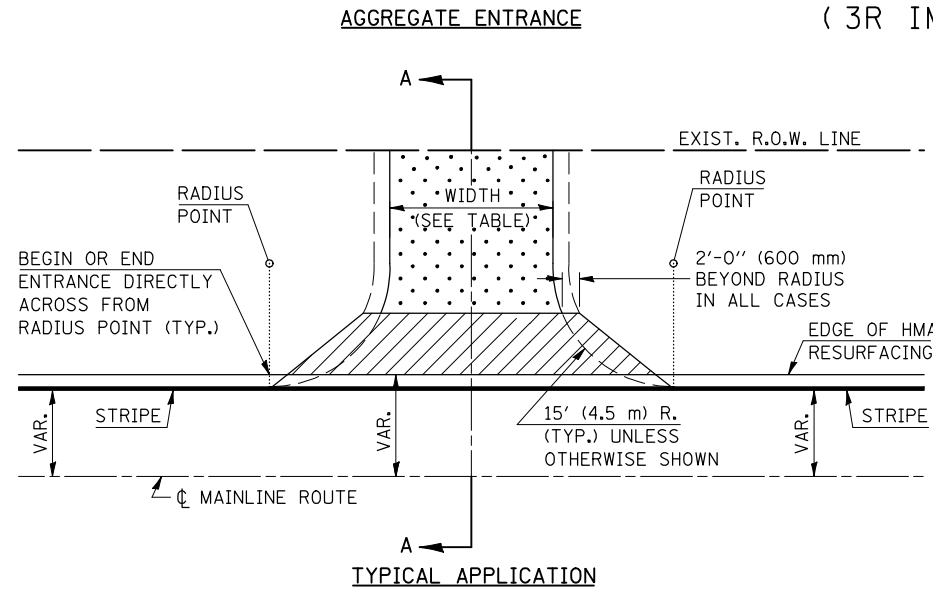

## GENERAL NOTES

1. THE EXISTING SURFACE SHALL BE PREPARED IN ACCORDANCE WITH SECTION 408 OF THE STANDARD SPECIFICATIONS.
2. ANY NECESSARY WORK BEHIND THE HMA SHOULDER OR THE INCIDENTAL HMA SURFACING SHALL BE AS SHOWN IN THE PLANS AND/OR AS DIRECTED BY THE ENGINEER.
3. EARTH EXCAVATION REQUIRED FOR THE CONSTRUCTION OF THE AGGREGATE SURFACE COURSE SHALL BE INCLUDED IN THE COST OF AGGREGATE SURFACE COURSE.
4. AGGREGATE BASE COURSE, TYPE B, 6" (150 mm) MIN. SHALL BE USED WHERE IN THE OPINION OF THE ENGINEER THERE IS NOT SUFFICIENT BASE MATERIAL FOR THE PROPOSED ENTRANCES. THIS MATERIAL SHALL GENERALLY BE USED TO WIDEN ANY EXISTING RETURN OR TO CONSTRUCT NEW ENTRANCES WHERE NONE NOW EXISTS.
5. THE AGGREGATE BASE COURSE SHALL BE CONSTRUCTED 12" (300 mm) WIDER THAN THE SURFACE DIMENSIONS AS SHOWN ABOVE.
6. EXISTING FIELD ENTRANCES OF AGGREGATE OR EARTH WITH NO HMA APRON SHALL NOT RECEIVE A NEW HMA APRON WITHOUT PROPER APPROVAL THROUGH THE BUREAU OF OPERATIONS "POLICY ON PERMITS FOR ACCESS DRIVEWAYS TO STATE HIGHWAYS".
7. TO ASSURE APPROPRIATE ACCESS POLICIES ARE FOLLOWED ALL NEW ACCESS SHALL BE APPLIED FOR THROUGH THE BUREAU OF OPERATIONS PERMIT APPLICATION PROCESS. PLAN PREPARATION MEMORANDUMS 40-09 AND 40-11 ALONG WITH DISTRICT CONSTRUCTION MEMORANDUM 03/14 DISCUSS THIS PROCEDURE.

RURAL ENTRANCE DESIGN STANDARDS (PPM 40-09)															
DESIGN ELEMENT	NEW CONSTRUCTION & 3R with RECONSTRUCTION						3R w/out RECONSTRUCTION, 3P, SMART & CM								
	NONCOMMERCIAL						NONCOMMERCIAL								
	PRIVATE & FIELD			FIELD W/ FARM IMPLEMENTS			COMMERCIAL			PRIVATE & FIELD			COMMERCIAL		
	min.	des.	max.	min.	max.	min.	des.	max.	min.	des.	max.	min.	des.	max.	
SURFACE WIDTH (FT)	12, 16, 24, 24, 30						1 LANE, 1 WAY			resurface existing configuration; existing hma or pcc entrances shall have "butt joints" constructed; existing aggregate or earth entrances shall have the continuation of aggregate shoulders placed behind them					
							14, 16, 24								
RADIUS (FT)	15, 25, 40, 30						2 LANE, 2 WAY								
							24, 30, 35								
SHOULDER WIDTH (FT)	2						1								
SHOULDER SLOPE (%)	2						2								
ENTRANCE GRADE (%)	0						0								
SIDE SLOPE (FT)	1:10						1:10								
<b>SURFACE TYPE</b>															
INCIDENTAL HMA SURFACING (INCH)	2						3 or 4			taper from hma resurfacing thickness (2 1/2", 2 1/4" or 1 1/2") to 1 1/2" for "butt joints" and to minimize aggregate shoulder					
AGGREGATE SURFACE COURSE, TYPE B (INCH)	6						8			if applicable use items: Preparation of Base & Aggregate Base Repair; see PPM 30-02					
PCC DRIVEWAY PAVEMENT (INCH)	6									6 or 8					

Note: All dimensions are in INCHES (millimeters) unless otherwise shown.

FILE NAME =	USER NAME = stultsjw	DESIGNED -	REVISED - 12/08/06 TJB
et:\pw\work\PWID01\STULTSJW\d0158664\0570429-shr-entrance-details.dgn		DRAWN -	REVISED - 09/21/07 KAG
	PLOT SCALE = 40.0000' / IN.	CHECKED -	REVISED - 05/02/08 KJT
	PLOT DATE = 8/17/2009	DATE -	REVISED -

**STATE OF ILLINOIS  
DEPARTMENT OF TRANSPORTATION**

<b>PRIVATE AND COMMERCIAL ENTRANCES (NONCOMMERCIAL AND COMMERCIAL RURAL)</b>			
SCALE: NA	SHEET NO. 2 OF 2 SHEETS	STA.	TO STA.

DISTRICT 5 DETAIL NO. 4080050C				
F.A.P. RTE.	SECTION	COUNTY	TOTAL SHEETS	SHEET NO.
71	(121BR)BR	DEWITT	75	22
			CONTRACT NO. 70429	
FED. ROAD DIST. NO.		ILLINOIS FED. AID PROJECT		