

F.A.I. RTE.	SECTION	COUNTY	TOTAL SHEETS	SHEET NO.
55	*	MCLEAN	310	20
FED. ROAD DIST. NO. ILLINOIS		FED. AID PROJECT		
(57-4)R, HBY, HBR, (57-4)B)DM		CONTRACT #70757		

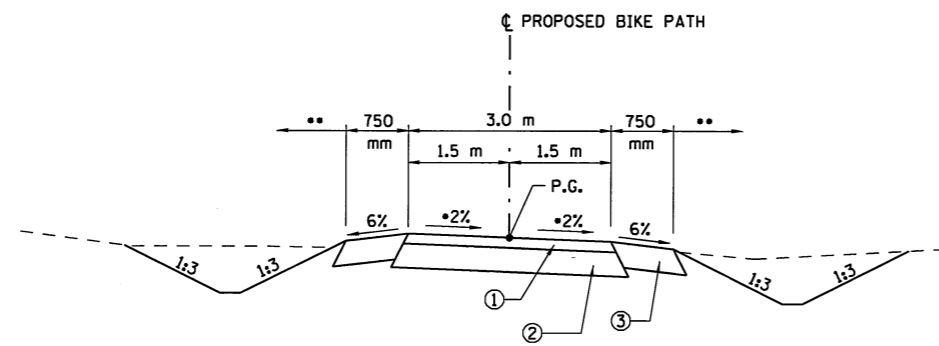

TYPICAL BIKE PATH SECTION
 STA. 0+010.000 TO STA. 0+333.606
 STA. 0+405.652 TO STA. 0+734.277

- TRANSITION TO REVERSE CROSS-SLOPE FROM STA. 0+300.056 TO STA. 0+310.056 AND FROM STA. 0+422.623 TO STA. 0+432.623
- SEE BIKE PATH CROSS SECTIONS FOR VARIATIONS IN DITCH SECTION

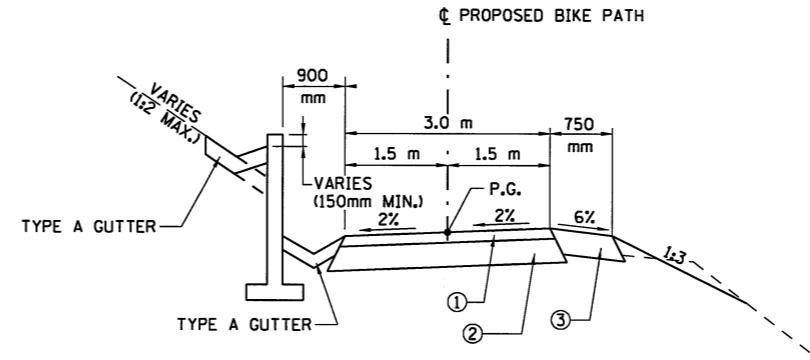

TYPICAL BIKE PATH SECTION
 STA. 0+333.606 TO STA. 0+348.223
 STA. 0+389.981 TO STA. 0+405.652

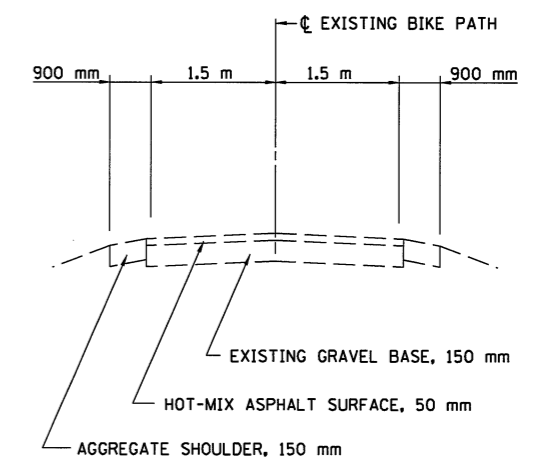

BIKE PATH EXISTING TYPICAL SECTION

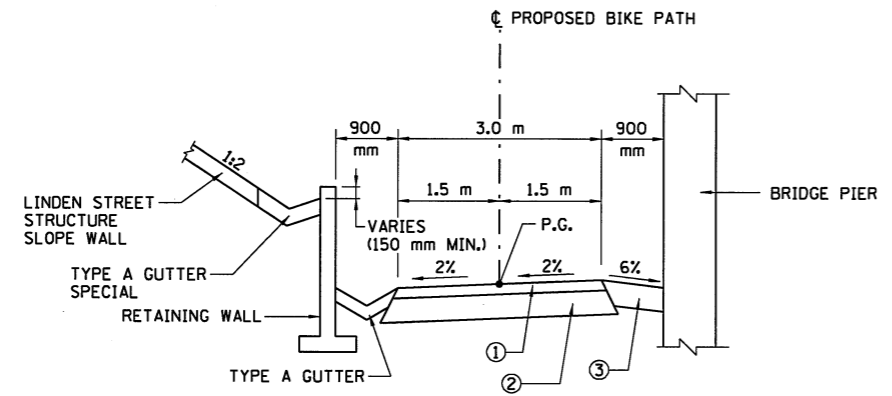

BIKE PATH SECTION UNDER LINDEN ST. STRUCTURE
 STA. 0+348.223 TO STA. 0+354.851
 STA. 0+379.105 TO STA. 0+389.981

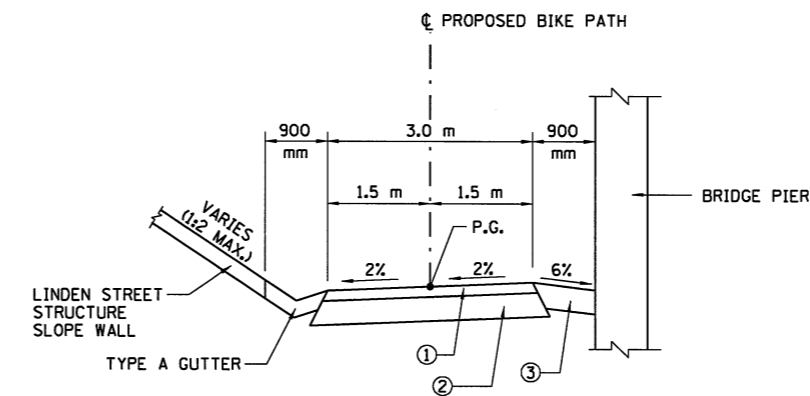

BIKE PATH SECTION UNDER LINDEN ST. STRUCTURE
 STA. 0+354.851 TO STA. 0+379.105

- LEGEND**
- ① 50 mm HOT-MIX ASPHALT SURFACE COURSE, IL 9.5L
 - ② 150 mm AGGREGATE BASE COURSE, TYPE A, M TON
 - ③ 150 mm AGGREGATE SHOULDER, TYPE B, M TON

ILLINOIS DEPARTMENT OF TRANSPORTATION
 F.A.I. 55
 SECTION (57-4)R, HBY, HBR, (57-4)B)DM
 MCLEAN COUNTY

TYPICAL SECTIONS BIKE PATH

REVISED	DATE

DATE: 4/13/2009

JOB NO. 94S2063

4/13/2009	RF/ELR
04/03/02	
04/03/02	
04/03/02	
04/03/02	