

CONTRACT NO. 70757	ROUTE NO. 1-55	SECTION (57-4HB-3)BR	COUNTY McLean	TOTAL SHEETS 310	SHEET NO. 228
FED. ROAD DIST. NO. 7			ILLINOIS PROJECT	Sheet 28 of 31	

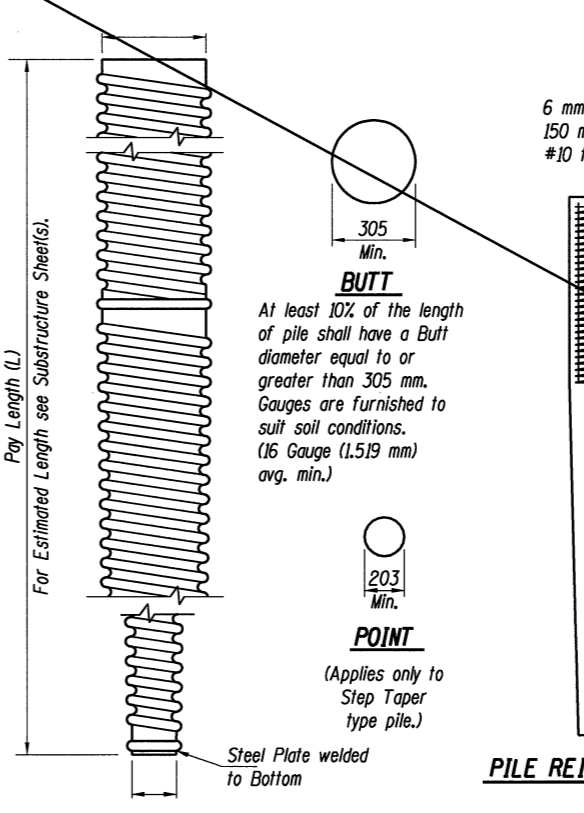
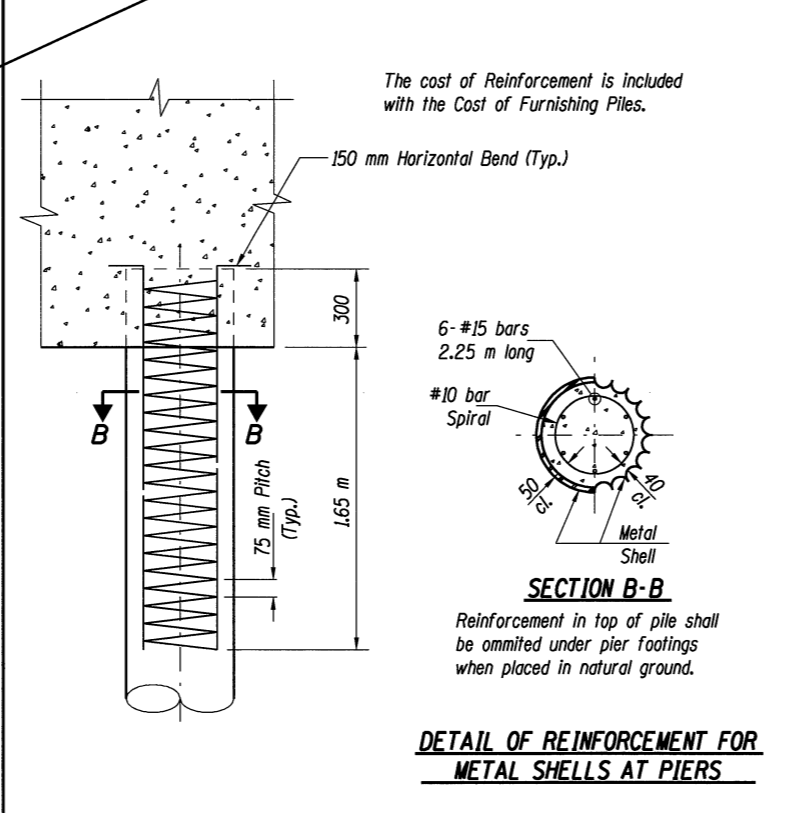
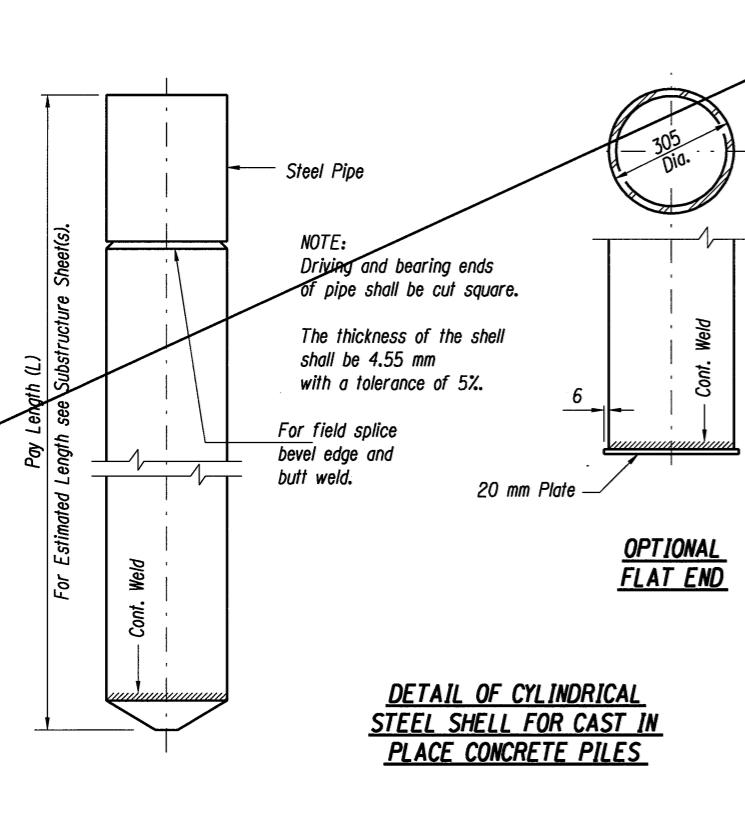
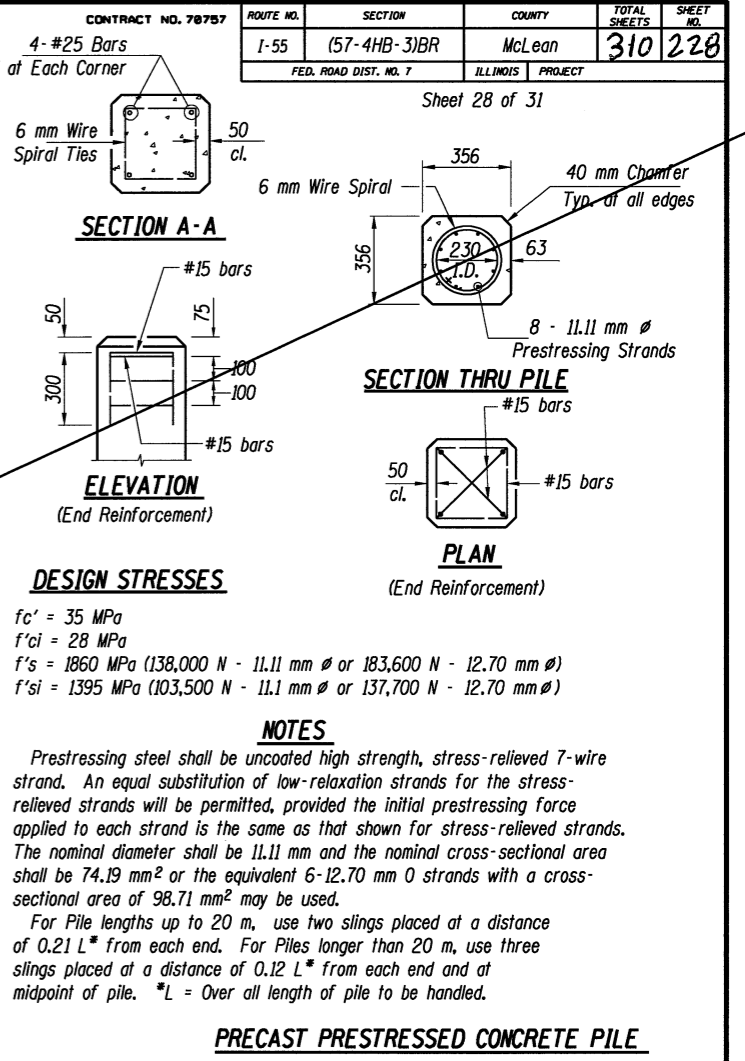
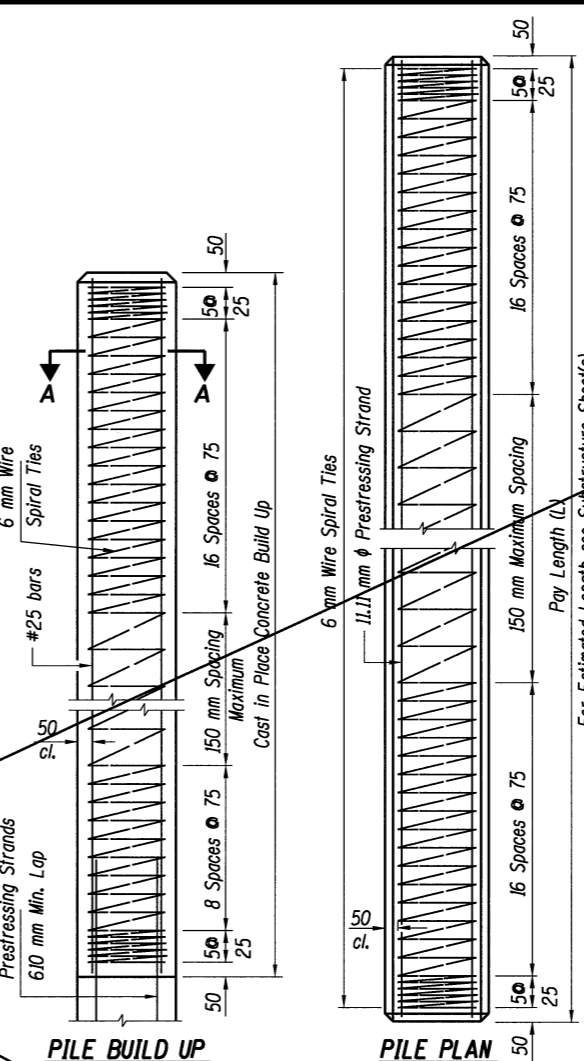
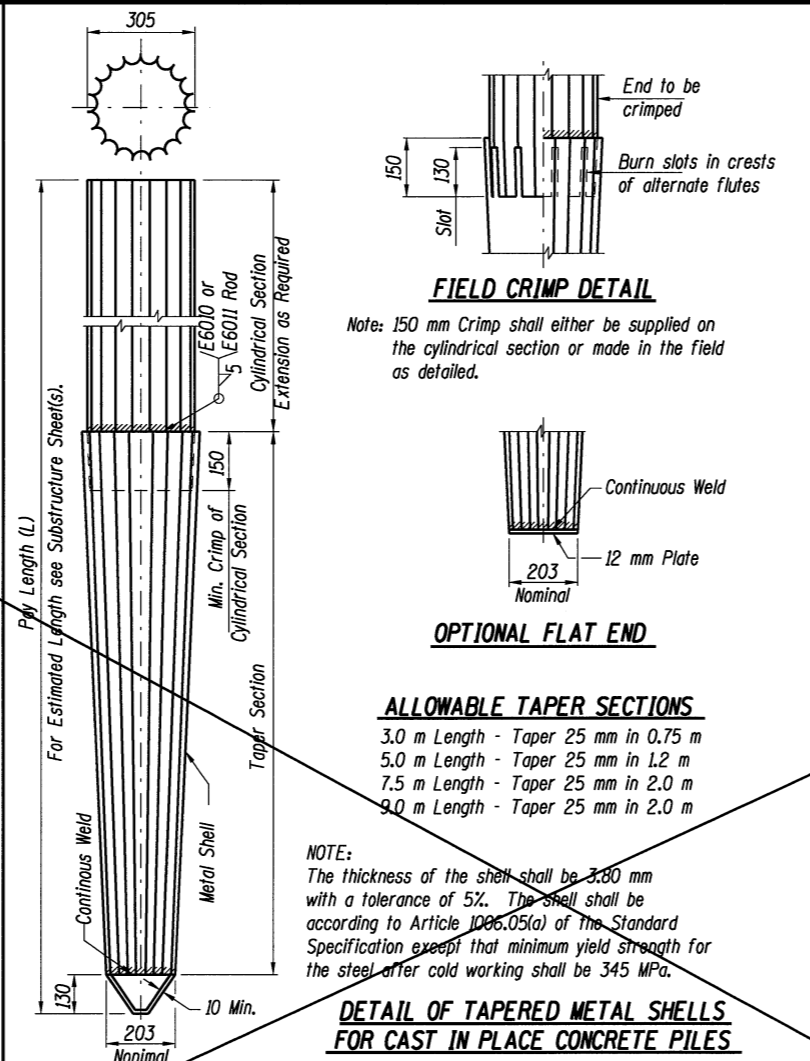
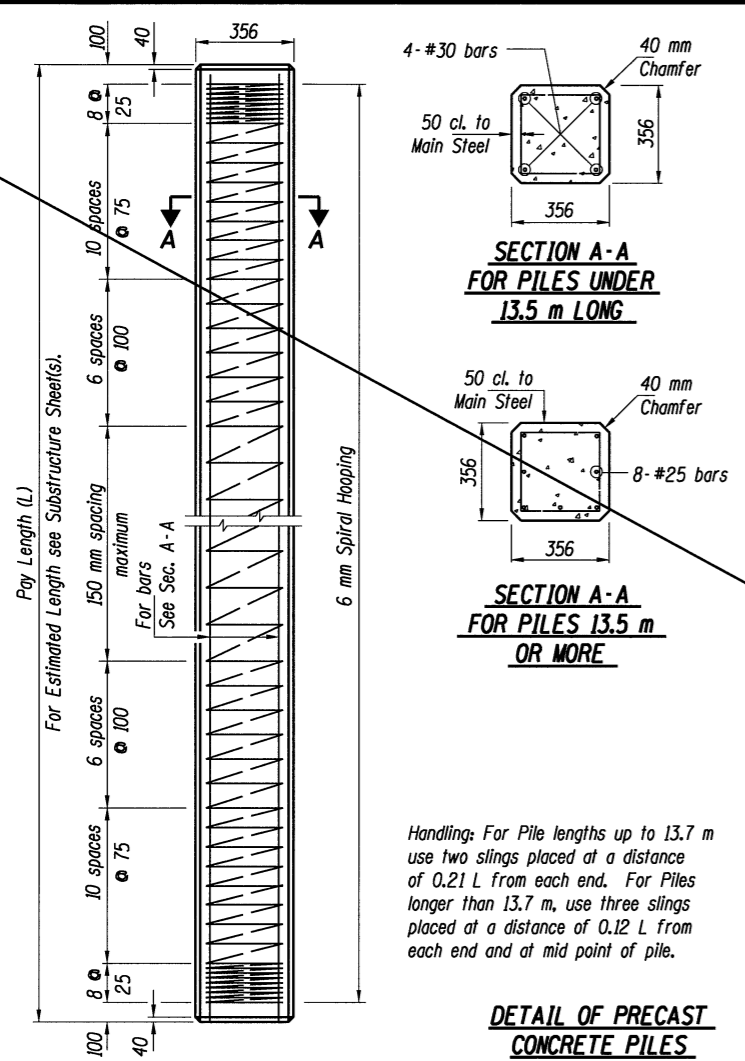

(All dimensions are in millimeters (mm) except as noted.)

CONCRETE PILES AT PIERS
F.A.I. 55 OVER LINDEN STREET
SECTION (57-4HB-3)BR
STRUCTURE NO. 057-0235 (N.B.) & 057-0236 (S.B.)
McLEAN COUNTY
STATION 38+544.044

© Copyright Hanson Professional Services Inc. 2003

94S2063
DATE 03/26/04

HANSON

TIME \$
8/16/2009
DRAWN
REVIEWED

LAYOUT	G.L.C.	11/5/97
DRAWN	D.A.R.	11/5/97
REVIEWED		