

STATE OF ILLINOIS
DEPARTMENT OF TRANSPORTATION

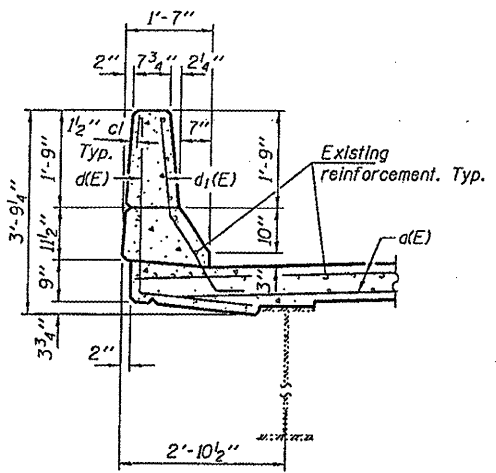

TYPICAL SECTION THRU PARAPET

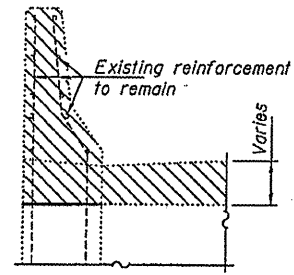

SECTION C-C

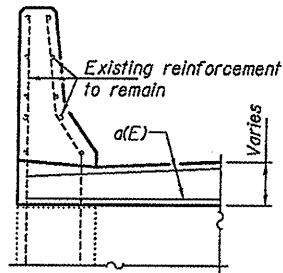

SECTION D-D

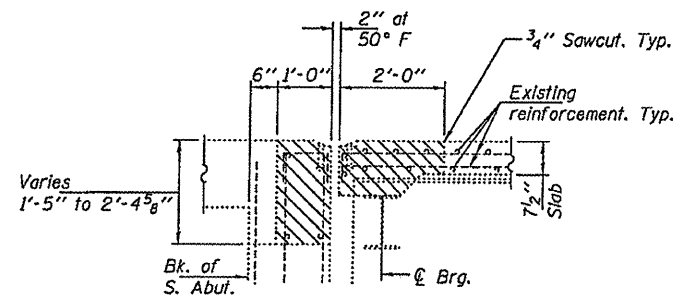

SECTION A-A

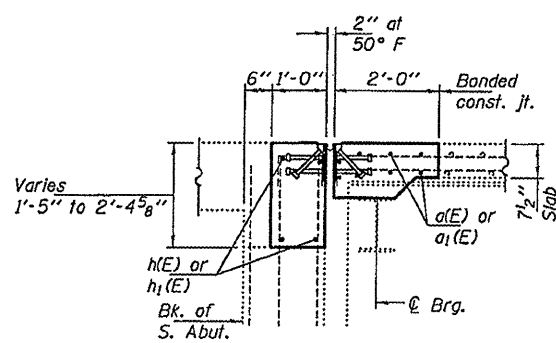

SECTION B-B

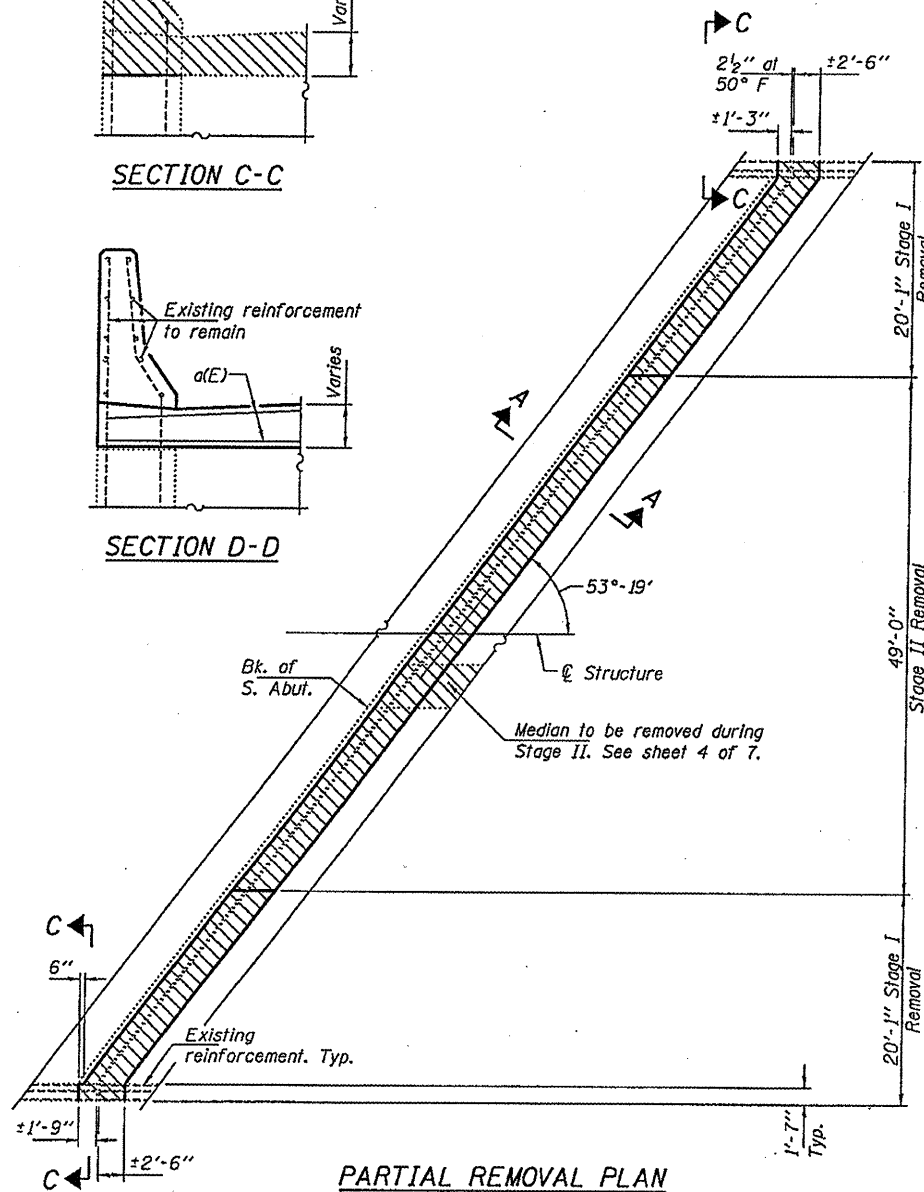

PARTIAL REMOVAL PLAN

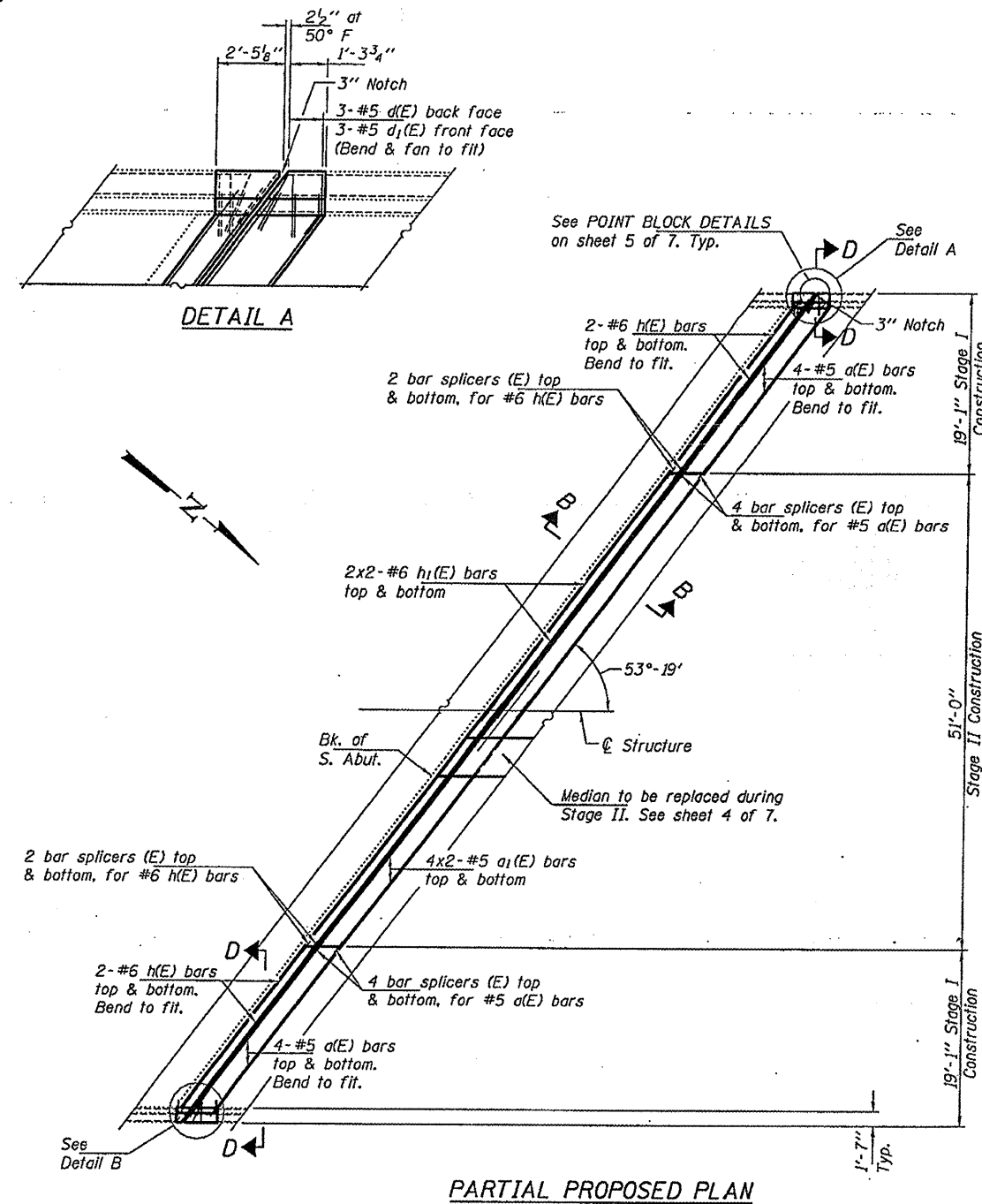

PARTIAL PROPOSED PLAN

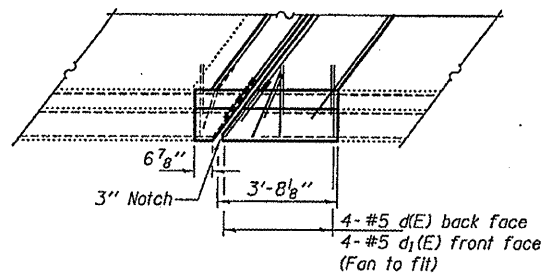

DETAIL B

DETAIL A

MINIMUM BAR LAPS

#5 bar = 2'-2"
#6 bar = 2'-7"

Note:
Hatched areas indicate concrete removal.
See sheet 1 of 7 for staging.
Bars indicated thus 4 x 2-#5 etc. indicates 4 lines of bars with 2 lengths per line.
For bar details & Bill of Material, see sheet 4 of 7.
Dimensions are based on a rolled rail expansion joint.
If the Contractor elects to use the welded rail expansion joint, the opening and deck dimensions shall be modified according to the dimensions detailed on sheet 5 of 7.

SOUTH ABUTMENT DETAILS
US RTE 150 OVER I-74
SN 057-0073

DESIGNED	GGE
CHECKED	AJB
DRAWN	boliva
CHECKED	GGE AJB

SEPTEMBER 16, 2009
EXAMINED *Carl Perry*
ENGINEER OF STRUCTURAL SERVICES
PASSED *Ralph E. Anderson*
ENGINEER OF BRIDGES AND STRUCTURES

SHEET NO. 2 7 SHEETS	F.A.S. RTE.	SECTION	COUNTY	TOTAL SHEETS	SHEET NO.
	2466	(57-18)BJR	Mc LEAN	17	12
FED. ROAD DIST. NO.			ILLINOIS FED. AID PROJECT		
CONTRACT NO. 70807					