

DETAILS OF MAILBOX TURNOUTS

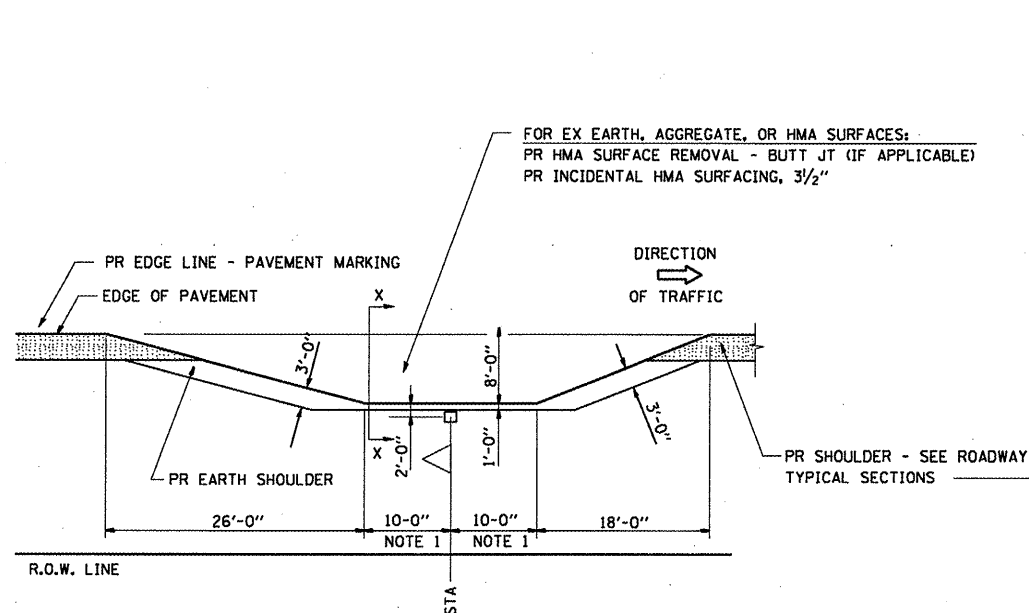

PLAN - MAILBOX TURNOUTS

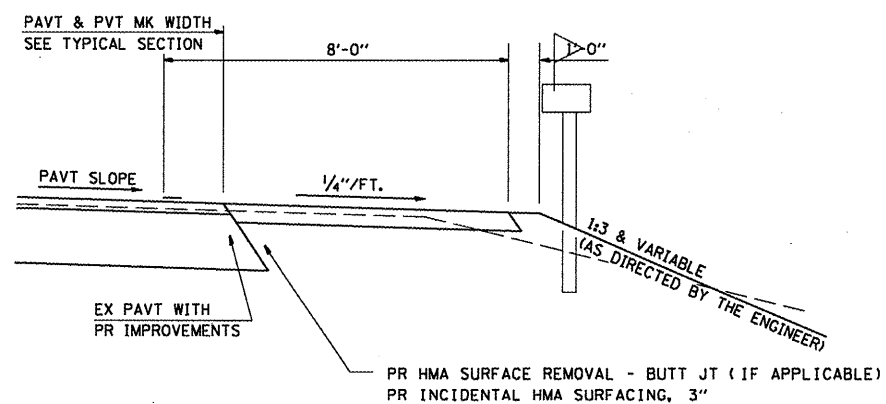

SECTION X-X THRU MAILBOX TURNOUT
 ALSO APPLIES TO MAILBOX TURNOUTS COMBINED WITH
 EX EARTH, AGGREGATE, OR HOT-MIX ASPHALT PE & FE

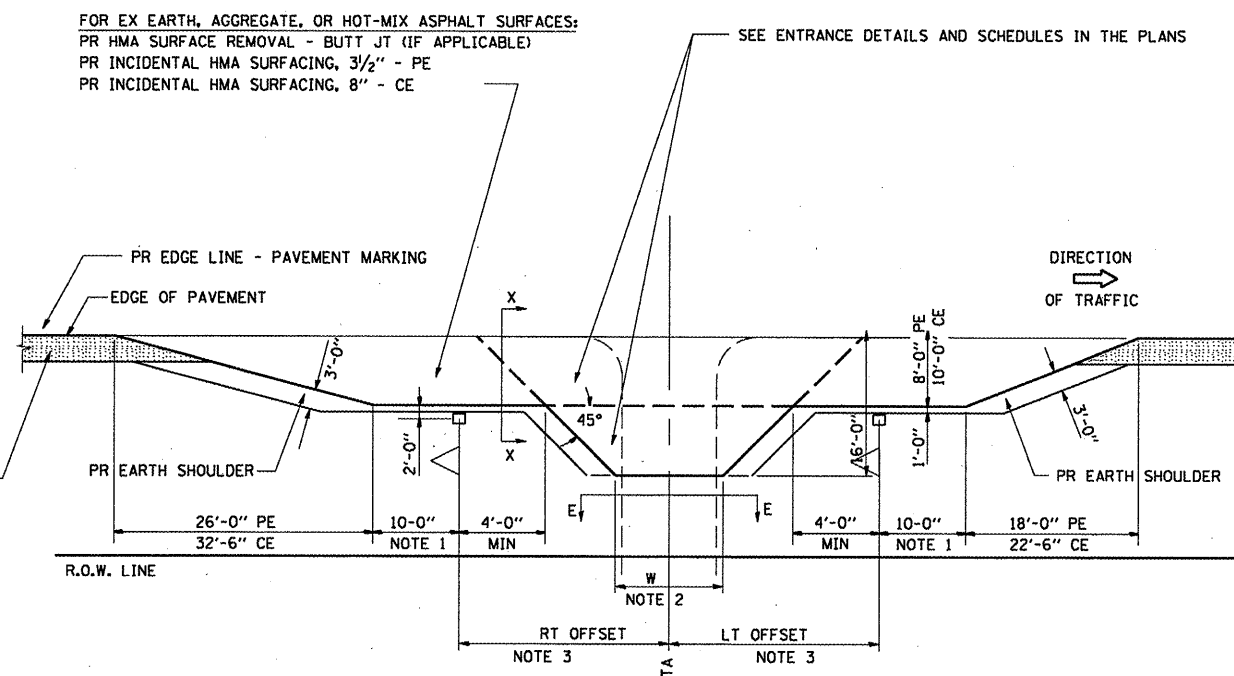

PLAN - COMBINED MAILBOX TURNOUT WITH TRAILING OR LEADING ENTRANCE

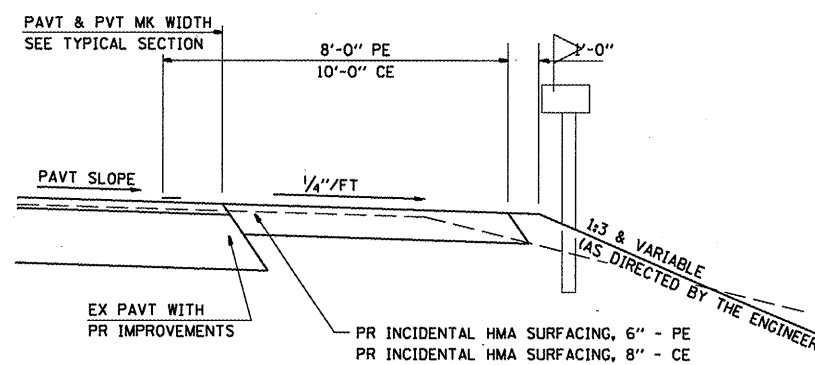

SECTION X-X THRU MAILBOX TURNOUT
 COMBINED WITH EX HMA & PC CONC PE & CE

- NOTE 1 IF MORE THAN ONE MAILBOX IS PRESENT, DIMENSION FROM CENTER OF END MAILBOX.
- NOTE 2 FOR ENTRANCE LAYOUT DIMENSIONS AND SECTIONS A-A & E-E REFER TO THE SCHEDULES IN THE PLANS.
- NOTE 3 BOTH LT OR RT OFFSETS FOR MAILBOX SHOWN USE OFFSET DIMENSION PER SCHEDULE AND REFER TO LAYOUT SHOWN ON THE PLAN.

ALL DIMENSIONS ARE IN INCHES
 UNLESS OTHERWISE SHOWN.

FILE NAME =	USER NAME = coxjw	DESIGNED -	REVISED -	STATE OF ILLINOIS DEPARTMENT OF TRANSPORTATION	DETAILS FOR RURAL ENTRANCE, MAILBOX TURNOUT & SIDE ROAD	F.A.P. RTE.	SECTION	COUNTY	TOTAL SHEETS	SHEET NO.
ca\pwwork\PMIDOT\COXJW\dms22861\Shed	oils.dgn	DRAWN -	REVISED -			777	IORS-5	Montgomery	54	51
	PLOT SCALE = 106.0000' / IN.	CHECKED -	REVISED -							
	PLOT DATE = Aug-13-2009 10:36:05AM	DATE = 7/1/09	REVISED -							
						SCALE:	SHEET NO. 2 OF 5 SHEETS	STA.	TO STA.	CONTRACT NO. 72A68
						ILLINOIS FED. AID PROJECT				